

SBC CHAIN & PINION SLIDE GATE VALVE

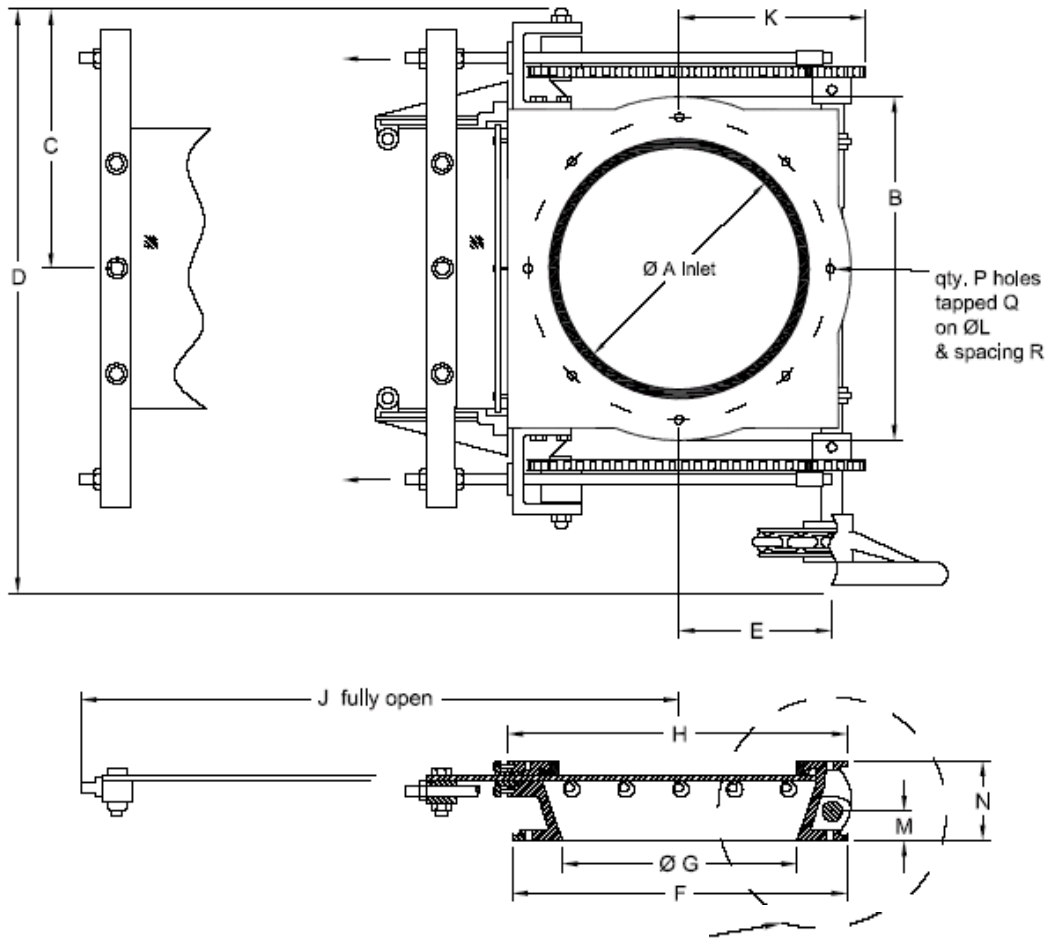

SB15 - SB35C -- 240mm dia. Handwheel or 160mm dia. Chainwheel
 SB40C -- 300mm dia. Handwheel

Dimensions are approximate and subject to change without notice

Valve Size	A	B	C	D	E	F	G	H	J	K	L	M	N	P	Q	R	Weight KG
SB15C	150	270	225	515	106	270	150	270	360	148	230	33	89	8	M10	45° on centre	16
SB20C	200	320	250	565	132	320	200	320	435	173	280	33	89	8	M10	45° on centre	18
SB25C	250	370	275	615	156	370	250	370	510	198	330	33	89	8	M10	45° on centre	24
SB30C	300	420	300	665	181	420	300	420	585	223	380	33	89	8	M10	45° on centre	23
SB35C	355	533	328	728	230	533	355	533	755	260	476	38	102	12	M12	30° off centre	45
SB40C	405	597	385	815	250	597	405	597	860	300	540	38	102	16	M12	22.5° off centre	60

Weights are for aluminium – iron & stainless steel are approximately 2X weights shown

BUSH & WILTON LTD

6, Millennium Place
 Tiverton Business Park
 Tiverton
 Devon EX16 6SB

Tel: + 44 (0) 1884 242233 Fax: + 44 (0) 1884 252555
sales@bushandwilton.com <http://www.bushandwilton.com>