



**POMPE
AD INGRANAGGI
GEAR PUMPS**



CATALOGO
TECNICO
TECHNICAL
CATALOGUE

CARATTERISTICHE GENERALI

MAIN FEATURES

Il presente catalogo include pompe ad ingranaggi esterni del Gr. 1, Gr. 2 e del Gr. 3 sia in configurazione singola che in tandem (pompa multipla). Sono dotate di flange e coperchi in alluminio o in ghisa.

Il bilanciamento idrostatico dei rasamenti (boccole) è del tipo doppia compensazione con ripresa del gioco assiale mediante apposita area predefinita. Lubrificazione interna e compensazione sono proporzionali alla pressione di esercizio.

La precisione e la cura nella costruzione dei particolari consentono l'intercambiabilità delle flange di fissaggio e degli ingranaggi (nell'ambito della stessa cilindrata) permettendo in tal modo maggior flessibilità e minori impegni di magazzino presso il cliente.

Sono disponibili le varie esecuzioni secondo gli standard più diffusi (europeo, tedesco, SAE) e, su richiesta, esiste la possibilità di personalizzazioni del cliente. Tutte le pompe sono predisposte per il traino di una eventuale pompa posteriore mediante un apposito kit di trasformazione fornibile separatamente.

Condizioni e limiti di funzionamento

Fluido consigliato:

olio idraulico a base minerale con elevato indice di viscosità (tenendo conto delle condizioni di funzionamento dell'impianto).

Temperatura consigliata:

20÷60 °C.

Temperatura limite con guarnizioni in NBR:

-15÷80 °C

Temperatura limite con guarnizioni in FPM (Viton):

-10÷110 °C.

Pressione ammessa in aspirazione:

0.7÷3 bar assoluti (10÷44 psi).

Viscosità raccomandata:

15÷92 c.St.

Viscosità limite all'avviamento:

2500 c.St.

Filtraggio per pressioni di esercizio fino a 150 bar (fino a 2175 psi):

26/23 ISO DIS 4406.

Filtraggio per pressioni di esercizio >150 bar (>2175 psi):

23/20 ISO DIS 4406.

The present range includes external gear pumps, Group 1, Group 2 and Group 3, single and tandem construction (multiple pump), with aluminium or cast iron end cap and mounting flange.

Floating bushing, double compensated pressure-balanced design with special area for resetting of the end float clearance.

Internal lubrication and pressure compensation are performed proportionally to the operating pressure of the system. Precision machining and top accuracy of all construction details make use of fixation flanges perfectly interchangeable for models of the same delivery range providing more flexibility and less customers' stocks.

The various construction types are available in compliant versions to the applicable Standards (European, German and SAE). On request, clients may ask for customized versions too.

All pumps are designed for combined operation with an eventual retrofittable rear pump.

Assembly kit for rear-mount is available on request.

Operating conditions

Recommended fluid:

High-viscosity, mineral hydraulic oil (please always pay attention to the operating conditions of the equipment).

Recommended temperature range:

20÷60 °C

Operating temperature range for NBR gaskets:

-15÷80 °C.

Operating temperature range for FPM (Viton) gaskets:

-10÷110 °C.

Admissible suction pressure:

0.7÷3 bar absolute (10÷44 psi absolute).

Recommended viscosity range:

15÷92 c.St.

Max viscosity at start-up:

2500 c.St.

Filtering for operating pressure up to 150 bar (up to 2175 psi):

26/23 ISO DIS 4406.

Filtering for operating pressure >150 bar (>2175 psi):

23/20 ISO DIS 4406.

Note per l'installazione

- Verificare il corretto senso di rotazione della pompa.
- Collegare il condotto di aspirazione al lato della pompa riportante l'apposito riferimento o, in sua assenza, al foro di dimensione maggiore.
- Non sono ammessi carichi assiali e/o radiali sull'albero della pompa: effettuare il collegamento all'albero motore con giunto non rigido, appositamente lubrificato e libero di muoversi assialmente.
- In caso di presenza di carichi sull'albero della pompa, interporre un supporto munito di cuscinetti.
- In caso di verniciatura della pompa proteggere l'anello di tenuta per albero rotante.
- Rimuovere eventuali impurità quali polvere o particelle abrasive dalla zona dell'albero rotante a contatto con l'anello di tenuta.
- Rimuovere trucioli e/o impurità dai fori di connessione e dai piani di appoggio su corpo e flangia di fissaggio.
- Riempire la pompa di fluido facendola ruotare a mano per evitare il primo avviamento a secco
- Agevolare la fuoriuscita dell'aria dall'impianto alla prima accensione allentando momentaneamente il tubo di mandata della pompa.
- Mantenere l'olio pulito a salvaguardia di tutti i componenti dell'impianto, controllando periodicamente lo stato dei filtri.
- Eseguire eventuali rabbocchi con olio idraulico dello stesso tipo.

Important installation tips

- Check for correct pump rotation in the proper direction.
- Connect the suction pipe to the pump side marked by the relevant sign or, failure of any mark, to the largest hole.
- Do not apply any axial/radial loads on the shaft of the pump. Do not use a rigid coupling for connection to the motor shaft, provide for due lubrication and axial clearance of the coupling.
- If a load is to be applied on the shaft of the pump, be sure to install a suitable external bearing for the load.
- Protect the seal of the drive shaft before painting the pump.
- Accurately remove eventual foreign matters (such as dust and abrasive particles) from the shaft area touching the sealing ring.
- Remove chips and/or metal shavings from the connection holes, from the body bearing faces and from the mounting flange.
- As you fill fluid into the pump, be sure to manually let the pump rotate in order to avoid dry start-ups.
- Release the delivery pipe to facilitate bleeding the pump at first startup.
- Be sure to keep running the pump with very clean oil to avoid even major damages to the various parts and components. Perform regular periodic controls of the filters.
- If required, perform oil touch-ups using oil of the same kind.

I dati contenuti nel presente catalogo sono indicativi e possono essere modificati senza alcun preavviso.

The information provided in this catalogue is subject to change without notice.

A technical drawing of a mechanical part, possibly a bracket or a housing, shown in a perspective view. The drawing is rendered in white lines on a yellow background. It features a rectangular base with rounded corners and several circular holes. A cylindrical component is attached to the right side of the base. The drawing is a line art representation, showing the geometry and features of the part.

DATI TECNICI
TECHNICAL DATA

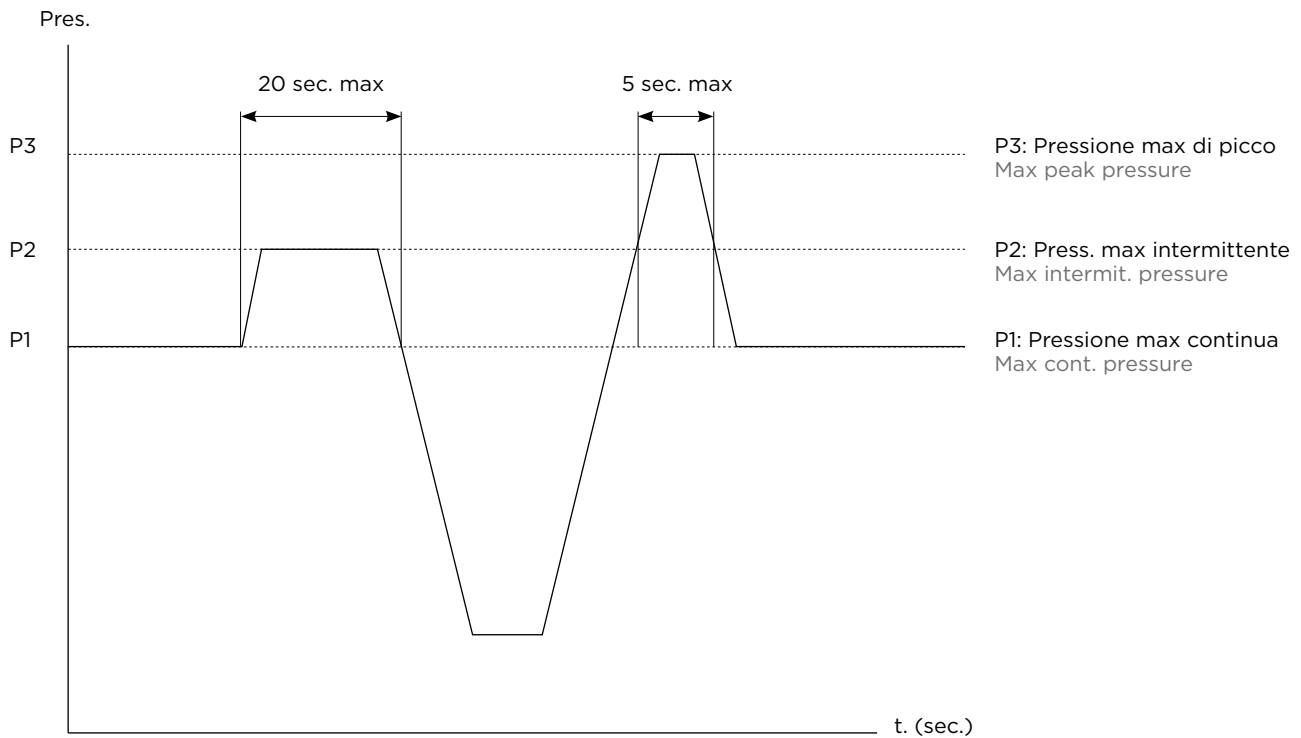

INVERSIONE SENSO DI ROTAZIONE - ROTATION REVERSAL

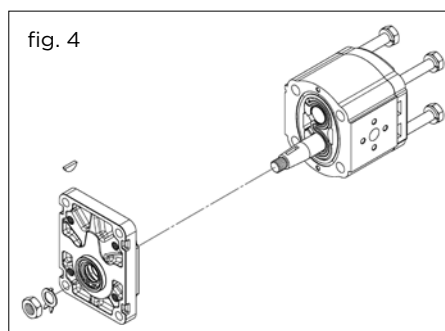
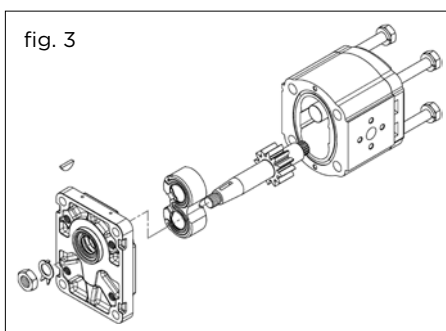
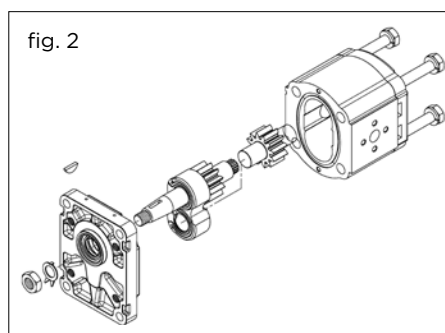
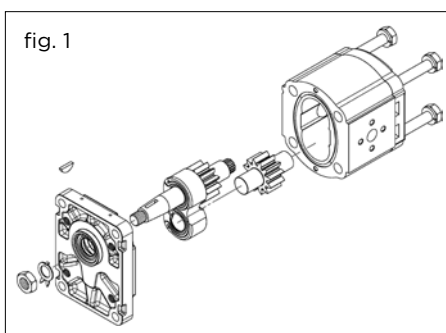

I. Smontare la pompa (fig.1)
Disassemble the pump.

II. Invertire la posizione degli ingranaggi lasciando la boccola con lo stesso orientamento (fig.2 - 3)
Invert gears position leaving the bushing with its previous orientation.

III. Capovolgere la flangia e riassemblare la pompa serrando le viti con coppia $47\text{Nm} \pm 3$ (fig.4)

Reverse the flange and reassemble the pump tightening the screws with torque of $47\text{Nm} \pm 3$.

GRUPPO 2
GROUP 2



CARATTERISTICHE TECNICHE - TECHNICAL CHARACTERISTICS

Grandezza Size	Cilindrata cm ³ /giro Displacement (in ³ /rev)	Velocità max giri/min Max speed rpm	Portata max lt/min Max flow (gpm)	Velocità min giri/min Min speed rpm	Portata min lt/min Min flow (gpm)	Rendim. Vol. min* % Min Volum. Effic.* %
BG20-04	4.2 (0.27)	4000	16.8 (4.44)	500	2.1 (0.55)	93
BG20-06	6.2 (0.38)	4000	24.8 (6.55)	500	3.1 (0.82)	94
BG20-08	8.3 (0.51)	3500	29.0 (7.66)	500	4.2 (1.11)	95
BG20-11	11.1 (0.68)	3500	38.9 (10.28)	500	5.6 (1.48)	95
BG20-14	14.2 (0.87)	3500	49.6 (13.10)	500	7.1 (1.88)	95
BG20-17	16.7 (1.02)	3500	58.5 (15.45)	500	8.4 (2.22)	95
BG20-20	19.6 (1.20)	3300	64.7 (17.09)	500	9.8 (2.59)	95
BG20-23	22.7 (1.39)	2800	63.6 (16.8)	500	11.4 (3.01)	95
BG20-26	26.1 (1.59)	2500	65.2 (17.22)	500	13.0 (3.43)	95

*Rendimento volumetrico a 1500 giri/min * Volumetric efficiency at 1500 rpm



STO
Flangia standard
Standard flange



BZO / BNO
Flangia B50 C
B50 C flange



S20 / S21
Flangia Sae A / SAE A-OR
Sae A / SAE A-OR flange



E21 / EN1
Flangia E52 C
E52 C flange



B80
Flangia B80 C
B80 C flange

BG20 GR.2

FLANGIA STANDARD **STO**
STANDARD FLANGE **STO**

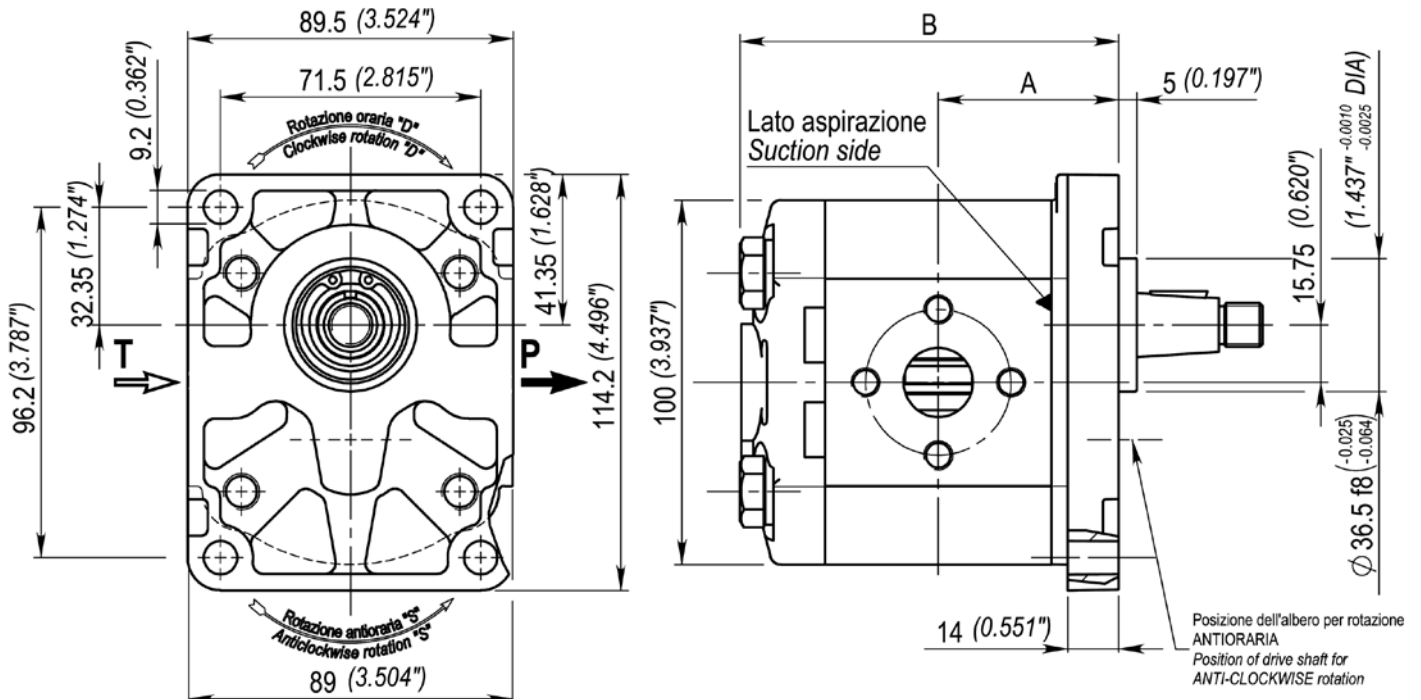

DIMENSIONI E PESI - EXTERNAL DIMENSIONS AND WEIGHTS

Grandezza Size	Cilindrata cm ³ /giro Displacement (in ³ /rev)	Pressione max di esercizio Max working pressure			Dimensioni Dimensions		Massa kg Mass (lbs)
		P1 Bar (psi)	P2 Bar (psi)	P3 Bar (psi)	A mm (in)	B mm (in)	
BG20-04	4.2 (0.27)	250 (3625)	270 (3916)	290 (4206)	43.9 (1.73)	92.6 (3.65)	2.16 (4.76)
BG20-06	6.2 (0.38)	250 (3625)	270 (3916)	290 (4206)	45.5 (1.79)	95.9 (3.78)	2.25 (4.96)
BG20-08	8.3 (0.51)	250 (3625)	270 (3916)	290 (4206)	47.3 (1.86)	99.4 (9.91)	2.27 (5.00)
BG20-11	11.1 (0.68)	250 (3625)	270 (3916)	290 (4206)	49.6 (1.95)	104.1 (4.10)	2.46 (5.42)
BG20-14	14.2 (0.87)	250 (3625)	270 (3916)	290 (4206)	52.2 (2.06)	109.2 (4.30)	2.60 (5.73)
BG20-17	16.7 (1.02)	230 (3336)	240 (3481)	250 (3625)	54.3 (2.14)	113.4 (4.47)	2.72 (6.00)
BG20-20	19.6 (1.20)	210 (3046)	220 (3191)	230 (3336)	56.7 (2.32)	118.2 (4.65)	2.85 (6.28)
BG20-23	22.7 (1.39)	190 (2756)	200 (2901)	210 (3046)	59.3 (2.34)	123.4 (4.86)	2.99 (6.59)
BG20-26	26.1 (1.59)	170 (2466)	180 (2611)	190 (2756)	62.1 (2.45)	129.0 (5.08)	3.15 (6.94)

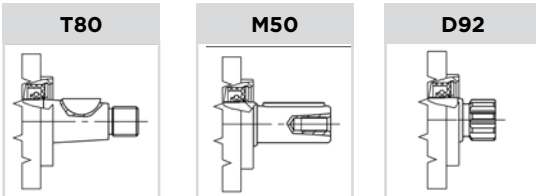
ALBERI CONSIGLIATI - SUGGESTED SHAFTS

Vedi dimensioni a fine sezione BG20
See dimensions at the end of section BG20

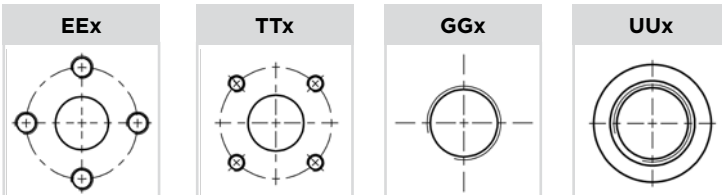
CONNESSIONI DISPONIBILI - SAVALIABLE CONNECTIONS

Vedi dimensioni a fine sezione BG20
See dimensions at the end of section BG20

“X” = numero variabile dipendente dalla cilindrata
“X” = variable number that depends on the displacement

CODICE ORDINAZIONE - ORDERING CODE

BG20	CODICE CODE	
	CILINDRATA DISPLACEMENT	04 06 08 11 14 17 20 23 26 4.2 6.2 8.3 11.1 14.2 16.7 19.6 22.7 26.1
	FLANGIA FLANGE	ST0 Standard Standard
	FLANGIA E COPERCHIO FLANGE AND COVER	A Alluminio Aluminium G Ghisa Cast iron (Heavy duty)
	ALBERO SHAFT	T80 M50 D92
	CONNESSIONE CONNECTION	EEx TTx GGx UUx
	ROTAZIONE ROTATION	D Rotazione destra Clockwise rotation S Rotazione sinistra Anticlockwise rotation
	COPERCHIO STANDARD STANDARD COVER	0 Standard Standard
	GUARNIZIONI SEALS	O Tenute in Nbr Nbr seals V Tenute in Viton® Viton® seals

BG20 GR.2

FLANGIA SAE A **S20** / SAE A-OR **S21**
SAE A **S20** / SAE A-OR **S21** FLANGE

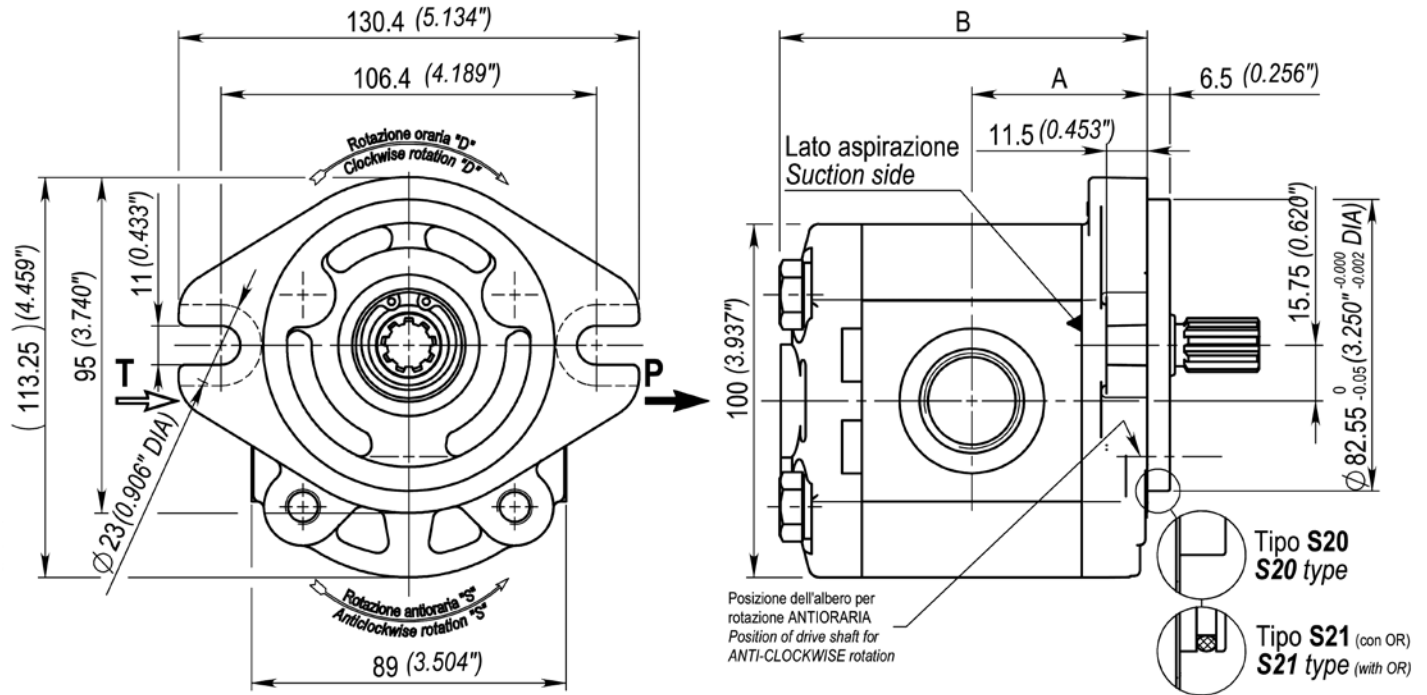

DIMENSIONI E PESI - EXTERNAL DIMENSIONS AND WEIGHTS

Grandezza Size	Cilindrata cm ³ /giro Displacement (in ³ /rev)	Pressione max di esercizio Max working pressure			Dimensioni Dimensions		Massa kg Mass (lbs)
		P1 Bar (psi)	P2 Bar (psi)	P3 Bar (psi)	A mm (in)	B mm (in)	
BG20-04	4.2 (0.27)	250 (3625)	270 (3916)	290 (4206)	43.9 (1.73)	92.6 (3.65)	2.18 (4.81)
BG20-06	6.2 (0.38)	250 (3625)	270 (3916)	290 (4206)	45.5 (1.79)	95.9 (3.78)	2.26 (4.98)
BG20-08	8.3 (0.51)	250 (3625)	270 (3916)	290 (4206)	47.3 (1.86)	99.4 (9.91)	2.36 (5.20)
BG20-11	11.1 (0.68)	250 (3625)	270 (3916)	290 (4206)	49.6 (1.95)	104.1 (4.10)	2.48 (5.47)
BG20-14	14.2 (0.87)	250 (3625)	270 (3916)	290 (4206)	52.2 (2.06)	109.2 (4.30)	2.62 (5.78)
BG20-17	16.7 (1.02)	230 (3336)	240 (3481)	250 (3625)	54.3 (2.14)	113.4 (4.47)	2.73 (6.02)
BG20-20	19.6 (1.20)	210 (3046)	220 (3191)	230 (3336)	56.7 (2.32)	118.2 (4.65)	2.87 (6.33)
BG20-23	22.7 (1.39)	190 (2756)	200 (2901)	210 (3046)	59.3 (2.34)	123.4 (4.86)	3.01 (6.64)
BG20-26	26.1 (1.59)	170 (2466)	180 (2611)	190 (2756)	62.1 (2.45)	129.0 (5.08)	3.16 (6.97)

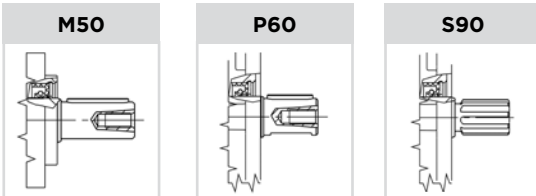
ALBERI CONSIGLIATI - SUGGESTED SHAFTS

Vedi dimensioni a fine sezione BG20
See dimensions at the end of section BG20

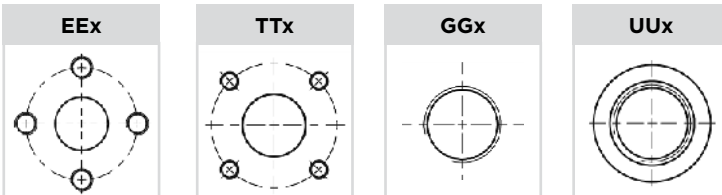
CONNESSIONI DISPONIBILI - SAVALIABLE CONNECTIONS

Vedi dimensioni a fine sezione BG20
See dimensions at the end of section BG20

"X" = numero variabile dipendente dalla cilindrata
"X" = variable number that depends on the displacement

CODICE ORDINAZIONE - ORDERING CODE

BG20	CODICE CODE	
	CILINDRATA DISPLACEMENT	04 06 08 11 14 17 20 23 26 4.2 6.2 8.3 11.1 14.2 16.7 19.6 22.7 26.1
	FLANGIA FLANGE	S20 SAE A SAE A S21 SAE con O-Ring SAE with O-Ring
	FLANGIA E COPERCHIO FLANGE AND COVER	A Alluminio Aluminium G Ghisa Cast iron (Heavy duty)
	ALBERO SHAFT	M50 P60 S90
	CONNESSIONE CONNECTION	EEx TTx GGx UUx
	ROTAZIONE ROTATION	D Rotazione destra Clockwise rotation S Rotazione sinistra Anticlockwise rotation
	COPERCHIO STANDARD STANDARD COVER	0 Standard Standard
	GUARNIZIONI SEALS	O Tenute in Nbr Nbr seals V Tenute in Viton® Viton® seals

BG20 GR.2

FLANGIA B80 C **B80**
B80 C FLANGE **B80**

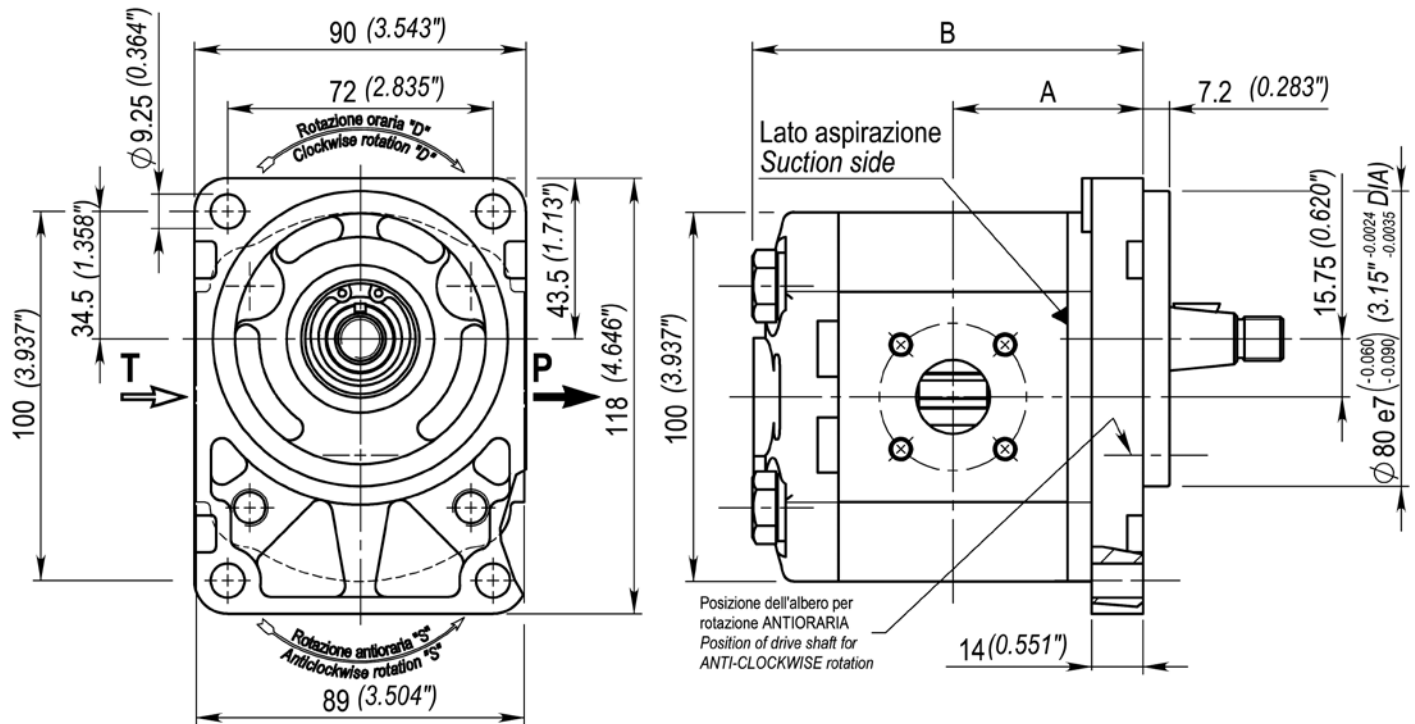

DIMENSIONI E PESI - EXTERNAL DIMENSIONS AND WEIGHTS

Grandezza Size	Cilindrata cm ³ /giro Displacement (in ³ /rev)	Pressione max di esercizio Max working pressure			Dimensioni Dimensions		Massa kg Mass (lbs)
		P1 Bar (psi)	P2 Bar (psi)	P3 Bar (psi)	A mm (in)	B mm (in)	
BG20-04	4.2 (0.27)	250 (3625)	270 (3916)	290 (4206)	45.9 (1.81)	94.6 (3.72)	2.23 (4.92)
BG20-06	6.2 (0.38)	250 (3625)	270 (3916)	290 (4206)	47.5 (1.87)	97.9 (3.85)	2.31 (5.09)
BG20-08	8.3 (0.51)	250 (3625)	270 (3916)	290 (4206)	49.3 (1.94)	101.4 (9.99)	2.41 (5.31)
BG20-11	11.1 (0.68)	250 (3625)	270 (3916)	290 (4206)	51.6 (2.03)	106.1 (4.18)	2.52 (5.56)
BG20-14	14.2 (0.87)	250 (3625)	270 (3916)	290 (4206)	54.2 (2.13)	111.2 (4.38)	2.66 (5.86)
BG20-17	16.7 (1.02)	230 (3336)	240 (3481)	250 (3625)	56.3 (2.22)	115.4 (4.54)	2.79 (6.15)
BG20-20	19.6 (1.20)	210 (3046)	220 (3191)	230 (3336)	58.7 (2.31)	120.2 (4.73)	2.92 (6.44)
BG20-23	22.7 (1.39)	190 (2756)	200 (2901)	210 (3046)	61.3 (2.41)	125.4 (4.94)	3.07 (6.77)
BG20-26	26.1 (1.59)	170 (2466)	180 (2611)	190 (2756)	64.1 (2.52)	131.0 (5.16)	3.21 (7.08)

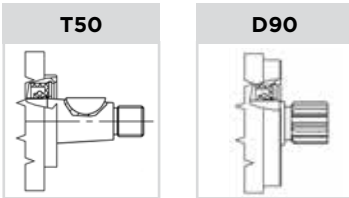
ALBERI CONSIGLIATI - SUGGESTED SHAFTS

Vedi dimensioni a fine sezione BG20
See dimensions at the end of section BG20

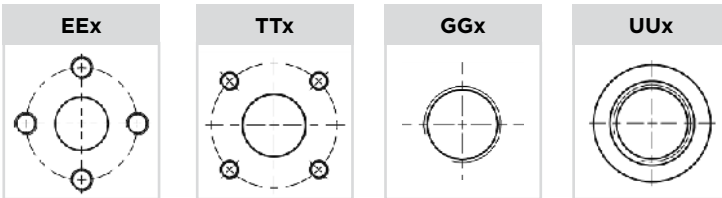
CONNESSIONI DISPONIBILI - SAVALIABLE CONNECTIONS

Vedi dimensioni a fine sezione BG20
See dimensions at the end of section BG20

"X" = numero variabile dipendente dalla cilindrata
"X" = variable number that depends on the displacement

CODICE ORDINAZIONE - ORDERING CODE

BG20	CODICE CODE	
	CILINDRATA DISPLACEMENT	04 06 08 11 14 17 20 23 26 4.2 6.2 8.3 11.1 14.2 16.7 19.6 22.7 26.1
	FLANGIA FLANGE	B80 Flangia B80 C B80 C Flange
	FLANGIA E COPERCHIO FLANGE AND COVER	A Alluminio Aluminium
	ALBERO SHAFT	T50 D90
	CONNESSIONE CONNECTION	EEx TTx GGx UUX
	ROTAZIONE ROTATION	D Rotazione destra Clockwise rotation S Rotazione sinistra Anticlockwise rotation
	COPERCHIO STANDARD STANDARD COVER	0 Standard Standard
	GUARNIZIONI SEALS	O Tenute in Nbr Nbr seals V Tenute in Viton® Viton® seals

BG20 GR.2

FLANGIA B50 C **BZO** / **BN0**
B50 C FLANGE **BZO** / **BN0**

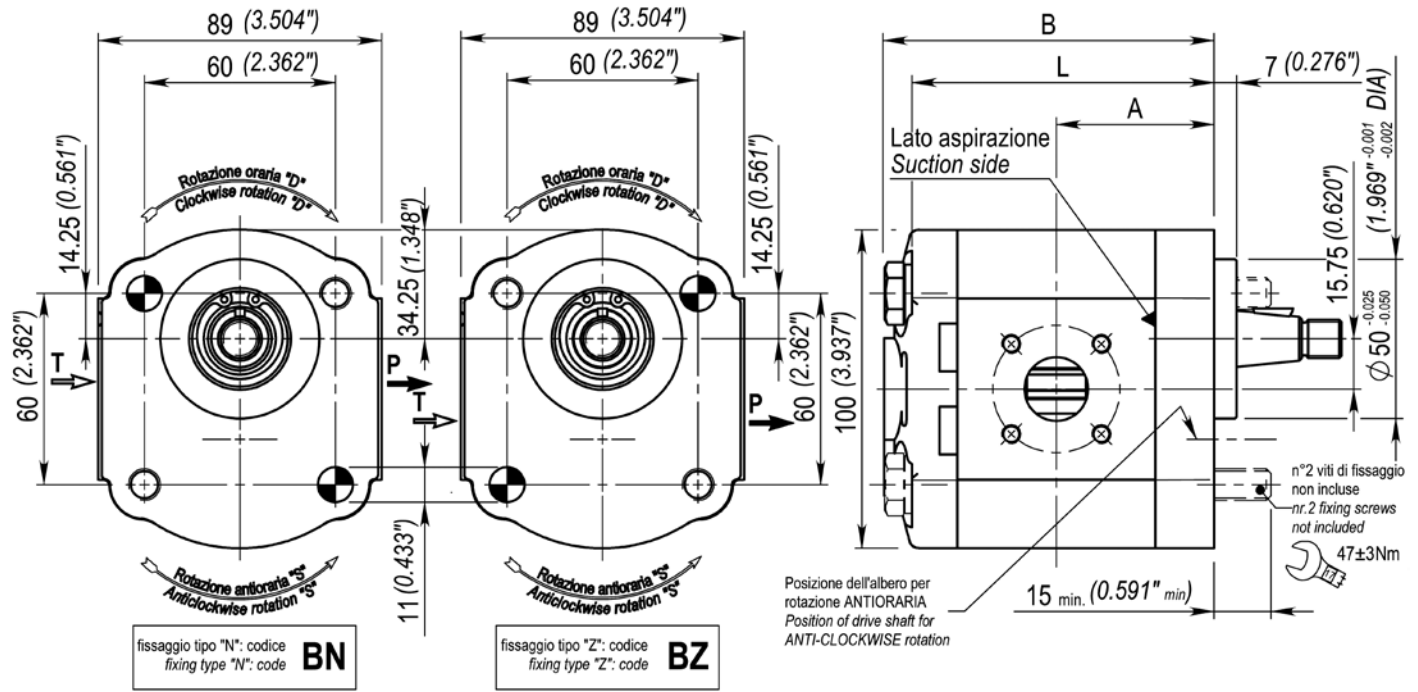

DIMENSIONI E PESI - EXTERNAL DIMENSIONS AND WEIGHTS

Grandezza Size	Cilindrata cm ³ /giro Displacement (in ³ /rev)	Pressione max di esercizio Max working pressure			Dimensioni Dimensions			Massa* kg Mass* (lbs)
		P1 Bar (psi)	P2 Bar (psi)	P3 Bar (psi)	A mm (in)	B mm (in)	L mm (in)	
BG20-04	4.2 (0.27)	250 (3625)	270 (3916)	290 (4206)	43.9 (1.73)	92.6 (3.65)	83.5 (3.29)	2.00 (4.41)
BG20-06	6.2 (0.38)	250 (3625)	270 (3916)	290 (4206)	45.5 (1.79)	95.9 (3.78)	86.8 (3.42)	2.09 (4.61)
BG20-08	8.3 (0.51)	250 (3625)	270 (3916)	290 (4206)	47.3 (1.86)	99.4 (9.91)	90.3 (3.56)	2.18 (4.81)
BG20-11	11.1 (0.68)	250 (3625)	270 (3916)	290 (4206)	49.6 (1.95)	104.1 (4.10)	95.0 (3.74)	2.30 (5.07)
BG20-14	14.2 (0.87)	250 (3625)	270 (3916)	290 (4206)	52.2 (2.06)	109.2 (4.30)	100.1 (3.94)	2.43 (5.36)
BG20-17	16.7 (1.02)	230 (3336)	240 (3481)	250 (3625)	54.3 (2.14)	113.4 (4.47)	104.3 (4.106)	2.54 (5.60)
BG20-20	19.6 (1.20)	210 (3046)	220 (3191)	230 (3336)	56.7 (2.32)	118.2 (4.65)	109.1 (4.30)	2.67 (5.89)
BG20-23	22.7 (1.39)	190 (2756)	200 (2901)	210 (3046)	59.3 (2.34)	123.4 (4.86)	114.3 (4.50)	2.80 (6.17)
BG20-26	26.1 (1.59)	170 (2466)	180 (2611)	190 (2756)	62.1 (2.45)	129.0 (5.08)	119.9 (4.72)	2.95 (6.50)

* Massa senza viti di fissaggio * Mass without fixing screws

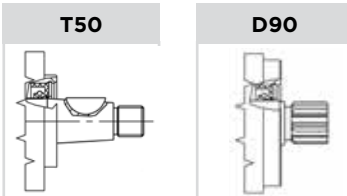
ALBERI CONSIGLIATI - SUGGESTED SHAFTS

Vedi dimensioni a fine sezione BG20
See dimensions at the end of section BG20

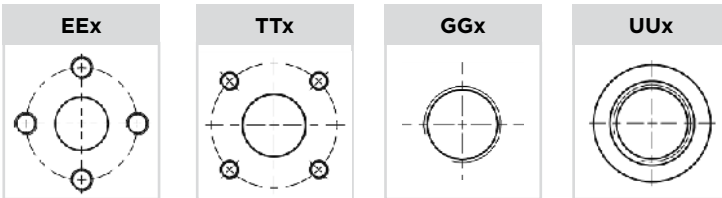
CONNESSIONI DISPONIBILI - SAVALIABLE CONNECTIONS

Vedi dimensioni a fine sezione BG20
See dimensions at the end of section BG20

“X” = numero variabile dipendente dalla cilindrata
“X” = variable number that depends on the displacement

CODICE ORDINAZIONE - ORDERING CODE

BG20	CODICE CODE	
	CILINDRATA DISPLACEMENT	04 06 08 11 14 17 20 23 26 4.2 6.2 8.3 11.1 14.2 16.7 19.6 22.7 26.1
	FLANGIA FLANGE	BZ0 B50 C fissaggio “Z” B50 C “Z” assembly BNO B50 C fissaggio “N” B50 C “N” assembly
	FLANGIA E COPERCHIO FLANGE AND COVER	A Alluminio Aluminium
	ALBERO SHAFT	T50 D90
	CONNESSIONE CONNECTION	EEx TTx GGx UUx
	ROTAZIONE ROTATION	D Rotazione destra Clockwise rotation S Rotazione sinistra Anticlockwise rotation
	COPERCHIO STANDARD STANDARD COVER	0 Standard Standard
	GUARNIZIONI SEALS	O Tenute in Nbr Nbr seals V Tenute in Viton® Viton® seals

BG20 GR.2

FLANGIA E52 C **EZ1 / EN1**
E52 C FLANGE **EZ1 / EN1**

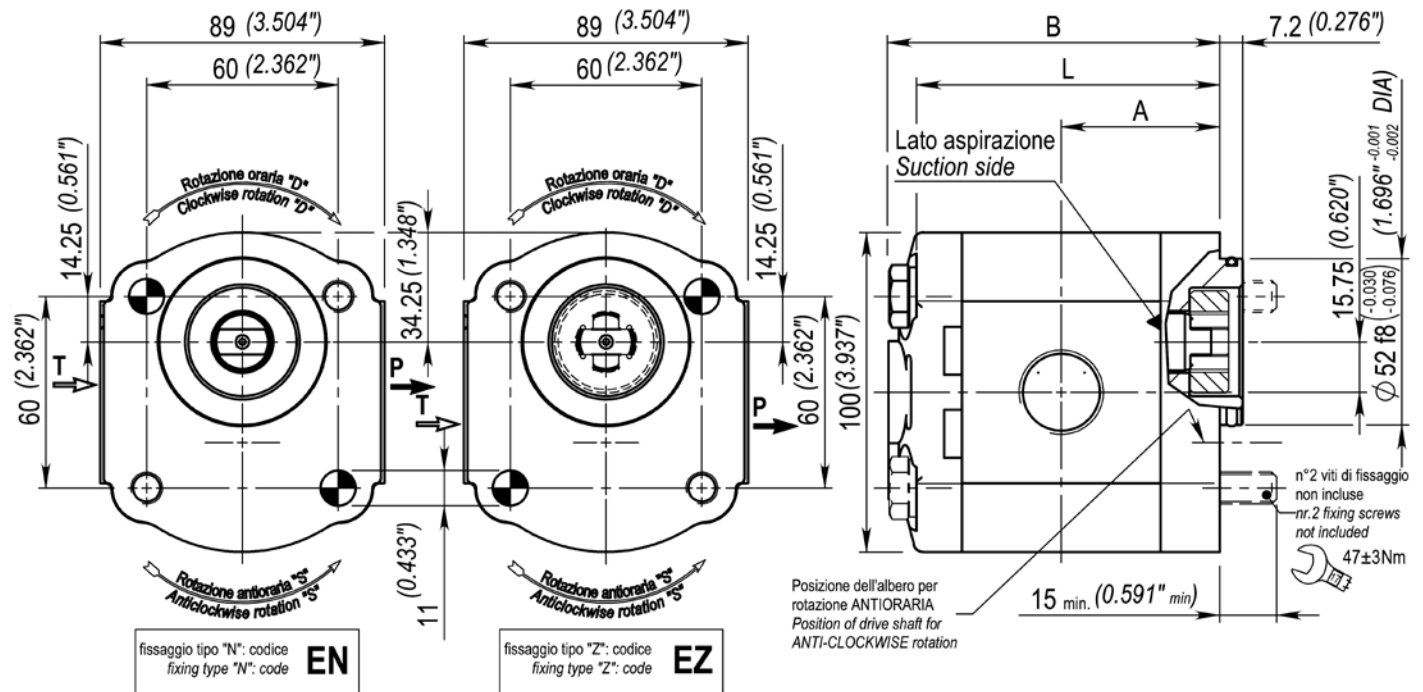

DIMENSIONI E PESI - EXTERNAL DIMENSIONS AND WEIGHTS

Grandezza Size	Cilindrata cm ³ /giro Displacement (in ³ /rev)	Pressione max di esercizio Max working pressure			Dimensioni Dimensions			Massa* kg Mass* (lbs)
		P1 Bar (psi)	P2 Bar (psi)	P3 Bar (psi)	A mm (in)	B mm (in)	L mm (in)	
BG20-04	4.2 (0.27)	250 (3625)	270 (3916)	290 (4206)	43.9 (1.73)	92.6 (3.65)	83.5 (3.29)	1.91 (4.21)
BG20-06	6.2 (0.38)	250 (3625)	270 (3916)	290 (4206)	45.5 (1.79)	95.9 (3.78)	86.8 (3.42)	1.99 (4.39)
BG20-08	8.3 (0.51)	250 (3625)	270 (3916)	290 (4206)	47.3 (1.86)	99.4 (9.91)	90.3 (3.56)	2.08 (4.59)
BG20-11	11.1 (0.68)	250 (3625)	270 (3916)	290 (4206)	49.6 (1.95)	104.1 (4.10)	95.0 (3.74)	2.20 (4.85)
BG20-14	14.2 (0.87)	250 (3625)	270 (3916)	290 (4206)	52.2 (2.06)	109.2 (4.30)	100.1 (3.94)	2.33 (5.14)
BG20-17	16.7 (1.02)	230 (3336)	240 (3481)	250 (3625)	54.3 (2.14)	113.4 (4.47)	104.3 (4.106)	2.44 (5.38)
BG20-20	19.6 (1.20)	210 (3046)	220 (3191)	230 (3336)	56.7 (2.32)	118.2 (4.65)	109.1 (4.30)	2.57 (5.67)
BG20-23	22.7 (1.39)	190 (2756)	200 (2901)	210 (3046)	59.3 (2.34)	123.4 (4.86)	114.3 (4.50)	2.71 (5.97)
BG20-26	26.1 (1.59)	170 (2466)	180 (2611)	190 (2756)	62.1 (2.45)	129.0 (5.08)	119.9 (4.72)	2.85 (6.28)

* Massa senza viti di fissaggio e giunto * Mass without fixing screws and joint

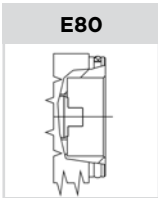
ALBERI CONSIGLIATI - SUGGESTED SHAFTS

Vedi dimensioni a fine sezione BG20
See dimensions at the end of section BG20

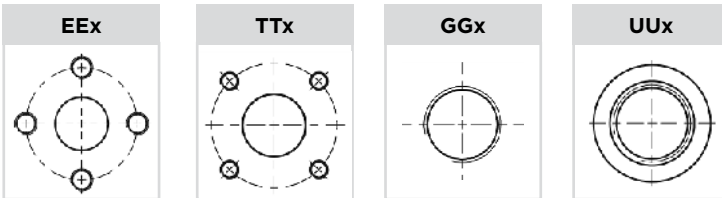
CONNESSIONI DISPONIBILI - SAVALIABLE CONNECTIONS

Vedi dimensioni a fine sezione BG20
See dimensions at the end of section BG20

“X” = numero variabile dipendente dalla cilindrata
“X” = variable number that depends on the displacement

CODICE ORDINAZIONE - ORDERING CODE

BG20	CODICE CODE	
	CILINDRATA DISPLACEMENT	04 06 08 11 14 17 20 23 26 4.2 6.2 8.3 11.1 14.2 16.7 19.6 22.7 26.1
	FLANGIA FLANGE	EZ1 E52 C FISSAGGIO “Z” E52 C “Z” ASSEMBLY EN1 E52C C FISSAGGIO “N” E52 C “N” ASSEMBLY
	FLANGIA E COPERCHIO FLANGE AND COVER	A Alluminio Aluminium
	ALBERO SHAFT	E80
	CONNESSIONE CONNECTION	EEx TTx GGx UUX
	ROTAZIONE ROTATION	D Rotazione destra Clockwise rotation S Rotazione sinistra Anticlockwise rotation
	COPERCHIO STANDARD STANDARD COVER	0 Standard Standard
	GUARNIZIONI SEALS	0 Tenute in Nbr Nbr seals V Tenute in Viton® Viton® seals
	ACCESSORI OPTIONALS	3 Con giunto With coupling

T80

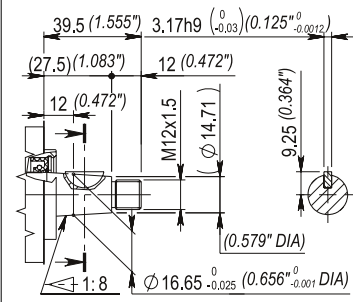

CONICITÀ 1:8
TAPER 1:8

Coppia max trasmissibile 135 Nm
Max torque 135 Nm

T50

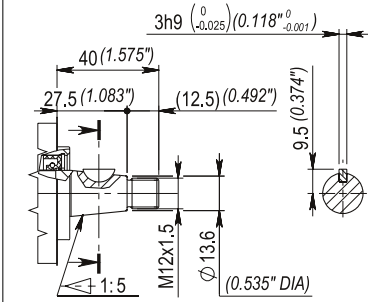

CONICITÀ 1:5
TAPER 1:5

Coppia max trasmissibile 140 Nm
Max torque 140 Nm

D90

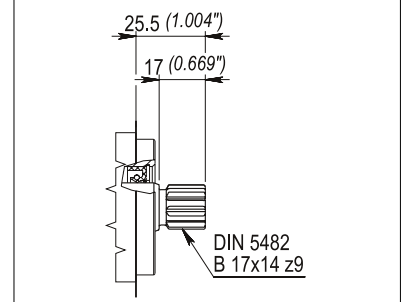

DIN Z9 FLANGIA TEDESCA
DIN Z9 GERMAN FLANGE

Coppia max trasmissibile 110 Nm
Max torque 110 Nm

M50

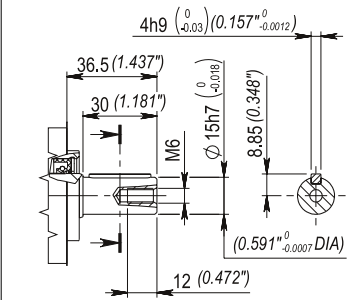

CILINDRICO
CYLINDRICAL

Coppia max trasmissibile 90 Nm
Max torque 90 Nm

D92

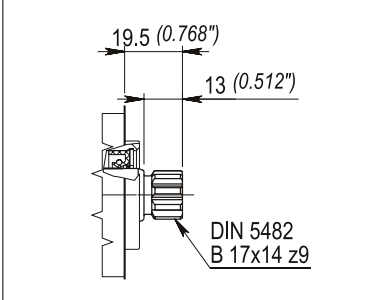

DIN Z9 FLANGIA STANDARD
DIN Z9 STANDARD FLANGE

Coppia max trasmissibile 110 Nm
Max torque 110 Nm

E80

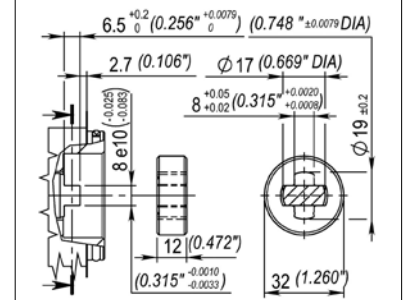

PENNA PER ELETTROPOMPA
TANG DRIVE FOR ELECTRIC MOTOR

Coppia max trasmissibile 70 Nm
Max torque 70 Nm

P60

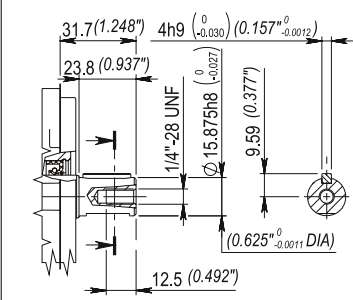

CILINDRICO SAE
SAE CYLINDRICAL

Coppia max trasmissibile 85 Nm
Max torque 85 Nm

S90

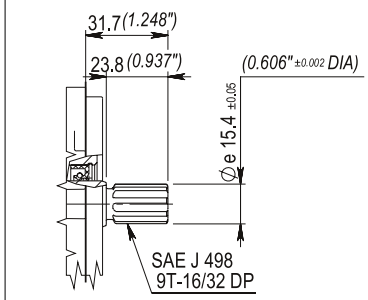

SCANALATO SAE 9 DENTI
SAE SPLINED 9 TEETH

Coppia max trasmissibile 85 Nm
Max torque 85 Nm

Nel caso di montaggio con flangia B80 C (cod B80) le sporgenze vanno ridotte di 2 mm (0.079 in.)
When assembled with B80 C flange (B80 code) the shaft dimensions must be reduced by 0.079 in. (2 mm)

ASPIRAZIONE lato riferimento
SUCTION reference side

MANDATA
DELIVERY

STANDARD EUROPEO - EUROPEAN STANDARD

Grandezza Size	Codice Code	D	F	M	e
04-08	EE4	30 (1.18)	13 (0.51)	M6	13 (0.51)
11-26	EE5	40 (1.58)	19 (0.75)	M8	15 (0.59)

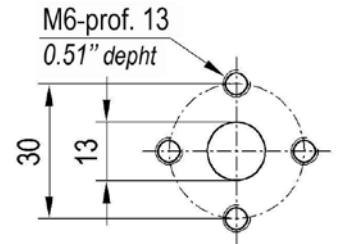
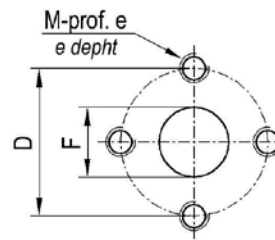

STANDARD EUROPEO PER MOTORI
EUROPEAN STANDARD FOR MOTORS

Grandezza Size	Codice Code
04-08	/
11-26	EE6

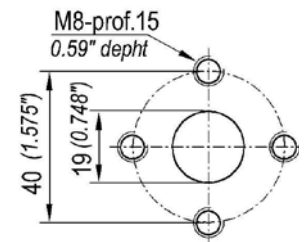
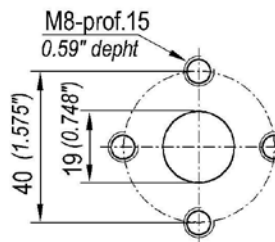

UNIFICAZIONE TEDESCA - GERMAN UNIFICATION

Grandezza Size	Codice Code	D	F
04-08	TT4	35 (1.38)	15 (0.59)
11-26	TT5	40 (1.58)	20 (0.79)

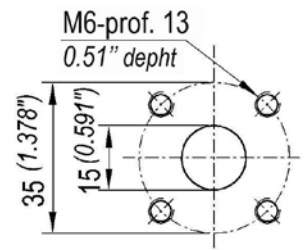
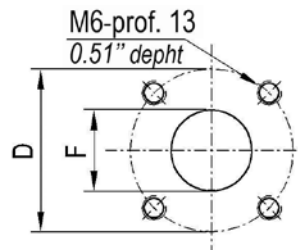

FILETTATURE BSPP - BSPP THREADS

Grandezza Size	Codice Code	BSPP
04-08	GG4	1/2" BSPP
11-26	GG5	3/4" BSPP

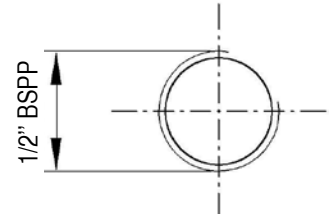
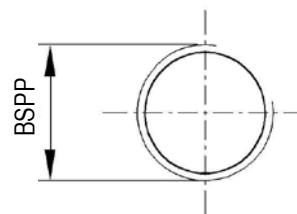

FILETTATURE SAE - SAE THREADS

Grandezza Size	Codice Code	U
04-08	UU4	7/8"-14 UNF
11-26	UU6	1-1/16"-12 UNF

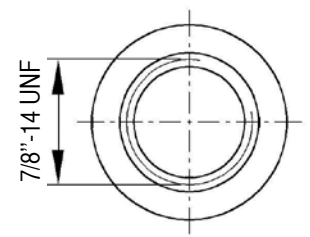
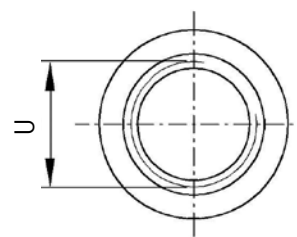



B & C S.r.l
Via Panizzi, 3 - 42011 Bagnolo in Piano (RE), Italy
Tel. +39 0522 951353 - Fax +39 0522 952737
info@bcit.it - www.bcit.it



COMPANY WITH
QUALITY SYSTEM
CERTIFIED BY DNV GL
= ISO 9001 =



www.bcit.it