

**INSTALLATION AND SERVICING INSTRUCTIONS FOR:**  
**STRAXGAS THEME 18 WITH TURBOFLUE**  
**STRAXGAS THEME 22 WITH TURBOFLUE**  
 (To be left with the appliance)

**Appliance data:**

Model	Theme 18		Theme 22	
Country of destination	: United Kingdom & Republic of Ireland		United Kingdom & Republic of Ireland	
Type of gas	: Natural gas (G20) Cat. I <sub>2H</sub> Propane gas (G31) Cat. I <sub>3P</sub>		Natural gas (G20) Cat. I <sub>2H</sub> Propane gas (G31)	
Cat. I <sub>3P</sub>				
Injector size	: 7 x 0.89 multihole	7 x 0.56 multihole	7 x 0.80 multihole (2 off)	7 x 0.62 multihole
Injector marking	: 89	56	80	62
Gross heat input (high setting)	: 7.6kW (26,000Btu/h)	7.6kW (23,000Btu/h)	10.2kW (34,800Btu/h)	10.2kW (34,800Btu/h)
Gross heat input (low setting)	: 4.4kW (15,000Btu/h)	4.4kW (15,000Btu/h)	4.4kW (15,000Btu/h)	4.4kW (15,000Btu/h)
Supply pressure	: 20mbar (8in.w.g.)	37mbar (14in.w.g.)	20mbar (8in.w.g.)	37mbar (14in.w.g.)
Appliance test point press (cold)	: 19.0mbar (± 1.0mbar)	36.5mbar	19.0mbar (± 1.0mbar)	36.5mbar
Minimum wall thickness	: 100mm (4in.)		100mm (4in.)	
Maximum wall thickness	: 500mm (20in.)		500mm (20in.)	
Maximum duct length *	: 9.0metres with 2x90° bends		9.0metres with 2x90° bends	
Ignition	: Electronic		Electronic	
Spark gap	: 3.0mm min., 4.5mm max.		3.0mm min., 4.5mm max.	
Electrical supply	: 230V~ 50Hz 70W		230v~ 50Hz 70W	
Dimensions:	: <b>Theme 18</b>		<b>Theme 22</b>	
Width over frame excluding trim	: 515mm		624mm	
Height over frame excluding trim	: 585mm		585mm	
Depth	: 180mm		223mm	

\* For this installation an optional kit is available. See supplementary instructions for ducted installations.

**Note: The Natural Gas and Propane versions of this appliance are different models and cannot be converted from one gas to another.**

This appliance has been assessed by a Government appointed Notified Body and shown to meet the 'Essential Requirements' of the European Gas Appliance Directive.

The Directive lays down requirements for the safety of the appliance, together with its design, construction, and use of materials. It also requires the production process to be covered by an approved and monitored system of quality assurance.

## Mandatory requirements

The appliance must be installed with due regard to the following **mandatory** regulations:

The relevant British Standard installation specifications and codes of practice, and Building Regulations issued by the Department of the Environment, and Building Standards (Scotland) Consolidated Regulations issued by the Scottish Development Board.

The electrical equipment (safety regulations)

Current IEE Wiring Regulations

Current Gas Safety (Installation and Use) Regulations.

**Failure to install this appliance correctly could lead to prosecution and render the guarantee invalid.**

Attention is drawn to the latest edition of the following standards:

BS3456, Part 101

BS5440, Part 1 Specification for installation of flues.

BS5440, Part 2 Specification for installation of ventilation for gas appliances.

BS5871, Part 2 Installation of decorative fuel effect gas appliances.

BS6891 Specification of low pressure gas pipework

S8303 Replacing CP403.

Institute of Gas Engineers document IGF/UP17 for installation in timber framed buildings.

This Straxgas appliance is an inset live fuel effect gas fire and must only be installed by a competent person (e.g. a C.O.R.G.I. member) in accordance with these installation instructions.

This appliance must be installed in accordance with the rules in force. Consult these instructions before installation and use of this appliance.

**GB** An airbrick or similar fresh air inlet must be fitted in the room which the fire is installed and must have an area not less than 18sq. cm (2.8sq. in). This fresh air inlet must not be blocked or restricted in any way.

**IE & Northern Ireland** Ventilation must be provided in accordance with the rules in force.

## Description

The Theme fire with Turboflue is a live fuel effect gas fire incorporating an integral fan assisted flue system designed for use in locations which do not have a conventional chimney or flue. Products of combustion are extracted from the fire via a duct passing through the wall to the fan unit. A pressure switch detects the flue flow and will only allow the gas to be supplied to the fire when the flue flow is correct.

The Theme fire and Turboflue are controlled by a unique low voltage electronic switch plate designed to be sited adjacent to the fire at a convenient level to avoid any stooping or bending. In most types of installation a false chimney breast will need to be constructed after installation of the appliance. A fire surround can then be fitted if required, and must be a minimum of Class O (100°C temperature rating). Refer to manufacturer's instructions for rebate to determine the depth of the false chimneybreast.

The fire can be fitted to a combustible wall but a minimum gap of 50mm must be provided between the back of the appliance and the rear wall.

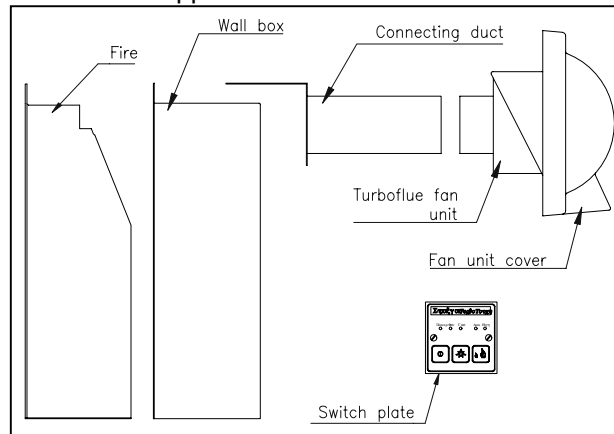

Fig. 1 The Components of the System

## Preparation

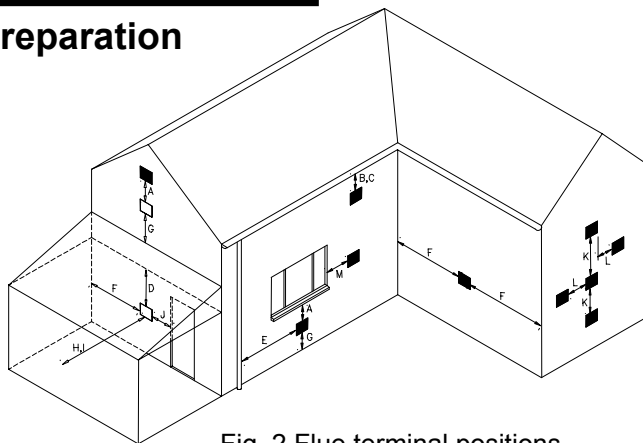

Fig. 2 Flue terminal positions

	TERMINAL POSITION	MIN. DISTANCE
A	Directly below an openable window or other opening e.g. air brick	300mm
B	Below gutters, soil pipes or drain pipes	75mm
C	Below eaves	200mm
D	Below balconies or car port roof	200mm
E	From vertical drain pipes and soil pipes	75mm
F	From internal or external corners	300mm
G	Above ground, roof or balcony level	300mm
H	From a surface facing a terminal	600mm
I	From a terminal facing a terminal	1200mm
J	From an opening in the car port (e.g. door, window) into dwelling	1200mm
K	Vertically from a terminal on the same wall	1500mm
L	Horizontally from a terminal on the same wall	300mm
M	Horizontally from a window or door	300mm

### Before installation

1. Ensure that the local distribution conditions (identification of the type of gas and pressure, and electrical supply) and the adjustment of the appliance are compatible. Refer to burner data badge plate.
2. The fan unit outlet must be positioned such that the combustion products can disperse freely at all times. (See Fig. 2)
3. Due consideration must be given to environmental conditions and sound assessment of the location of the fan unit outlet is essential to prevent nuisance shutdown due to adverse weather or site conditions.

4. If the fan unit outlet is less than 2 metres above the ground and accessible to people, a terminal guard must be fitted (Part no. TG1808).
5. Do not fit a Turboflue where there is a fan driven warm air central heating system without consulting our technical department.
6. The fan unit must be located on an external wall accessible for maintenance.
7. This appliance is not suitable for installation in a room containing a bath or shower.

#### **Additional notes for car ports and other single storey 'add-on' extensions**

1. Any carport or other add-on extension should consist of a roof, or a roof and one other wall. If it consists of a roof and two other walls, the installation shall be treated as suspect and further advice sought.
2. If there is any opening in the carport into the dwelling, e.g. door, window, etc., then the terminal must be at least 1200mm away from that opening. If it is less then the installation must be treated as suspect and further advice sought. If it is more than 1200mm then D, F, H and I shall also apply where D is the vertical distance between the lowest point of the roof and the top of the terminal.
3. If the roof is plastic then the installation should be treated with great care as there is no simple way of protecting the roof.

#### **Clearances**

Soft furnishings, decorations and some wall coverings may discolour or scorch if positioned too close to the fire.

If a shelf is to be fitted above the fire, perhaps as part of a surround, it must be positioned a minimum of 1m (39in.) above the top of the hearth, and project no more than 200mm (8in.) from the front plane of the opening. Combustible material such as wood may be fitted to within 100mm (4in.) of either side of the opening so long as it projects no more than 100mm (4in.) from the front plane of the opening.

#### **Items supplied**

The following items will be found within the fire carton:

1. Convection box and wall box.
2. Separate flat trim, optional canopy trim, or spacer frame with box trim depending on options ordered.
3. Optional fret with brass finials and hinged dummy ashpan cover complete with brass ring.
4. **18" fire:**
  - 2 shaped ceramic fibre blocks
  - 2 piece front coals
  - 8 large and 4 small coals
- 22" fire:**
  - 3 shaped ceramic blocks
  - 3 piece front coals
  - 14 large coals and 2 small coals
5. Screws and wall plugs to complete the installation.
6. These installation instructions, guarantee card and end user operating instructions.

The following items will be found within the Turboflue carton:

1. Fan unit with wall plate, pre-wired with connecting cables.
2. Burner unit.
3. Connecting duct
4. Galvanised wire to form moisture drip collar.
5. Switch plate and plaster depth box.
6. Fasteners.
7. Plastic cable conduit.
8. Insulating slab.

**Warning:** Only Straxgas approved ceramic blocks and coals, designed for this appliance, must be used with this burner. Use of ceramic components from any other supplier will invalidate the guarantee and may be dangerous.

When unpacking the appliance, avoid touching the visible, painted parts as the paint requires curing (this will take approximately 2 hours under fire. In some cases there may be a slight odour given off for a short period).

#### **Fret options**

The following Straxgas frets are suitable for use with this appliance:

- *Black Broughton Classic*
- *Silver Classic*

- Brass finger
- Black finger
- Delta

NO OTHER FRONTS SHOULD BE USED WITH THIS APPLIANCE

---

## Installation

### Site preparation

The appliance must be installed on a level, non-combustible base of dimensions 180mm deep x 450mm wide x 50mm high for the Theme 18, or 240mm deep x 560mm wide x 50mm high for the Theme 22. (Note that the base must be the same height as the hearth). A separate non-combustible hearth in accordance with BS5871, Part 2 must be provided with minimum dimensions as shown in Figs.3 and 4. See also approved document J 1/2/3 "Heat Producing Appliances" issued by the Department of the Environment.

If a suspended timber floor is being used, check that the joists are capable of supporting any structure that may be used.

If a combustible skirting board is fitted, cut away to give a 75mm minimum clearance either side of the convector box or minimum width of hearth where applicable.

The distance from the surface of any part of the appliance to any combustible material must be a minimum of 75mm with an air gap, or 25mm with insulation.

Clear the working area of all debris before removing the Straxgas appliance from the packaging.

**Note:** During building work the cavity in any wall must not be bridged other than by the ducts provided. Ensure that there is no structural damage or damage to the damp course.

### Gas connection

Gas connection shall be with rigid or semi-rigid pipe, by concealed connection only. A 15mm gas supply pipe with isolation cock should be brought to within 1M of the fireplace opening. The 8mm pipe should be brought through the left hand or rear pre-punched hole in the convection box to the burner. (Left hand only with a slim profile installation).

*When passing the pipe through brickwork or plaster, cap the end to prevent entry of debris.*

### Electrical connection

A 230V 50Hz supply via a switched fused spur with at least 3mm contact separation between all poles, and fitted with a 3A fuse is required.

Three pre-wired cables pass through the wall from the fan unit to the burner, supply, and switch plate. The switch plate may be placed at any convenient position within 2 metres of the appliance. (This cable may be supplied as an optional extra up to 15 metres long).

### Position of appliance

Determine that the location of the appliance and fan flue outlet position is suitable. Check that the material of the surround or structure is suitable.

### Installation of wall components

*This section describes the cutting of apertures in the wall, and the fitting of the cable conduit.*

#### 1. Installation in front of an inner wall (Fig. 3)

1. Mark out on the inside wall the centreline of the duct and the 20mm dia. holes.
2. Drill right through the inner and outer walls on the centre line of the duct using a pilot drill, taking care to keep the drill square to the wall. This pilot hole will be used later to align a template on the outer wall.
3. Open out the hole in the inner wall to 150mm dia.
4. Drill the inner wall 20mm dia. for the plastic conduit.

#### 2. Slim profile "cavity" installation (Fig. 4)

The fire can be inserted into the inner leaf of a non-combustible wall. During building work the cavity must not be bridged other than by the ducts provided. Ensure that there is no structural damage or damage to the damp course. Any combustible material in the cavity must be removed or cut back to give a minimum clearance of 75mm from the top and sides of the wall box.

1. Mark out the vertical centre line of the fire on the wall, and the 450mm wide x 560mm high opening for the 18" wall box. For the 22" wall box the opening should be 560mm wide x 560mm high (Use the box as a template if required).
2. Remove the inner wall to this size, and insert a suitable lintel if required.

3. Mark out and drill a 20mm dia. hole in the inner wall and insert a 100mm length of plastic conduit. Make good any internal masonry.
4. Mark the centre line of the flue duct on the inside of the outer wall 490mm from the base and drill a pilot hole through the outer wall

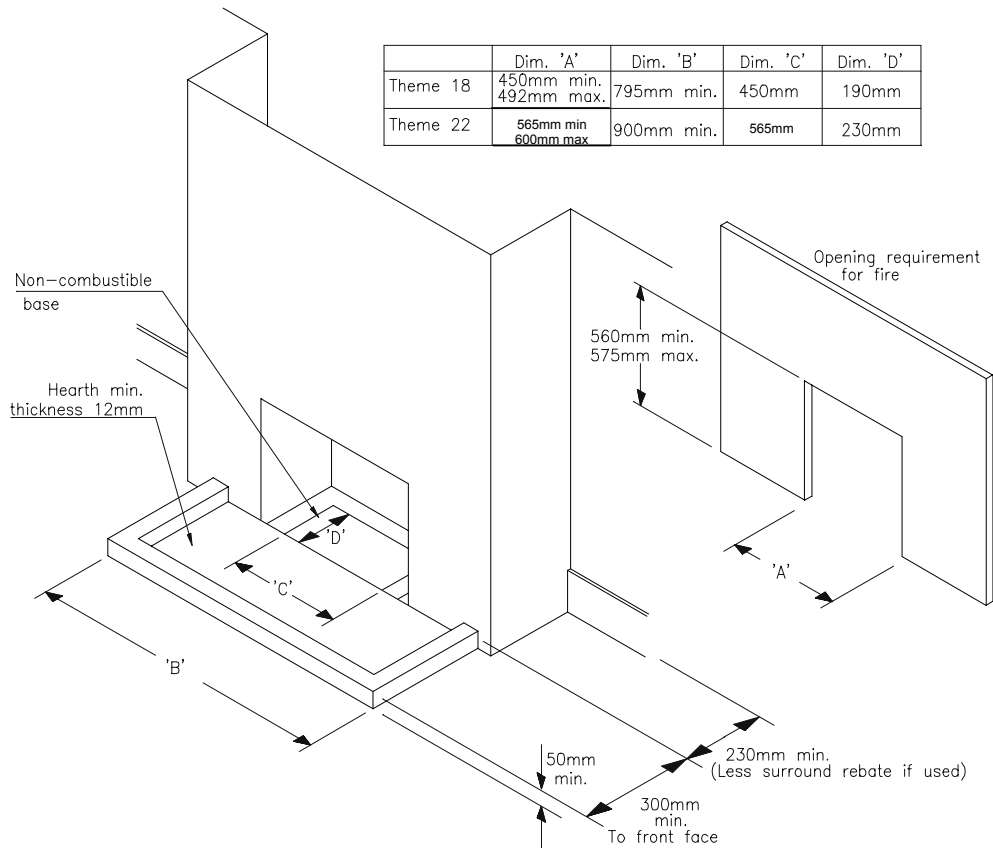
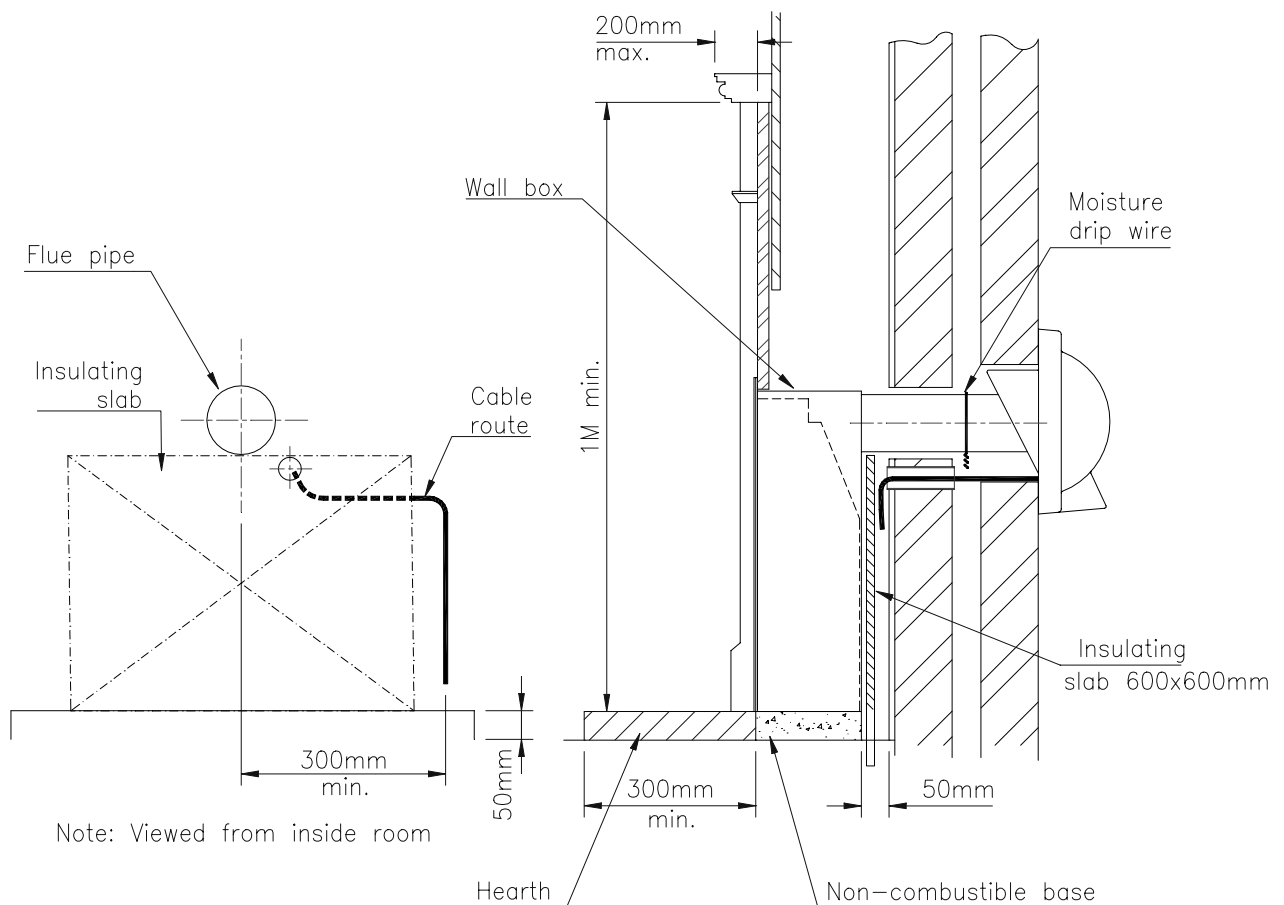

Fig. 3 False chimney breast installation



	Dim. 'A'	Dim. 'B'	Dim. 'C'	Dim. 'D'
Theme 18	450mm min. 492mm max.	795mm min.	450mm	190mm
Theme 22	565mm min 600mm max	900mm min.	565mm	230mm

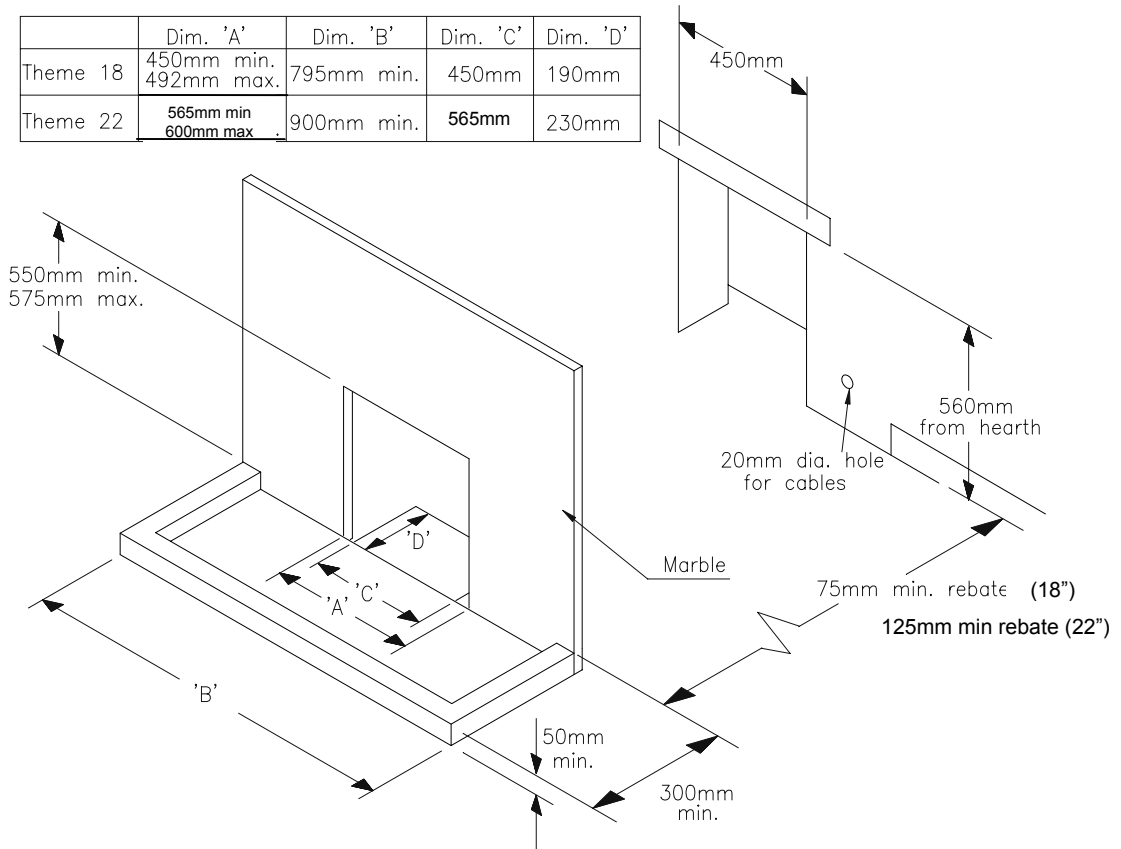
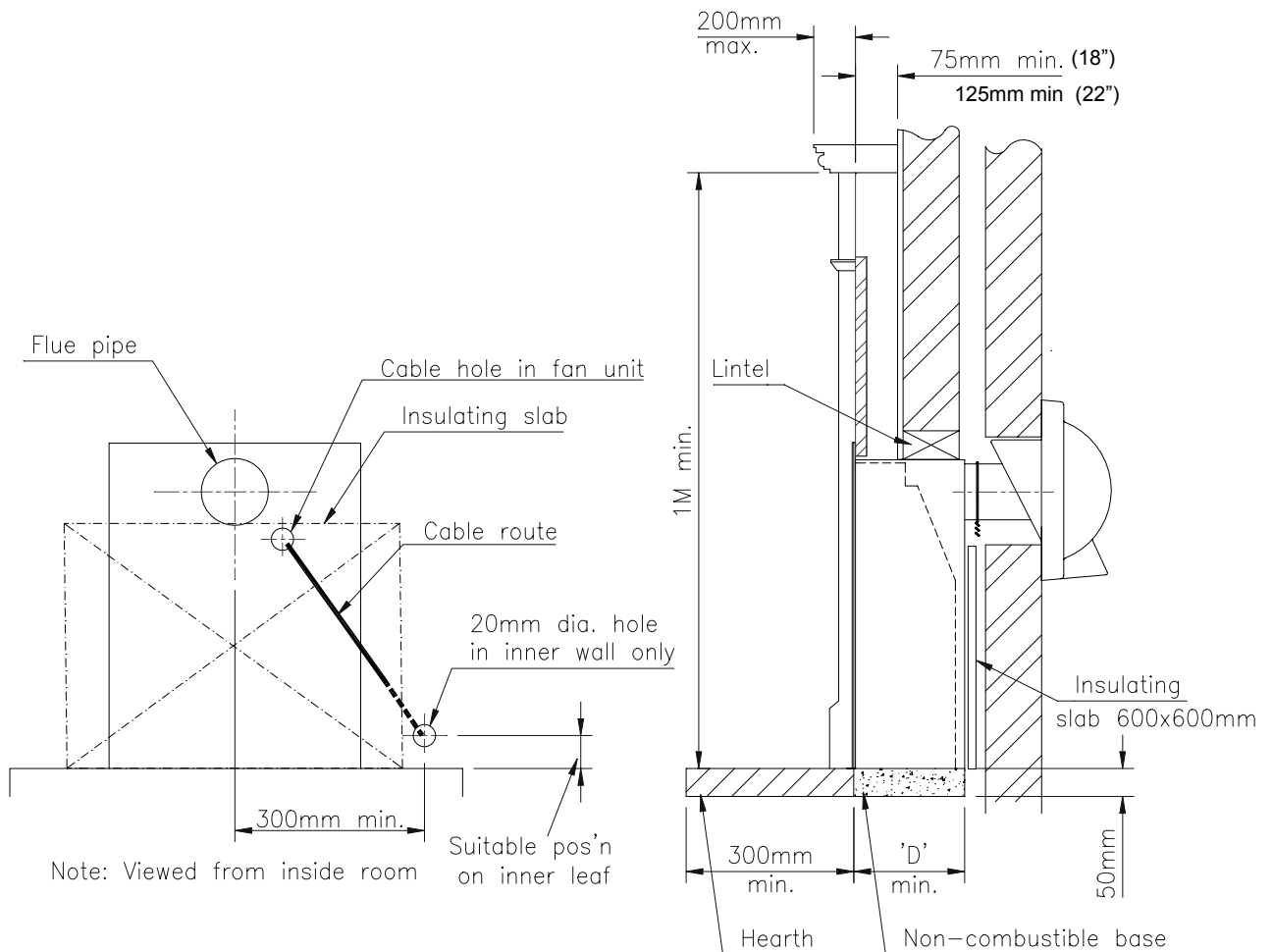

Fig. 4 Slim-profile "cavity" installation (for std. 10" cavity wall) **NOT** FOR TIMBER FRAMED BUILDINGS



### Both installations

From the outside, position the template provided over the pilot hole and mark on the wall the positions of the fan unit fixing holes.

Chain drill inside the guide lines on the template and remove brickwork.

### 3. Timber framed building

*(Must be in accordance with Institute of Gas Engineers document IGF/UP17)*

The Timber Frame Kit supplied with the Turboflue consists of:

- Sleeve
- End plate
- O' ring
- Insulation slab

*Care must be taken to protect combustible materials from contact with hot surfaces on the convector box and flue.*

Proceed as follows:

1. Mark on the inside wall the centreline of the flue outlet, which must be central between two vertical studs and mark a 185mm dia. circle.
2. Drill a pilot hole right through the inside and outside wall on the centreline.
3. With a sharp blade score round the 185mm dia. circle on the plasterboard, crosshatch within the perimeter of the circle and break out the plasterboard without damaging the vapour barrier.
4. Cut the vapour barrier 10mm less all round than the hole in the plasterboard and push back around the hole.
5. Stitch drill ply sheathing and complete the hole with a pad saw.
6. From the outside, position the template provided over the pilot hole and mark on the wall the positions of the fan unit fixing holes.
7. Chain drill inside the guide lines on the template and remove brickwork.
8. Fit the 180mm dia. sleeve from the inside, cut to length to ensure that it does not protrude more than 10mm into the cavity. Use flexible mastic to secure.
9. Push the endplate into position. (See Fig. 5)
10. Mark out on the inside wall the centreline of the 20mm dia. hole.
11. Drill through the inner skin 20mm dia.
12. Cut the 20mm dia. plastic conduit to length and fit the 'O' ring supplied to locate in the centre of the cavity to form a drip collar.
13. From the outside insert the plastic conduit through the hole in the inner wall.

**IMPORTANT:** The top, rear and sides of the appliance must be covered with a 25mm minimum thickness of fibreglass insulation.

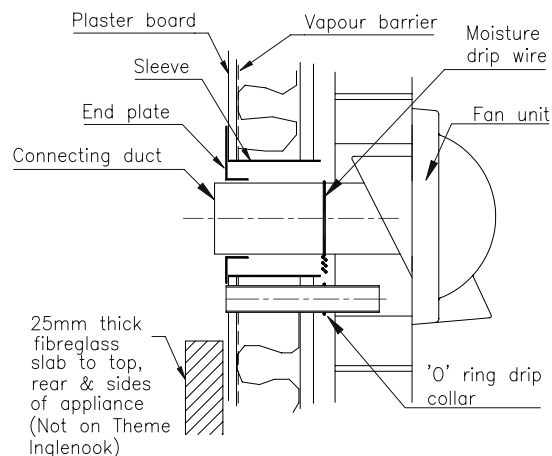

Fig. 5 Timber framed cut out

### Installation of major components

*This section describes the fitting of the connecting duct, fan unit, wall box and convector box.*

1. Remove the convection box from the wall box by removing the 2 screws in the fire back (Fig. 7).
2. Place the wall box on the non-combustible base and slide into the opening in the inner wall. Mark through the fixing holes onto the base then drill and insert the plastic plugs supplied. If securing to the base is not suitable, drill 4 holes around the flange into the surround, and insert plastic plugs.
3. Push the connecting duct through the cut-out in the wall box and the hole in the wall and temporarily secure the mounting plate to the wall box. Take care not to damage the gasket.
4. Go outside and mark the connecting duct in line with the outside face of the wall.
5. Go inside and remove the wall box once again, take off the connecting duct and cut off 85mm inside the marked line.

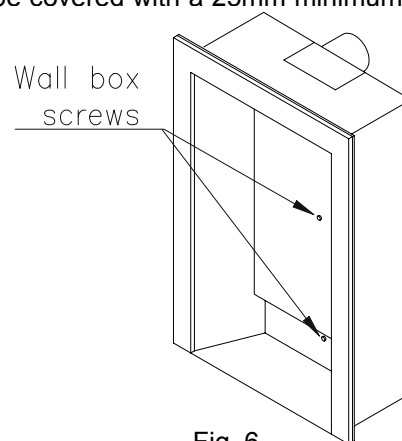

Fig. 6

6. Remove the fan unit cover (4 screws) and place to one side.
7. Using the template as a guide, drill the outer wall for fixing the fan unit and insert the plastic plugs provided.
8. From outside feed the 3 cables from the fan unit through the opening in the wall, then feed the mains and switch cables through the 20mm plastic conduit in the inner wall.
9. Secure the fan unit to the wall using the screws provided into the plastic plugs.
10. CARRY OUT ELECTRICAL INSTALLATION STEPS 1-5
11. Install the fire surround or false chimneybreast if not already fitted.
12. Position the wall box on the non-combustible base and feed the gas supply pipe through the left hand rear grommet hole. The burner supply cable with 4-way plug should be passed through the right hand grommet hole. Bring through only sufficient to reach the burner, coiling up any surplus behind the insulating slab.
13. Secure the wall box in its final position using the screws provided.
14. Wrap the wire provided round the connecting duct, twisting the ends to secure. Position the wire so that it will be sited centrally in the cavity space, with the twist underneath to form a drip collar.
15. Slide the connecting duct through the back of the wall box into the spigot on the fan unit fitted to the outside wall. Take care not to damage the seal in this spigot. *If the seal is damaged it will have to be replaced.* If the duct is difficult to engage, coat the seal with liquid soap. Secure inside the wall box with the screws provided, ensuring that the gasket is positioned correctly.
16. COMPLETE ELECTRICAL INSTALLATION STEPS 6 and 7.
17. **Remove the protective cover from the fan motor.**
18. Fit the fan unit cover with the four screws provided.
19. If the wall box is not fixed through its base, then secure the assembly to the surround using 4 screws into the previously inserted plastic plugs.
20. Slide the convection box into the wall box, feeding the gas pipe and cables through the appropriate grommets.
21. Secure the convection box through the back to the wall box with the screws provided.

### Electrical installation

***NOTE: THIS APPLIANCE MUST BE EARTHED;*** Electrical-wiring work must conform to current I.E.E. Wiring Regulations.

*All cables should be routed as shown in Figs 9a & 14.*

### **IMPORTANT**

1. **Place the insulation slab in front of the cables** and fix to the wall with masonry nails and washers supplied, taking care not to damage the cables. See Figs. 9a, 14 and 7.
2. The mains cable should be trimmed to length and connected to a switched fused spur (3A fuse) with at least 3mm contact separation in all poles.
3. Decide with the user on a suitable location for the switch plate and fit the galvanised back box.
4. Route the 7-core cable as required, trim to length and connect to the rear of the switch plate taking care to connect the cores as indicated on the label.
5. Bring the 4-way plug and cable through the right hand hole in the side of the convection box ready for connection to the burner (see Fig. 9a). (Do not bring the earth cable through this hole) Coil up any excess and place between the insulation slab and the wall.
6. Connect the earth cable to the earth bolt in the convection box side, ensuring that the serrated washers are fitted as shown in Fig. 9b.
7. See Fig. 17 for a complete wiring diagram.

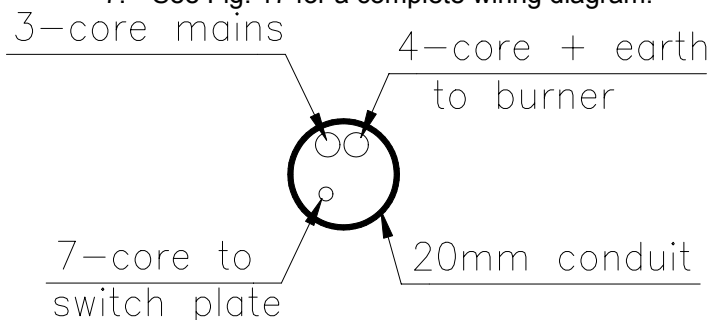

Fig. 8 Cable conduit layout

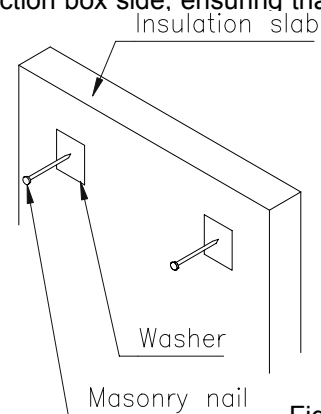

Fig. 7



## Final assembly

This section describes the installation of the burner unit

**WARNING: Always blow pipework through before connecting to appliance – contamination will permanently damage the burner.**

1. Connect the earth link lead from the burner to the earth bolt in the firebox side as shown in Fig. 14.
2. Secure the burner to the convection box using the two screws provided, through the holes in the front of the legs.
3. Connect the gas supply pipe to the inlet elbow.
4. Remove the ignition unit cover beneath the burner (Fig. 14). Route the 4-core cable as shown and plug into the printed circuit board. Fit the cable grommet into the hole in the side of the fire and replace the cover. Do not allow the cable to loop up under the burner.
5. Install the ceramics and coals. The ceramic components are fragile and should be handled with care. Refer to Figs. 11 to 13 for positioning of ceramic fibre blocks and coals.
6. Place the chair shaped back ceramic on the burner, pushing it back against the upturned edge of the burner plate.
7. Place the centre ceramic on the back ceramic pushing it back to sit comfortably between the tapered sides.
8. Spring forward the slotted front plate and slide the front ceramic down as far as the stops.
9. Remove the coals from the bag; note that there are various sizes supplied with the burner. Place them on the ceramic blocks in accordance with Fig. 12 or 13.

If a flat trim or box trim has been supplied, attach it to the fire flange by means of the magnets. If the optional canopy trim has been supplied, first remove and discard the existing front cover by undoing the two screws in its bottom edge, then secure the canopy trim using the same fixings. (See Fig. 10)

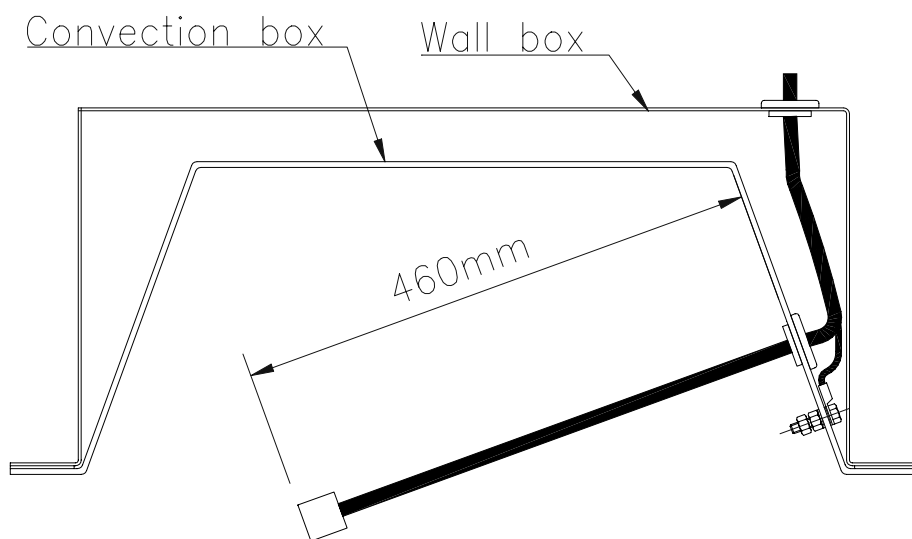

Fig. 9a

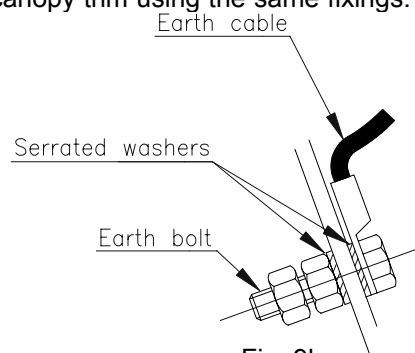

Fig. 9b

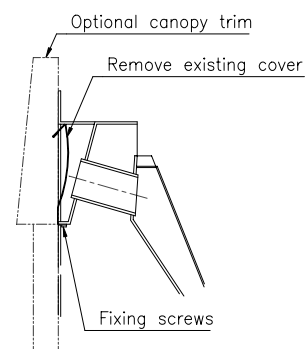

Fig. 10 Fitting canopy trim

## Leak test & pressure test

1. Turn on the main gas supply and check for gas soundness.
2. Remove pressure test screw, and fit pressure gauge to pressure test point.
3. Light the fire (see next section).
4. Press High/Low button to obtain a high flame.
5. With High flame indicated, you should have a gas pressure of  $19.0\text{mbar} \pm 1.0\text{mbar}$ .
6. Extinguish the fire by pressing the On/Off button.
7. Remove the pressure gauge and replace the pressure test screw. Check again for gas soundness.
8. Fit the front fret by hooking the support lugs at each end over the slotted front plate on the burner.

## Lighting the fire

1. Switch on the main electrical supply to the installation.
2. Press the On/Off button. The power light will come on, followed shortly by the fan light.
3. Press the ignition button for 15 seconds then release. The gas indicator light will come on and the pilot burner will ignite. *Note:* If this button is pressed for more than 30 seconds the ignition unit will automatically cease to spark. Allow 3 minutes before attempting to re-light.
4. When the ignition button is released the main burner will ignite on the low setting.
5. High or low flame may be selected by alternate presses on the Low/High button. The lights will indicate which has been selected.
6. The appearance of the flames on the natural gas version can be altered by means of the air adjustment lever positioned behind the 'ash pan' door. Moving the lever up will admit more air and produce a 'coke fire' effect. Moving it down will close off some of the air and simulate a 'coal fire' with flickering flames.
7. To turn the fire off press the On/Off button.

**NOTE:** If on pressing the On/Off button the Power neon lights but the Fan neon does not come on, switch off the mains supply at the fused spur for 2 seconds and switch on again. Repeat the lighting procedure and if the Fan neon still does not light, this indicates a fault. Check that there are no obvious obstructions to the fan outlet. If this is not the case the fault will require investigation by a service engineer.

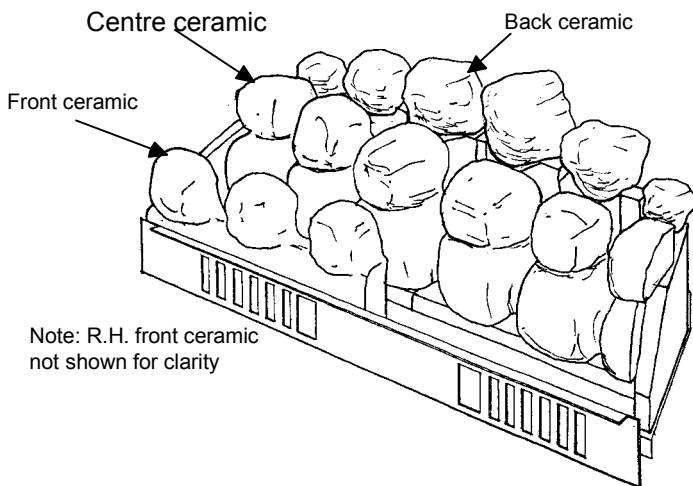

Fig. 11 Assembling the ceramic blocks (Theme 18)

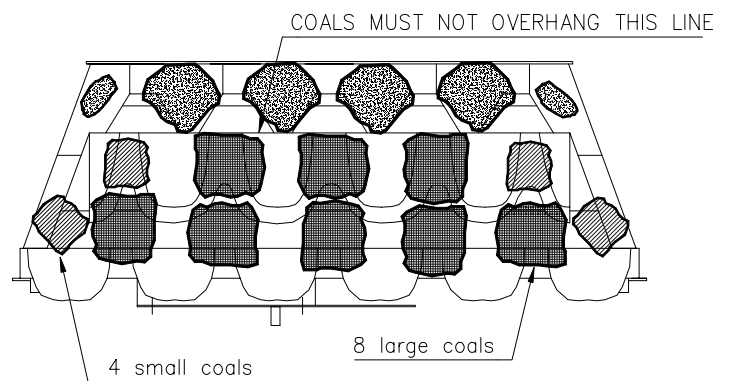
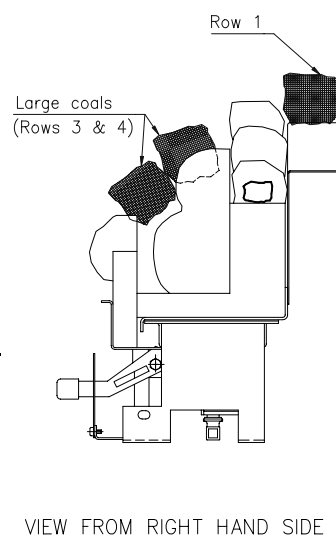
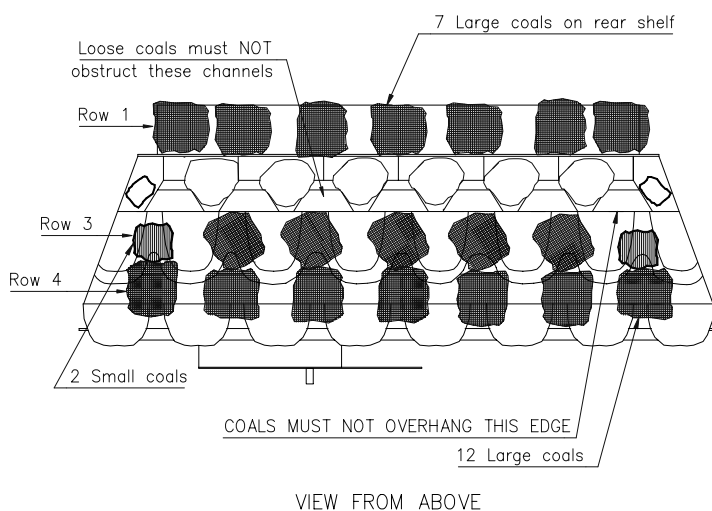

Fig. 12 Placing the loose coals



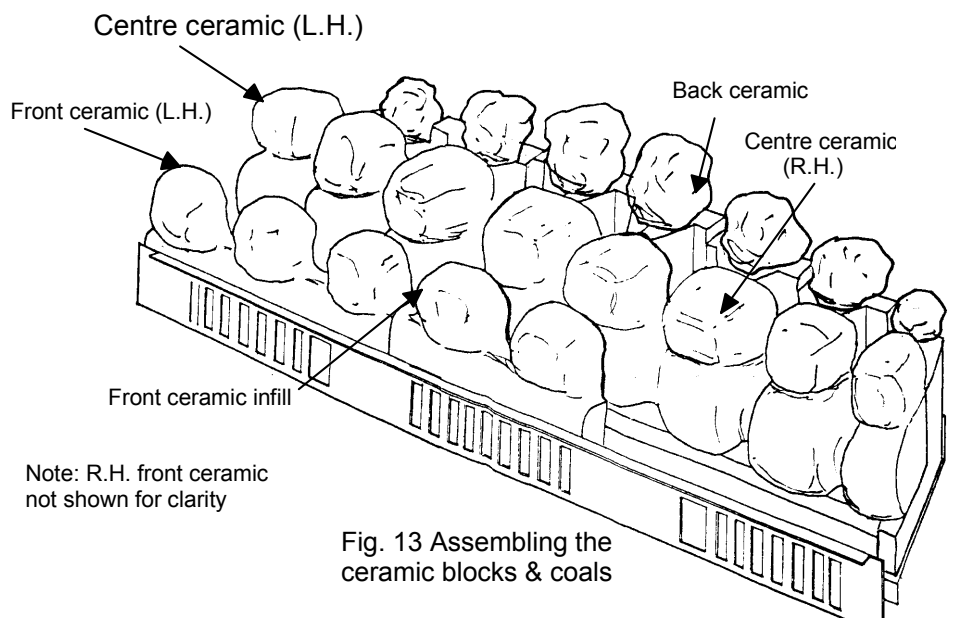
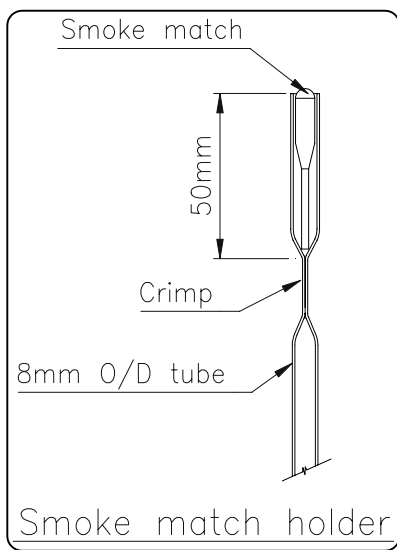

Fig. 13 Assembling the ceramic blocks & coals

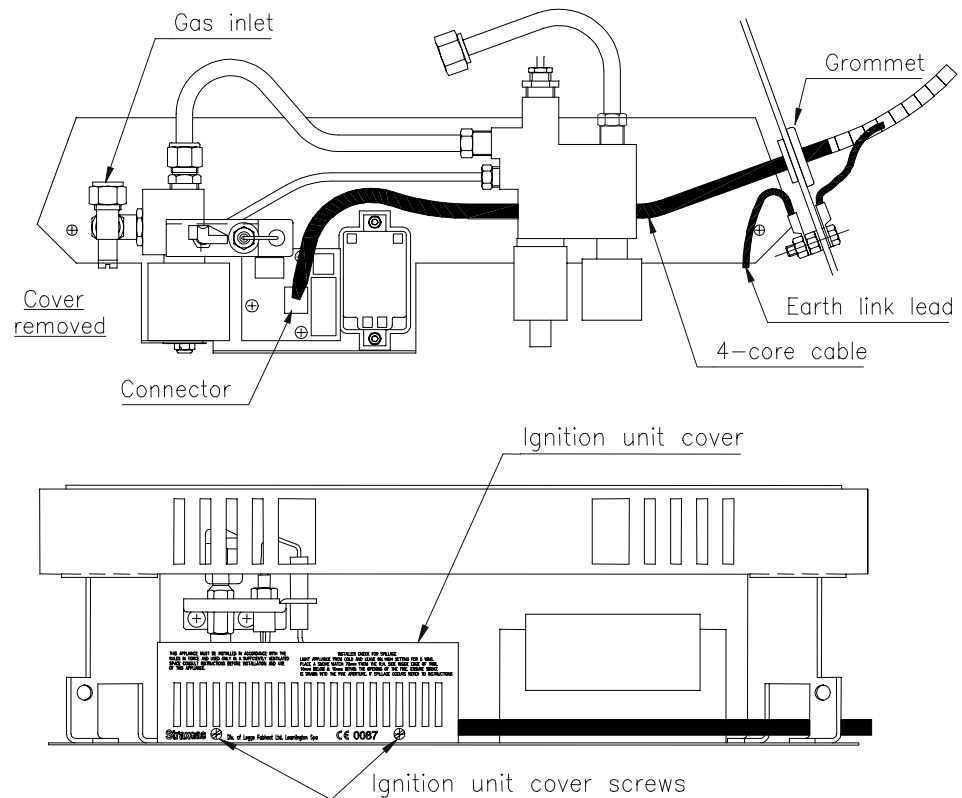

Fig. 14 Burner & ignition unit (18" shown, 22" is similar)

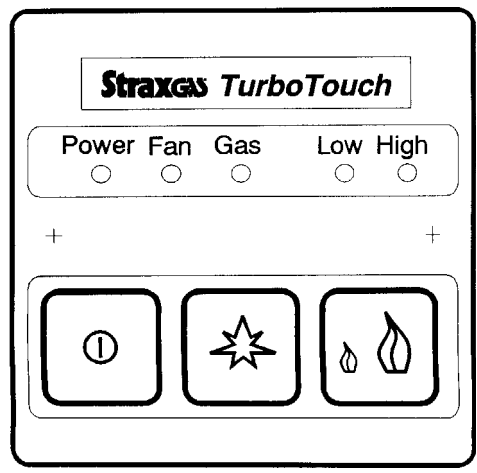

Fig. 15 Switch plate

**Check for clearance of products of combustion**

1. Light the fire.
2. Close all windows and doors.
3. After approximately 5 minutes place a smoke match (shrouded smoke match on Theme 22) 70mm from the right hand side, inside edge of the trim, 10mm below and 10mm within the opening of the fire as shown in Figs. 16a and 16b. Ensure that the smoke is drawn into the fire aperture. If spillage is detected, the cause must be discovered and the fault corrected. If the cause cannot be corrected disconnect the gas supply to the appliance and seek expert advice. NOTE: DO NOT HOLD THE SMOKE MATCH IN ANY OTHER POSITION.
4. If there is an extraction fan in a nearby room then the spillage test must be repeated with the fan turned on and any interconnecting doors between the fire and the fan location left open.
5. If there are other open flued appliances in adjoining rooms they must be checked for clearance of products of combustion when the Turboflue is in operation.

## Check operation of safety system

### Test 1

1. Light the fire
2. Block the flue outlet with a suitable plate for 6 seconds. The fire should now be extinguished and the power and fan indicators on the switch plate should be lit.

### Test 2

1. Light the fire
2. Block the flue outlet with a suitable plate for 20 seconds. The fire should now be extinguished, the fan should not be running, and no indicators on the switch plate should be lit.

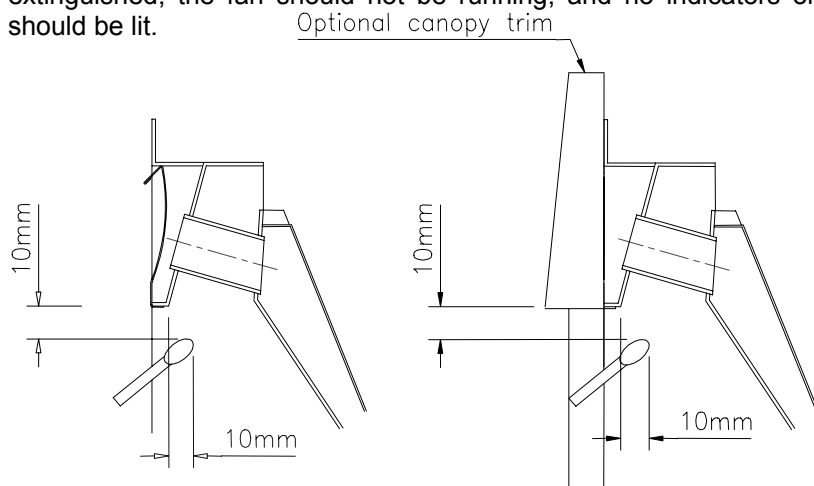

Fig. 16a  
(Std. Theme 18 & 22)

Fig. 16b  
(Std. Theme 18 & 22 with  
optional canopy trim)

---

## **Instruct the user**

1. Hand over these Installation Instructions and the User Instructions to the person who is going to use the fire and explain how to light and operate the appliance.
2. Make certain that the user is aware that the ceramic blocks and coals must be located in accordance with the instructions, and that the appliance should be serviced at regular intervals by a competent person to ensure continued safe operation.
3. Explain that this appliance is fitted with an oxygen depletion sensor incorporated into the pilot body. Should the fire repeatedly extinguish itself, the cause should be sought and remedied as this may indicate spillage into the room of combustion products.
4. Indicate the tie-on warning label which the customer must remove and read.
5. Advise the user that any smell given off by the appliance will clear away after a little use.
6. Point out that these instructions must be retained in a safe place for future use.

---

## **Maintenance**

Servicing should be carried out at least once a year by a competent person in accordance with these instructions and the relevant regulations, to ensure the safe and correct operation of the appliance.

Before commencing any service or replacement of parts, turn off the main gas and electrical supply **and ensure that the fire is cold.**

When ordering spare parts please quote appliance serial number which can be found on the data badge plate.

### Ceramics

Examine the coals and ceramic blocks for signs of excessive cracking and replace if necessary. Handle the ceramic components with care. Dust off any soot or deposits with a soft brush. Do not vacuum clean.

---

## **Replacement of parts**

With the exception of ceramic mouldings and loose coals, Oxypilot assembly and injector, there are no serviceable items. Should a fault develop contact, our service department which will advise on which assembly or assemblies to return to the factory for repair and testing.

### **Removal of burner**

1. Isolate the appliance from the mains electrical supply and turn off the gas supply by the isolation cock.
2. Disconnect the 8mm pipe from the elbow at the left hand side of the burner.
3. Remove slotted cover and disconnect the 4-way plug from the circuit board.
4. Remove earth link screw from firebox side to release earth lead.
5. Remove the 2 screws holding the burner to the convection box and lift the burner out of the opening.
6. Reassemble in the reverse order.
7. After servicing check for gas soundness.

### **Replacement of main injector(s)**

1. Remove the burner as described above.
2. Disconnect gas supply pipe to injector.
3. Unscrew injector and replace, making certain that the jet size stamping corresponds to the specification on the Data Badge plate.
4. Reassemble in reverse order.
5. Turn on the gas supply and check for soundness.

### **Replacement of ignition/pilot assembly (Oxypilot)**

1. Remove the burner as described above.
2. Disconnect ignition lead to the igniter unit.
3. Disconnect the gas supply pipe to the pilot burner.
4. Disconnect the thermocouple from the main gas valve block.
5. Carefully slacken the two terminal screws retaining the insulated thermocouple lead to the circuit board.
6. Take out the two screws securing the Oxypilot to the mounting bracket and remove the Oxypilot.
7. Lay the new Oxypilot alongside the old unit and cut the insulated lead in the same position as on the old unit. Strip back the insulation approximately 5mm.
8. Secure the new Oxypilot assembly to the bracket and reconnect, taking care not to damage the terminals on the circuit board.
9. Reassemble the appliance in reverse order.
10. Turn on the gas supply and check for gas soundness.

### **Removal of fan for cleaning**

1. Isolate from mains electrical supply.
2. Remove terminal guard if fitted.
3. Remove the Turboflue cover by undoing the four retaining screws.
4. Remove cover from grey box and disconnect motor terminals at bottom of box. Disconnect the earth cable.
5. Mark one pressure switch pipe and probe stub to identify, then pull both pipes off the probes.
6. Remove the three nuts and washers, and pull the fan head off the studs. Run the washers and nuts back on the studs to prevent loss of spacers.
7. Any accumulation of debris on the fan blades should be removed with a soft brush, and any deposits of lint removed from all components.
8. Reassemble, following steps 2 to 7 in reverse order. Carry out safety system tests 1 and 2 as detailed on page 14.

### **Supply cord**

If the mains supply cord is damaged it must be replaced by a suitably qualified person.

### **General**

Check the area in the vicinity of the fan unit for any obstruction by overgrown shrubbery, etc. which could affect the free flow of combustion products.

Following a service, a check should be made for clearance of combustion products. Follow the procedure detailed in these instructions.

## Cleaning the fire

**Black paint:** Use only a clean, lint free damp cloth. Do not use any cleaning agents.

**Brass parts:** *Fret* - Use Brasso or Duraglit ensuring that it does not come into contact with the black paint finish.

**Theme 22 brass frame** - This has a laquered finish and should only be wiped with a damp cloth. Do not use metal polish.

**IMPORTANT** - The paint finish is durable and heat resistant, however it will be damaged if plaster, cement or wallpaper paste is allowed to come into contact with it. **Protect the appliance during re-building or decorating work.**

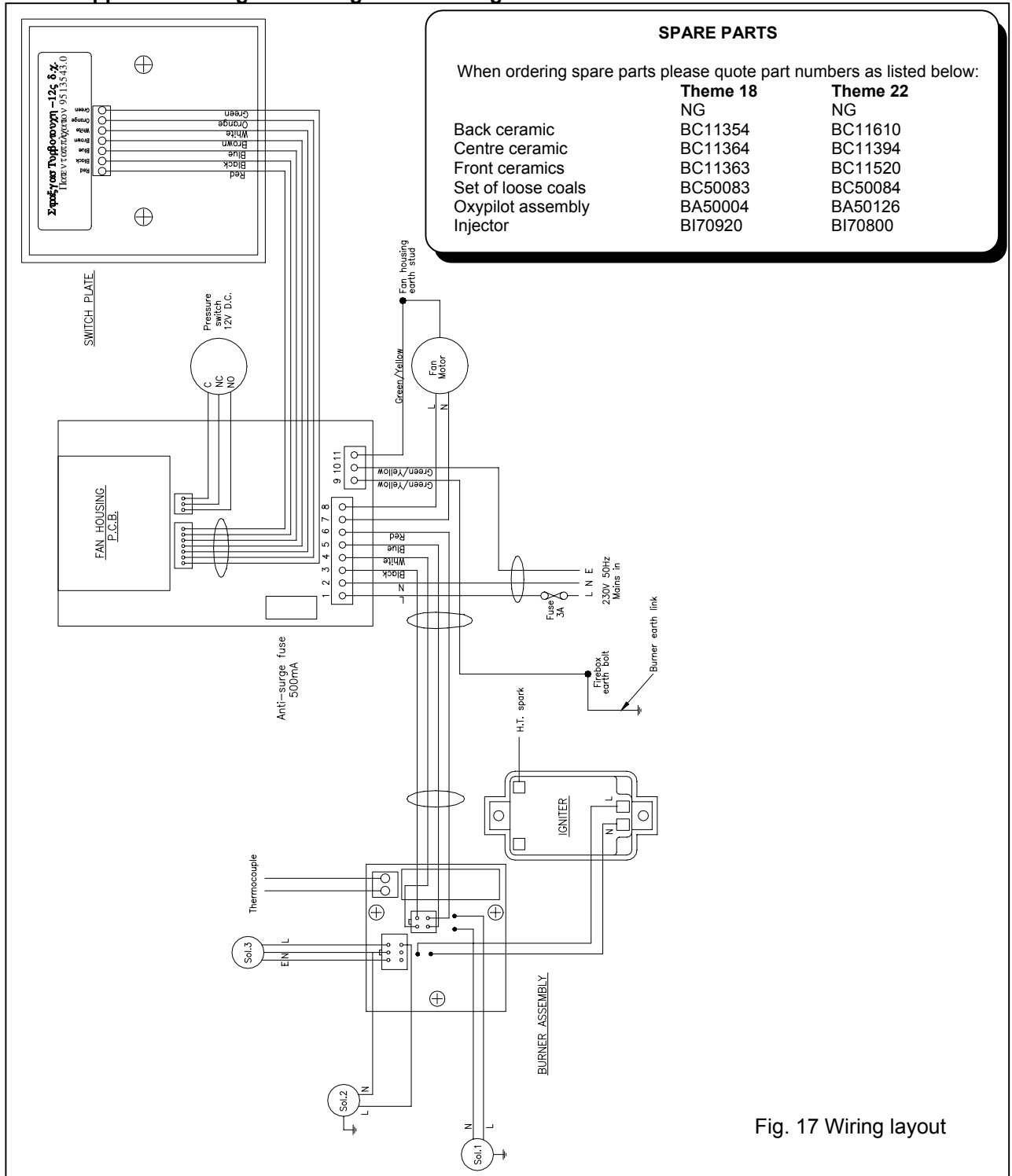

NOTE: No liability can be accepted unless this product has been installed and operated strictly in accordance with these manufacturer's instructions  
 U.K. Registered Design 2040268. British Patent Application 9414887.1  
 Design right reserved © Legge Fabheat Ltd.