



OGURA Electro Magnetic Clutches & Brakes



# Electro Magnetic Clutches & Brakes



**Ogura Industrial Corp.**  
100 Randolph Road  
Somerset, New Jersey 08873  
Phone: 732-271-7361  
Fax: 732-271-7580  
Email: [info@ogura-clutch.com](mailto:info@ogura-clutch.com)  
Website: <http://www.ogura-clutch.com>

Superior Technology in Motion Control



# **OGURA**

## **ELECTROMAGNETIC CLUTCHES & BRAKES**

The Ogura Clutch Company was founded in 1938. Since that time, Ogura has grown to be the largest manufacturer of electromagnetic clutches in the world, with current manufacturing capacity exceeding 30 million units per year. Ogura has technical and manufacturing representation via 14 manufacturing plants in Asia, North America, South America and Europe.

Ogura's numerous quality awards reflect a desire for continuous improvement which we apply not only to our products, but also to our personnel. We believe the cornerstone of quality begins with people. This is why our personnel are continually trained on the latest manufacturing techniques and design principles. Our plants currently conform to ISO9001, ISO14001 and TS16949 standards.

We welcome the opportunity to put our manufacturing and engineering skills to work for you. If for some reason your requirement does not fit within the product lines shown in this catalogue please contact us directly. We have over 3,000 designs to choose from.

**Superior Technology in Motion Control**



# INDEX BY TYPE

	DESCRIPTION	REFERENCE TORQUE RANGE	PAGE	
<b>◀ ELECTROMAGNETIC CLUTCHES &amp; BRAKES ▶</b>				
MODEL <b>MIC</b>	One-piece design, zero backlash, custom gear or hub	2.2 ~ 7.1 in-lbs	4	<b>MIC</b>
MODEL <b>AM</b>	Universal output hub, zero backlash	2.2 ~ 71 in-lbs	7 / 50	<b>AM</b>
MODEL <b>V</b>	Flexible mounting, zero backlash, self-adjusting designs available	5.2 ~ 44 ft-lbs	10 / 53	<b>V</b>
MODEL <b>CT/B</b>	Self-adjusting for wear, interchangeable with some U.S. manufacturers	8 ~ 50 ft-lbs	19 / 62	<b>CT/B</b>
MODEL <b>MMC</b>	Protective coating, high torque	37 ~ 1475 ft-lbs	26	<b>MMC</b>
MODEL <b>MP</b>	Foot-mounted, for high-cycle applications	4.4 ~ 443 in-lbs	80	<b>MP</b>
MODEL <b>TM</b>	Zero backlash with standard or inverted hub	4.4 ~ 148 ft-lbs	21 / 64	<b>TM</b>
MODEL <b>AMU-C</b>	Foot-mounted, zero-backlash	2.2 ~ 71 in-lbs	75	<b>AMU-C</b>
MODEL <b>VSAU</b>	Foot-mounted, zero-backlash	8.9 ~ 37 in-lbs	78	<b>VSAU</b>
<b>◀ ELECTROMAGNETIC POWER-OFF BRAKES ▶</b>				
MODEL <b>MCNB</b>	Zero backlash	1.8 ~ 8.9 in-lbs	84	<b>MCNB</b>
MODEL <b>FNB</b>	For holding and emergency stop only, flat design	8.9 ~ 71 in-lbs	89	<b>FNB</b>
MODEL <b>SNB</b>	For stopping and holding	0.7 ~ 74 ft-lbs	92	<b>SNB</b>
MODEL <b>RNB</b>	For holding and emergency stop only, zero-backlash designs available	1.5 ~ 148 ft-lbs	97	<b>RNB</b>
MODEL <b>MNB</b>	For stopping and holding, mechanically adjustable torque	1.5 ~ 590 ft-lbs	102	<b>MNB</b>
MODEL <b>PMB</b>	Permanent magnet brake, interchangeable with some other manufacturers	3.5 ~ 266 in-lbs	107	<b>PMB</b>
<b>◀ MULTIPLE DISK ELECTROMAGNETIC CLUTCHES &amp; BRAKES ▶</b>				
MODEL <b>MD</b>	High torque, for dry applications	13 ~ 6196 ft-lbs	31 / 69	<b>MD</b>
MODEL <b>MW</b>	High torque, for use in oil applications	18 ~ 8851 ft-lbs	37 / 72	<b>MW</b>
<b>◀ TOOTH CLUTCHES ▶</b>				
MODEL <b>MZ/MZS</b>	High torque, no slip, single-position design	18 ~ 2950 ft-lbs	44	<b>MZ/MZS</b>
<b>◀ MAGNETIC PARTICLE CLUTCHES &amp; BRAKES ▶</b>				
MODEL <b>OPL</b>	Low cost, pre-set torque, no power required	0.3 ~ 3.5 in-lbs	109	<b>OPL</b>
MODEL <b>OP</b>	Electrically variable torque, fast response	4.4 ~ 71 in-lbs	123	<b>OP</b>
MODEL <b>PC/PB</b>	Electrically variable torque, high heat dissipation	8.9 ~ 148 ft-lbs	129	<b>PC/PB</b>
<b>◀ HYSTERESIS CLUTCHES &amp; BRAKES ▶</b>				
MODEL <b>PHT</b>	Mechanically adjustable torque, no power required	0 ~ 62 in-lbs	114	<b>PHT</b>
MODEL <b>H</b>	Electrically variable torque, minimal drag	0.4 ~ 8.9 in-lbs	132	<b>H</b>
<b>◀ SPECIAL CLUTCHES ▶</b>				
MODEL <b>PET</b>	Eddy current clutch/brake, torque proportional to slip speed	0.18 ~ 8.9 in-lbs	120	<b>PET</b>

# INDEX BY APPLICATION

	DESCRIPTION	REFERENCE TORQUE RANGE	PAGE
<b>◀ START ▶</b>			
<b>CLUTCHES FOR STARTING ROTATIONAL LOAD</b>			
MODEL <b>MIC</b>	One-piece design, zero-backlash, custom gear or hub	2.2 ~ 7.1 in-lbs	4 ~ 6
MODEL <b>AMC</b>	Universal output hub, zero backlash	2.2 ~ 71 in-lbs	7 ~ 9
MODEL <b>VC</b>	Flexible mounting, zero-backlash, self-adjusting designs available	5.2 ~ 44 ft-lbs	10 ~ 18
MODEL <b>CT</b>	Self-adjusting for wear, interchangeable with some U.S. manufacturers	20 ~ 50 ft-lbs	19 ~ 20
MODEL <b>TMC/TMF</b>	Zero backlash, brakes come with hubs	4.4 ~ 148 ft-lbs	21 ~ 25
MODEL <b>MMC</b>	Protective coating, high torque	37 ~ 1475 ft-lbs	26 ~ 30
MODEL <b>MDC</b>	High-torque multiple-disk clutch, for use in dry applications	13 ~ 6196 ft-lbs	31 ~ 36
MODEL <b>MWC</b>	High-torque multiple-disk clutch, for use in oil applications	18 ~ 8851 ft-lbs	37 ~ 43
MODEL <b>MZ/MZS</b>	High-torque tooth clutch, no slip, single-position designs available	18 ~ 2950 ft-lbs	44 ~ 49
<b>◀ STOP ▶</b>			
<b>BRAKES FOR STOPPING ROTATIONAL LOAD</b>			
MODEL <b>AMB</b>	Zero-backlash	2.2 ~ 71 in-lbs	50 ~ 52
MODEL <b>VB</b>	Flexible mounting, zero-backlash, self-adjusting designs available	5.2 ~ 44 ft-lbs	53 ~ 61
MODEL <b>B</b>	Self-adjusting for wear, interchangeable with some U.S. manufacturers	8 ~ 50 ft-lbs	62 ~ 63
MODEL <b>TMB</b>	Zero backlash with standard or inverted hub	4.4 ~ 148 ft-lbs	64 ~ 68
MODEL <b>MDB</b>	High-torque multiple-disk brake, for use in dry applications	13 ~ 826 ft-lbs	69 ~ 71
MODEL <b>MWB</b>	High-torque multiple-disk brake, for use in oil applications	18 ~ 2360 ft-lbs	72 ~ 74
<b>◀ START / STOP ▶</b>			
<b>COMBINATION CLUTCH/BRAKE UNITS FOR STARTING AND STOPPING ROTATIONAL LOAD</b>			
MODEL <b>AMU-C</b>	Foot-mounted, zero-backlash	2.2 ~ 71 in-lbs	75 ~ 77
MODEL <b>VSAU</b>	Foot-mounted, zero-backlash	8.9 ~ 37 ft-lbs	78 ~ 79
MODEL <b>MP</b>	Foot-mounted, for high-cycle applications	4.4 ~ 443 in-lbs	80 ~ 83
<b>◀ HOLD ▶</b>			
<b>POWER-OFF BRAKES FOR STOPPING OR HOLDING ROTATIONAL LOAD</b>			
MODEL <b>MCNB/MCLB</b>	Zero-backlash	1.8 ~ 8.9 in-lbs	84 ~ 88
MODEL <b>FNB</b>	For holding and emergency stop only, flat design	8.9 ~ 71 in-lbs	89 ~ 91
MODEL <b>SNB</b>	For stopping and holding	0.7 ~ 74 ft-lbs	92 ~ 96
MODEL <b>RNB/RNB-Z</b>	For holding and emergency stop only, zero-backlash designs available	1.5 ~ 148 ft-lbs	97 ~ 101
MODEL <b>MNB</b>	For stopping and holding, mechanically adjustable torque	1.5 ~ 590 ft-lbs	102 ~ 106
MODEL <b>PMB</b>	Permanent magnet brake, interchangeable with some other manufacturers	3.5 ~ 266 in-lbs	107 ~ 108
<b>◀ SLIP ▶</b>			
<b>SLIP CLUTCHES AND BRAKES FOR TENSION CONTROL OR TORQUE LIMITING FUNCTION</b>			
MODEL <b>OPL</b>	Mag-particle torque limiter, low cost, pre-set torque, no power required	0.3 ~ 3.5 in-lbs	109 ~ 113
MODEL <b>PHT</b>	Hysteresis torque limiter, mechanically adjustable torque, no power required	0 ~ 62 in-lbs	114 ~ 119
MODEL <b>PET</b>	Eddy current clutch/brake, torque proportional to slip speed	0.18 ~ 8.9 in-lbs	120 ~ 122
MODEL <b>OP</b>	Mag-particle clutch/brake, electrically variable torque	4.4 ~ 71 in-lbs	123 ~ 128
MODEL <b>PC/PB</b>	Mag-particle clutch/brake, electrically variable torque, high heat dissipation	8.9 ~ 148 ft-lbs	129 ~ 131
MODEL <b>H</b>	Hysteresis clutch/brake, electrically variable torque, minimal drag	0.4 ~ 8.9 in-lbs	132 ~ 138



# MIC

S E R I E S

## MICRO ELECTROMAGNETIC CLUTCH

Torque Range: 2.2 ~ 7.1 in-lbs

Torque Range: 0.25 ~ 0.8 N-m



## FEATURES

### CUSTOM-MOLDED GEAR

The MIC assembly includes a custom-molded gear or timing pulley designed to your specifications.

### ONE-PIECE ASSEMBLY

The entire assembly is delivered pre-assembled, so it simply slides onto the shaft. There are no adjustments to make or gaps to set.

### BI-DIRECTIONAL OPERATION

The clutch has the ability to drive clockwise or counterclockwise.

### PERMANENT MAGNET RETURN

All standard units come with a permanent magnet armature return attached to the inside of the gear. This provides a fast and smooth disengagement of the armature when power is released to the clutch coil.

### ZERO BACKLASH OPTION

If needed the armature can incorporate a one-piece spring that eliminates backlash.

### LONG LIFE

Special bushings allow for millions of operating cycles for most applications.

### D-CUT BORE

The bore of the clutch is made to fit a D-cut shaft to simplify installation and eliminate the need for set screws.

### TWO CLUTCH POWER CONNECTION OPTIONS AVAILABLE

MIC clutches can come complete with a lead wire and a customer's specified terminal or the standard connector built into the clutch coil housing.



MIC

# MIC-E

## Micro EM Clutch

Types: 2.5, 5, 8

[ EM: Electromagnet ]

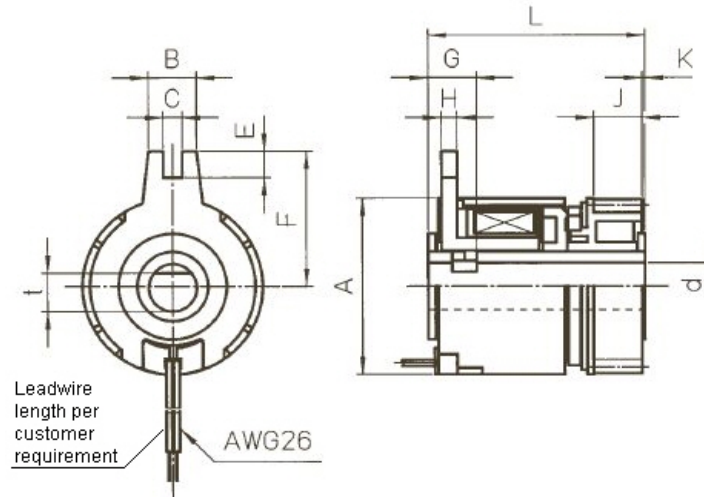

[ Special Order ]

MIC		2.5E		5E		8E	
Static Torque [in-lbs / N-m]		2.2 / 0.25		4.4 / 0.5		7.1 / 0.8	
Coil (20°C)	Voltage [DC-V]	24					
	Resistance [ $\Omega$ ]	172		150		150	
	Wattage [W]	3.4		3.8		3.8	
Armature	Pull-In Time <sup>2</sup> [ms]	6		8		10	
	Release Time <sup>2</sup> [ms]	20		25		30	
Bore [mm]	d	6	8	6	8	6	8
	t	5	6.5	5	6.5	5	6.5
Dimensions [mm]	A	26		30		34.2	
	B	8		8		8	
	C	3.2		3.2		3.2	
	E	4		4.5		4.5	
	F	18		23		23	
	G	8		8		8	
	H	2		2.6		2.6	
	J	5		8		8	
K	0.5		0.5		0.5		
L	29		36		36		
Weight [lbs / kg]		0.12 / 0.05		0.21 / 0.10		0.26 / 0.12	

[ Note 1 : Gear shown for reference only - to be supplied with custom gear or hub ]

[ 1" = 25.4mm ]

# MIC-NE

## Micro EM Clutch

Types: 2.5, 5, 8

[ EM: Electromagnet ]

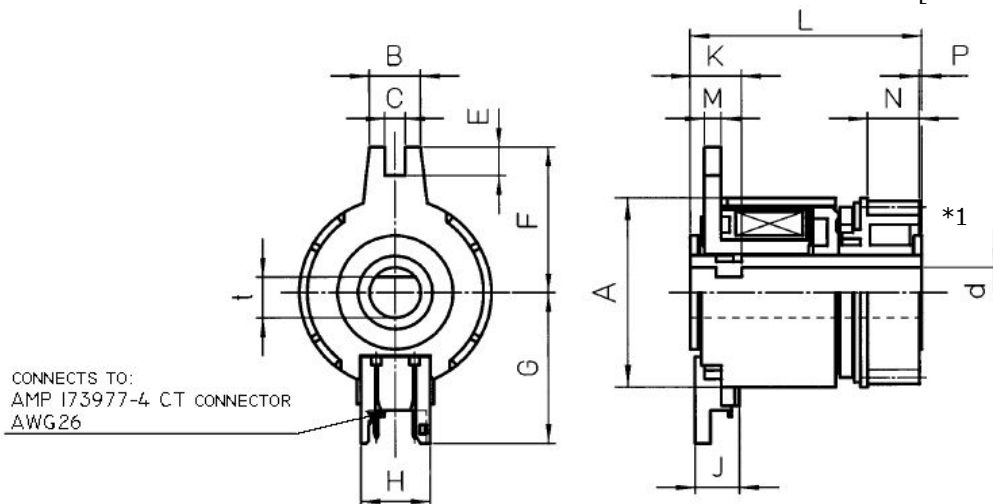

[ Special Order ]

MIC		2.5NE		5NE		8NE	
Static Torque [in-lbs / N-m]		2.2 / 0.25		4.4 / 0.5		7.1 / 0.8	
Coil (20°C)	Voltage [DC-V]	24					
	Resistance [Ω]	172		155		155	
	Wattage [W]	3.4		3.7		3.7	
Armature	Pull-In Time <sup>2</sup> [ms]	6		8		10	
	Release Time <sup>2</sup> [ms]	20		25		30	
Bore [mm]	d	6	8	6	8	6	8
	t	5	6.5	5	6.5	5	6.5
Dimensions [mm]	A	26		30		34.2	
	B	8		8		8	
	C	3.2		3.2		3.2	
	E	4		4.5		4.5	
	F	18		23		23	
	G	23		24		24	
	H	11		11		11	
	J	7.1		7.1		7.1	
	K	8		8		8	
	L	29		36		36	
	M	2		2.6		2.6	
N	5		8		8		
P	0.5		0.5		0.5		
Weight [lbs / kg]		0.12 / 0.05		0.21 / 0.10		0.26 / 0.12	

[ Note 1 : Gear shown for reference only - to be supplied with custom gear or hub ]

[ 1" = 25.4mm ]



# AMC

S E R I E S

## ELECTROMAGNETIC CLUTCH

Torque Range: 2.2 ~ 71 in-lbs

Torque Range: 0.25 ~ 8 N-m



## FEATURES

### EASY MOUNTING AND MAINTENANCE

The clutch field is mounted to the rotor with ball bearings, providing easy installation and reducing maintenance requirements.

### ZERO BACKLASH

By mounting the armature to the hub via leaf springs, backlash is minimized and armature rattle is eliminated.

### CONTROLLABLE RESPONSE TIME

Variations in acceleration or deceleration times and slip torque can be achieved by controlling the applied current.

### FAST RESPONSE

Elimination of splines provides faster response and high performance by overcoming friction in the armature and hub.

### HIGH HEAT DISSIPATION

The AM series units perform relentlessly year after year, even in heavy duty applications, due to their excellent heat dissipation.



AMC

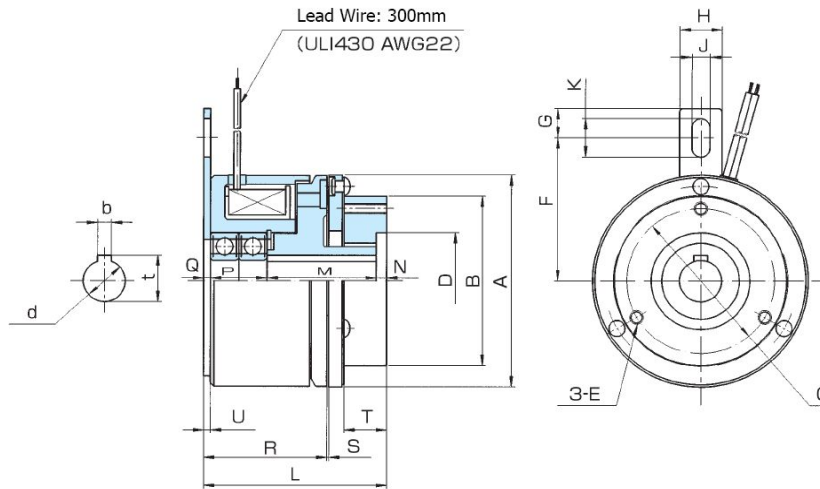

AMC		2.5	5	10	20	40	80
Static Torque [in-lbs / N-m]		2.2 / 0.25	4.4 / 0.5	8.9 / 1	18 / 2	35 / 4	71 / 8
Coil (20°C)	Voltage [DC-V]	24					
	Current [A]	0.13	0.17	0.25	0.26	0.38	0.48
	Resistance [Ω]	192	144	96	94	64	50
	Wattage [W]	3	4	6	6.1	9	11.5
	Time Constant [ms]	5	8	11	13	26	33
Armature	Pull-In Time [ms]	11	12	18	20	35	39
	Release Time [ms]	16	20	25	25	45	48
Torque Build-Up Time [ms]		15	17	27	35	55	60
Max Allowable Speed [rpm]		3600	3600	3600	3600	3600	3600
Moment of Inertia (J) [kg-cm <sup>2</sup> ]	Rotor	0.048	0.075	0.145	0.29	0.715	1.26
	Armature	0.04	0.06	0.128	0.26	0.618	1.22
Max Air Gap Until Adjustment [mm]		0.4	0.45	0.55	0.6	0.7	0.7
Total Energy Until Adjustment [J]		2.8 x 10 <sup>6</sup>	4.5 x 10 <sup>6</sup>	7.5 x 10 <sup>6</sup>	1.2 x 10 <sup>7</sup>	1.8 x 10 <sup>7</sup>	2.7 x 10 <sup>7</sup>
Total Energy Until Life [J]		8.7 x 10 <sup>6</sup>	1.4 x 10 <sup>7</sup>	2.3 x 10 <sup>7</sup>	3.8 x 10 <sup>7</sup>	5.8 x 10 <sup>7</sup>	8.5 x 10 <sup>7</sup>
Max Work Rate [W]		18	20	26	30	40	55
Bore [mm]	dH7	6	6	8	10	12	15
Key Way [mm]	bE9	2	2	2.5	4	4	5
	t+0.1/-0	6.9	6.9	8.9	11.5	13.5	17
Dimensions [mm]	A	35	40	46	51	61	70
	B	26.5	26.5	35	44	49	54
	C	22	22	30	38	42	46
	DH8	15	15	22	26	28	32
	E	M3	M3	M3	M4	M4	M4
	F	28.5	28.5	36	38	41.5	41.5
	G	6.5	6.5	7	7	8.5	8.5
	H	8	8	10	10	12	12
	J	3.2	3.2	4.2	4.2	5.2	5.2
	K	7.5	7.5	9.5	9.5	11.2	11.2
	L	32.6	32.6	40.9	45.1	52	54
	M	19	19	22.3	24.5	31	31
	N	2	2	2.5	3	3	3
	P	10	10	14	16	16	18
	Q	1.6	1.6	2.1	1.6	2	2
	R	22.4	22.4	28.1	30.6	35	36
S	0.2	0.2	0.25	0.25	0.3	0.3	
T	7.3	7.3	9.8	9.5	12.2	12.1	
U	1.6	1.6	1.6	1.6	2	2	
Recommended Hub Bearing		696ZZ	696ZZ	608ZZ	6000ZZ	6001ZZ	6002ZZ
Weight [lbs / kg]		0.31 / 0.14	0.41 / 0.19	0.66 / 0.30	0.9 / 0.4	1.6 / 0.7	2.3 / 1.1

# AMC: TYPICAL INSTALLATION

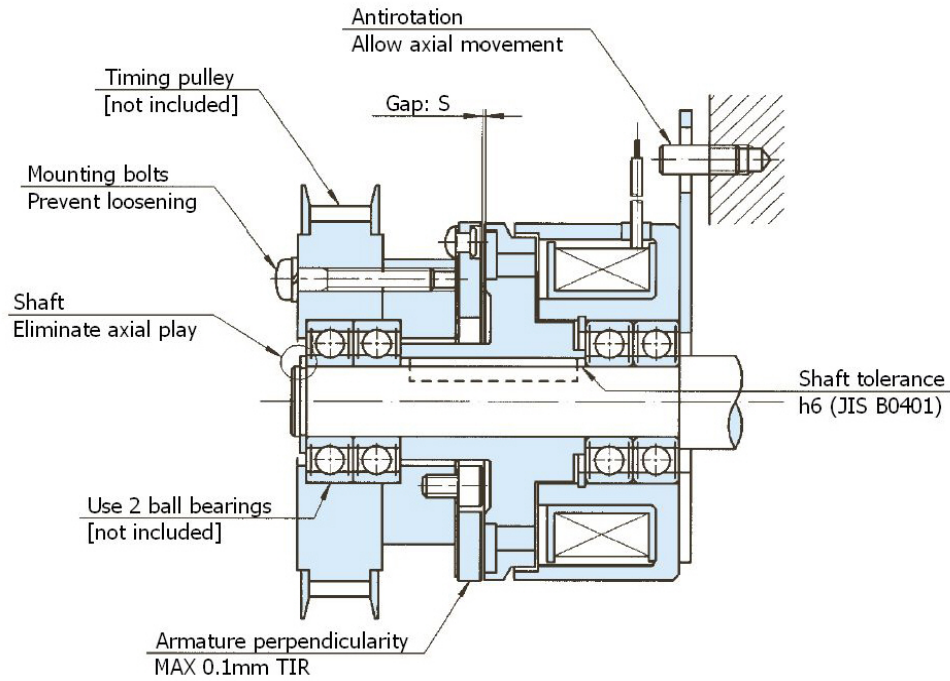

# AMC: TORQUE CHARACTERISTIC & MAX WORK RATE

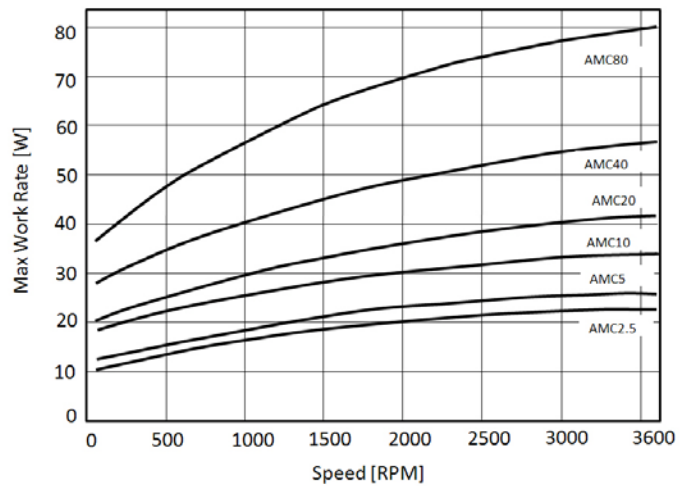
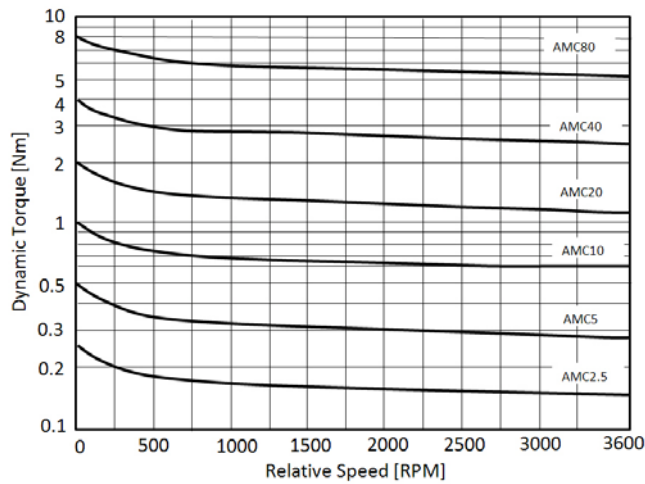



# VC

S E R I E S

## ELECTROMAGNETIC CLUTCH

Torque Range: 4.4 ~ 44 ft-lbs

Torque Range: 6 ~ 60 N-m



## FEATURES

### FAST RESPONSE

The V series clutches are dry type single disc units. This ensures fast response in high speed, high cycle applications.

### ZERO BACKLASH

The armature is mounted to the hub by special leaf springs to provide minimal backlash and no armature rattle.

### HIGH TORQUE VERSIONS AVAILABLE (H option)

Both standard units and high torque (H) versions are shown in the following data sheets. The high torque versions have identical diameters to the standard versions, however they are slightly longer to allow for a higher power coil.

### AUTOMATIC GAP ADJUSTMENT (OPTIONAL)

The air gap is automatically adjusted as the friction surfaces wear during the entire life of the unit, increasing longevity by 50%.

### QUIET ARMATURE (OPTION S)

To help dampen the noise that sometimes occurs during engagement, Ogura has developed a quiet armature option that is available on all V series models.

### ONE-PIECE DESIGN (OPTION P)

One-piece design simplifies mounting.

### COMPACT DESIGN

The compact design of the V-series reduces mounting requirements during installation.



VCE/VCEH



VCE-P/VCEH-P



VCEHA



VSAU



VCS/VCSH



VCS-P/VCSH-P



VCSHA

# VCE / VCS

## EM Clutch

Types: 0.6, 1.2, 2.5, 5, 10, 20

[ EM: Electromagnet ]

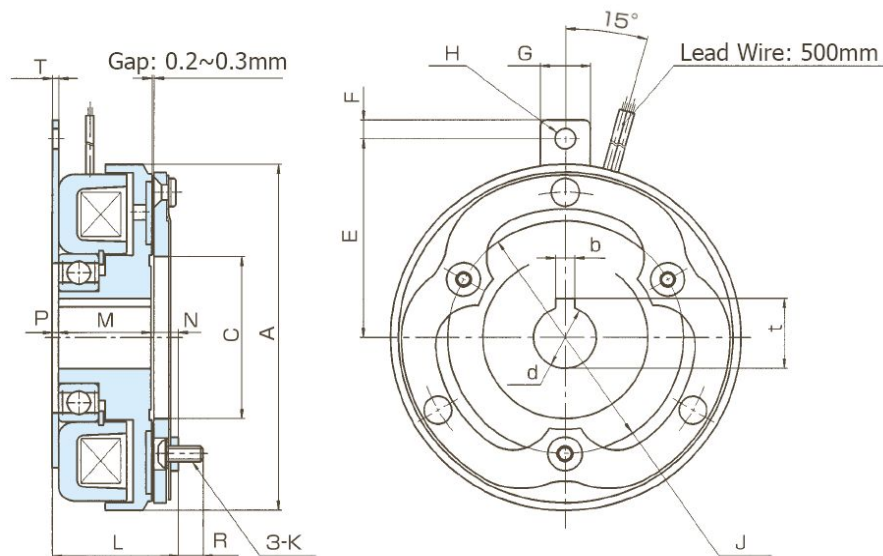

VCE / VCS Type		[ Special ] 0.6		[ Special ] 1.2		[ Special ] 2.5		[ Special ] 5		[ Special ] 10		[ Special ] 20	
		VCE	VCS <sup>1</sup>	VCE	VCS <sup>1</sup>	VCE	VCS <sup>1</sup>	VCE	VCS <sup>1</sup>	VCE	VCS <sup>1</sup>	VCE	VCS <sup>1</sup>
Static Torque [ft-lbs / N-m]		4.4 / 6		8.9 / 12		18 / 25		37 / 50		74 / 100		148 / 200	
Coil (20°C)	Voltage [DC-V]	24											
	Current [A]	0.5		0.65		0.92		1.41		1.6		2.2	
	Resistance [Ω]	48		37		26		17		15		10.9	
	Wattage [W]	12		15		22		33		38		53	
Armature	Pull-In Time [ms]	20		20		30		45		90		110	
	Release Time [ms]	20		30		50		70		85		95	
Torque Build-Up Time [ms]		50		50		70		85		130		155	
Max Allowable Speed [rpm]		7000		6000		5500		4500		3600		3000	
Moment of Inertia (J) [kg-cm <sup>2</sup> ]	Rotor	0.9	1	2.6	2.9	8.1	9.1	24.1	27	58	182		
	Armature	0.5	0.5	1.5	1.6	4.8	5.1	14.3	15.1	45	136		
Max Air Gap Until Adjustment [mm]		0.5		0.6		0.7		0.8		1.2		1.5	
Total Energy Until Adjustment [J]		2.9 x 10 <sup>7</sup>		6.6 x 10 <sup>7</sup>		13 x 10 <sup>7</sup>		26 x 10 <sup>7</sup>		62 x 10 <sup>7</sup>		120 x 10 <sup>7</sup>	
Total Energy Until Life [J]		13 x 10 <sup>7</sup>		25 x 10 <sup>7</sup>		49 x 10 <sup>7</sup>		88 x 10 <sup>7</sup>		170 x 10 <sup>7</sup>		320 x 10 <sup>7</sup>	
Bore [mm]	dH7	12		15		20		25		30		40	
Key Way [mm]	bJs9	4		5		6		8		8		12	
	t	13.8+0.15/-0		17.3+0.15/-0		22.8+0.15/-0		28.3+0.2/-0		33.3+0.2/0		43.3+0.2/0	
Dimensions [mm]	A	70		90		113		142		178		225	
	C	35		45		53		66		83		107	
	E	41		56		65		78		100		125	
	F	5		6		6		6		10		10	
	G	14		16		16		16		24		24	
	H	4.5		5.5		6.5		6.5		8.5		8.5	
	J	46		60		76		95		120		158	
	K	M3		M4		M5		M6		M8		M10	
	L	30	30.5	35.1	35.6	40.5	41.4	45.5	46.5	50.6	60.5		
	M	24		26.5		30		33.5		37.5		44	
	N	5.5	6	6.6	7.1	8.5	9.4	10	11	13.1	16.5		
	P	0.5		2		2		2		0		0	
	R	5.8	5.4	7	6.6	8.2	7.6	10.4	9.6	14	17.5		
T	1.6		2		2		2		2.9		2.9		
Weight [lbs / kg]		1.2 / 0.5		2.2 / 0.1		4.2 / 1.9		7.1 / 3.2		12.8 / 5.8		23.8 / 10.8	

[ Included parts & accessories : bolts, washers, spacers, shims, surge protector ]

[ 1 inch = 25.4 mm ]

[ Note 1 : Silent type ]

# VCEH / VCSH

## EM Clutch (high torque design)

Types: 0.6, 1.2, 2.5, 5

[ EM: Electromagnet ]

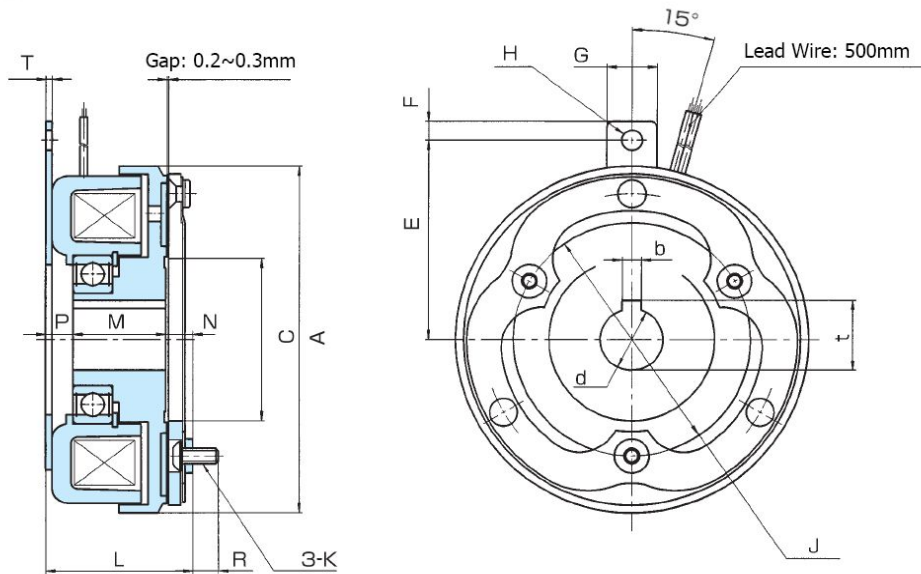

[ Special Order ]

VCEH / VCSH		0.6		1.2		2.5		5	
Type		VCEH	VCSH <sup>1</sup>	VCEH	VCSH <sup>1</sup>	VCEH	VCSH <sup>1</sup>	VCEH	VCSH <sup>1</sup>
Static Torque [ft-lbs / N-m]		5.2 / 7		11 / 15		22 / 30		44 / 60	
Coil (20°C)	Voltage [DC-V]	24							
	Current [A]	0.59		0.69		1.04		1.41	
	Resistance [Ω]	41		35		23		17	
	Wattage [W]	14		17		25		33	
Armature	Pull-In Time [ms]	15		15		25		40	
	Release Time [ms]	25		35		55		75	
Torque Build-Up Time [ms]		45		45		65		80	
Max Allowable Speed [rpm]		7000		6000		5500		4500	
Moment of Inertia (J) [kg-cm <sup>2</sup> ]	Rotor	0.9	1	2.6	2.9	8.1	9.1	24.1	27
	Armature	0.5	0.5	1.5	1.6	4.8	5.1	14.3	15.1
Max Air Gap Until Adjustment [mm]		0.5		0.6		0.7		0.8	
Total Energy Until Adjustment [J]		2.9 × 10 <sup>7</sup>		6.6 × 10 <sup>7</sup>		13 × 10 <sup>7</sup>		26 × 10 <sup>7</sup>	
Total Energy Until Life [J]		13 × 10 <sup>7</sup>		25 × 10 <sup>7</sup>		49 × 10 <sup>7</sup>		88 × 10 <sup>7</sup>	
Bore [mm]	dH7	12		15		20		25	
Key Way [mm]	bJs9	4		5		6		8	
	t	13.8+0.15/-0		17.3+0.15/-0		22.8+0.15/-0		28.3+0.2/-0	
Dimensions [mm]	A	70		90		113		142	
	C	35		45		53		66	
	E	41		56		65		78	
	F	5		6		6		6	
	G	14		16		16		16	
	H	4.5		5.5		6.5		6.5	
	J	46		60		76		95	
	K	M3		M4		M5		M6	
	L	37	37.5	41.1	41.6	47	47.9	50	51
	M	24		26.5		30		33.5	
	N	5.5	6	6.6	7.1	8.5	9.4	10	11
	P	7.5		8		8.5		6.5	
	R	5.8	5.4	7	6.6	8.2	7.6	10.4	9.6
T	1.6		2		2		2		
Weight [lbs / kg]		1.3 / 0.6		2.4 / 1.1		4.9 / 2.2		7.9 / 3.6	

[ Included parts & accessories : bolts, washers, spacers, shims, surge protector ]

[ 1 inch = 25.4 mm ]

[ Note 1 : Silent type ]



# VCEHA / VCSHA

# Self-Adjusting EM Clutch

Types: 1.2, 2.5, 5

[ EM: Electromagnet ]

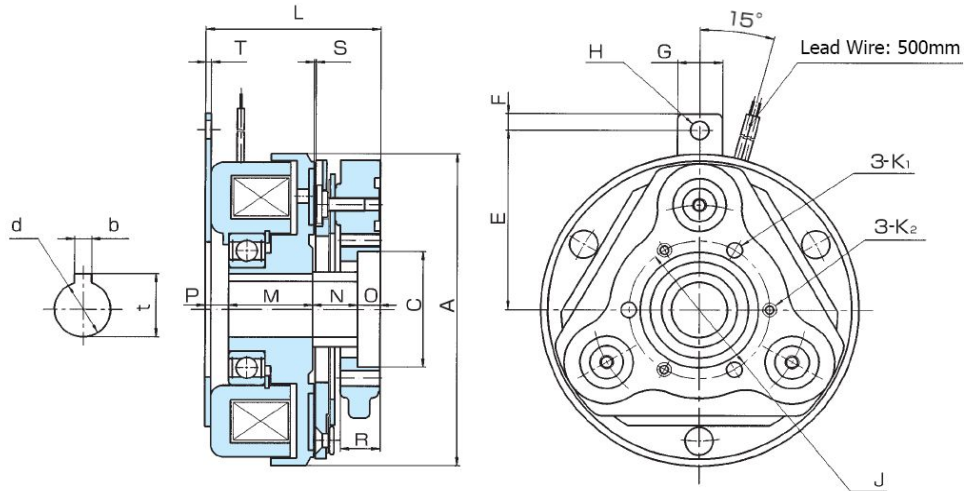

VCEHA / VCSHA		[ Special ] 1.2		[ Special ] 2.5		[ Special ] 5	
Type		VCEHA	VCSHA <sup>1</sup>	VCEHA	VCSHA <sup>1</sup>	VCEHA	VCSHA <sup>1</sup>
Static Torque [ft-lbs / N-m]		8.9 / 12		18 / 25		37 / 50	
Coil (20°C)	Voltage [DC-V]			24			
	Current [A]	0.69		1.04		1.41	
	Resistance [Ω]	35		23		17	
	Wattage [W]	17		25		33	
Armature	Pull-In Time [ms]	30		40		70	
	Release Time [ms]	40		60		70	
Torque Build-Up Time [ms]		60		80		120	
Max Allowable Speed [rpm]		5500		5000		4000	
Moment of Inertia (J) [kg-cm <sup>2</sup> ]	Rotor	2.6	2.9	8.1	9.1	24.1	27
	Armature	4.5	4.5	11.5	11.5	34.7	34.7
Total Energy Until Life [J]		13 x 10 <sup>7</sup>		25 x 10 <sup>7</sup>		49 x 10 <sup>7</sup>	
Bore [mm]	dH7	15		20		25	
Key Way [mm]	bJs9	5		6		8	
	t	17.3+0.15/-0		22.8+0.15/-0		28.3+0.2/-0	
	A	90		113		142	
Dimensions [mm]	CH7	32		42		52	
	E	56		65		78	
	F	6		6		6	
	G	16		16		16	
	H	5.5		6.5		6.5	
	J	40		50		62	
	K1	4.5		5.5		6.6	
	K2	M4		M5		M6	
	L	57	58	62.5	63.5	72	73
	M	26.5		30		33.5	
	N	16.5	17.5	16	17	22	23
	O	6		8		10	
	P	8		8.5		6.5	
	R	13.5		14		20	
	S	0.4		0.4		0.5	
	T	2		2		2	
Recommended Hub Bearing		6002ZZ		6004ZZ		6205ZZ	
Weight [lbs / kg]		3.1 / 1.4		5.7 / 2.6		10 / 4.5	

[ Included parts & accessories : surge protector ]

[ 1 inch = 25.4 mm ]

[ Note 1 : Silent type ]

# VCEH-P / VCSH-P

## EM Clutch (one piece high torque design)

Types: 1.2, 2.5, 5

[ EM: Electromagnet ]

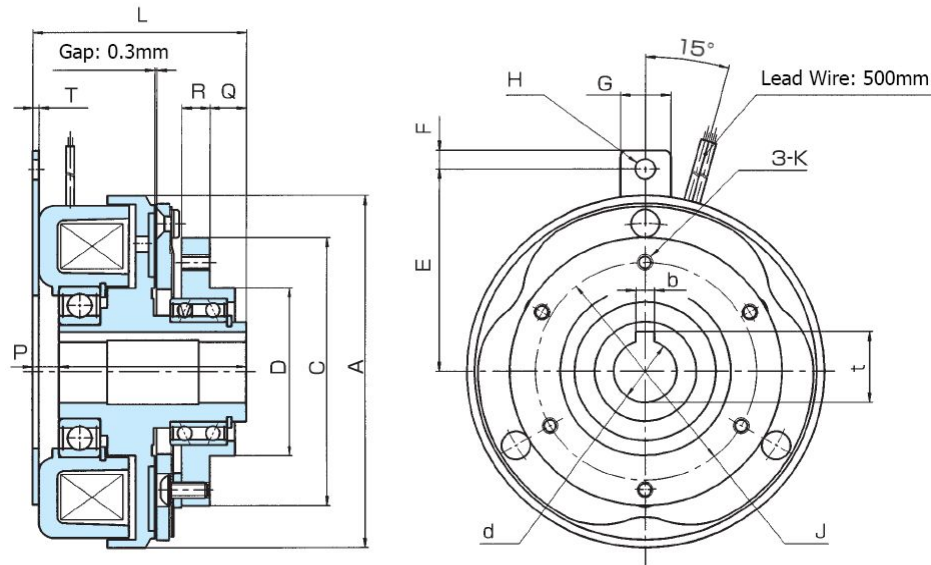

[ Special Order ]

VCEH-P / VCSH-P		1.2P		2.5P		5P	
Type		VCEH	VCSH <sup>1</sup>	VCEH	VCSH <sup>1</sup>	VCEH	VCSH <sup>1</sup>
Static Torque [ft-lbs / N-m]		11 / 15		22 / 30		44 / 60	
Coil (20°C)	Voltage [DC-V]	24					
	Current [A]	0.69		1.04		1.41	
	Resistance [Ω]	35		23		17	
	Wattage [W]	17		25		33	
Armature	Pull-In Time [ms]	15		25		40	
	Release Time [ms]	35		55		75	
Torque Build-Up Time [ms]		45		65		80	
Max Allowable Speed [rpm]		6000		5500		4500	
Moment of Inertia (J) [kg-cm <sup>2</sup> ]	Rotor	3	3.3	8.4	9.4	25.4	28.2
	Armature	3.8	3.9	8.6	9	26	26.8
Total Energy Until Life [J]		13 x 10 <sup>7</sup>		25 x 10 <sup>7</sup>		49 x 10 <sup>7</sup>	
Bore [mm]	dH7	15		20		25	
Key Way [mm]	bJs9	5		6		8	
	t	17.3+0.15/-0		22.8+0.15/-0		28.3+0.2/-0	
Dimensions [mm]	A	90		113		142	
	Ch8	76		86		106	
	Dh8	54		54		72	
	E	56		65		78	
	F	6		6		6	
	G	16		16		16	
	H	5.5		6.5		6.5	
	J	66		70		90	
	K	M4		M5		M6	
	L	64		67.5		76.5	
	M	56		59		70	
	P	8		8.5		6.5	
	Q	15	14.5	11.5	10.6	15.5	14.5
R	7.9		9		11		
T	2		2		2		
Weight [lbs / kg]		3.7 / 1.7		6.2 / 2.8		11 / 5	

[ Included parts & accessories : surge protector ]

[ 1 inch = 25.4 mm ]

[ Note 1 : Silent type ]

# VC: TYPICAL INSTALLATION

## Standard Type

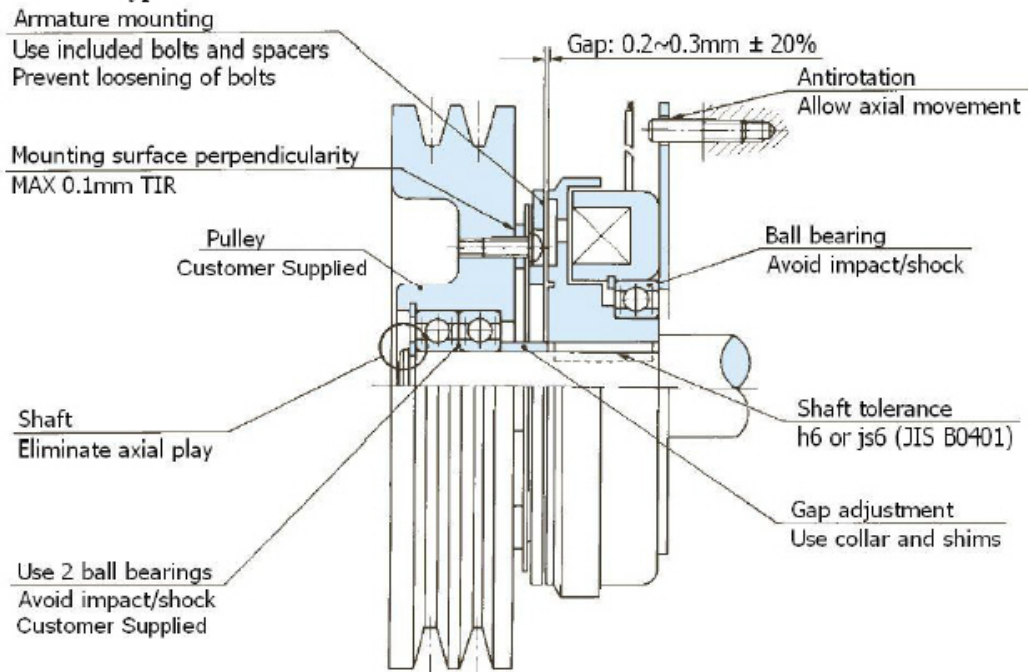

## Auto Adjust Type (output bearings and pulley or sprocket supplied by customer)

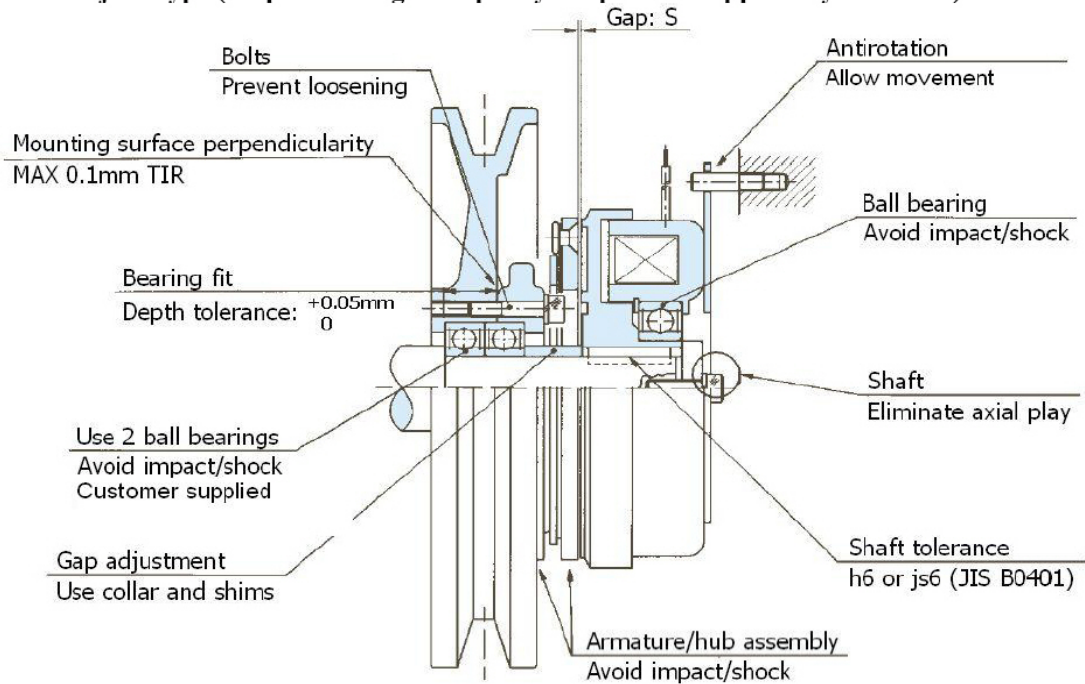



# VC: TORQUE CHARACTERISTIC & MAX WORK RATE

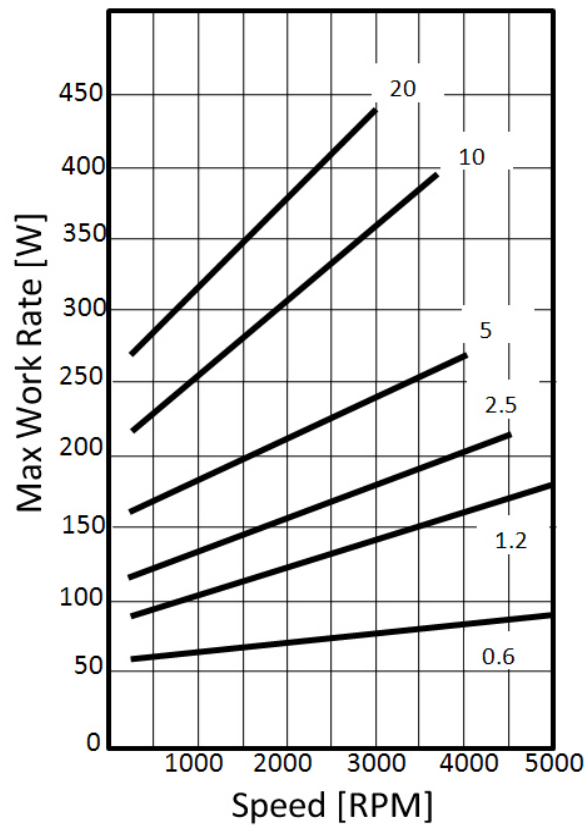
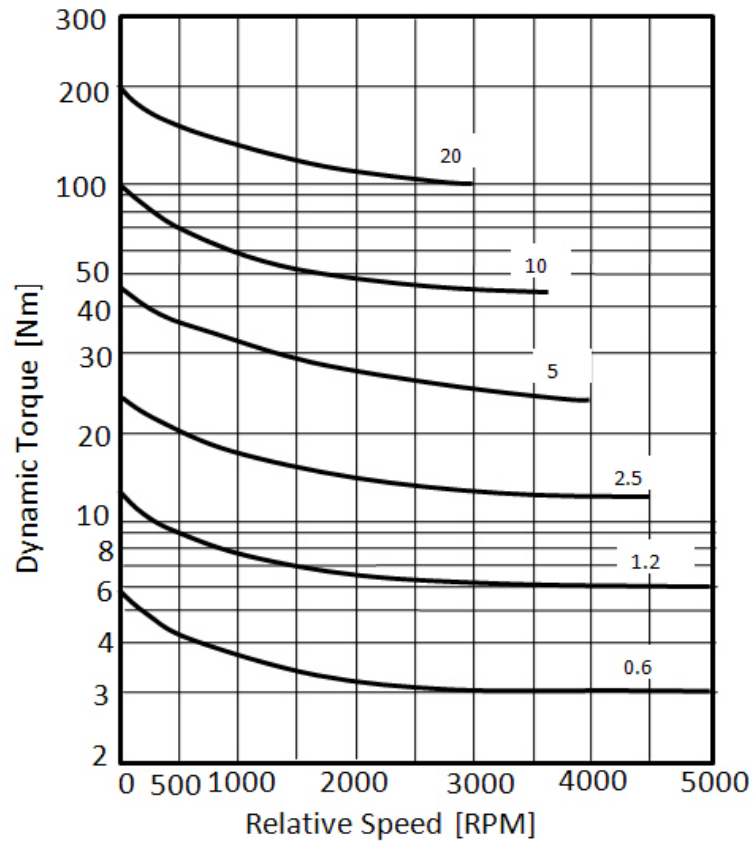



# VF

## Cooling Fan for V-Series Units

Types: 1.2, 2.5, 5

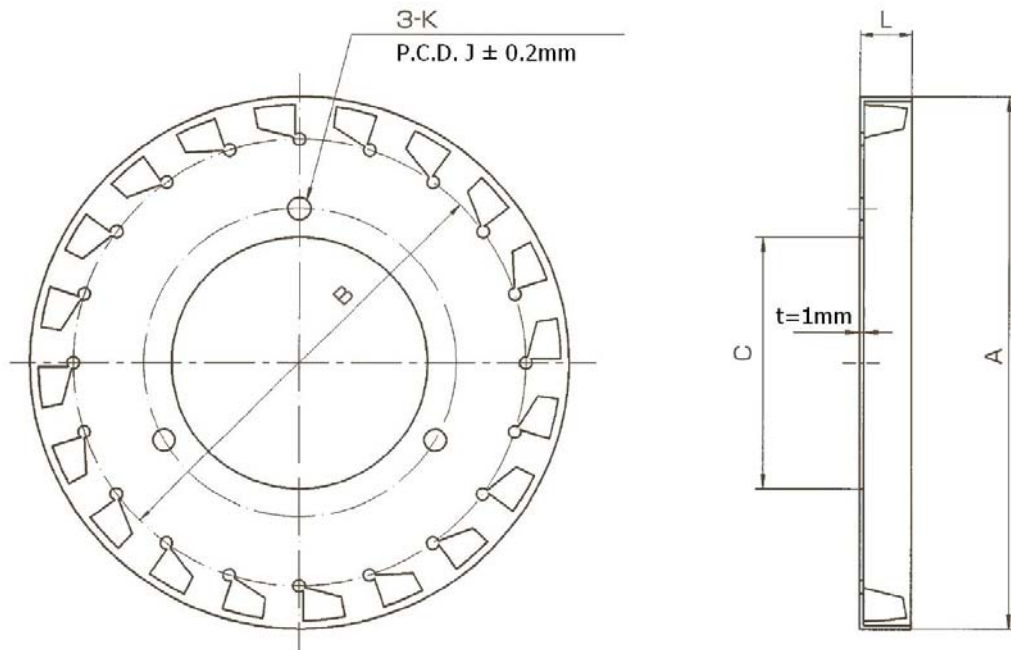

VF		1.2	2.5	5	
Max Allowable Speed [rpm]		2000	2000	2000	
Dimensions [mm]	A	108	131	164	
	B	88	110	138	
	C	50	62	76	
	K	4.5	5.5	6.5	
	J	60	76	95	
	L	11	13	16	
Applicable Units		VCE(H)	VCS(H)	VBE(H)	VBS(H)
Optional Units <sup>1</sup>		VCE(H)-P	VCS(H)-P	VCEHA	VCSHA
		VBE(H)-P	VBS(H)-P	VBEHA	VBSHA

[ Note 1 : Available as factory-mounted only ]

[ 1 inch = 25.4 mm ]

# CT

## S E R I E S

### SELF-ADJUSTING ELECTROMAGNETIC CLUTCH

Torque Range: 20 ~ 50 ft-lbs

Torque Range: 27 ~ 68 N-m

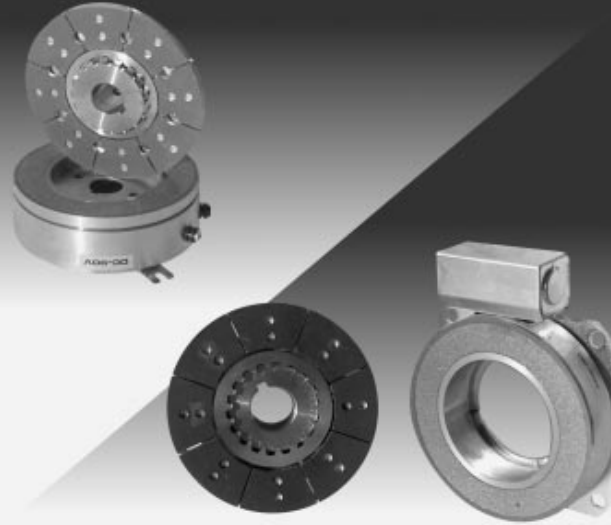

## FEATURES

### AUTOMATIC ADJUSTMENT FOR WEAR

The CT clutches include a patented adjusting mechanism for the armature that not only gives a constant adjustment for wear, but also produces a constant air gap on return. This gives a consistent armature engagement time over the life of the unit which is critical in some cycling applications.

### SMOOTH, QUIET OPERATION

Chattering noise between armature and hub spline is eliminated due to patented armature design which includes a rubber dampener to produce smooth, quiet operation.

### STAINLESS STEEL HUB

Stainless steel hubs break up residual magnetism (flux) at the hub, preventing the magnetism from being transmitted into the shaft. Stainless steel also has superior corrosion resistance which helps eliminate potential corrosion between the armature and the hub.

### HEAVY DUTY STANDARD DESIGN

Armature to hub connection is via heavy duty spline.

### EXCELLENT HEAT DISSIPATION

The design of flutes in the armature helps to dissipate the heat generated by friction on engagement.



CT

# CT

# Self-Adjusting EM Clutch

Types: 20, 50

[ EM: Electromagnet ]

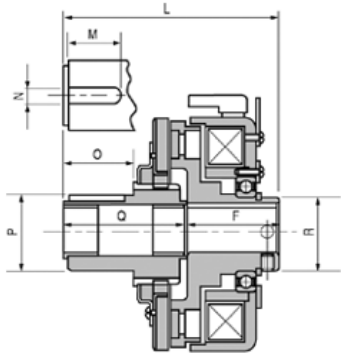

Extended Hub (model 20 only)

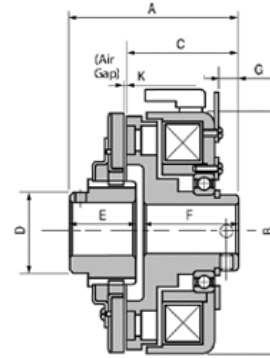
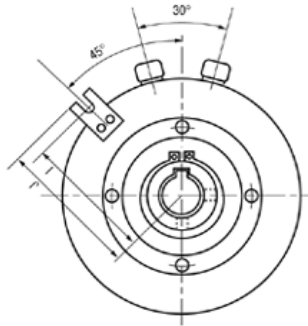

Standard Hub

CT		20	50
Rated Torque [ft-lbs / N-m]		20 / 27.1	50 / 67.8
Coil (20°C)	Voltage [DC-V]	90 <sup>1</sup> , 28, 24 <sup>1</sup> , 6	90 <sup>1</sup> , 24 <sup>1</sup> , 6
	Resistance [Ω]	1087, 105, 74, 4.8	237, 16, 1.1
Max Allowable Speed [rpm]		4500	4000
Standard Bore Options [in]	Bore	1/2	1-1/8
	Key Way	1/8 x 1/16	1/4 x 1/2
	Bore	5/8	1-1/4
	Key Way	3/16 x 3/32	1/4 x 1/8
	Bore	3/4	Accepts Type G Bushing
Key Way	3/16 x 3/32		
Bore	7/8 <sup>2</sup>		
Dimensions [in]	Key Way	3/16 x 3/32	
	Bore	1 <sup>2</sup>	
	Key Way	1/4 x 1/8	
	A	2.938	3.219
	B	4.5	5.313
	C	1.938	2.094
	D	1.564	1.969
	E	1.188	1.313
	F	1.625	1.5
	G	0.375	0.375
	I	2.25	2.875
	J	2.5	3.125
	K	0.024	0.031
	L	3.813	-
	M	1	-
	N	0.3125 / 0.3145	-
	O	1.125	-
P	1.375 / 1.376	-	
Q	2.188	-	
R	1.594	-	
Weight [lbs / kg]		9.2 / 4.2	15 / 7

[ Note 1 : Most common voltage ]

[ 1" = 25.4mm ]

[ Note 2 : Not available with extended hubs ]

# TMC

S E R I E S

## ELECTROMAGNETIC CLUTCH [ZERO BACKLASH]

Torque Range: 4.4 ~ 148 ft-lbs

Torque Range: 6 ~ 200 N-m

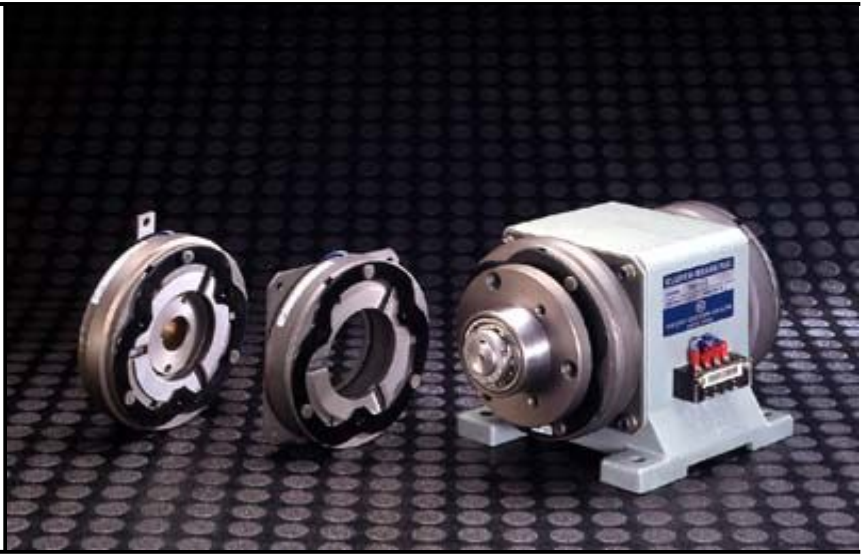

## FEATURES

### FAST RESPONSE

TM series clutches are dry type single disc units with no sliding parts. That means you can count on fast response time.

### NO BACKLASH ARMATURE

By mounting the armature to its hub by means of leaf springs, backlash is minimized and armature rattle is eliminated.

### COMPACT DESIGN

The compact design of the TM series reduces mounting requirements and makes installation a snap.

### MOUNTING FLEXIBILITY

The TM series can be provided with a flange mount or bearing mount design.

### LOW INERTIA

Fast response and low inertia are due to the TM series low weight and compact design.

TM CLUTCHES HAVE BEEN REPLACED BY THE V SERIES, ALTHOUGH SOME TM SERIES MAY STILL BE AVAILABLE  
PLEASE CHECK FOR AVAILABILITY



Model TMC clutch



Model TMF clutch

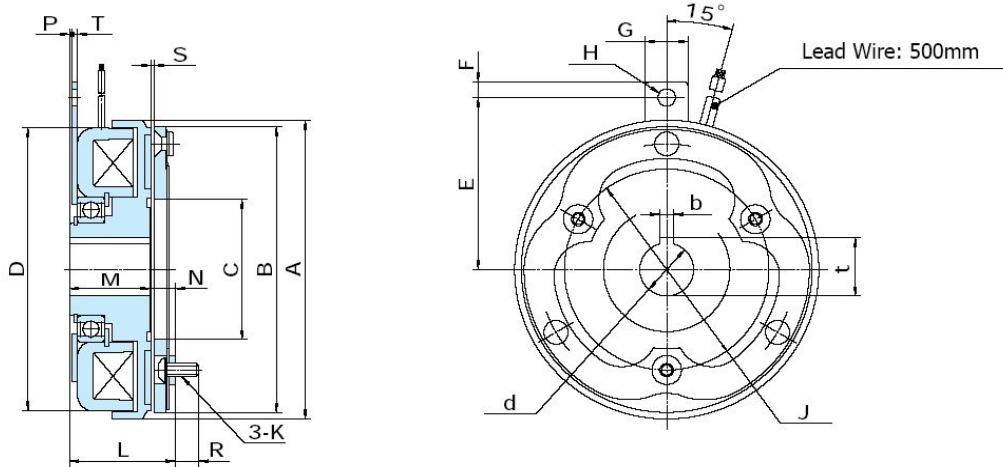

[ Special Order ]

TMC		0.6	1.2	2.5	5	10	20
Static Torque [ft-lbs / N-m]		4.4 / 6	8.9 / 12	18 / 24	37 / 50	74 / 100	148 / 200
Coil (20°C)	Voltage [DC-V]	24					
	Current [A]	0.5	0.65	0.92	1.35	1.6	2.2
	Resistance [Ω]	48	37	26	18	15	11
	Wattage [W]	12	15	22	33	38	53
Armature	Pull-In Time [ms]	15	21	30	52	90	110
	Release Time [ms]	18	21	32	48	85	95
Torque Build-Up Time [ms]		47	52	76	87	130	155
Max Allowable Speed [rpm]		5000	5000	4500	4000	3600	3000
Moment of Inertia (J) [kg-cm <sup>2</sup> ]	Rotor	0.75	2.3	7.3	23	58	194
	Armature	0.5	1.5	4.8	14	45	136
Max Air Gap Until Adjustment [mm]		0.5	0.6	0.7	0.8	1.2	1.5
Total Energy Until Adjustment [J]		2.9 x 10 <sup>7</sup>	6.6 x 10 <sup>7</sup>	13 x 10 <sup>7</sup>	26 x 10 <sup>7</sup>	62 x 10 <sup>7</sup>	120 x 10 <sup>7</sup>
Total Energy Until Life [J]		13 x 10 <sup>7</sup>	25 x 10 <sup>7</sup>	49 x 10 <sup>7</sup>	88 x 10 <sup>7</sup>	170 x 10 <sup>7</sup>	320 x 10 <sup>7</sup>
Bore [mm]	dH7	12	15	20	25	30	40
Key Way [mm]	bE9	4	5	5	7	7	10
	t+0.15/-0	13.5	17	22	28	33	43.5
Dimensions [mm]	A	70	90	113	142	178	225
	B	67	86	108	136	170	215
	C	35	45	53	66	83	107
	D	66	85	107	135	169	214
	E	41	56	65	78	100	125
	F	5	6	6	6	10	10
	G	14	16	16	16	24	24
	H	4.5	5.5	6.5	6.5	8.5	8.5
	J	46	60	76	95	120	158
	K	M3	M4	M5	M6	M8	M10
	L	29.5	33.1	38.5	43.5	50.6	60.5
	M	24	26.5	30	33.5	37.5	44
	N	5.5	6.6	8.5	10	13.1	16.5
	P	1	1	1	1	0.1	0
R	5.8	7	8.2	10.4	14	17.5	
S	0.2~0.3	0.2~0.3	0.2~0.3	0.2~0.3	0.3~0.4	0.4~0.5	
T	1.6	2	2	2	2.9	2.9	
Weight [lbs / kg]		1.1 / 0.5	2.2 / 1.0	4.0 / 1.8	7.3 / 3.3	13 / 6	24 / 11



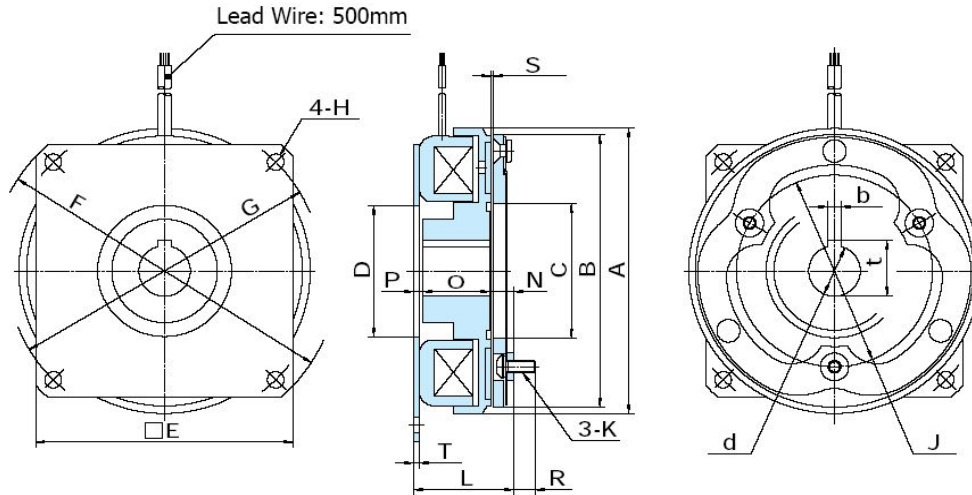

[ Special Order ]

TMF		0.6	1.2	2.5	5	10	20
Static Torque [ft-lbs / N-m]		4.4 / 6	8.9 / 12	18 / 24	37 / 50	74 / 100	148 / 200
Coil (20°C)	Voltage [DC-V]	24					
	Current [A]	0.5	0.65	0.92	1.35	1.6	2.2
	Resistance [Ω]	48	37	26	18	15	11
	Wattage [W]	12	15	22	33	38	53
Armature	Pull-In Time [ms]	15	21	30	52	90	110
	Release Time [ms]	18	21	31	48	85	95
Torque Build-Up Time [ms]		47	52	76	87	130	155
Max Allowable Speed [rpm]		5000	5000	4500	4000	3600	3000
Moment of Inertia (J) [kg-cm <sup>2</sup> ]	Rotor	0.75	2.3	7.3	23	58	194
	Armature	0.5	1.5	4.8	14	45	136
Max Air Gap Until Adjustment [mm]		0.5	0.6	0.7	0.8	1.2	1.5
Total Energy Until Adjustment [J]		2.9 x 10 <sup>7</sup>	6.6 x 10 <sup>7</sup>	13 x 10 <sup>7</sup>	26 x 10 <sup>7</sup>	62 x 10 <sup>7</sup>	120 x 10 <sup>7</sup>
Total Energy Until Life [J]		13 x 10 <sup>7</sup>	25 x 10 <sup>7</sup>	49 x 10 <sup>7</sup>	88 x 10 <sup>7</sup>	170 x 10 <sup>7</sup>	320 x 10 <sup>7</sup>
Bore [mm]	dH7	12	15	20	25	30	40
Key Way [mm]	bE9	4	5	5	7	7	10
	t+0.15/-0	13.5	17	22	28	33	43.5
Dimensions [mm]	A	70	90	113	142	178	225
	B	67	86	108	136	170	215
	C	35	45	53	66	83	107
	DH8	35	45	52	65	80	100
	E	62	82	100	125	156	200
	Fh8	85	110	135	165	210	265
	G	75	98	122	150	190	240
	H	4.5	5.5	6.5	6.5	8.5	11
	J	46	60	76	95	120	158
	K	M3	M4	M5	M6	M8	M10
	L	28.9	32.4	38	43	50.6	60.5
	N	5.5	6.6	8.5	10	13.1	16.5
	O	20	22	26	29	33	42
	P	3.4	3.8	3.5	4	4.5	2
	R	5.8	7	8.2	10.4	14	17.5
S	0.2~0.3	0.2~0.3	0.2~0.3	0.2~0.3	0.3~0.4	0.4~0.5	
T	2	2.3	2.6	2.6	2.9	3.2	
Weight [lbs / kg]		1.1 / 0.5	2.2 / 1.0	3.7 / 1.7	6.6 / 3.0	13 / 6	25 / 11

# TMC & TMF: TYPICAL INSTALLATION

TMC Clutch

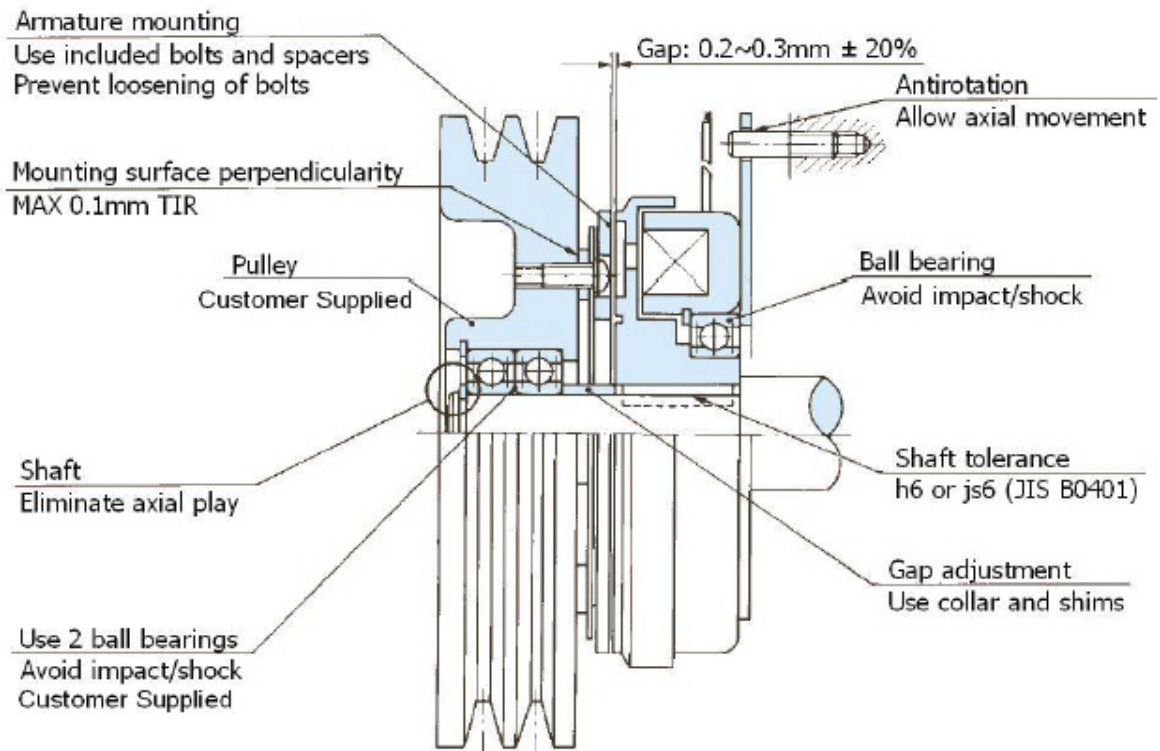

TMF Clutch

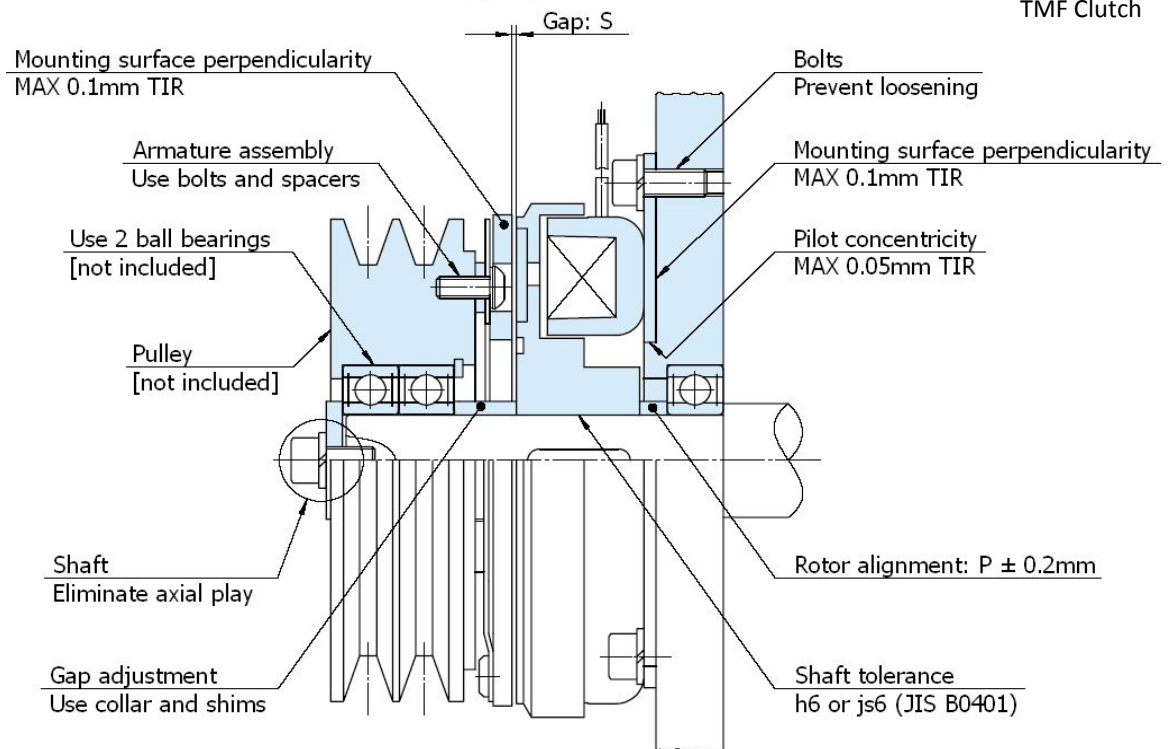

# TMC & TMF: TORQUE CHARACTERISTIC & MAX WORK RATE

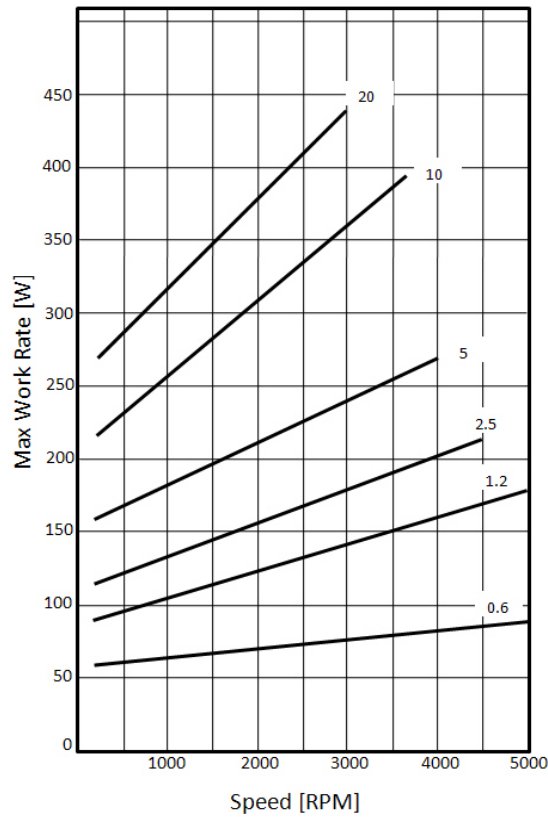
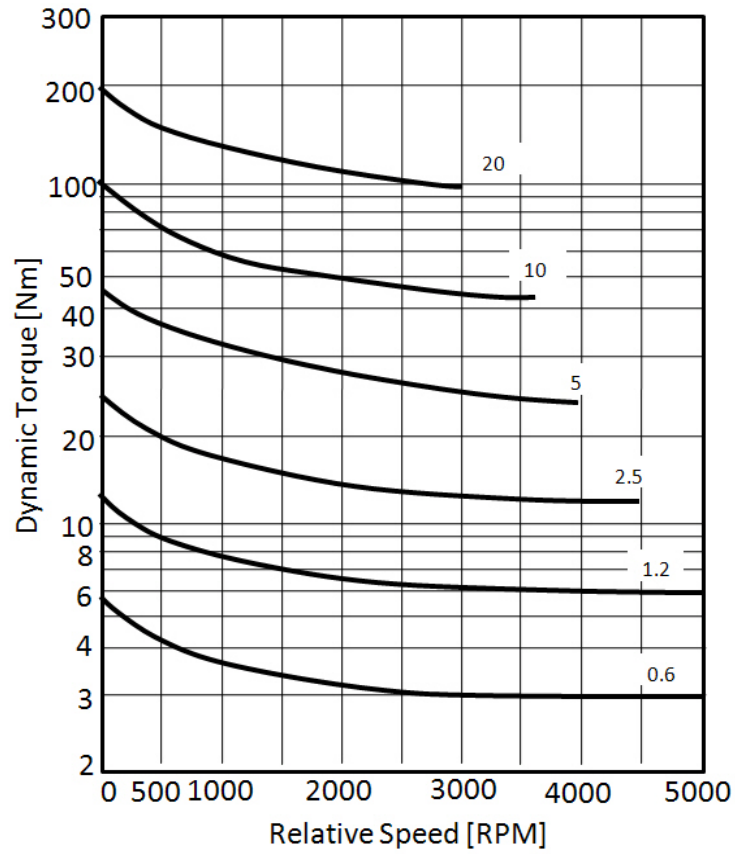

# MMC

S E R I E S

## ELECTROMAGNETIC CLUTCH

Torque Range: 37 ~ 1475 ft-lbs

Torque Range: 50 ~ 2000 N-m



## FEATURES

### HEAVY DUTY DESIGN

The MMC series utilize a special plate spring that resists engine vibration and shock.

### EASY MOUNTING

Mounting is a snap on these stationary coil type clutches. The coil is supported by a ball bearing. Alignment and maintenance are not required.

### ROTATION FLEXIBILITY

Rotation may be clockwise or counterclockwise.

### LONGEVITY

Efficient heat dissipation allows long life even in heavy duty applications. Clutch surface is tempered to provide effective rust protection.

### COMPACT AND HIGH TORQUE

The compact design of the MMC series requires minimal space while providing high torque.



MMC

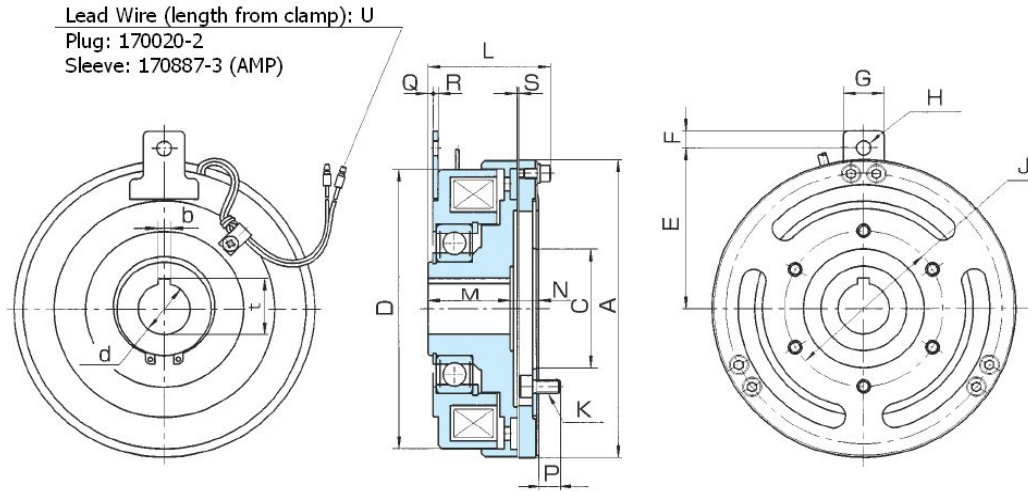

MMC		5E	5G	10E	10G	20E	20G	40E	40G
Static Torque [ft-lbs / N-m]		37 / 50		74 / 100		148 / 200		295 / 400	
Coil (20°C)	Voltage [DC-V]	12	24	12	24	12	24	12	24
	Current [A]	2.5	1.26	2.92	1.46	4.17	2.09	5.41	2.7
	Resistance [Ω]	4.8	19	4.11	16.4	2.88	11.5	2.22	8.9
	Wattage [W]	30		35		50		65	
Armature	Pull-In Time [ms]	50		70		80		120	
	Release Time [ms]	90		150		140		160	
Max Allowable Speed [rpm]		4000		3600		3000		3000	
Moment of Inertia (J) [kg-cm <sup>2</sup> ]	Rotor	22		73		221		550	
	Armature	18		59		143		380	
Max Air Gap Until Adjustment [mm]		1.3		1.3		1.3		1.3	
Total Energy Until Adjustment [J]		13 x 10 <sup>7</sup>		20 x 10 <sup>7</sup>		28 x 10 <sup>7</sup>		40 x 10 <sup>7</sup>	
Total Energy Until Life [J]		33 x 10 <sup>7</sup>		50 x 10 <sup>7</sup>		71 x 10 <sup>7</sup>		100 x 10 <sup>7</sup>	
Bore [mm]	dH7	25		30		40		50	
Key Way [mm]	bE9	7		7		10		15	
	t+0.25/-0	28		33		43.5		55	
Dimensions [mm]	A	141		176		221		261	
	CH9	52		70		92		115	
	D	133		165		207.2		243	
	E	80		95		120		140	
	F	6		10		10		12	
	G	16		24		24		28	
	H	5.5		8.5		8.5		10.5	
	J	70		92		118		142	
	K	6xM6-12		6xM8-16		6xM10-20		8xM10-20	
	L	56.1		71.3		79.8		90.2	
	M	35		48		53		65	
	N	15.5		16.5		18		16.2	
	P	9.2		12.3		15.3		15.1	
	Q	2		3.1		3.1		6.8	
	R	2		2.9		2.9		3.2	
S	0.3~0.5		0.3~0.5		0.4~0.6		0.5~0.7		
U	400		370		410		380		
Weight [lbs / kg]		7.5 / 3.4		15.0 / 6.8		26.0 / 11.8		43.0 / 19.5	

[ Included parts & accessories : bolts, plug 170021-2, sleeve 170889-2 (AMP), surge protector ]

[ 1" = 25.4mm ]



# MMC

## EM Clutch

Types: 70, 100, 200

[ EM: Electromagnet ]

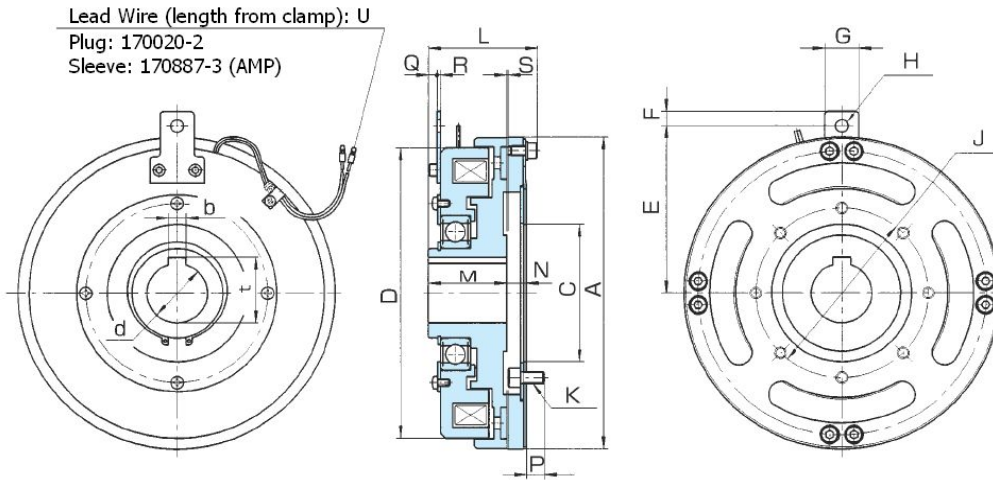

MMC		70E	70G	100E	100G	200G
Static Torque [ft-lbs / N-m]		516 / 700		738 / 1000		1475 / 2000
Coil (20°C)	Voltage [DC-V]	12	24	12	24	24
	Current [A]	7.5	3.75	8.33	4.14	6.15
	Resistance [Ω]	1.6	6.4	1.44	5.8	3.9
	Wattage [W]	90		100		150
Armature	Pull-In Time [ms]	180		200		400
	Release Time [ms]	180		200		400
Max Allowable Speed [rpm]		2500		1800		1600
Moment of Inertia (J) [kg-cm <sup>2</sup> ]	Rotor	1030		2800		6300
	Armature	980		2100		3800
Max Air Gap Until Adjustment [mm]		1.3		1.6		1.6
Total Energy Until Adjustment [J]		58 x 10 <sup>7</sup>		80 x 10 <sup>7</sup>		88 x 10 <sup>7</sup>
Total Energy Until Life [J]		140 x 10 <sup>7</sup>		200 x 10 <sup>7</sup>		220 x 10 <sup>7</sup>
Bore [mm]	dH7	60		70		80
Key Way [mm]	bE9	15		18		20
	t+0.25/-0	65		76		86
Dimensions [mm]	A	316		381		400
	CH9	150		185		185
	D	293		360		375
	E	170		210		220
	F	13		13		13
	G	30		30		40
	H	13		13		13
	J	180		220		220
	K	8xM10-20		8xM12-25		8xM16-30
	L	100.4		111.3		144.1
	M	70		80		102
	N	19		20		28.8
	P	14.8		19.8		26
	Q	2.8		14.8		5
	R	3.2		3.2		5
S	0.6~0.8		0.7~0.9		0.7~0.9	
U	370		340		300	
Weight [lbs / kg]		71 / 32		104 / 47		174 / 79

[ Included parts & accessories : bolts, plug 170021-2, sleeve 170889-2 (AMP), surge protector ]

[ 1" = 25.4mm ]

# MMC: TYPICAL INSTALLATION

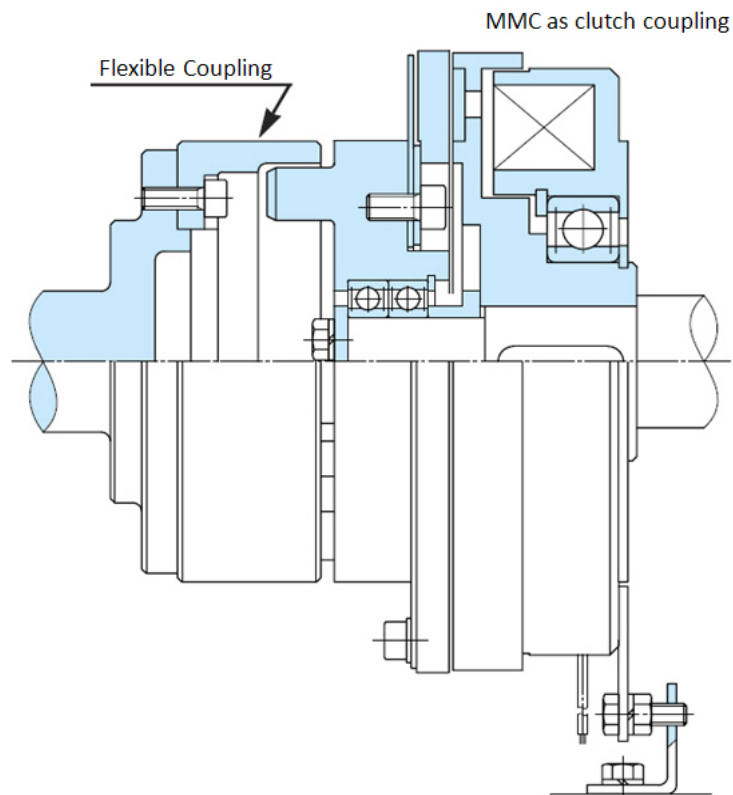
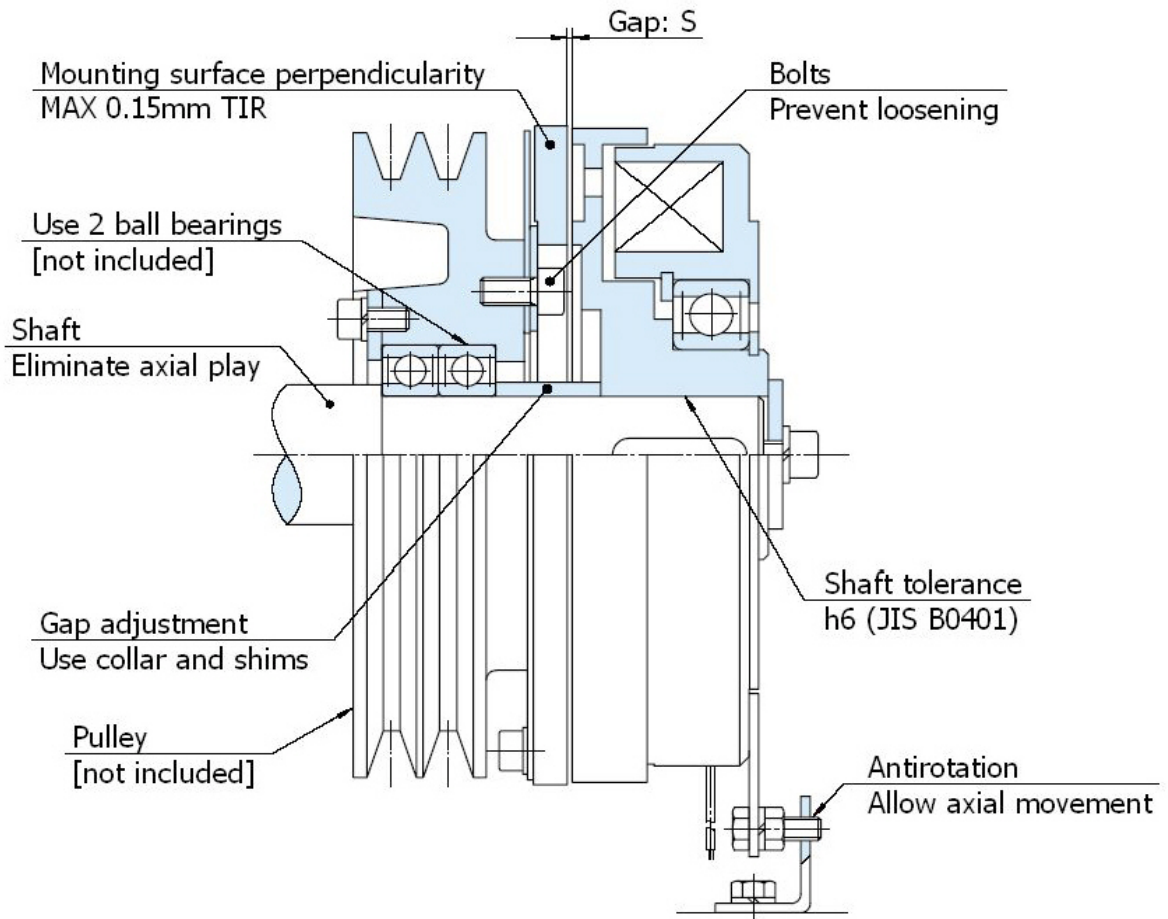

# MMC: TORQUE CHARACTERISTIC & MAX WORK RATE

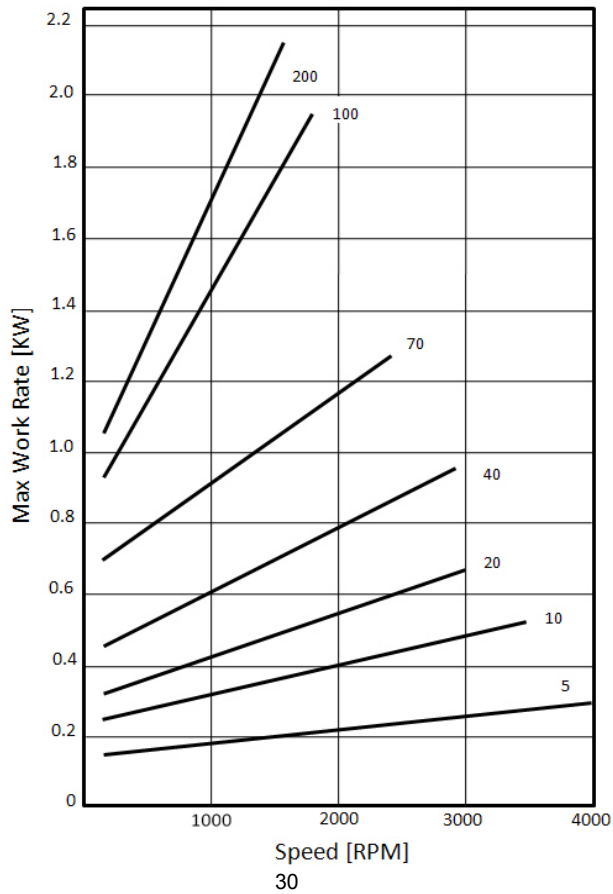
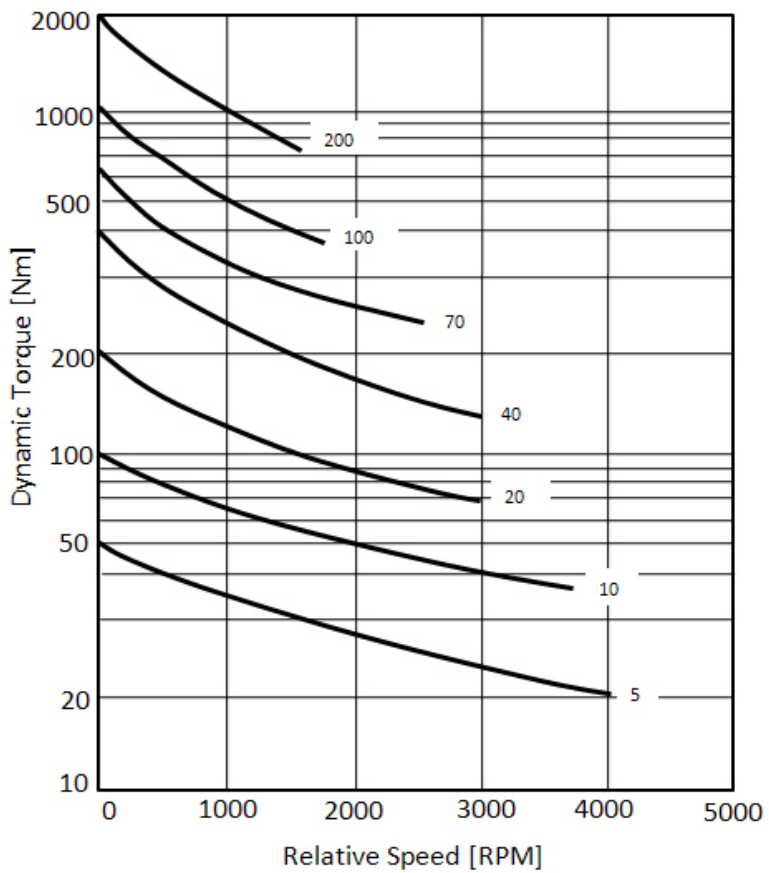

# MD

S E R I E S

## DRY-TYPE MULTIPLE-DISK ELECTROMAGNETIC CLUTCH & BRAKE

Torque Range: 13 ~ 6196 ft-lbs

Torque Range: 18 ~ 8400 N-m



## FEATURES

### HIGH-TORQUE COMPACT DESIGN

The MD series are designed to produce very high torque in an overall compact design. Torque is produced via multiple disks condensing overall clutch size.

### QUICK RELEASE TIME

Separator springs between the friction plates allow for quick disconnect when the power is released. These springs also keep the disks from making contact with each other in the disengaged mode.

### FAST TORQUE BUILD-UP

Because of limited internal movement and via multiple disks, clutch torque can be generated very quickly.

### EASILY CONNECT TO YOUR GEAR, PULLEY OR COUPLING

The MD series is made to be used with the UN drive cup, the cup slides between the friction disk tangs and has a tapped bolt pattern so you can attach your bearing mounted gear pulley.



MDC



MDB-N



UN Drive Cup

# MDC

## Dry-Type Multiple-Disk EM Clutch

Types: 1.2, 2.5, 5, 10, 20

[ EM: Electromagnet ]

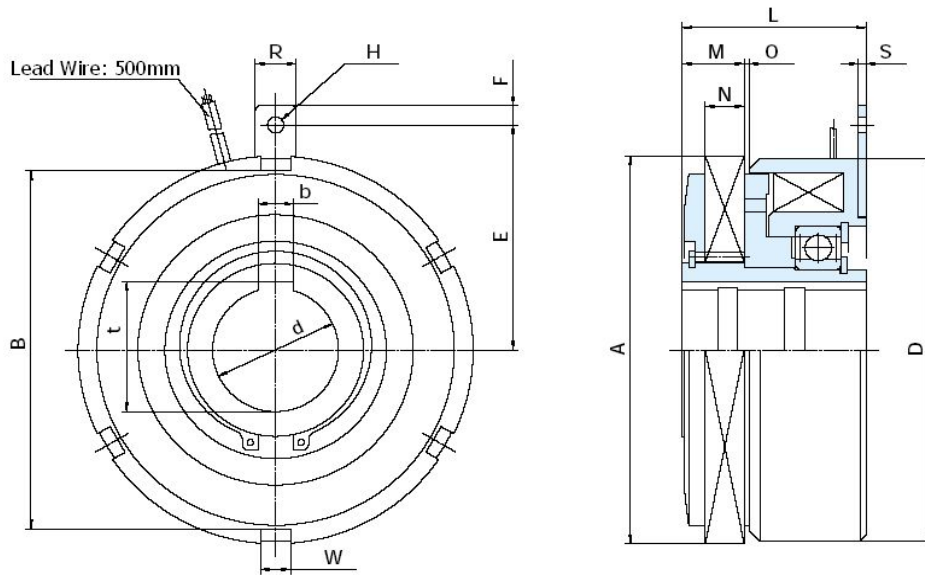

MDC		1.2	2.5	5	10	20
Dynamic Torque [ft-lbs / N-m]		8.9 / 12	18 / 25	37 / 50	74 / 100	148 / 200
Static Torque [ft-lbs / N-m]		13 / 17	26 / 35	52 / 71	103 / 140	207 / 281
Coil (20°C)	Voltage [DC-V]	24				
	Current [A]	0.48	0.71	0.91	1.5	1.9
	Resistance [Ω]	49.5	34	26.4	16	12.8
	Wattage [W]	12	17	22	36	45
Armature Pull-In Time [ms]		36	50	60	80	110
Torque Build-Up Time [ms]		80	130	150	160	240
Torque Decay Time [ms]		34	38	50	63	120
Max Allowable Speed [rpm]		1400	1200	1000	850	700
Moment of Inertia (J) [kg-cm <sup>2</sup> ]	Hub	3	6	14	34	61
	Outer Disc	0.5	1	2	7	13
Total Energy Until Life [J]		2.5 x 10 <sup>7</sup>	3.7 x 10 <sup>7</sup>	5.8 x 10 <sup>7</sup>	12.3 x 10 <sup>7</sup>	16.0 x 10 <sup>7</sup>
Max Work Rate [W]		7	11	23	42	65
Bore [mm]	dH7	20	25	30	40	50
Key Way [mm]	bE9	6	8	8	12	14
	t+0.2/-0	21.7	26.7	32	42.5	52.5
Dimensions [mm]	A	80	95	112	132	157
	B	73	87.5	103	122	145
	D	78	93	110	130	155
	E	47	57	63	80	91
	F	6	6	6	8	8
	H	5.5	5.5	5.5	6.5	6.5
	L	45	49	57	63	73
	M	13.5	14.8	17.7	22	24.5
	N	8.5	9.3	10.2	14.2	15.4
	O	2	2	1.5	2	2
	R	12	14	14	16	16
	S	2	2.3	2.3	3	3
	W	8	10	10	12	12
	W (Qty)	6	6	6	6	6
Weight [lbs / kg]		3.1 / 1.4	4.4 / 2.0	6.6 / 3.0	11 / 5	17 / 8
Coupling		UN1.2	UN2.5	UN5	UN10	UN20

[ Included parts & accessories : surge protector ]

[ 1" = 25.4mm ]



# MDC

## Dry-Type Multiple-Disk EM Clutch

Types: 40, 80, 160, 250, 320, 450, 600

[ EM: Electromagnet ]

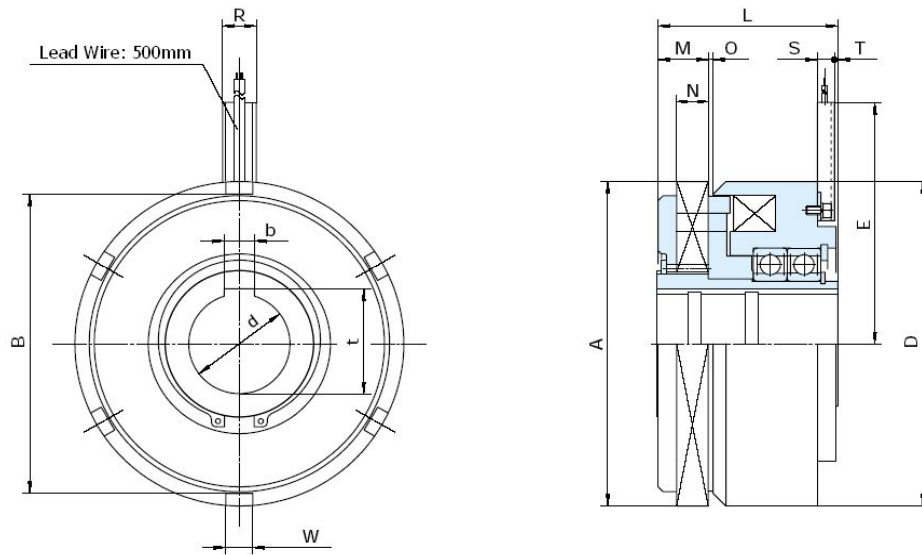

MDC		40	80	160	250	320	450	600	
Dynamic Torque [ft-lbs / N-m]		295 / 400	590 / 800	1180 / 1600	1844 / 2500	2360 / 3200	3319 / 4500	4425 / 6000	
Static Torque [ft-lbs / N-m]		413 / 560	826 / 1120	1652 / 2240	2581 / 3499	3304 / 4480	4647 / 6300	6196 / 8400	
Coil (20°C)	Voltage [DC-V]	24							
	Current [A]	2	2.5	3.7	4.6	5.1	7.3	6.2	
	Resistance [Ω]	12	9.6	6.5	5.2	4.7	3.3	3.9	
	Wattage [W]	50	60	90	110	125	175	150	
Armature Pull-In Time [ms]		140	220	250	320	380	500	750	
Torque Build-Up Time [ms]		290	610	700	810	930	1200	1500	
Torque Decay Time [ms]		150	160	160	200	300	450	650	
Max Allowable Speed [rpm]		550	450	400	350	300	250	200	
Moment of Inertia (J) [kg-cm <sup>2</sup> ]	Hub	249	715	2070	3580	5400	10500	15500	
	Outer Disc	24	97	340	590	930	1700	3800	
Total Energy Until Life [J]		25.0 x 10 <sup>7</sup>	35.0 x 10 <sup>7</sup>	68.3 x 10 <sup>7</sup>	88.3 x 10 <sup>7</sup>	100.0 x 10 <sup>7</sup>	141.7 x 10 <sup>7</sup>	160.0 x 10 <sup>7</sup>	
Max Work Rate [W]		97	153	283	450	633	933	1417	
Bore [mm]	dH7	60	70	90	100	110	120	140	
Key Way [mm]	bE9	18	20	25	28	28	32	35	
	t+0.2/-0	63	75	95	106.5	119	130	151	
	A	195	235	290	325	350	400	440	
Dimensions [mm]	B	180	218	265	300	320	363.5	400	
	D	195	235	290	324	350	392	428	
	E	145	160	200	220	230	250	270	
	L	107	135	170	185	210	220	255	
	M	30.2	40	49	55	59.7	63	80	
	N	18.7	23	30.8	33.5	37.7	36.3	53	
	O	3	4	5	5	10.1	10	10	
	R	20	20	25	30	30	30	30	
	S	10	10	18	15	15	15	15	
	T	2	4	5	11	10	17	17	
	W	16	22	30	40	40	50	50	
	W (Qty)		6	6	6	6	6	6	8
	Weight [lbs / kg]		37 / 17	71 / 32	123 / 56	174 / 79	229 / 104	309 / 140	423 / 192
	Coupling		UN40	UN80	UN160	UN250	UN320	UN450	UN600

[ Included parts & accessories : surge protector ]

[ 1" = 25.4mm ]

# MDC: TYPICAL INSTALLATION

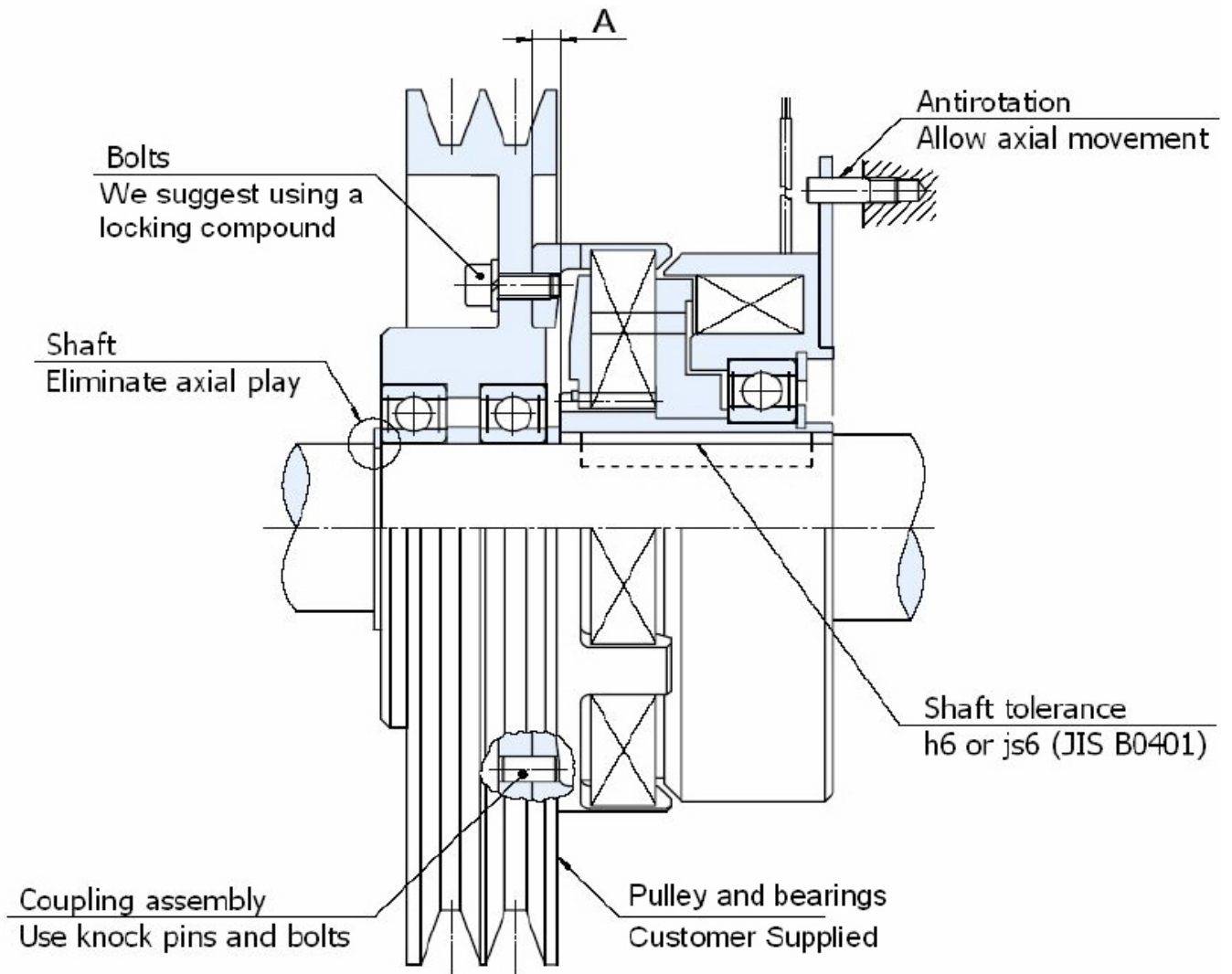

MDC	1.2	2.5	5	10	20	40
Dimension A [mm]	5.5	5.5	6	6.5	9.5	14
MDC	80	160	250	320	450	600
Dimension A [mm]	17	23	25	30	36	36

# MDC: MAX ENGAGEMENT ENERGY

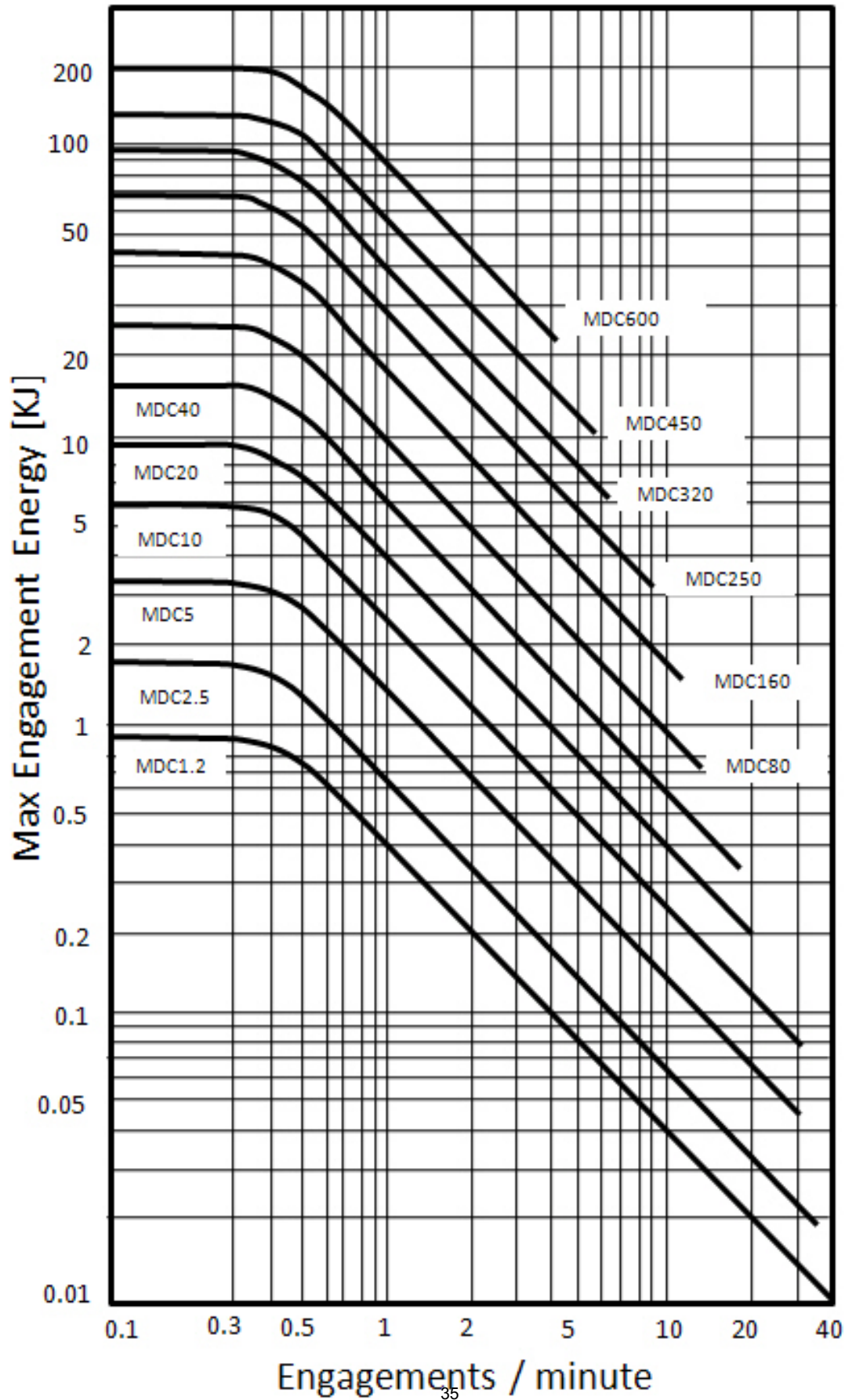

# UN

## Coupling for Multiple-Disk Clutch

Types: 1.2, 2.5, 5, 10, 20, 40, 80, 160, 250, 320, 450, 600

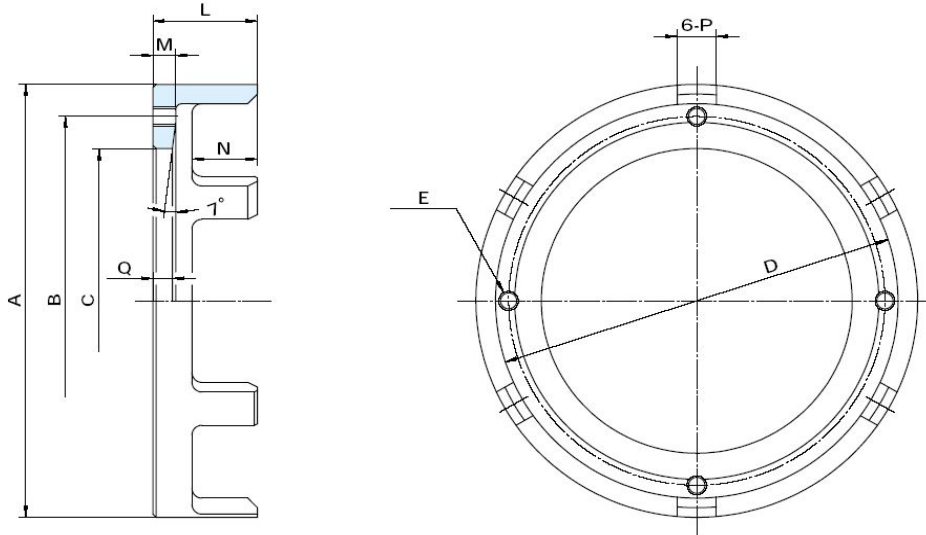

UN		1.2	2.5	5	10	20
Moment of Inertia (J) [kg-cm <sup>2</sup> ]		2.3	5	9.8	23.5	54
Dimensions [mm]	A	82	97	114	135	160
	B	68	80	95	115	135
	CH7	56	65	78	95	115
	D	74	88.5	104	123	146
	E	M5	M6	M6	M6	M8
	E (Qty)	4	4	4	6	6
	L	21.5	23	26	32	38
	M	5.5	6	6.5	7	10
	N	13	15	16	20	22
	Q	5	5	5.5	6	9
Weight [lbs / kg]		0.33 / 0.15	0.49 / 0.22	0.77 / 0.35	1.1 / 0.5	2.4 / 1.1

UN		40	80	160	250	320	450	600
Moment of Inertia (J) [kg-cm <sup>2</sup> ]		149	365	1080	2070	3280	8150	10800
Dimensions [mm]	A	198	238	294	330	355	404	444
	B	160	200	240	260	280	320	360
	CH7	135	170	200	220	240	280	310
	D	181.5	220	267.5	304	324	368	404
	E	M10	M12	M16	M16	M18	M20	M20
	E (Qty)	6	6	6	6	6	6	8
	L	48	60	75	82	97	105	122
	M	12	15	20	20	25	30	30
	N	26	34	38	44	52	53	72
	Q	10	13	17	17	22	27	27
Weight [lbs / kg]		4.6 / 2.1	6.6 / 3.0	16.0 / 7.3	21 / 9.5	30 / 14	44 / 20	55 / 25

[ 1 inch = 25.4 mm ]

# MW

S E R I E S

## WET-TYPE MULTIPLE-DISK ELECTROMAGNETIC CLUTCH & BRAKE

Torque Range: 18 ~ 8851 ft-lbs

Torque Range: 25 ~ 12000 N-m

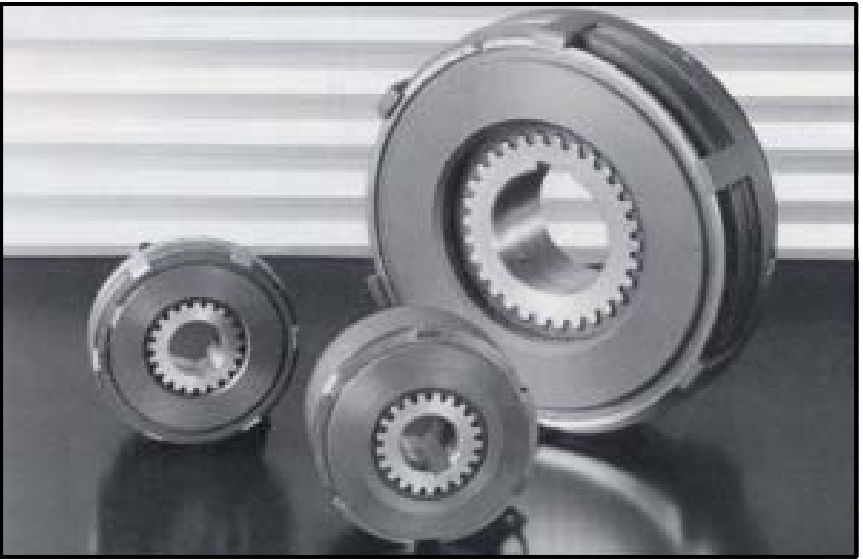

## FEATURES

### HIGH-TORQUE COMPACT DESIGN

The MW series are designed as extremely compact multiple disc units that deliver high torque rates.

### LONG LIFE AND LOW MAINTENANCE

The MW series stationary field design and oil lubrication system significantly reduce wear and maintenance while increasing operational life.

### QUICK RELEASE TIME

Separator springs between the friction plates allow for quick disconnect when the power is released. These springs also keep the disks from making contact with each other in the disengaged mode.

### FAST TORQUE BUILD-UP

An efficiently etched oil path on the friction disk, coupled with special treatment of the friction disks ensures fast response and release time.

### HIGH HEAT DISSIPATION

The oil lubrication system provides excellent heat dissipation making the MW series suitable for heavy duty operation.

### EASILY CONNECT TO YOUR GEAR, PULLEY OR COUPLING

The MD series is made to be used with the UN drive cup, the cup slides between the friction disk tangs and has a tapped bolt pattern so you can attach your bearing mounted gear pulley.



MWC



MWB



UN Drive Cup

# MWC

## Wet-Type Multiple-Disk EM Clutch

Types: 1.2, 2.5, 5, 10, 20

[ EM: Electromagnet ]

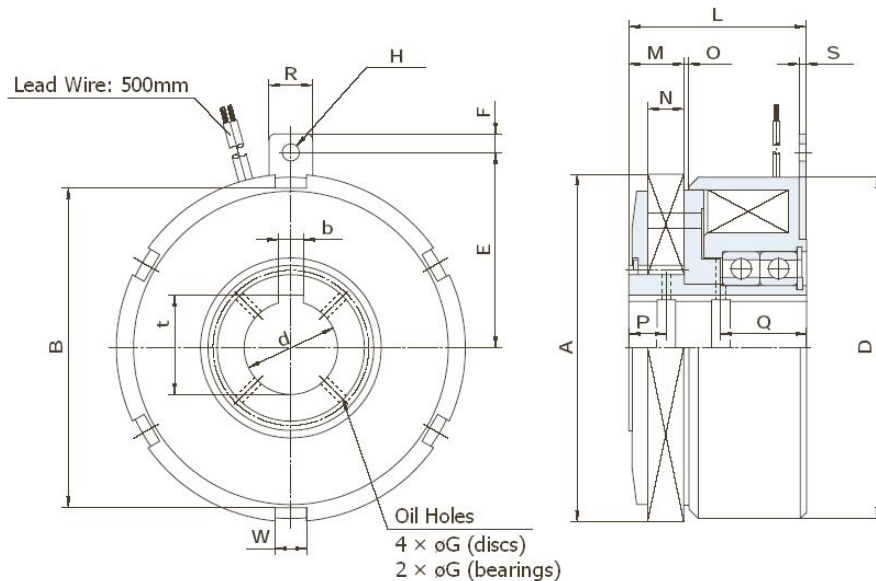

[ Special Order ]

MWC		1.2	2.5	5	10	20
Dynamic Torque [ft-lbs / N-m]		8.9 / 12	18 / 25	37 / 50	74 / 100	148 / 200
Static Torque [ft-lbs / N-m]		18 / 25	37 / 50	74 / 100	148 / 200	295 / 400
Coil (20°C)	Voltage [DC-V]	24				
	Current [A]	0.48	0.71	0.91	1.5	1.9
	Resistance [Ω]	49.5	34	26.4	16	12.8
	Wattage [W]	12	17	22	36	45
Armature Pull-In Time [ms]		50	60	70	80	100
Torque Build-Up Time [ms]		120	150	170	180	200
Torque Decay Time [ms]		40	50	60	70	100
Max Allowable Speed [rpm]		4000	3600	3200	3000	2800
Moment of Inertia (J) [kg-cm <sup>2</sup> ]	Hub	2.8	5.5	13.3	32	57
	Outer Disc	0.5	1.3	2.8	8.3	16.3
Bore [mm]	dH7	20	25	30	40	50
Key Way [mm]	bE9	6	8	8	12	14
	t+0.2/-0	21.7	26.7	32	42.5	52.5
Dimensions [mm]	A	80	95	112	132	157
	B	73	87.5	103	122	145
	D	78	93	110	130	155
	E	47	57	63	80	91
	F	6	6	6	8	8
	G	2	3	3	3	3
	H	5.5	5.5	5.5	6.5	6.5
	L	45	49	57	63	73
	M	13.5	14.8	17.7	22	24.5
	N	8.5	9.3	11.7	14	14
	O	2	2	1.5	2	2
	P	10	11	12	16	18
	Q	21.5	23.5	27.5	25	28.5
	R	12	14	14	16	16
	S	2	2.3	2.3	3	3
W	8	10	10	12	12	
W (Qty)	6	6	6	6	6	
Weight [lbs / kg]		3.1 / 1.4	4.4 / 2.0	6.6 / 3.0	11 / 5	17 / 8
Coupling		UN1.2	UN2.5	UN5	UN10	UN20



# MWC

## Wet-Type Multiple-Disk EM Clutch

Types: 40, 80, 160, 250, 320, 450, 600

[ EM: Electromagnet ]

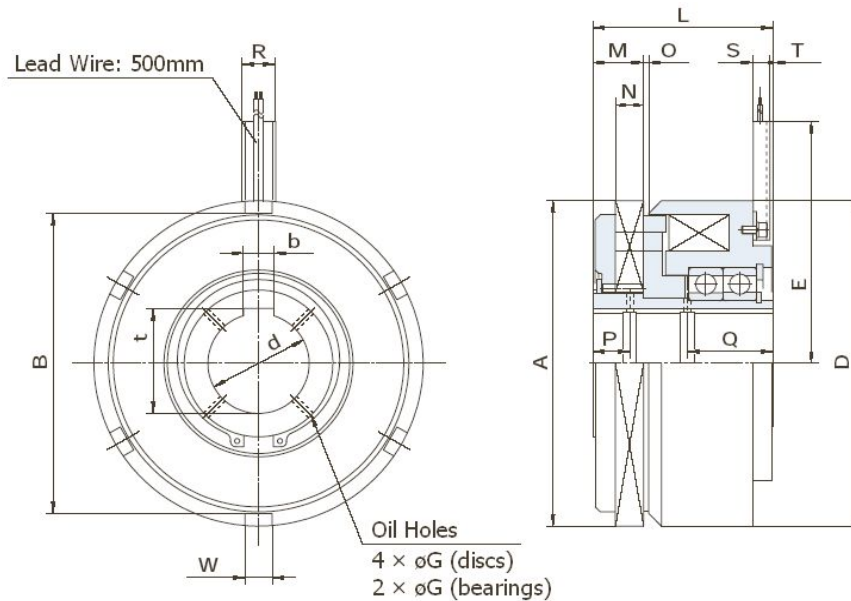

[ Special Order ]

MWC		40	80	160	250	320	450	600
Dynamic Torque [ft-lbs / N-m]		295 / 400	590 / 800	1180 / 1600	1844 / 2500	2360 / 3200	3319 / 4500	4425 / 6000
Static Torque [ft-lbs / N-m]		590 / 800	1180 / 1600	2360 / 3200	3688 / 5000	4720 / 6400	6638 / 9000	8851 / 12000
Coil (20°C)	Voltage [DC-V]	24						
	Current [A]	2	2.5	3.7	4.6	5.1	7.3	6.2
	Resistance [Ω]	12	9.6	6.5	5.2	4.7	3.3	3.9
	Wattage [W]	50	60	90	110	125	175	150
Armature Pull-In Time [ms]		150	250	380	550	700	1000	1500
Torque Build-Up Time [ms]		320	600	700	900	1200	1500	1800
Torque Decay Time [ms]		130	350	900	700	1000	1200	1500
Max Allowable Speed [rpm]		2400	2000	1600	1400	1200	1000	900
Moment of Inertia (J) [kg-cm <sup>2</sup> ]	Hub	258	713	1980	3450	5280	10300	15000
	Outer Disc	47	142	383	683	1060	2280	5300
Bore [mm]		dH7 60	70	90	100	110	120	140
Key Way [mm]	bE9	18	20	25	28	28	32	35
	t+0.2/-0	63	75	95	106.5	119	130	151
Dimensions [mm]	A	195	235	290	325	350	400	440
	B	180	218	265	300	320	363.5	400
	D	195	235	290	324	350	392	428
	E	145	160	200	220	230	250	270
	G	4	4	4	5	5	8	8
	L	107	135	170	185	210	220	255
	M	30.2	40	49	55	60.9	63	80
	N	16.7	23	28.4	32	36.1	34.2	53
	O	3	4	5	5	10.1	10	10
	P	22	30	35	39	43	45	54
	Q	51	61	75	84	97	101	123
	R	20	20	25	30	30	30	30
	S	10	10	18	15	15	15	15
	T	2	4	5	11	10	17	17
W	16	22	30	40	40	50	50	
W (Qty)	6	6	6	6	6	6	8	
Weight [lbs / kg]		37 / 17	71 / 32	123 / 56	174 / 79	229 / 104	309 / 140	423 / 192
Coupling		UN40	UN80	UN160	UN250	UN320	UN450	UN600

[ Included parts & accessories : surge protector ]

[ 1" = 25.4mm ]

# MWC: TYPICAL INSTALLATION

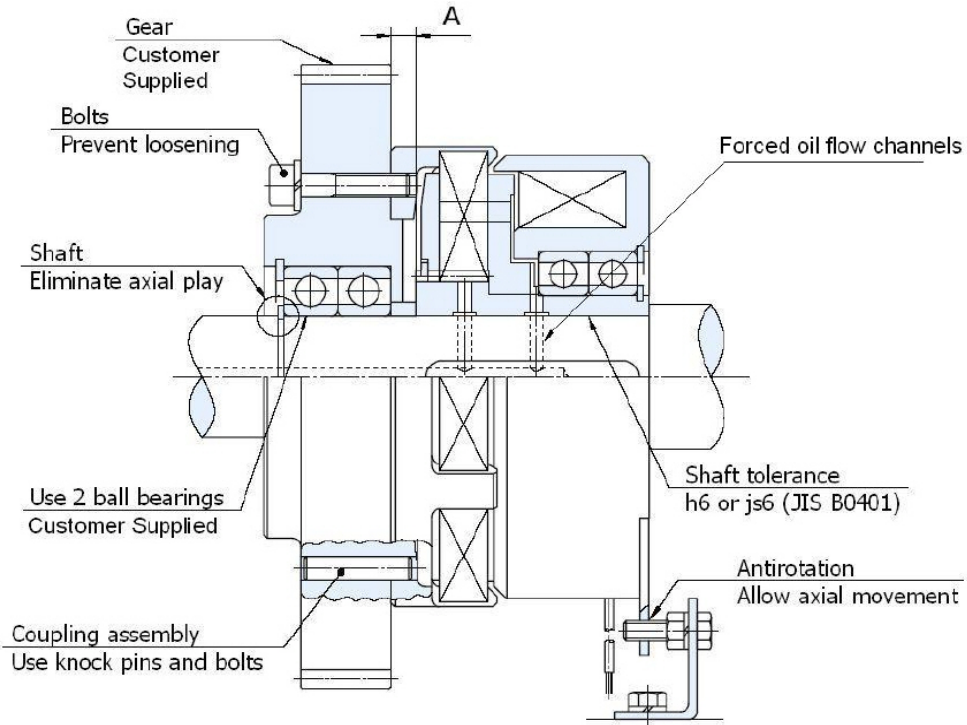

MWC as clutch coupling

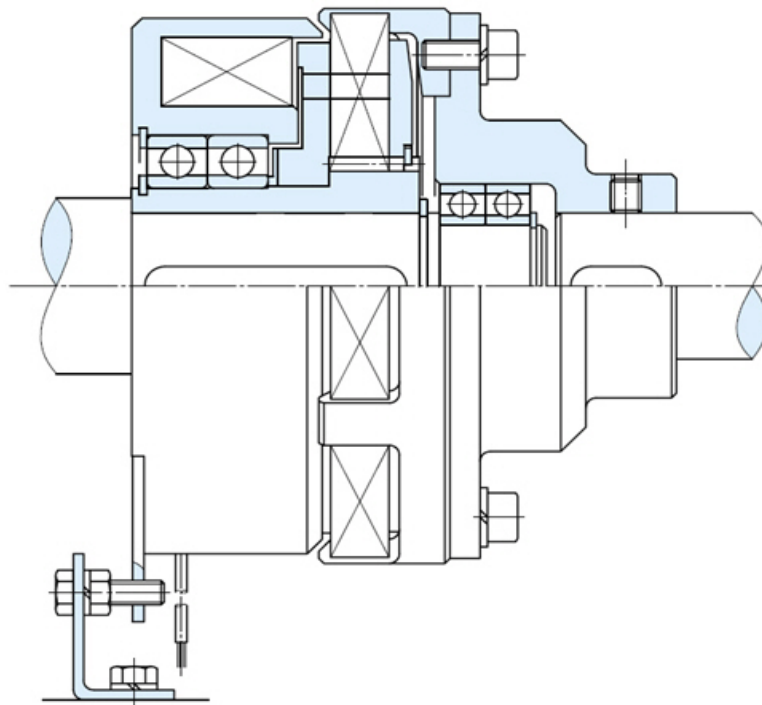

MWC	1.2	2.5	5	10	20	40
Dimension A [mm]	5.5	5.5	6	6.5	9.5	14
MWC	80	160	250	320	450	600
Dimension A [mm]	17	23	25	30	36	36

# MWC: MAX ENGAGEMENT ENERGY & DRAG TORQUE

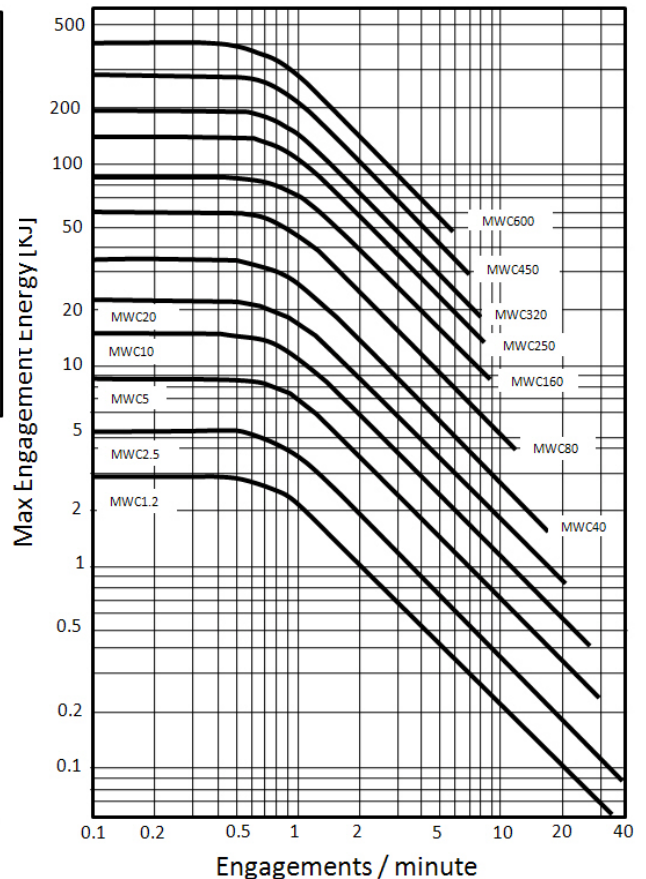
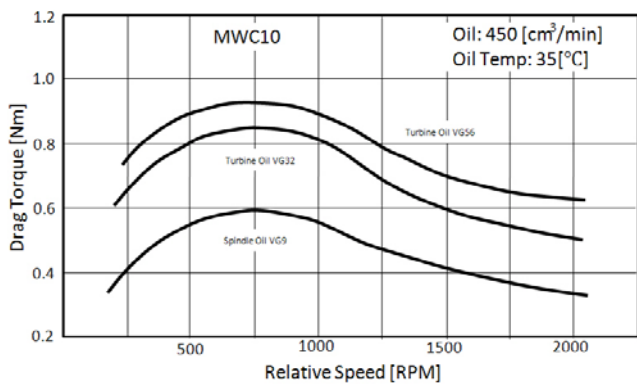
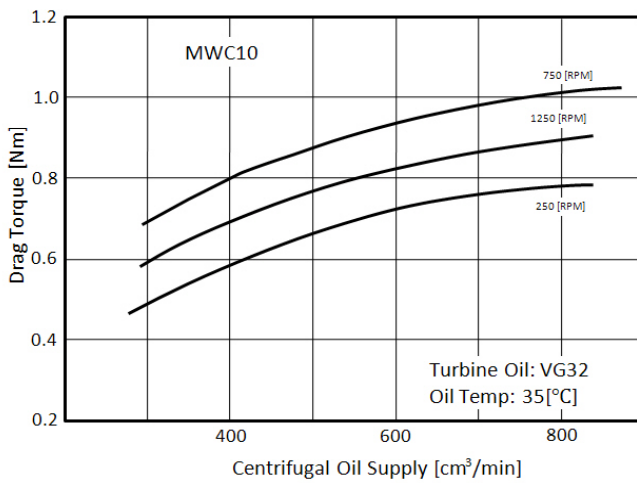
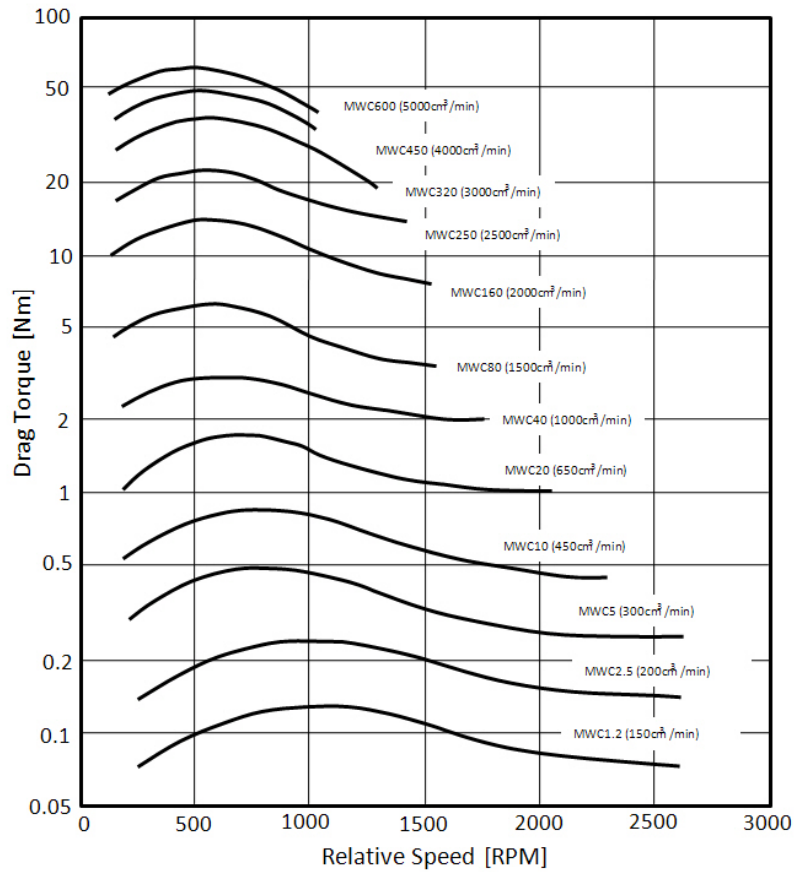

# MWC: DRAG TORQUE

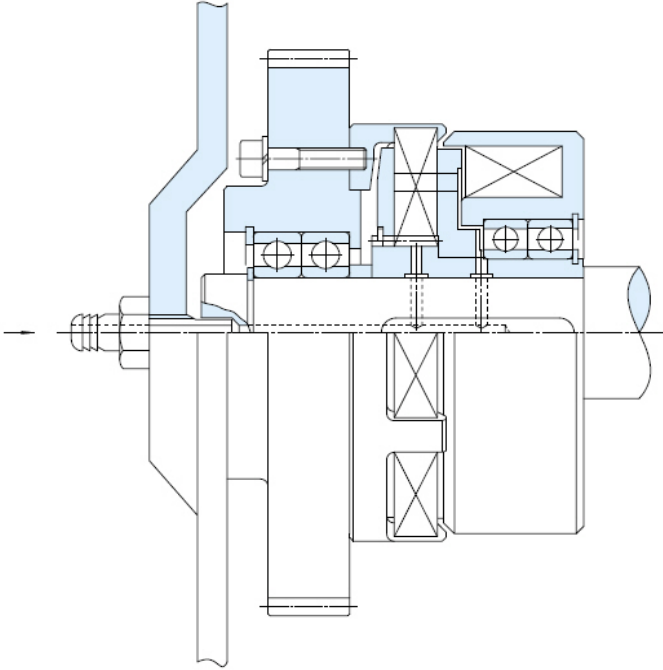

Shaft Lubrication System  
 Ideal when:  
 speed > 1000rpm  
 Shaft Orientation: Vertical  
 Load: High

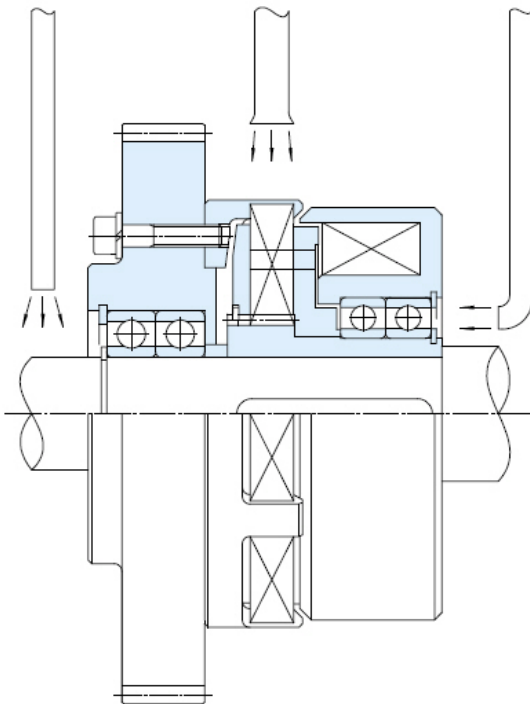

Spray System:  
 Can be used when:  
 Speed < 1000 rpm

Oil Bath System  
 Can be used when:  
 Speed < 1000 rpm  
 Or cycle: Low

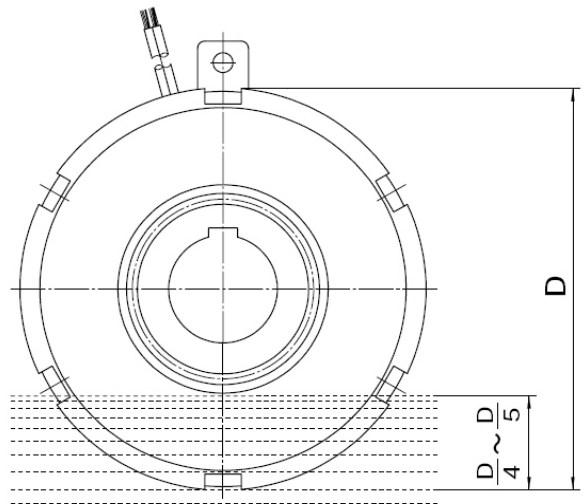

# UN

## Coupling for Multiple-Disk Clutch

Types: 1.2, 2.5, 5, 10, 20, 40, 80, 160, 250, 320, 450, 600

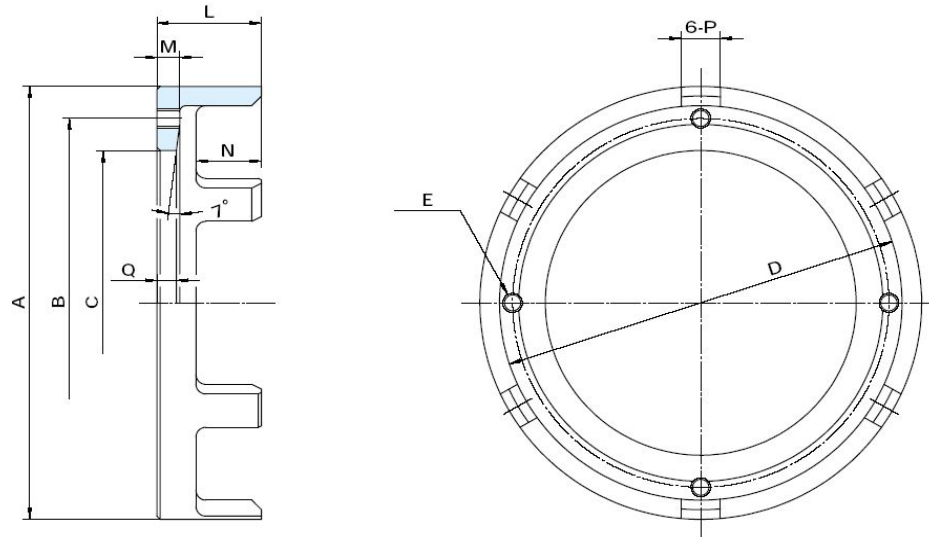

UN		1.2	2.5	5	10	20
Moment of Inertia (J) [kg-cm <sup>2</sup> ]		2.3	5	9.8	23.5	54
Dimensions [mm]	A	82	97	114	135	160
	B	68	80	95	115	135
	CH7	56	65	78	95	115
	D	74	88.5	104	123	146
	E	M5	M6	M6	M6	M8
	E (Qty)	4	4	4	6	6
	L	21.5	23	26	32	38
	M	5.5	6	6.5	7	10
	N	13	15	16	20	22
	P	8	10	10	12	12
Q	5	5	5.5	6	9	
Weight [lbs / kg]		0.33 / 0.15	0.49 / 0.22	0.77 / 0.35	1.1 / 0.5	2.4 / 1.1

UN		40	80	160	250	320	450	600
Moment of Inertia (J) [kg-cm <sup>2</sup> ]		149	365	1080	2070	3280	8150	10800
Dimensions [mm]	A	198	238	294	330	355	404	444
	B	160	200	240	260	280	320	360
	CH7	135	170	200	220	240	280	310
	D	181.5	220	267.5	304	324	368	404
	E	M10	M12	M16	M16	M18	M20	M20
	E (Qty)	6	6	6	6	6	6	8
	L	48	60	75	82	97	105	122
	M	12	15	20	20	25	30	30
	N	26	34	38	44	52	53	72
	P	16	22	30	40	40	50	50
Q	10	13	17	17	22	27	27	
Weight [lbs / kg]		4.6 / 2.1	6.6 / 3.0	16 / 7	21 / 10	30 / 14	44 / 20	55 / 25

[ 1 inch = 25.4 mm ]

# MZ

S E R I E S

## ELECTROMAGNETIC TOOTH CLUTCH

Torque Range: 18 ~ 2950 ft-lbs.

Torque Range: 25 ~ 4000 N-m



## FEATURES

### ZERO BACKLASH

The MZ series provides minimal backlash. Backlash can be totally eliminated as an option.

### ZERO DRAG TORQUE

There is no drag torque in the disengaged mode because both faces separate completely.

### NO SLIP

Driving torque is via teeth, therefore slippage is non-existent when the clutch is engaged.

### WET / DRY APPLICATIONS

The MZ series clutches can be used in either wet or dry applications.

### HIGH-TORQUE COMPACT DESIGN

The MZ Series tooth engagement clutches provide the highest torque per size of any electromagnetic clutch style.

### FLEXIBLE MOUNTING

Clutches are supplied with armature assembly only which should be bolted into customer's gear, pulley or coupling.

### LONG LIFE

Since tooth wear is minimal, the MZ series has an extremely long operational life.



MZ 2.5 ~ 50



MZ 100 ~ 400



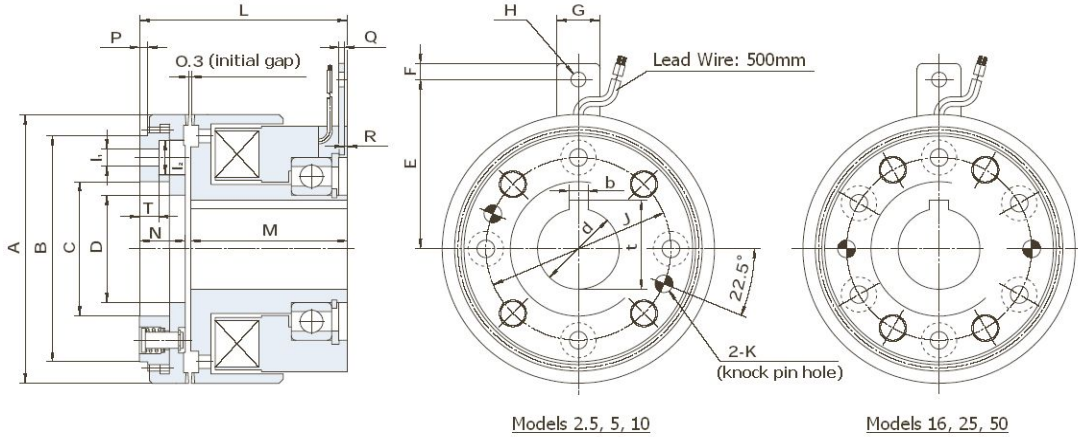

MZ	Dry Type	2.5D	5D	10D	16D	25D	50D
	Wet Type	2.5W	5W	10W	16W	25W	50W
Static Torque [ft-lbs / N-m]		18 / 25	37 / 50	74 / 100	118 / 160	184 / 250	369 / 500
Coil (20°C)	Voltage [DC-V]	24					
	Current [A]	0.63	0.96	1.25	1.46	1.67	2.08
	Resistance [Ω]	38.4	25	19.2	16.5	14.4	11.5
	Wattage [W]	15	23	30	35	40	50
Armature	Pull-In Time [ms]	60	70	90	100	140	170
	Release Time [ms]	60	70	90	100	140	170
Max Allowable Speed [rpm]		5000	4500	3800	3500	3200	2700
Max Engagement Speed [rpm]		38	34	28	26	24	20
Moment of Inertia (J) [kg-cm <sup>2</sup> ]	Rotor	2.5	5	11	21.3	35	94.5
	Armature	2.5	4.5	8.3	15.3	29	60
Bore [mm]		dH7	20	25	30	35	40
Key Way [mm]	bE9	5	7	7	10	10	12
	t+0.15/-0	22	28	33	38.5	43.5	53.5
Dimensions [mm]	A	75	85	100	110	120	140
	Bh7	62	70	84	90	98	112
	CH7	38	45	50	65	65	70
	D	29	34	40	46	51	62
	E	54	58	63	68	73	88
	F	6	6	6	6	6	10
	G	16	16	16	16	16	24
	H	5.5	5.5	5.5	5.5	5.5	8.5
	I1	4x4.5	4x5.5	4x6.5	6x5.5	6x6.5	6x8.5
	I2	8	10	13	10	13	16
	J	50	58	68	78	82	92
	K	4.8	5.8	5.8	7.8	7.8	9.8
	L	67	72	75	82	92	112
	M	52	55	57	62	70	85
	N	13.7	15.5	16.5	18.5	20.5	25.5
	P	3	3	3	3	3	3
Q	2	2	2	2	2	2.9	
R	-	-	0.5	0.5	1	-	
T	5	6	7	7	8	10	
Weight [lbs / kg]		3.3 / 1.5	4.4 / 2.0	6.6 / 3.0	8.8 / 4.0	11 / 5	19 / 9

[ Included parts & accessories : surge protector ]

[ 1" = 25.4mm ]

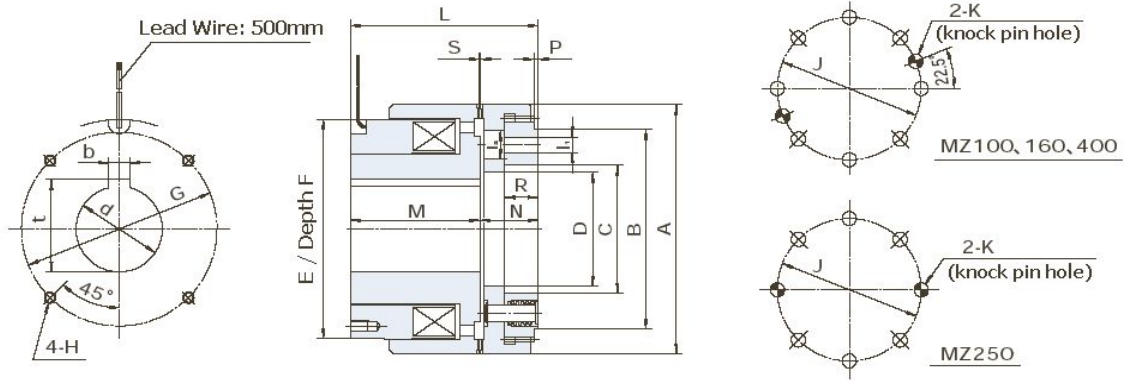

MZ		100	160	250	400
Static Torque [ft-lbs / N-m]		738 / 1000	1180 / 1600	1844 / 2500	2950 / 4000
Coil (20°C)	Voltage [DC-V]	24			
	Current [A]	2.67	3.33	3.75	4.13
	Resistance [Ω]	9	7.2	6.4	5.8
	Wattage [W]	65	80	90	100
Armature	Pull-In Time [ms]	250	300	380	450
	Release Time [ms]	250	300	350	400
Max Allowable Speed [rpm]		2200	2000	1600	1400
Max Engagement Speed [rpm]		0	0	0	0
Moment of Inertia (J) [kg-cm <sup>2</sup> ]	Rotor	275	480	1210	1670
	Armature	220	490	920	1440
Bore [mm]	dH7	60	70	90	100
Key Way [mm]	bE9	15	18	24	28
	t+0.15/-0	65	76	98	109
Dimensions [mm]	A	175	196	237	258
	Bh7	140	160	185	208
	Ch7	90	100	130	140
	D	80	92	120	126
	Eh8	154	176	209	229
	F	5	5	5	5
	G	136	156	190	210
	H	M8-12	M8-12	M10-20	M10-20
	I1	8-11	8-13	6-18	8-18
	I2	20	24	30	30
	J	118	136	155	175
	K	11.7	15.5	15.5	15.5
	L	130	134	150	160
	M	90	90	100	105
	N	40	44	50	55
P	3	4	4	4	
R	23.5	25	27	30	
S	0.3~0.5	0.4~0.6	0.6~0.8	0.6~0.8	
Weight [lbs / kg]		37 / 17	55 / 25	77 / 35	97 / 44

# MZ: TYPICAL INSTALLATION

## Models 2.5~50

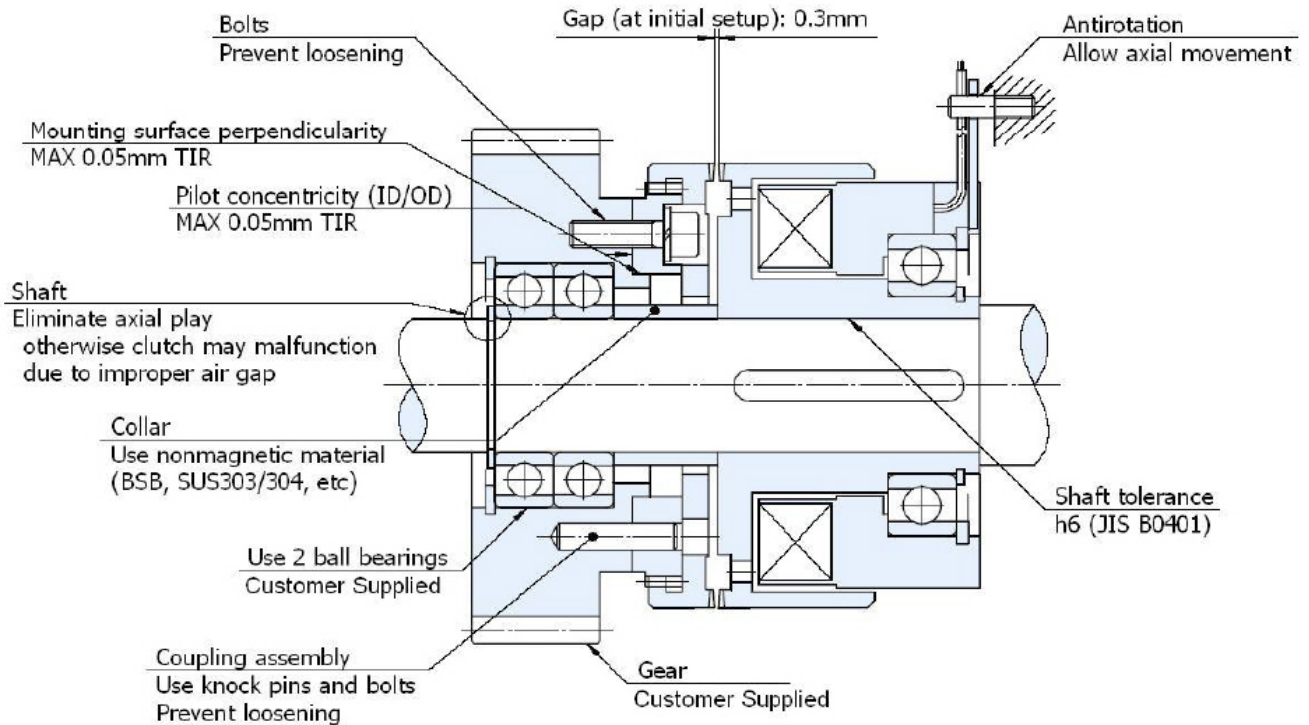

## Models 100~400

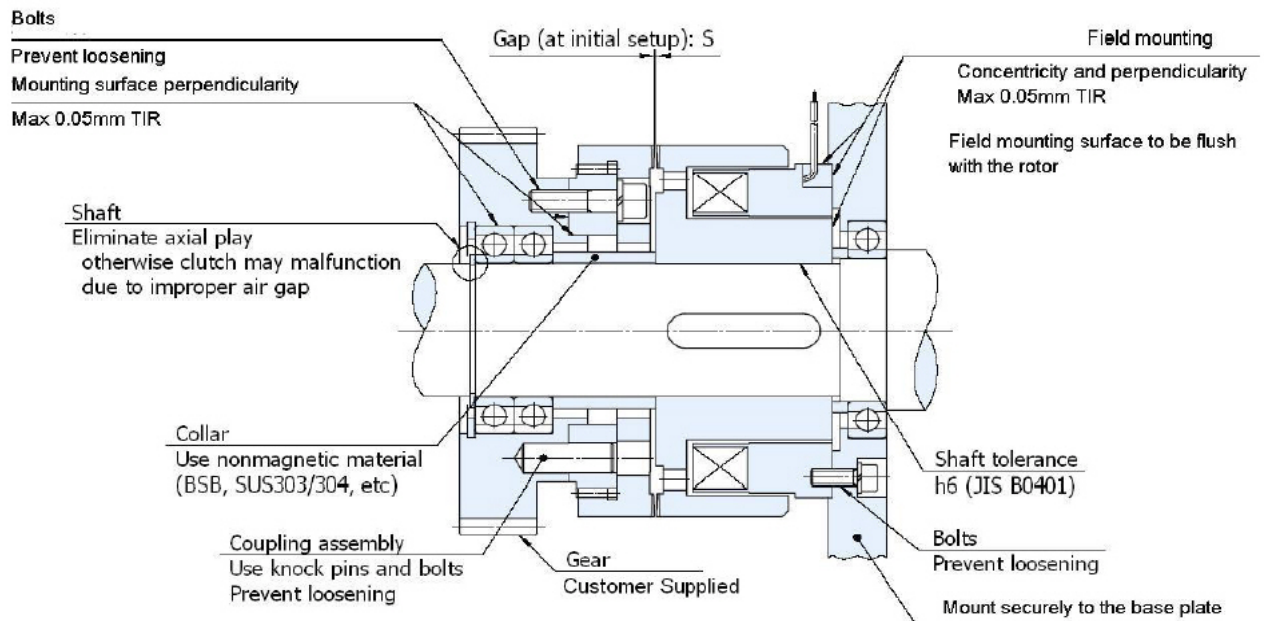

## MZ: TORQUE CHARACTERISTIC

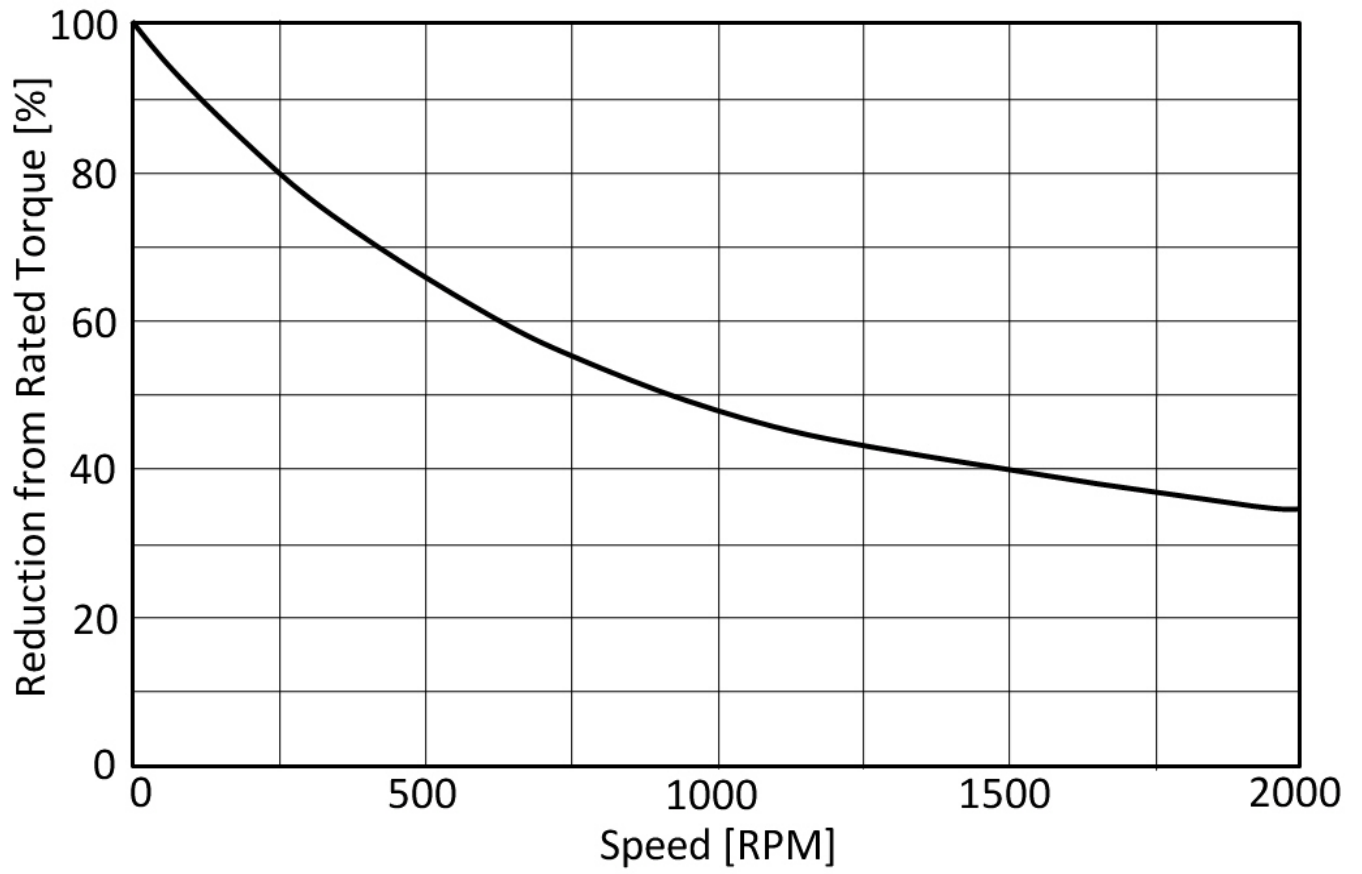

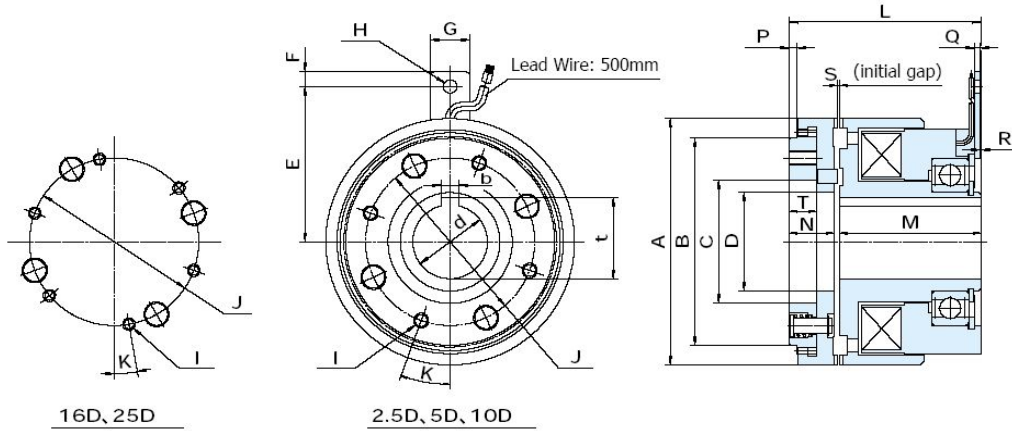

16D, 25D

2.5D, 5D, 10D

MZS		2.5D	5D	10D	16D	25D
Static Torque [ft-lbs / N-m]		18 / 25	37 / 50	74 / 100	118 / 160	184 / 250
Coil (20°C)	Voltage [DC-V]	24				
	Current [A]	0.63	0.96	1.25	1.46	1.67
	Resistance [Ω]	38.4	25	19.2	16.5	14.4
	Wattage [W]	15	23	30	35	40
Armature	Pull-In Time [ms]	90	90	90	100	140
	Release Time [ms]	60	70	100	110	140
Max Allowable Speed [rpm]		5000	4500	3800	3500	3200
Moment of Inertia (J) [kg-cm <sup>2</sup> ]	Rotor	2.5	5	11	21.3	35
	Armature	3.5	6	10.5	18.7	29
Bore [mm]	dH7	20	25	30	35	40
Key Way [mm]	bE9	5	7	7	10	10
	t+0.15/-0	22	28	33	38.5	43.5
Dimensions [mm]	A	75	85	100	110	120
	Bh7	62	70	84	90	98
	Ch7	38	45	50	65	65
	D	29	34	40	46	51
	E	54	58	63	68	73
	F	6	6	6	6	6
	G	16	16	16	16	16
	H	5.5	5.5	5.5	5.5	5.5
	I	4xM4	4xM5	4xM6	6xM5	6xM6
	J	50	58	68	78	82
	K	10°	15°	20°	10°	10°
	L	68.5	73.5	76.5	83.5	92
	M	52	55	57	62	70
	N	15.2	17	17.8	19.7	20.2
	P	3	3	3	3	3
	Q	2	2	2	2	2
R	-	-	0.5	0.5	1	
S	0.4~0.5	0.4~0.5	0.5~0.6	0.6~0.7	0.6~0.7	
T	10	10.8	10.8	11.7	12.4	
Weight [lbs / kg]		3.3 / 1.5	4.4 / 2.0	6.6 / 3.0	8.8 / 4.0	11.0 / 5.0

[ Included parts & accessories : surge protector ]

[ 1" = 25.4mm ]

# AMB

S E R I E S

## ELECTROMAGNETIC BRAKE

Torque Range: 2.2 ~ 71 in-lbs

Torque Range: 0.25 ~ 8 N-m



## FEATURES

### EASY MOUNTING AND MAINTENANCE

The brake flange mounts to the customer's machine via the four mounting holes. The bore of the brake can also be used to house a bearing which can reduce the overall length of the machine and cost because the brake body acts as a bearing housing.

### ZERO BACKLASH

By mounting the armature to the hub via leaf springs, backlash is minimized and armature rattle is eliminated.

### CONTROLLABLE RESPONSE TIME

Variations in acceleration or deceleration times and slip torque can be achieved by controlling the applied current.

### FAST RESPONSE

Elimination of splines provides faster response and high performance by overcoming friction in the armature and hub.

### HIGH HEAT DISSIPATION

The AM series units perform relentlessly year after year, even in heavy duty applications, due to their excellent heat dissipation.



AMB



# AMB

## Micro EM Brake

Types: 2.5, 5, 10, 20, 40, 80

[ EM: Electromagnet ]

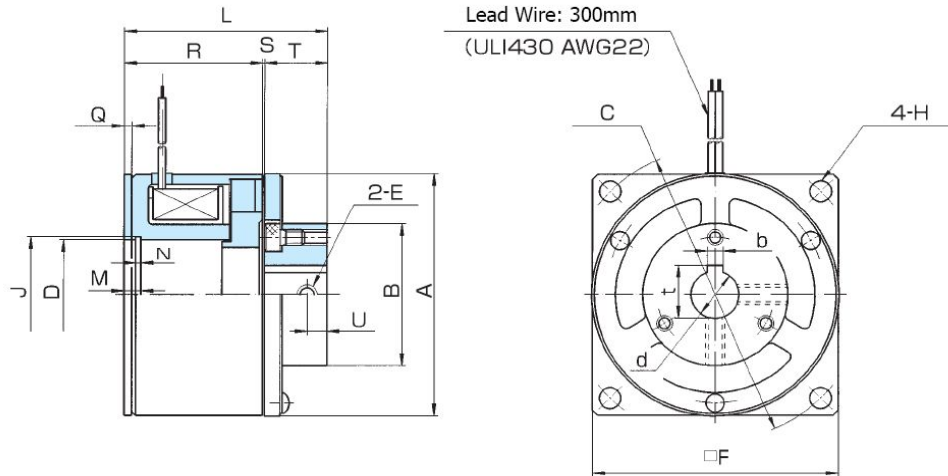

AMB		2.5	5	10	20	40	80
Static Torque [in-lbs / N-m]		2.2 / 0.25	4.4 / 0.5	8.9 / 1	18 / 2	35 / 4	71 / 8
Coil (20°C)	Voltage [DC-V]	24					
	Current [A]	0.13	0.17	0.25	0.26	0.38	0.48
	Resistance [Ω]	192	144	96	94	64	50
	Wattage [W]	3	4	6	6.1	9	11.5
	Time Constant [ms]	4	7	10	11	19	24
Armature	Pull-In Time [ms]	10	13	17	21	32	37
	Release Time [ms]	15	20	25	26	40	45
Torque Build-Up Time [ms]		15	17	27	35	55	60
Max Allowable Speed [rpm]		3600	3600	3600	3600	3600	3600
Moment of Inertia (J) [kg-cm <sup>2</sup> ]		0.035	0.055	0.103	0.193	0.495	1.05
MaxAir Gap Until Adjustment [mm]		0.4	0.45	0.55	0.6	0.7	0.7
Total Energy Until Adjustment [J]		2.8 x 10 <sup>6</sup>	4.5 x 10 <sup>6</sup>	7.5 x 10 <sup>6</sup>	1.2 x 10 <sup>7</sup>	1.8 x 10 <sup>7</sup>	2.7 x 10 <sup>7</sup>
Total Energy Until Life [J]		8.7 x 10 <sup>6</sup>	1.4 x 10 <sup>7</sup>	2.3 x 10 <sup>7</sup>	3.8 x 10 <sup>7</sup>	5.8 x 10 <sup>7</sup>	8.5 x 10 <sup>7</sup>
Max Work Rate [W]		18	20	26	30	40	55
Bore [mm]	dH8	6	6	8	10	12	15
Key Way [mm]	bE9	2	2	2.5	4	4	5
	t+0.1/-0	6.9	6.9	8.9	11.5	13.5	17
Dimensions [mm]	A	35	40	46	51	61	70
	B	22	22	26	31	36	40
	C	42	48	56	63	74	84
	DH7	15	15	22	26	28	32
	E	M3	M3	M4	M4	M5	M5
	F	35	40.2	46.2	53	61	70.2
	H	3.3	3.3	4.5	4.5	5.3	5.3
	J	15.7	15.7	23	27.2	29.4	33.7
	L	31	31	39.8	44.3	50.5	53.5
	M	3.5	3.5	3.5	4.2	4.2	4.2
	N	1.15	1.15	1.15	1.35	1.35	1.35
	Q	1.4	1.4	1.4	1.4	1.9	1.9
	R	21.8	21.8	27.55	30.05	34.5	35.5
S	0.15~0.25	0.15~0.25	0.2~0.3	0.2~0.3	0.25~0.35	0.25~0.35	
T	9	9	12	14	15.7	17.7	
U	3	3	4	5	5	5	
Weight [lbs / kg]		0.28 / 0.13	0.37 / 0.17	0.56 / 0.25	0.82 / 0.37	1.3 / 0.6	1.9 / 0.9

# AMB: TYPICAL INSTALLATION

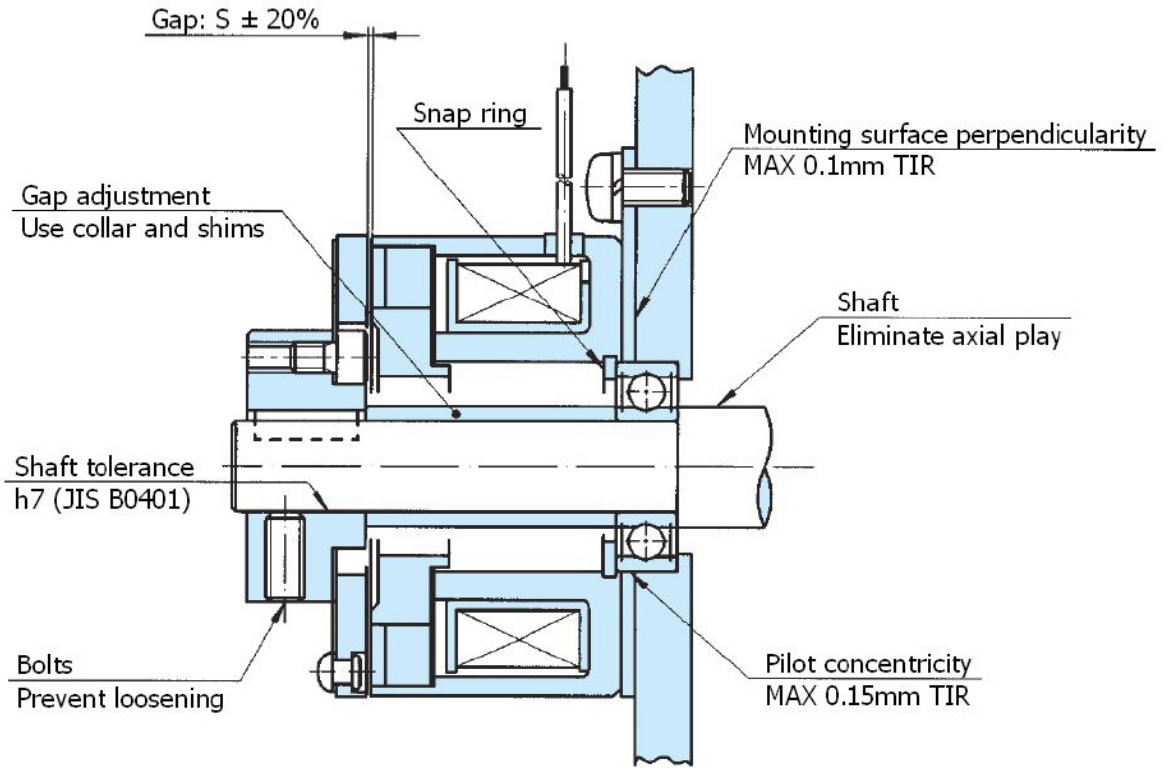

# AMB: TORQUE CHARACTERISTIC & MAX WORK RATE

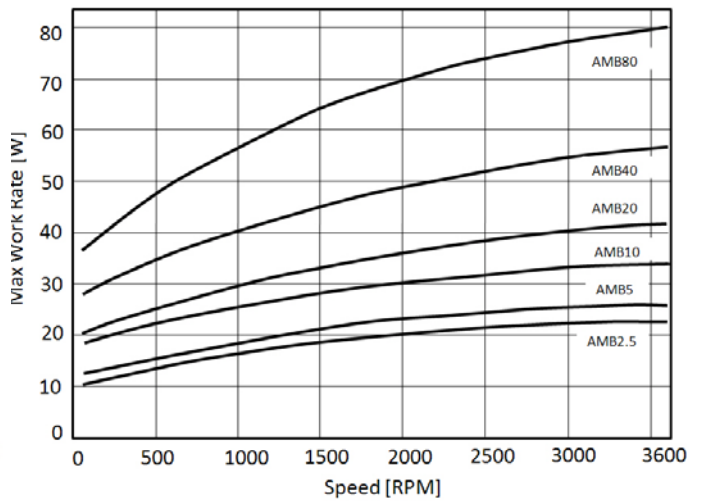
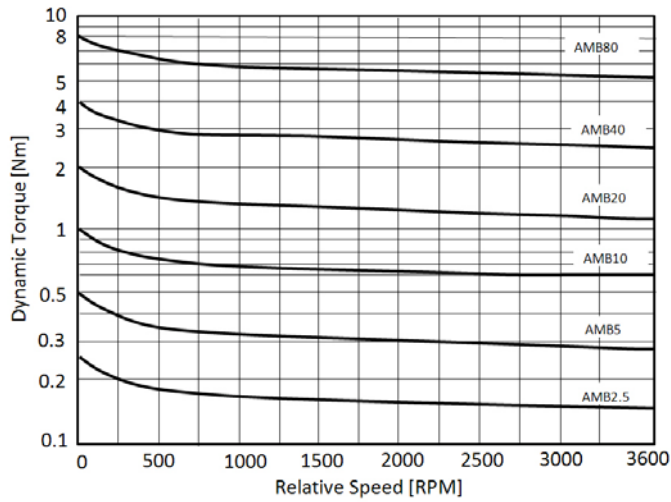

# VB

## S E R I E S

### ELECTROMAGNETIC BRAKE

Torque Range: 4.4 ~ 44 ft-lbs

Torque Range: 6 ~ 60 N-m



## FEATURES

### FAST RESPONSE

The V series brakes are dry type single disc units. This ensures fast response in high speed, high cycle applications.

### ZERO BACKLASH

The armature is mounted to the hub by special leaf springs to provide minimal backlash and no armature rattle.

### HIGH TORQUE VERSIONS AVAILABLE (H series)

Both standard units and high torque (H) versions are shown in the following data sheets. The high torque versions have identical diameters to the standard versions, however they are slightly longer to allow for a higher power coil.

### AUTOMATIC GAP ADJUSTMENT (OPTIONAL)

The air gap is automatically adjusted as the friction surfaces wear during the entire life of the unit, increasing longevity by 50%.

### QUIET ARMATURE (OPTION S)

To help dampen the noise that sometimes occurs during engagement, Ogura has developed a quiet armature option that is available on all V series models.

### ONE-PIECE DESIGN (OPTION P)

One-piece design simplifies mounting.

### COMPACT DESIGN

The compact design of the V-series reduces mounting requirements during installation.



VBE/VBEH



VBE-P/VBEH-P



VBEHA



VSAU



VBS/VBSH



VBS-P/VBSH-P



VBSHA

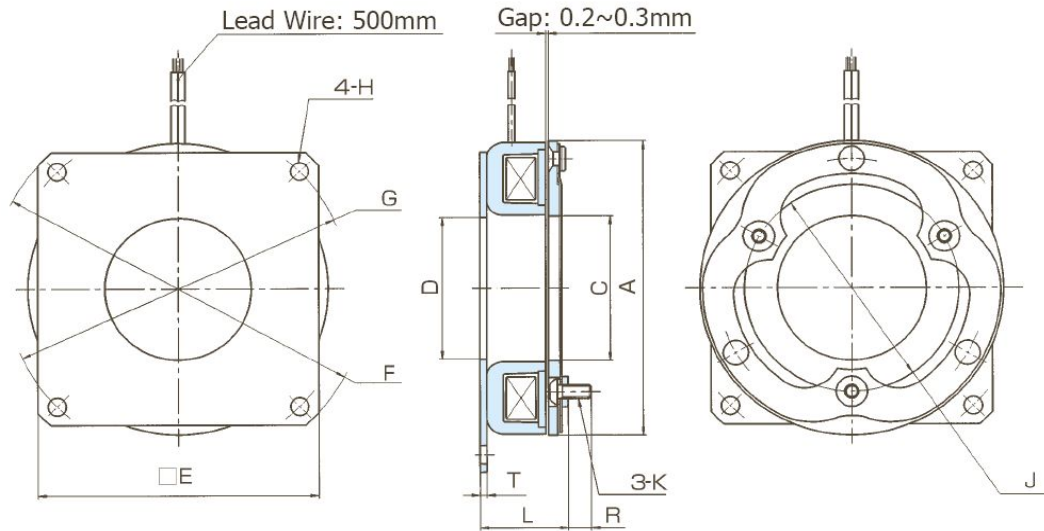

VBE / VBS Type		[ Special ] 0.6		[ Special ] 1.2		[ Special ] 2.5		[ Special ] 5		[ Special ] 10		[ Special ] 20	
		VBE	VBS <sup>1</sup>	VBE	VBS <sup>1</sup>	VBE	VBS <sup>1</sup>	VBE	VBS <sup>1</sup>	VBE	VBS <sup>1</sup>	VBE	VBS <sup>1</sup>
Static Torque [ft-lbs / N-m]		4.4 / 6		8.9 / 12		18 / 25		37 / 50		74 / 100		148 / 200	
Coil (20°C)	Voltage [DC-V]	24											
	Current [A]	0.5		0.62		0.92		1.41		1.6		2.2	
	Resistance [Ω]	48		39		26		17		15		11	
	Wattage [W]	12		15		22		33		38		53	
Armature	Pull-In Time [ms]	10		15		20		25		40		55	
	Release Time [ms]	20		30		50		70		35		62	
Torque Build-Up Time [ms]		40		45		60		65		78		95	
Max Allowable Speed [rpm]		7000		6000		5500		4500		3600		3000	
Moment of Inertia (J) [kg-cm <sup>2</sup> ]		0.5	0.5	1.5	1.6	4.8	5.1	14.3	15.1	45	45	136	136
Max Air Gap Until Adjustment [mm]		0.5		0.6		0.7		0.8		1.2		1.5	
Total Energy Until Adjustment [J]		2.9 x 10 <sup>7</sup>		6.6 x 10 <sup>7</sup>		13 x 10 <sup>7</sup>		26 x 10 <sup>7</sup>		62 x 10 <sup>7</sup>		120 x 10 <sup>7</sup>	
Total Energy Until Life [J]		13 x 10 <sup>7</sup>		25 x 10 <sup>7</sup>		49 x 10 <sup>7</sup>		88 x 10 <sup>7</sup>		170 x 10 <sup>7</sup>		320 x 10 <sup>7</sup>	
Dimensions [mm]	A	67		86		108		136		170		215	
	C	35		45		53		66		83		107	
	D+0.2/-0	35		45		52		65		80		107	
	E	62		82		100		125		156		200	
	F+0/-0.2	85		110		135		165		210		265	
	G	75		98		122		150		190		240	
	H	4.5		5.5		6.5		6.5		8.5		11	
	J	46		60		76		95		120		158	
	K	M3		M4		M5		M6		M8		M10	
	L	24.5	25	27.5	28	31.5	32.4	35	36	40	40	47.5	47.5
	R	5.8	5.4	7	6.6	8.2	7.6	10.4	9.6	14	14	17.5	17.5
	T	1.8		2.1		2.4		2.4		2.7		3	
Weight [lbs / kg]		0.71 / 0.32		1.3 / 0.6		2.4 / 1.1		4.4 / 2.0		8.2 / 3.7		15.4 / 7.0	

[ Included parts & accessories : bolts, washers, spacers, surge protector ]

[ 1 inch = 25.4 mm ]

[ Note 1 : Silent type ]

# VBEH / VBSH

# EM Brake (high torque design)

Types: 0.6, 1.2, 2.5, 5

[ EM: Electromagnet ]

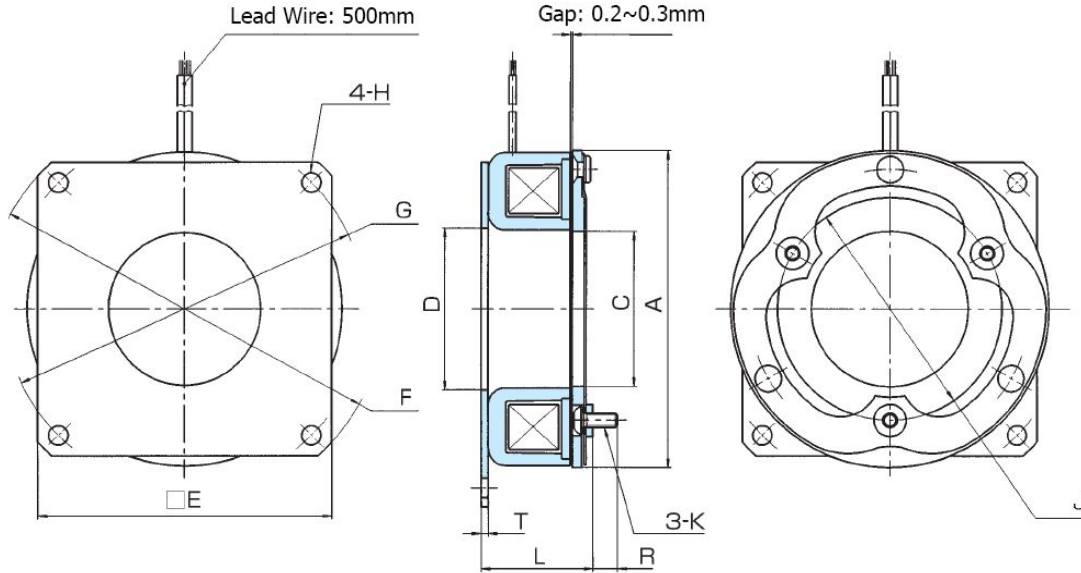

[ Special Order ]

VBEH / VBSH		0.6		1.2		2.5		5	
Type		VBEH	VBSH <sup>1</sup>	VBEH	VBSH <sup>1</sup>	VBEH	VBSH <sup>1</sup>	VBEH	VBSH <sup>1</sup>
Static Torque [ft-lbs / N-m]		5.2 / 7		11 / 15		22 / 30		44 / 60	
Coil (20°C)	Voltage [DC-V]	24							
	Current [A]	0.5		0.75		0.92		1.41	
	Resistance [Ω]	48		32		26		17	
	Wattage [W]	12		18		22		33	
Armature	Pull-In Time [ms]	10		10		15		20	
	Release Time [ms]	25		35		55		75	
Torque Build-Up Time [ms]		40		40		55		60	
Max Allowable Speed [rpm]		7000		6000		5500		4500	
Moment of Inertia (J) [kg-cm <sup>2</sup> ]		0.5	0.5	1.5	1.6	4.8	5.1	14.3	15.1
Total Energy Until Life [J]		13 x 10 <sup>7</sup>		25 x 10 <sup>7</sup>		49 x 10 <sup>7</sup>		88 x 10 <sup>7</sup>	
Dimensions [mm]	A	67		86		108		136	
	C	35		45		53		66	
	D+0.2/-0	35		45		52		65	
	E	62		82		100		125	
	F+0/-0.2	85		110		135		165	
	G	75		98		122		150	
	H	4.5		5.5		6.5		6.5	
	J	46		60		76		95	
	K	M3		M4		M5		M6	
	L	30	30.5	33.6	34.1	38	38.9	41.5	42.5
R	5.8	5.4	7	6.6	8.2	7.6	10.4	9.6	
T	1.8		2.1		2.4		2.4		
Weight [lbs / kg]		0.82 / 0.37		1.4 / 0.6		2.6 / 1.2		4.9 / 2.2	

[ Included parts & accessories : bolts, washers, spacers, surge protector ]

[ 1 inch = 25.4 mm ]

[ Note 1 : Silent type ]

# VBE-P / VBS-P

# EM Brake (one piece design)

Types: 1.2, 2.5, 5

[ EM: Electromagnet ]

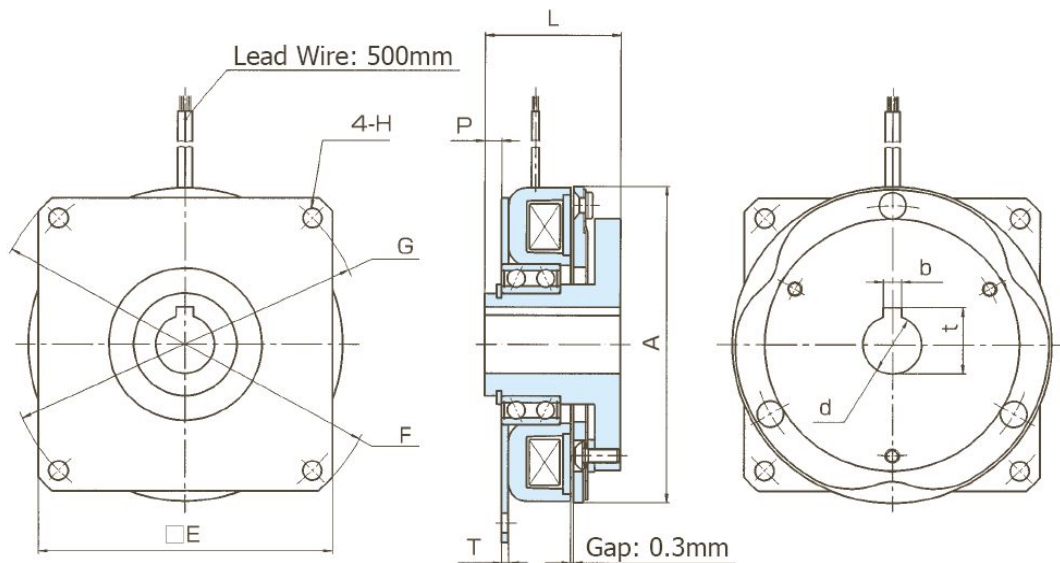

[ Special Order ]

VBE / VBS		1.2P		2.5P		5P	
Type		VBE	VBS <sup>1</sup>	VBE	VBS <sup>1</sup>	VBE	VBS <sup>1</sup>
Static Torque [ft-lbs / N-m]		8.9 / 12		18 / 25		37 / 50	
Coil (20°C)	Voltage [DC-V]	24					
	Current [A]	0.62		0.92		1.41	
	Resistance [Ω]	39		26		17	
	Wattage [W]	15		22		33	
Armature	Pull-In Time [ms]	15		20		25	
	Release Time [ms]	30		50		70	
Torque Build-Up Time [ms]		45		60		65	
Max Allowable Speed [rpm]		6000		5500		4500	
Moment of Inertia (J) [kg-cm <sup>2</sup> ]		3.3	3.3	9.6	9.9	26.8	27.5
Total Energy Until Life [J]		13 x 10 <sup>7</sup>		25 x 10 <sup>7</sup>		49 x 10 <sup>7</sup>	
Bore [mm]	dH7	15		20		25	
Key Way [mm]	bJs9	5		6		8	
	t	17.3+0.15/-0		22.8+0.15/-0		28.3+0.2/-0	
Dimensions [mm]	A	86		108		136	
	E	82		100		125	
	F	110		135		165	
	G	98		122		150	
	H	5.5		6.5		6.5	
	L	40		46		49	
	P	4.5	4	5.5	4.6	3	2
T	2.1		2.4		2.4		
Weight [lbs / kg]		2.4 / 1.1		4.4 / 2.0		7.7 / 3.5	

[ Included parts & accessories : surge protector ]

[ 1 inch = 25.4 mm ]

[ Note 1 : Silent type ]



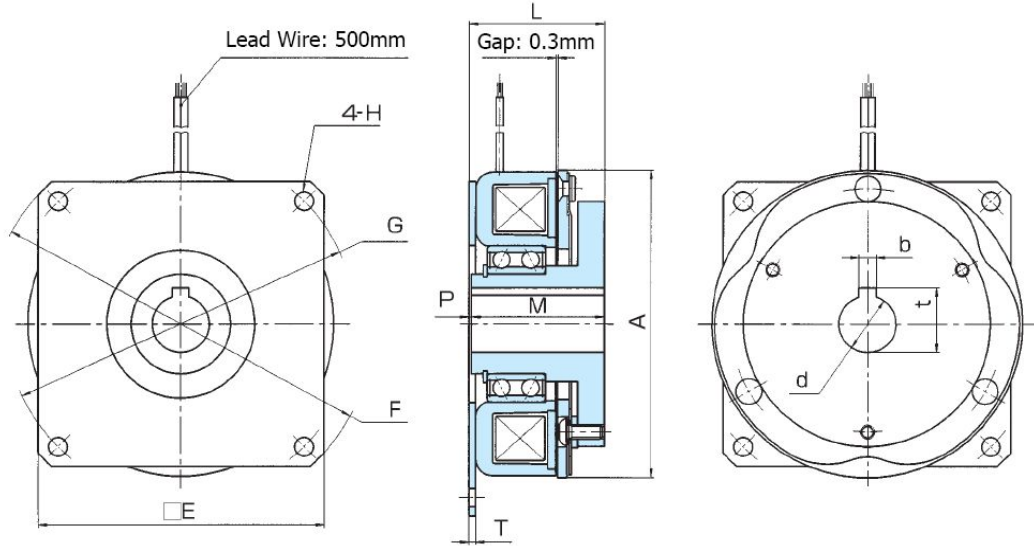

[ Special Order ]

VBEH / VBSH		1.2P		2.5P		5P	
Type		VBEH	VBSH <sup>1</sup>	VBEH	VBSH <sup>1</sup>	VBEH	VBSH <sup>1</sup>
Static Torque [ft-lbs / N-m]		11 / 15		22 / 30		44 / 60	
Coil (20°C)	Voltage [DC-V]	24					
	Current [A]	0.75		0.92		1.41	
	Resistance [Ω]	32		26		17	
	Wattage [W]	18		22		33	
Armature	Pull-In Time [ms]	10		15		20	
	Release Time [ms]	35		55		75	
Torque Build-Up Time [ms]		40		55		60	
Max Allowable Speed [rpm]		6000		5500		4500	
Moment of Inertia (J) [kg-cm <sup>2</sup> ]		3.3	3.3	9.6	9.9	26.8	27.5
Total Energy Until Life [J]		13 x 10 <sup>7</sup>		25 x 10 <sup>7</sup>		49 x 10 <sup>7</sup>	
Bore [mm]	dH7	15		20		25	
Key Way [mm]	bJs9	5		6		8	
	t	17.3+0.15/-0		22.8+0.15/-0		28.3+0.2/-0	
Dimensions [mm]	A	86		108		136	
	E	82		100		125	
	F	110		135		165	
	G	98		122		150	
	H	5.5		6.5		6.5	
	L	41.6	42.1	47	47.9	52.5	53.5
	M	40		46		49	
	P	1.6	2.1	1	1.9	3.5	4.5
T	2.1		2.4		2.4		
Weight [lbs / kg]		2.6 / 1.2		4.6 / 2.1		8.2 / 3.7	

[ Included parts & accessories : surge protector ]

[ 1 inch = 25.4 mm ]

[ Note 1 : Silent type ]

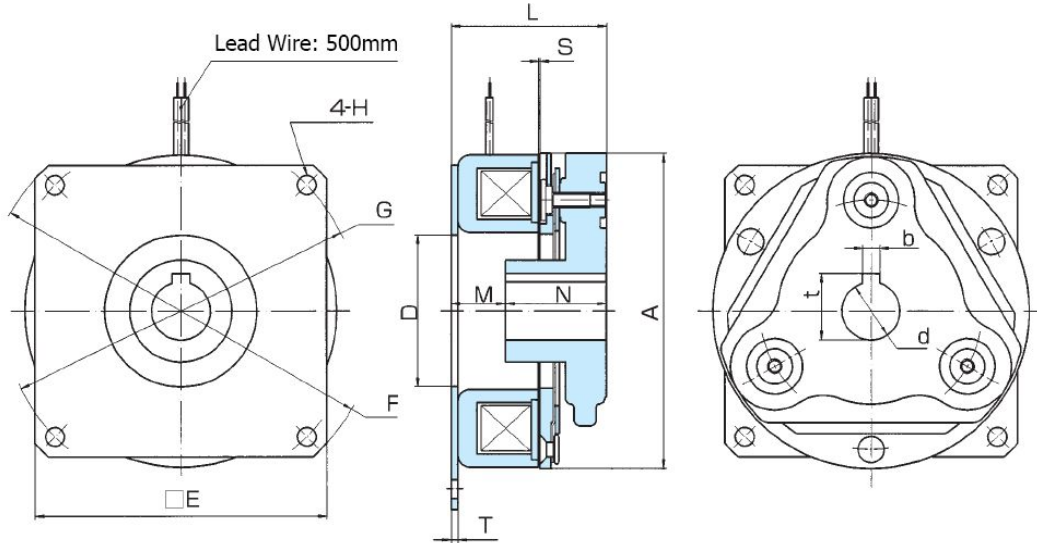

[ Special ]

[ Special ]

[ Special ]

VBEHA / VBSHA		1.2		2.5		5	
Type		VBEHA	VBSHA <sup>1</sup>	VBEHA	VBSHA <sup>1</sup>	VBEHA	VBSHA <sup>1</sup>
Static Torque [ft-lbs / N-m]		8.9 / 12		18 / 25		37 / 50	
Coil (20°C)	Voltage [DC-V]	24					
	Current [A]	0.75		0.92		1.41	
	Resistance [Ω]	32		26		17	
	Wattage [W]	18		22		33	
Armature	Pull-In Time [ms]	20		30		50	
	Release Time [ms]	40		40		50	
Torque Build-Up Time [ms]		50		70		100	
Max Allowable Speed [rpm]		5500		5000		4000	
Moment of Inertia (J) [kg-cm <sup>2</sup> ]		4.7		12		36	
Total Energy Until Life [J]		13 x 10 <sup>7</sup>		25 x 10 <sup>7</sup>		49 x 10 <sup>7</sup>	
Bore [mm]	dH7	15		20		25	
Key Way [mm]	bJs9	5		6		8	
	t	17.3+0.15/-0		22.8+0.15/-0		28.3+0.2/-0	
Dimensions [mm]	A	86		108		136	
	D+0.2/-0	45		52		65	
	E	82		100		125	
	F+0/-0.2	110		135		165	
	G	98		122		150	
	H	5.5		6.5		6.5	
	L	49.5	50.5	53.5	54.5	63.5	64.5
	M	23.5	24.5	18.5	19.5	21.5	22.5
	N	26		35		42	
	S	0.4		0.4		0.5	
T	2.1		2.4		2.4		
Weight [lbs / kg]		2.2 / 1.0		4.2 / 1.9		8.2 / 3.7	

[ Included parts & accessories : surge protector ]

[ 1 inch = 25.4 mm ]

[ Note 1 : Silent type ]

# VB: TYPICAL INSTALLATION

## One Piece Type

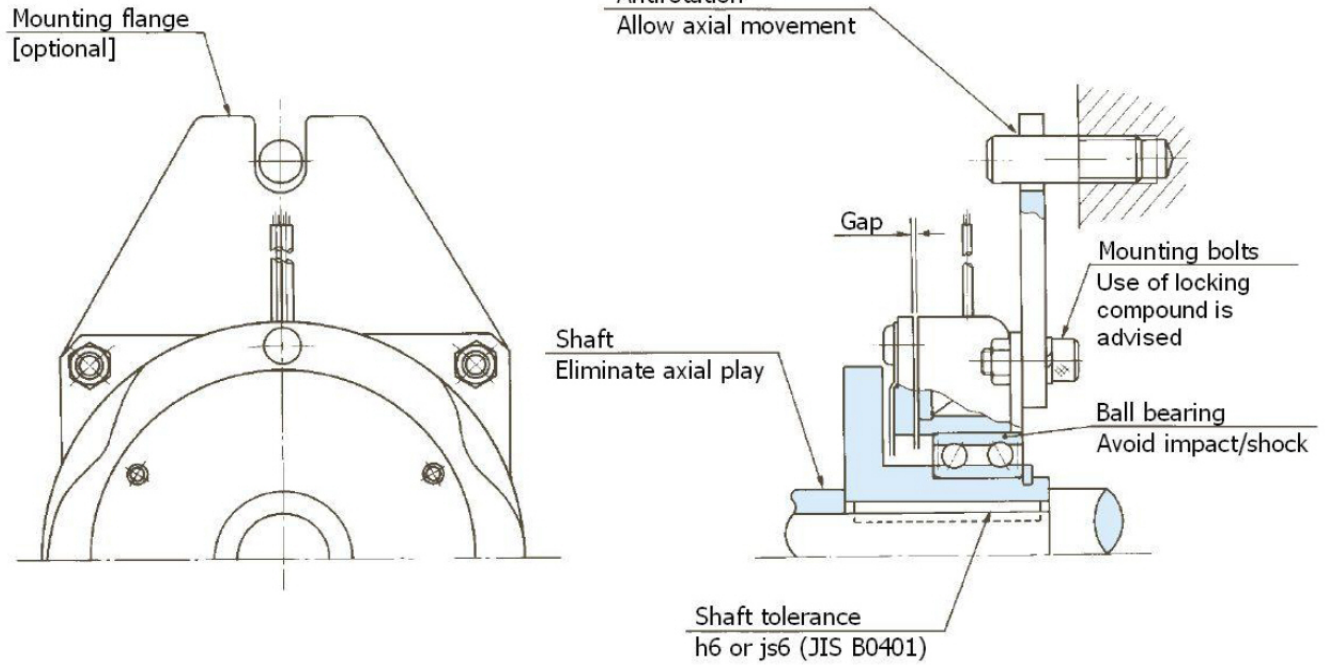

## Automatic Adjustment Type

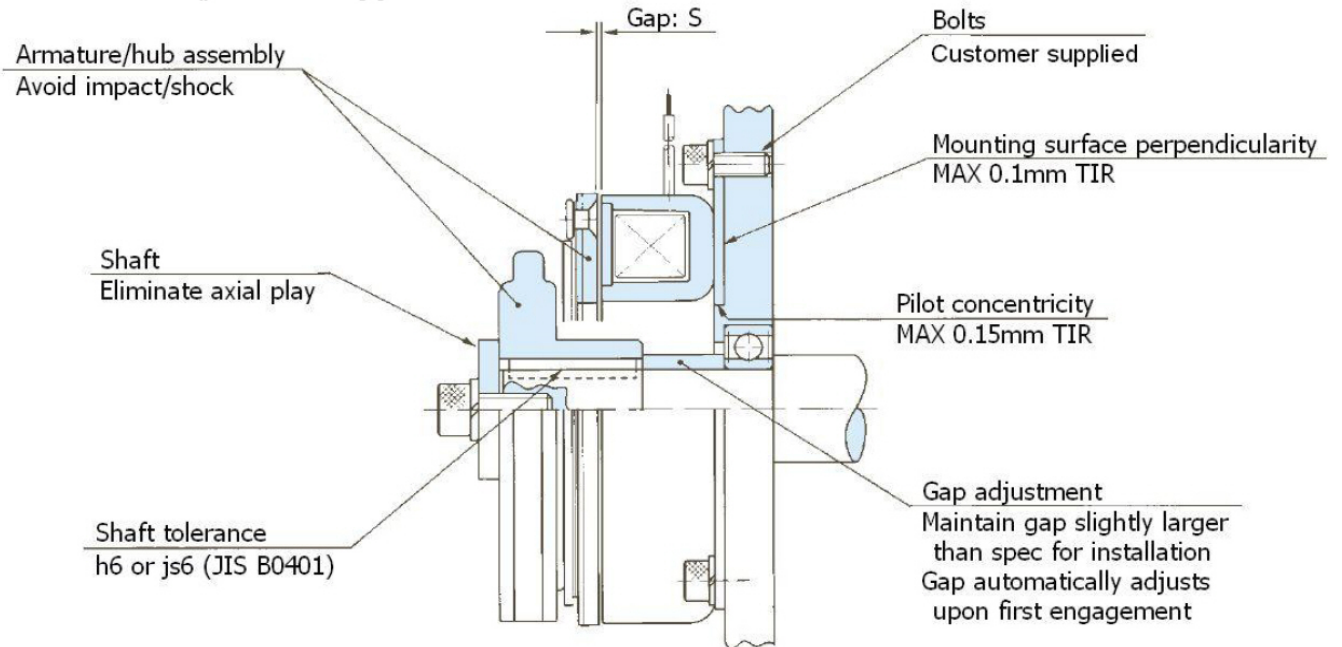

# VB: TYPICAL INSTALLATION

## Silent Type

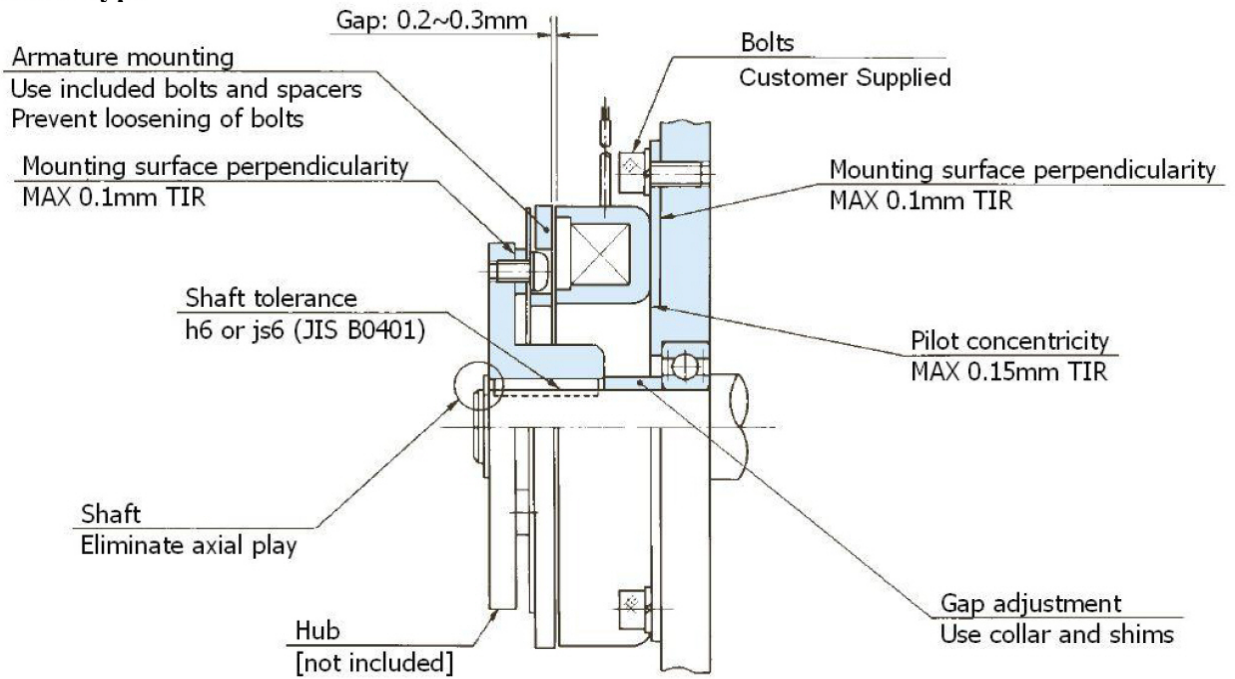

# VB: TORQUE CHARACTERISTIC & MAX WORK RATE

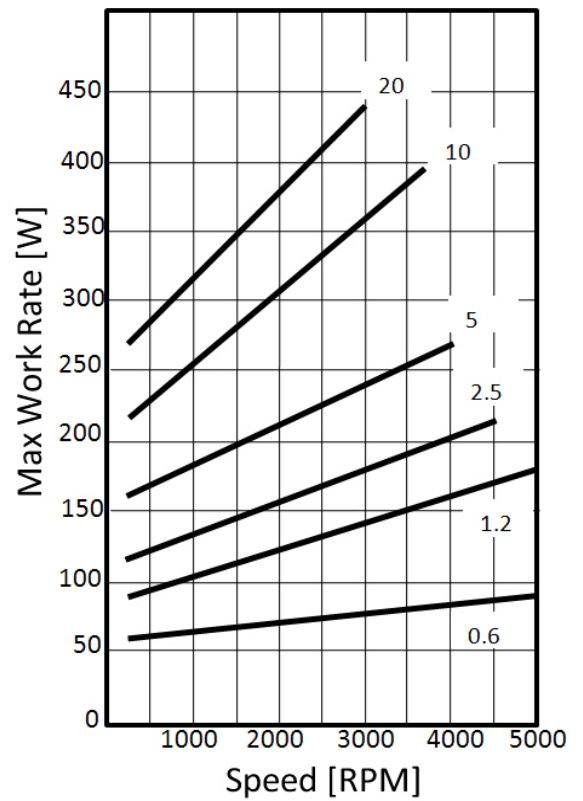
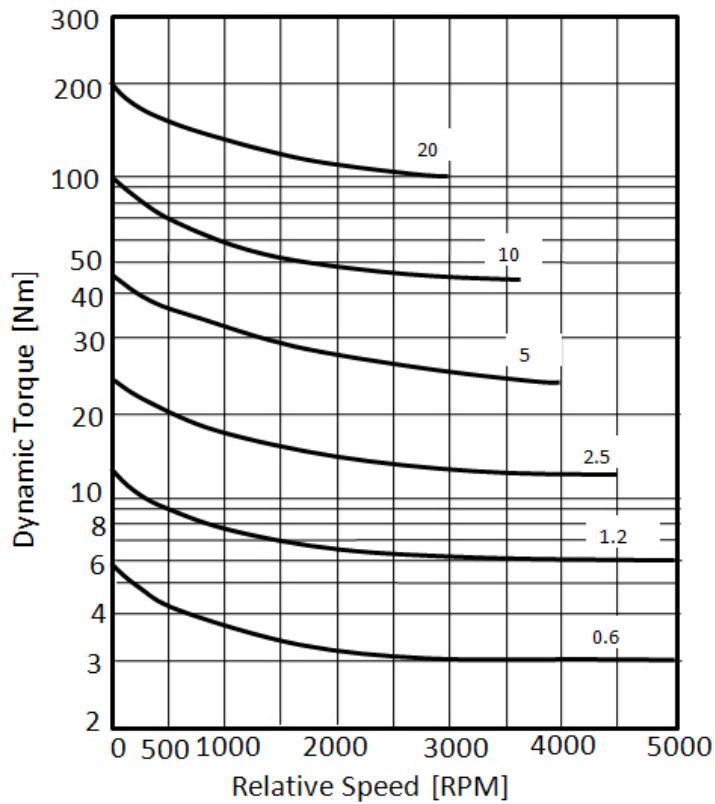

# VF

## Cooling Fan for V-Series Units

Types: 1.2, 2.5, 5

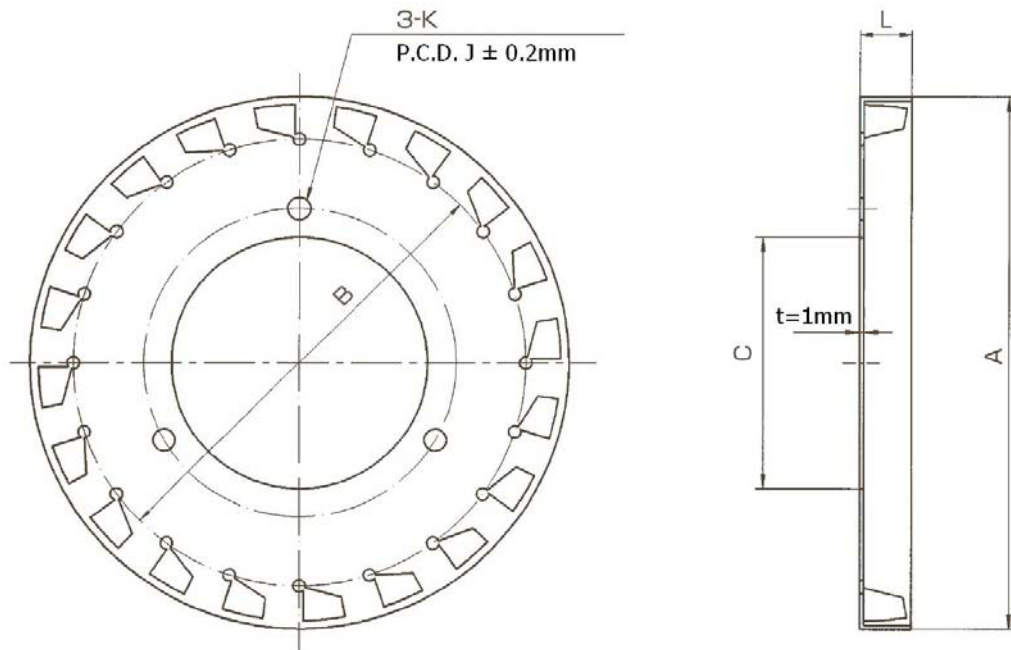

VF		1.2	2.5	5	
Max Allowable Speed [rpm]		2000	2000	2000	
Dimensions [mm]	A	108	131	164	
	B	88	110	138	
	C	50	62	76	
	K	4.5	5.5	6.5	
	J	60	76	95	
	L	11	13	16	
Applicable Units		VCE(H)	VCS(H)	VBE(H)	VBS(H)
Optional Units <sup>1</sup>		VCE(H)-P	VCS(H)-P	VCEHA	VCSHA
		VBE(H)-P	VBS(H)-P	VBEHA	VBSHA

[ Note 1 : Available as factory-mounted only ]

[ 1 inch = 25.4 mm ]

# B

## S E R I E S

### SELF-ADJUSTING ELECTROMAGNETIC BRAKE

Torque Range: 20 ~ 50 ft-lbs

Torque Range: 27 ~ 68 N-m



## FEATURES

### AUTOMATIC ADJUSTMENT FOR WEAR

The B series brakes include a patented adjusting mechanism for the armature that not only gives a constant adjustment for wear, but also produces a constant air gap on return. This gives a consistent armature engagement time over the life of the unit which is critical in some cycling applications.

### SMOOTH, QUIET OPERATION

Chattering noise between armature and hub spline is eliminated due to patented armature design which includes a rubber dampener to produce smooth, quiet operation.

### STAINLESS STEEL HUB

Stainless steel hubs break up residual magnetism (flux) at the hub, preventing the magnetism from being transmitted into the shaft. Stainless steel also has superior corrosion resistance which helps eliminate potential corrosion between the armature and the hub.

### HEAVY DUTY STANDARD DESIGN

Armature to hub connection is via heavy duty spline.

### EXCELLENT HEAT DISSIPATION

The design of flutes in the armature helps to dissipate the heat generated by friction on engagement.





# B

# Self-Adjusting EM Brake

Types: 20, 50

[ EM: Electromagnet ]

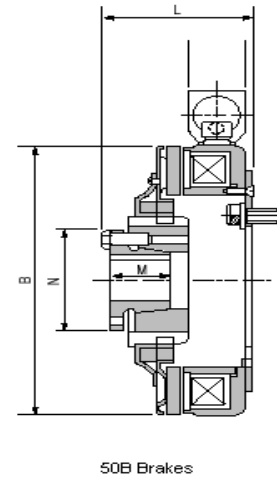
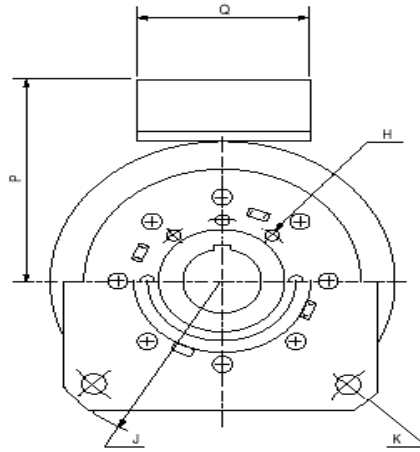
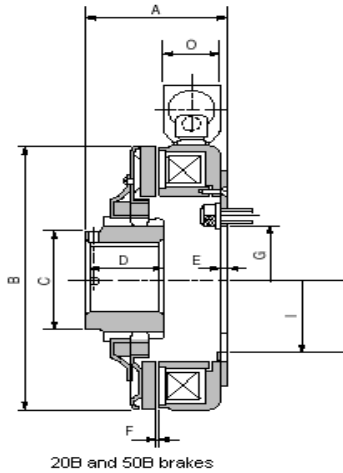

B		20	50
Rated Torque [ft-lbs / N-m]		20 / 27.1	50 / 67.8
Coil (20°C)	Voltage [DC-V]	90 <sup>1</sup> , 28, 6	90 <sup>1</sup> , 6
	Resistance [Ω]	1087	237
Max Allowable Speed [rpm]		4500	4000
Standard Bore Options [in]	Bore	1/2	1-1/8
	Key	1/8 x 1/16	1/4 x 1/8
	Bore	5/8	1-1/4
	Key	3/16 x 3/32	1/4 x 1/8
	Bore	3/4	Accepts Type G Bushing
Key	3/16 x 3/32		
Bore	7/8		
Dimensions [in]	Key	3/16 x 3/32	
	Bore	1	
	Key	1/4 x 1/8	
	A	2.219	2.406
	B	4.25	5.313
	C	1.594	1.969
	D	1.188	1.313
	E	0.094	0.125
	F	0.024	0.031
	G	1.874 / 1.873	2.065 / 2.063
	H (Qty)	-	8
	H (Bore)	-	0.187 / 0.181
	H (Depth)	-	2.875
	I	-	2.75
	J	5.625 / 5.623	6.500 / 6.498
	K	5	5.875
	L	-	2.627
	M	-	1
N	-	1.978 / 1.968	
O	-	1.25	
P	Terminal	4.150 <sub>Max</sub>	
Q	-	2.875	
Weight [lbs / kg]		4.0 / 1.8	6.2 / 2.8

[ Note 1 : Most common voltage ]

[ 1" = 25.4mm ]

# TMB

S E R I E S

## ELECTROMAGNETIC BRAKE [ZERO BACKLASH]

Torque Range: 4.4 ~ 148 ft-lbs

Torque Range: 6 ~ 200 N-m

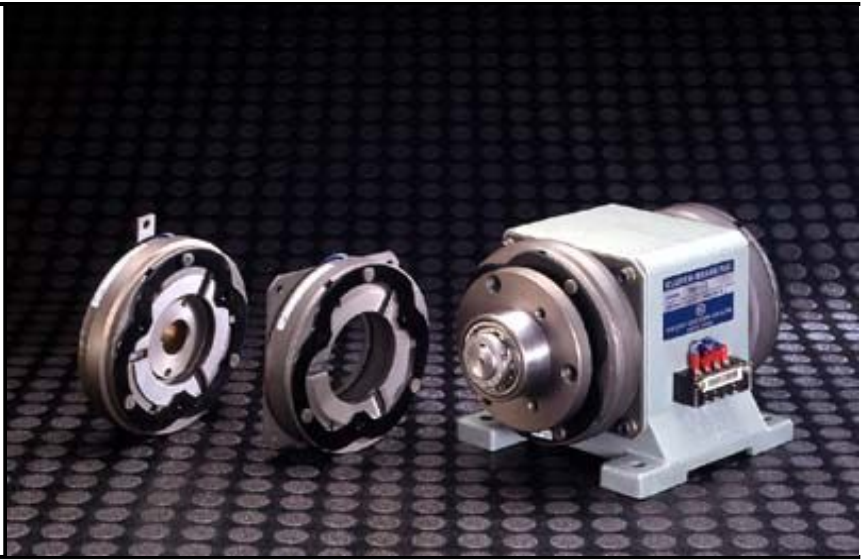

## FEATURES

### FAST RESPONSE

TM series brakes are dry type single disc units with no sliding parts. That means you can count on fast response time.

### NO BACKLASH ARMATURE

By mounting the armature to its hub by means of leaf springs, backlash is minimized and armature rattle is eliminated.

### COMPACT DESIGN

The compact design of the TM series reduces mounting requirements and makes installation a snap.

### MOUNTING FLEXIBILITY

The TM series can be provided with a flange mount or bearing mount design.

### LOW INERTIA

Fast response and low inertia are due to the TM series low weight and compact design.

TM BRAKES HAVE BEEN REPLACED BY THE V SERIES, ALTHOUGH SOME TM SERIES MAY STILL BE AVAILABLE  
PLEASE CHECK FOR AVAILABILITY



Model TMB-H Brake



Model TMB-HI Brake

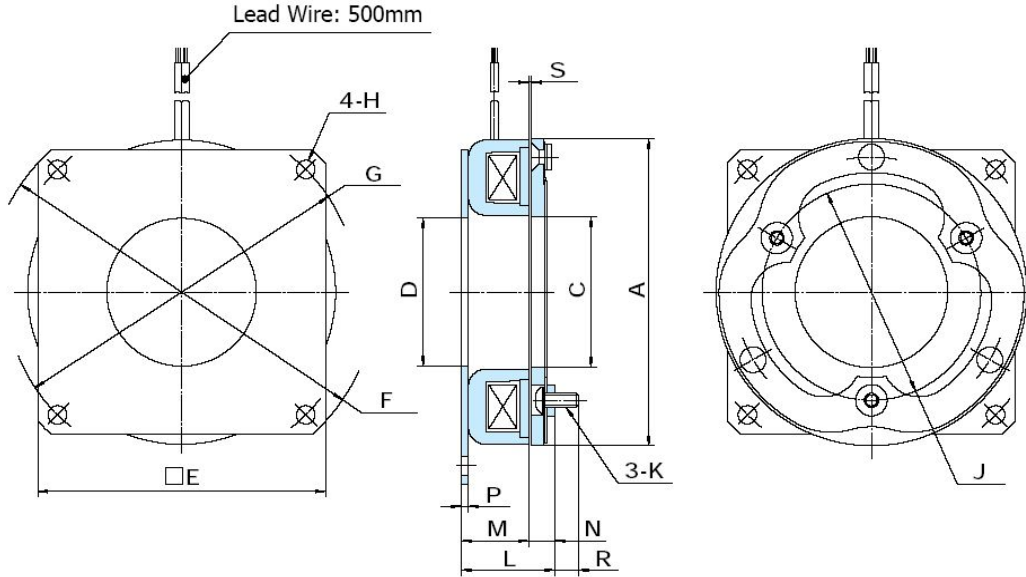

[ Special Order ]

TMB		0.6	1.2	2.5	5	10	20
Static Torque [ft-lbs / N-m]		4.4 / 6	8.9 / 12	18 / 24	37 / 50	74 / 100	148 / 200
Coil (20°C)	Voltage [DC-V]	24					
	Current [A]	0.5	0.65	0.92	1.35	1.6	2.2
	Resistance [Ω]	48	37	26	18	15	11
	Wattage [W]	12	15	22	33	38	53
Armature	Pull-In Time [ms]	10	16	16	25	40	55
	Release Time [ms]	10	10	24	25	35	62
Torque Build-Up Time [ms]		42	46	51	56	78	95
Max Allowable Speed [rpm]		5000	5000	4500	4000	3600	3000
Moment of Inertia (J) [kg-cm <sup>2</sup> ]		0.5	1.5	4.8	14	45	136
Max Air Gap Until Adjustment [mm]		0.5	0.6	0.7	0.8	1.2	1.5
Total Energy Until Adjustment [J]		2.9 x 10 <sup>7</sup>	6.6 x 10 <sup>7</sup>	13 x 10 <sup>7</sup>	26 x 10 <sup>7</sup>	62 x 10 <sup>7</sup>	120 x 10 <sup>7</sup>
Total Energy Until Life [J]		13 x 10 <sup>7</sup>	25 x 10 <sup>7</sup>	49 x 10 <sup>7</sup>	88 x 10 <sup>7</sup>	170 x 10 <sup>7</sup>	320 x 10 <sup>7</sup>
Dimensions [mm]	A	67	86	108	136	170	215
	C	35	45	53	66	83	107
	D+0.2/-0	35	45	52	65	80	107
	E	62	82	100	125	156	200
	F+0/-0.2	85	110	135	165	210	265
	G	75	98	122	150	190	240
	H	4.5	5.5	6.5	6.5	8.5	11
	J	46	60	76	95	120	158
	K	M3	M4	M5	M6	M8	M10
	L	24.5	27.5	31.5	35	40	47.5
	M	19.2	21.1	23.4	25.2	27.1	31.2
	N	5.3	6.4	8.1	9.8	12.9	16.3
	P	1.8	2.1	2.4	2.4	2.7	3
R	5.8	7	8.2	10.4	14	17.5	
S	0.2~0.3	0.2~0.3	0.2~0.3	0.2~0.3	0.3~0.4	0.4~0.5	
Weight [lbs / kg]		0.71 / 0.32	1.5 / 0.7	2.6 / 1.2	4.4 / 2.0	8.2 / 3.7	15 / 7

[ Included parts & accessories : bolts, washers, spacers, shims, surge protector ]

[ 1 inch = 25.4 mm ]

# TMB-H

## EM Brake (with hub)

Types: 0.6, 1.2, 2.5, 5, 10, 20

[ EM: Electromagnet ]

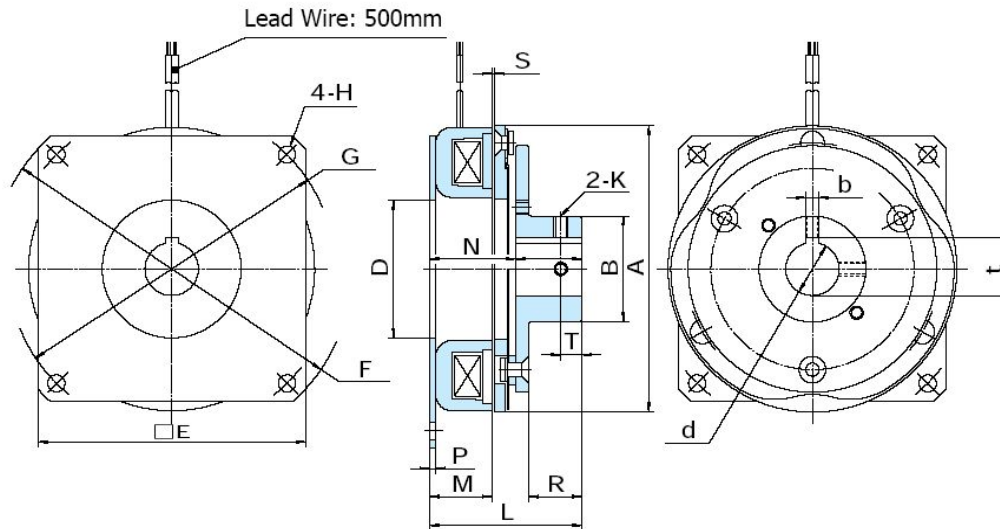

[ Special Order ]

TMB		0.6H	1.2H	2.5H	5H	10H	20H
Static Torque [ft-lbs / N-m]		4.4 / 6	8.9 / 12	18 / 24	37 / 50	74 / 100	148 / 200
Coil (20°C)	Voltage [DC-V]	24					
	Current [A]	0.5	0.65	0.92	1.35	1.6	2.2
	Resistance [Ω]	48	37	26	18	15	11
	Wattage [W]	12	15	22	33	38	53
Armature	Pull-In Time [ms]	10	16	16	25	40	55
	Release Time [ms]	10	10	24	25	35	62
Torque Build-Up Time [ms]		42	46	51	56	78	95
Max Allowable Speed [rpm]		5000	5000	4500	4000	3600	3000
Moment of Inertia (J) [kg-cm <sup>2</sup> ]		0.75	2.5	7.8	23	72	248
Max Air Gap Until Adjustment [mm]		0.5	0.6	0.7	0.8	1.2	1.5
Total Energy Until Adjustment [J]		2.9 x 10 <sup>7</sup>	6.6 x 10 <sup>7</sup>	13 x 10 <sup>7</sup>	26 x 10 <sup>7</sup>	62 x 10 <sup>7</sup>	120 x 10 <sup>7</sup>
Total Energy Until Life [J]		13 x 10 <sup>7</sup>	25 x 10 <sup>7</sup>	49 x 10 <sup>7</sup>	88 x 10 <sup>7</sup>	170 x 10 <sup>7</sup>	320 x 10 <sup>7</sup>
Bore [mm]	dH7	12	15	20	25	30	40
	bE9	4	5	5	7	7	10
Key Way [mm]	t+0.15/-0	13.5	17	22	28	33	43.5
	A	67	86	108	136	170	215
Dimensions [mm]	B	26	32	40	50	65	80
	D+0.2/-0	35	45	52	65	80	107
	E	62	82	100	125	156	200
	F+0/-0.2	85	110	135	165	210	265
	G	75	98	122	150	190	240
	H	4.5	5.5	6.5	6.5	8.5	11
	K	M4	M5	M5	M6	M8	M8
	L	39.5	47.5	56.5	65	80	97.5
	M	19.2	21.1	23.4	25.2	27.1	31.2
	N	24.5	27.5	31.5	35	40	47.5
	O	15	20	25	30	40	50
	P	1.8	2.1	2.4	2.4	2.7	3
	R	11.5	16	20	24	33	41
	S	0.2~0.3	0.2~0.3	0.2~0.3	0.2~0.3	0.3~0.4	0.4~0.5
	T	6	8	8	10	10	15
	Weight [lbs / kg]		0.9 / 0.4	2.0 / 0.9	3.5 / 1.6	6.0 / 2.7	11 / 5

[ Included parts & accessories : shims, surge protector ]

[ 1 inch = 25.4 mm ]

# TMB-HI

## EM Brake (with inverted hub)

Types: 0.6, 1.2, 2.5, 5, 10, 20

[ EM: Electromagnet ]

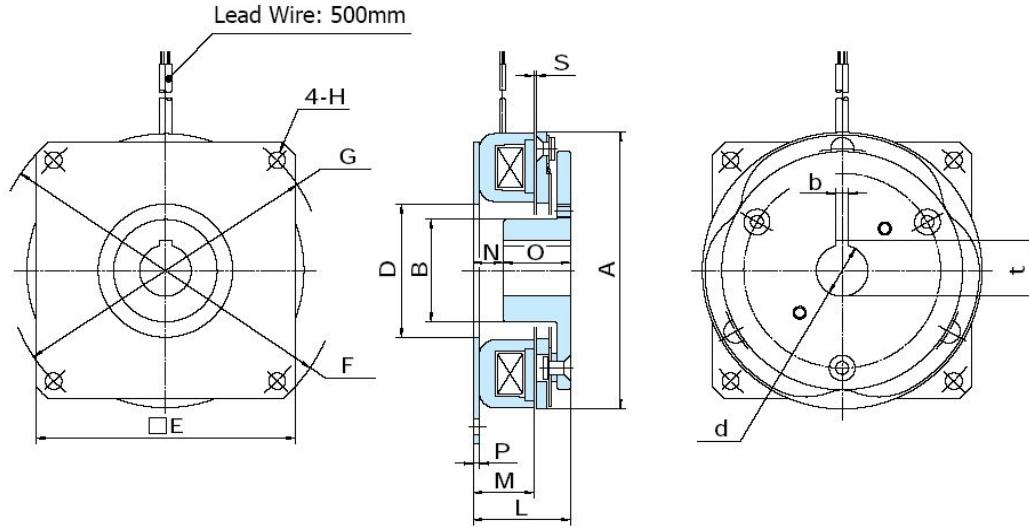

[ Special Order ]

TMB		0.6HI	1.2HI	2.5HI	5HI	10HI	20HI
Static Torque [ft-lbs / N-m]		4.4 / 6	8.9 / 12	18 / 24	37 / 50	74 / 100	148 / 200
Coil (20°C)	Voltage [DC-V]	24					
	Current [A]	0.5	0.65	0.92	1.35	1.6	2.2
	Resistance [ $\Omega$ ]	48	37	26	18	15	11
	Wattage [W]	12	15	22	33	38	53
Armature	Pull-In Time [ms]	10	16	16	25	40	55
	Release Time [ms]	10	10	24	25	35	62
Torque Build-Up Time [ms]		42	46	51	56	78	95
Max Allowable Speed [rpm]		5000	5000	4500	4000	3600	3000
Moment of Inertia (J) [kg-cm <sup>2</sup> ]		0.75	2.5	7.8	23	72	248
Max Air Gap Until Adjustment [mm]		0.5	0.6	0.7	0.8	1.2	1.5
Total Energy Until Adjustment [J]		$2.9 \times 10^7$	$6.6 \times 10^7$	$13 \times 10^7$	$26 \times 10^7$	$62 \times 10^7$	$120 \times 10^7$
Total Energy Until Life [J]		$13 \times 10^7$	$25 \times 10^7$	$49 \times 10^7$	$88 \times 10^7$	$170 \times 10^7$	$320 \times 10^7$
Bore [mm]	dH7	12	15	20	25	30	40
Key Way [mm]	bE9	4	5	5	7	7	10
	t+0.15/-0	13.5	17	22	28	33	43.5
Dimensions [mm]	A	67	86	108	136	170	215
	B	26	32	40	50	65	80
	D+0.2/-0	35	45	52	65	80	107
	E	62	82	100	125	156	200
	F+0/-0.2	85	110	135	165	210	265
	G	75	98	122	150	190	240
	H	4.5	5.5	6.5	6.5	8.5	11
	L	28	31.5	36.5	41	47	56.5
	M	19.2	21.1	23.4	25.2	27.1	31.2
	N	13	11.5	11.5	11	7	6.5
	O	15	20	25	30	40	50
	P	1.8	2.1	2.4	2.4	2.7	3
S	0.2~0.3	0.2~0.3	0.2~0.3	0.2~0.3	0.3~0.4	0.4~0.5	
Weight [lbs / kg]		0.9 / 0.4	2.0 / 0.9	3.5 / 1.6	6.0 / 2.7	11 / 5	21 / 10

[ Included parts & accessories : shims, surge protector ]

[ 1 inch = 25.4 mm ]

# TMB: TYPICAL INSTALLATION

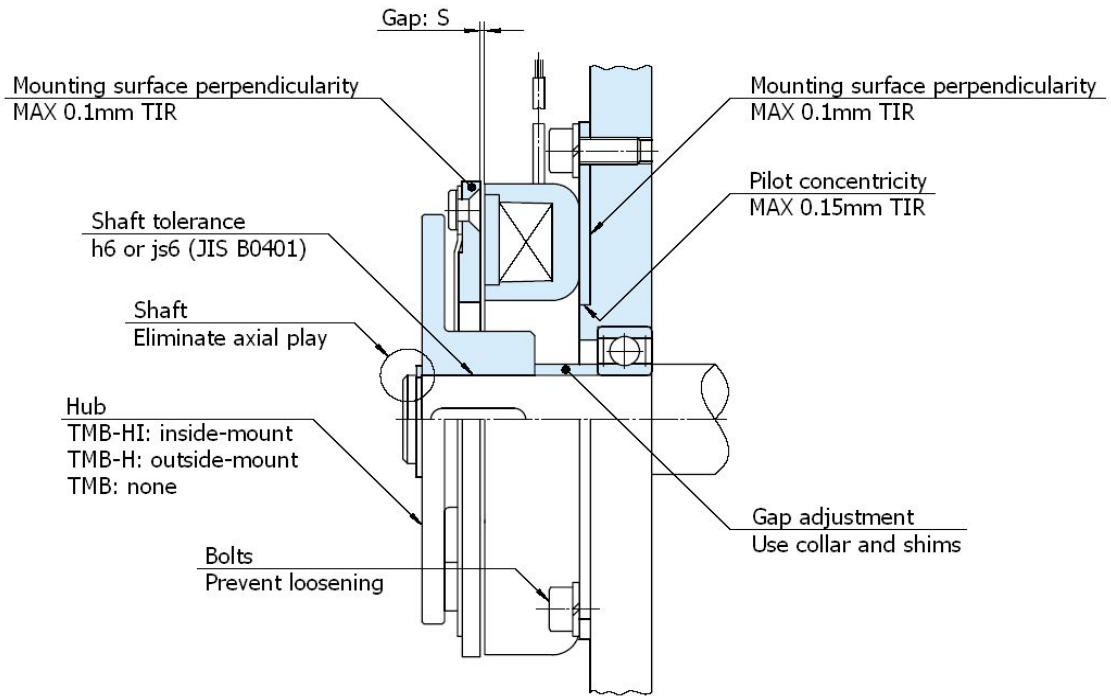

# TMB: TORQUE CHARACTERISTIC & MAX WORK RATE

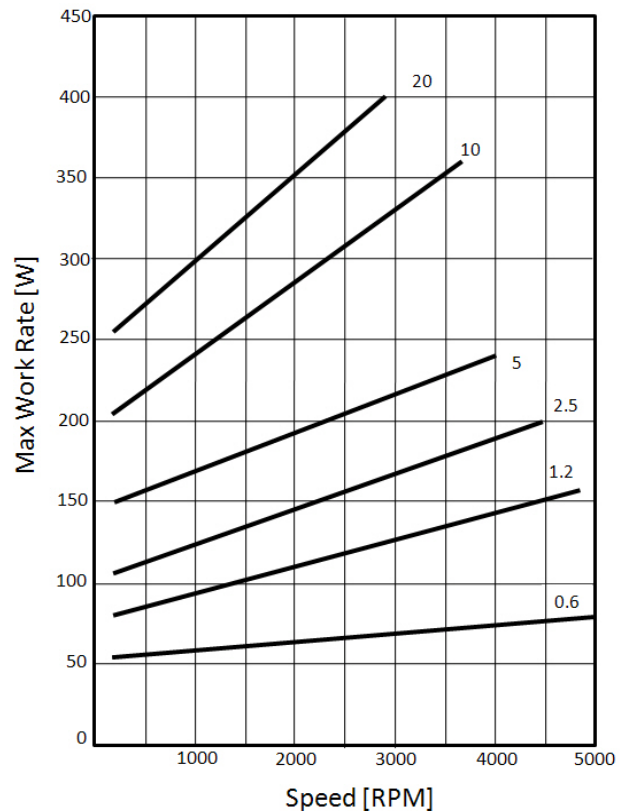
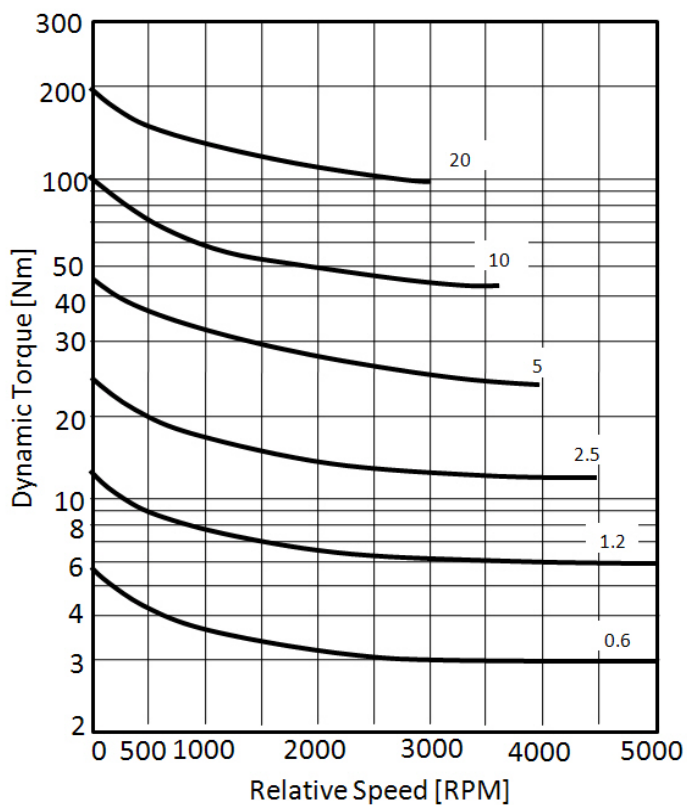



# MD

S E R I E S

## DRY-TYPE MULTIPLE-DISK ELECTROMAGNETIC CLUTCH & BRAKE

Torque Range: 13 ~ 6196 ft-lbs

Torque Range: 18 ~ 8400 N-m

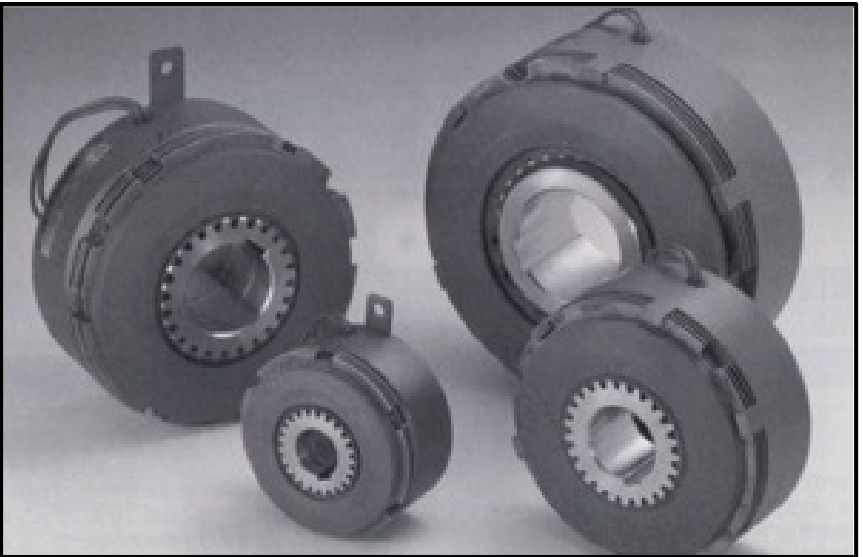

## FEATURES

### HIGH-TORQUE COMPACT DESIGN

The MD series are designed to produce very high torque in an overall compact design. Torque is produced via multiple disks condensing overall clutch size.

### QUICK RELEASE TIME

Separator springs between the friction plates allow for quick disconnect when the power is released. These springs also keep the disks from making contact with each other in the disengaged mode.

### FAST TORQUE BUILD-UP

Because of limited internal movement and via multiple disks, clutch torque can be generated very quickly.

### EASILY CONNECT TO YOUR GEAR PULLEY OR COUPLING

The MD series is made to be used with the UN drive cup, the cup slides between the friction disk tangs and has a tapped bolt pattern so you can attach your bearing mounted gear pulley.



MDC



MDB-N



UN Drive Cup

# MDB-N

## Dry-Type Multiple-Disk EM Brake

Types: 1.2, 2.5, 5, 10, 20, 40, 80

[ EM: Electromagnet ]

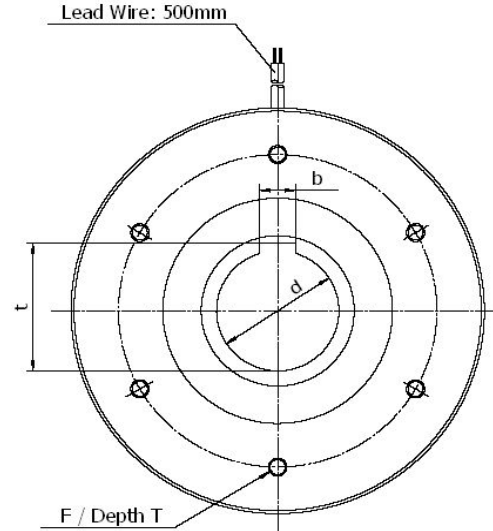
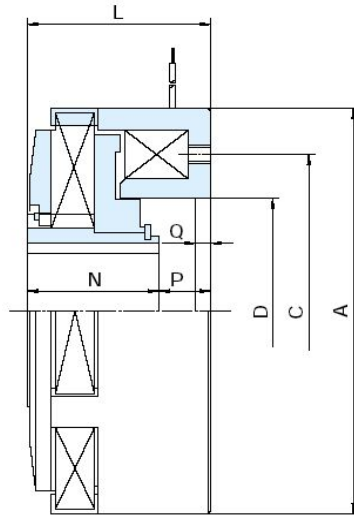

MDB		1.2N	2.5N	5N	10N	20N	40N	80N
Dynamic Torque [ft-lbs / N-m]		8.9 / 12	18 / 25	37 / 50	74 / 100	148 / 200	295 / 400	590 / 800
Static Torque [ft-lbs / N-m]		13 / 18	26 / 35	52 / 71	103 / 140	207 / 281	413 / 560	826 / 1120
Coil (20°C)	Voltage [DC-V]	24						
	Current [A]	0.62	0.8	1	1.46	1.75	2.5	3.12
	Resistance [Ω]	38.5	30	24	16.5	13.7	9.6	7.7
	Wattage [W]	15	19	24	35	42	60	75
Armature Pull-In Time [ms]		60	80	90	120	170	210	330
Torque Build-Up Time [ms]		105	160	180	200	290	360	520
Torque Decay Time [ms]		60	70	80	110	180	230	240
Max Work Rate [W]		7	11	23	42	65	97	153
Max Allowable Speed [rpm]		1800	1500	1200	1000	800	700	600
Moment of Inertia (J) [kg-cm <sup>2</sup> ]		3	6	14	34	61	249	715
Total Energy Until Life [J]		0.8 x 10 <sup>7</sup>	1.6 x 10 <sup>7</sup>	2.9 x 10 <sup>7</sup>	4.9 x 10 <sup>7</sup>	7.2 x 10 <sup>7</sup>	13.0 x 10 <sup>7</sup>	20.0 x 10 <sup>7</sup>
Max Work Rate [W]		7	11	23	42	65	97	153
Bore [mm]	dH7	20	25	30	40	50	60	70
Key Way [mm]	bE9	6	8	8	12	14	18	20
	t+0.2/-0	21.7	26.7	32	42.5	52.5	63	75
Dimensions [mm]	A	82	97	114	135	157	197	237
	C	62	74	86	104	126	156	190
	DH8	42	50	58	75	92	106	128
	F	4xM5	4xM6	4xM6	6xM6	6xM8	6xM10	6xM12
	L	45	48	55	60	68	76	96
	N	28	30	34	43	50	62	82
	P±0.3	17	18	21	17	18	14	14
	Q	4	4	5	5	6	8	8
T	5	6	6	6	8	10	12	
Weight [lbs / kg]		2.9 / 1.3	3.7 / 1.7	5.7 / 2.6	8.8 / 4.0	14 / 6.4	26 / 12	49 / 22

[ Included parts & accessories : surge protector ]

[ 1" = 25.4mm ]

# MDB: TYPICAL INSTALLATION

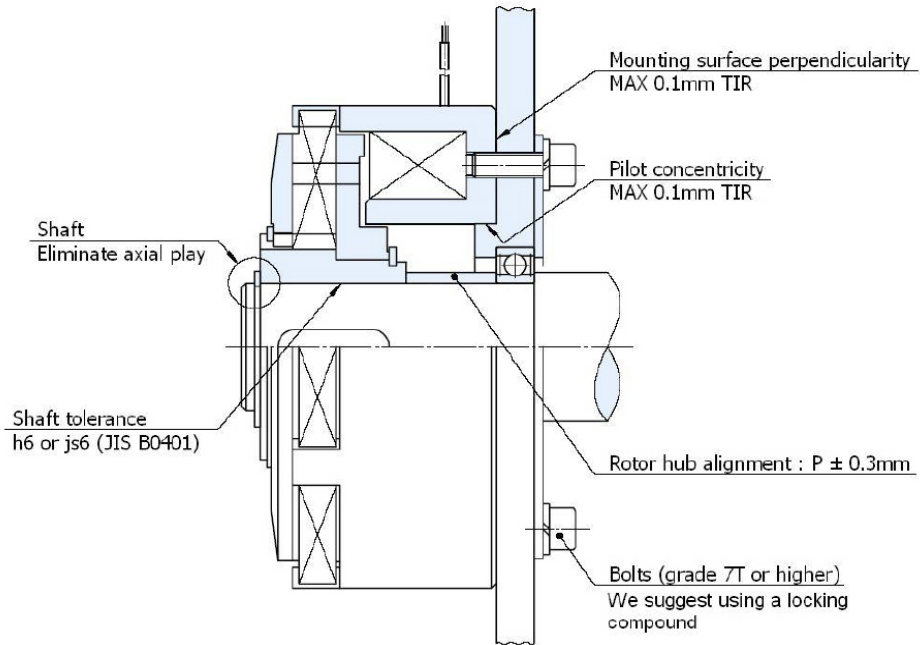

# MDB: MAX ENGAGEMENT ENERGY

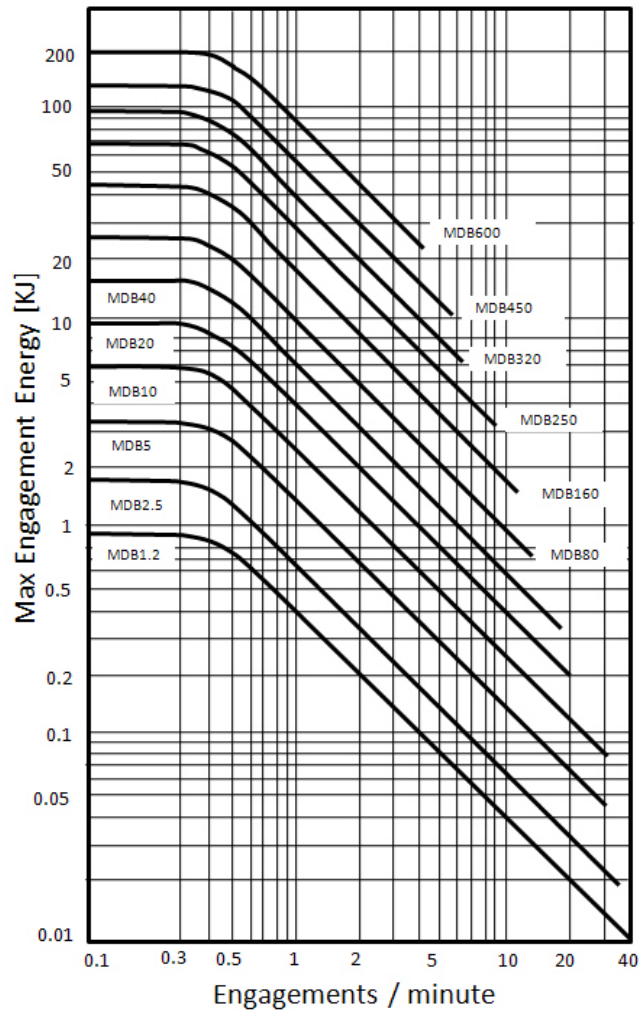

# MW

S E R I E S

## WET-TYPE MULTIPLE-DISK ELECTROMAGNETIC CLUTCH & BRAKE

Torque Range: 18 ~ 8851 ft-lbs

Torque Range: 25 ~ 12000 N-m



## FEATURES

### HIGH-TORQUE COMPACT DESIGN

The MW series are designed as extremely compact multiple disc units that deliver high torque rates.

### LONG LIFE AND LOW MAINTENANCE

The MW series stationary field design and oil lubrication system significantly reduce wear and maintenance while increasing operational life.

### QUICK RELEASE TIME

Separator springs between the friction plates allow for quick disconnect when the power is released. These springs also keep the disks from making contact with each other in the disengaged mode.

### FAST TORQUE BUILD-UP

An efficiently etched oil path on the friction disk, coupled with special treatment of the friction disks ensures fast response and release time.

### HIGH HEAT DISSIPATION

The oil lubrication system provides excellent heat dissipation making the MW series suitable for heavy duty operation.

### EASILY CONNECT TO YOUR GEAR PULLEY OR COUPLING

The MD series is made to be used with the UN drive cup, the cup slides between the friction disk tangs and has a tapped bolt pattern so you can attach your bearing mounted gear pulley.



MWC



MWB



UN Drive Cup

# MWB

## Wet-Type Multiple-Disk EM Brake

Types: 1.2, 2.5, 5, 10, 20, 40, 80, 160

[ EM: Electromagnet ]

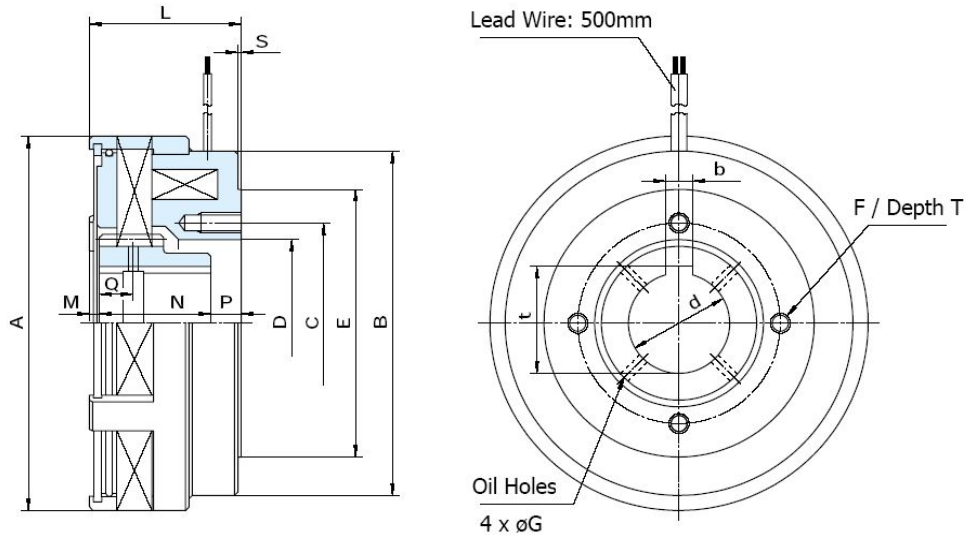

[ Special Order ]

MWB		1.2	2.5	5	10	20	40	80	160	
Dynamic Torque [ft-lbs / N-m]		8.9 / 12	18 / 25	37 / 50	74 / 100	148 / 200	295 / 400	590 / 800	1180 / 1600	
Static Torque [ft-lbs / N-m]		18 / 24	37 / 50	74 / 100	148 / 200	295 / 400	590 / 800	1180 / 1600	2360 / 3200	
Coil (20°C)	Voltage [DC-V]	24								
	Current [A]	0.33	0.5	0.75	1	1.3	1.4	1.8	4.1	
	Resistance [Ω]	72	48	32	24	19	17	13.5	5.8	
	Wattage [W]	8	12	18	24	31	36	45	100	
Armature Pull-In Time [ms]		50	60	70	80	100	150	250	380	
Torque Build-Up Time [ms]		120	150	170	180	200	320	600	700	
Torque Decay Time [ms]		40	50	80	100	120	150	400	1000	
Max Allowable Speed [rpm]		4000	3600	3200	3000	2800	2400	2000	1600	
Moment of Inertia (J) [kg-cm <sup>2</sup> ]		0.5	1	3.3	9.5	19	56	193	520	
Bore [mm]		dH7	20	25	30	40	50	60	70	90
Key Way [mm]		bE9	6	8	8	12	14	18	20	25
		t+0.2/-0	21.7	26.7	32	42.5	52.5	63	75	95
Dimensions [mm]		A	80	95	112	132	157	198	238	290
		B	73	87	103	122	142	180	218	262
		C	42	50	60	70	90	110	144	174
		DH7	32	40	50	56	75	90	120	150
		E	-	-	80	95	110	130	160	200
		F	4xM5	4xM6	4xM6	4xM8	4xM8	4xM10	4xM10	6xM12
		G	2	3	3	3	3	4	4	4
		L	30	37	45	52	53	71	77.5	100
		M	3.5	4	3	4	5	6	8.5	11
		N	23	27	33	35	36	48	50	68
		P	3.5	6	9	13	12	17	19	21
		Q	7	8.5	10	13	13	16	19	22
Weight [lbs / kg]		1.5 / 0.7	2.9 / 1.3	4.4 / 2.0	7.3 / 3.3	9.9 / 5.0	22 / 10	42 / 19	73 / 33	

[ Included parts & accessories : surge protector ]

[ 1" = 25.4mm ]

# MWB: TYPICAL INSTALLATION

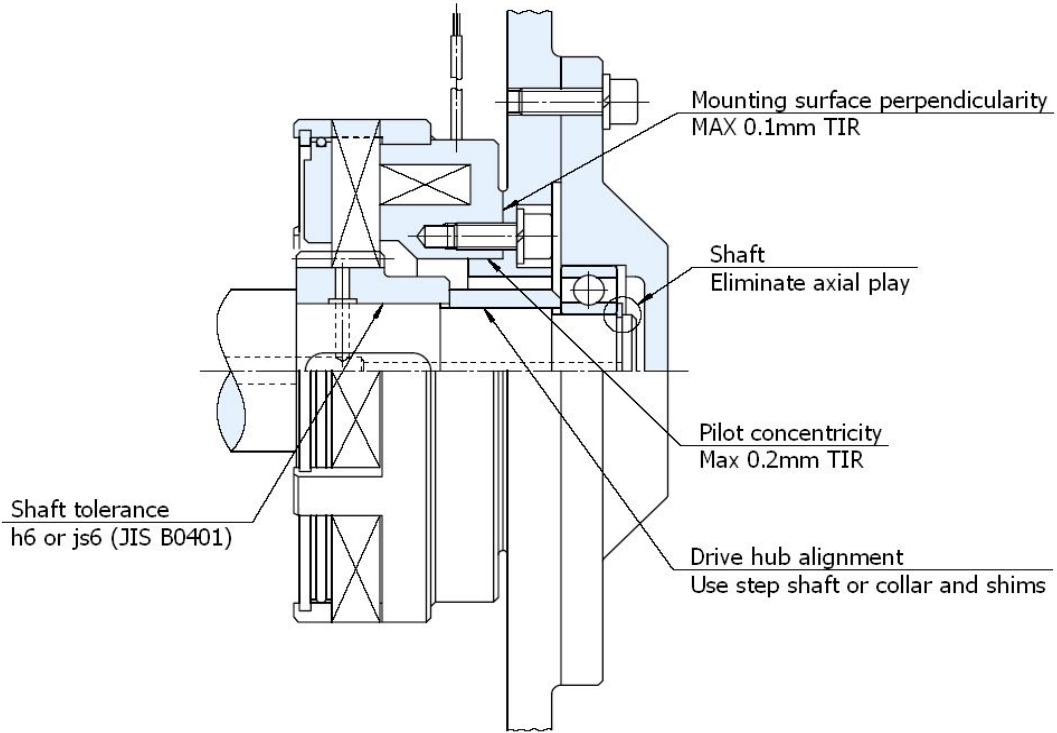

# MWB: MAX ENGAGEMENT ENERGY & DRAG TORQUE

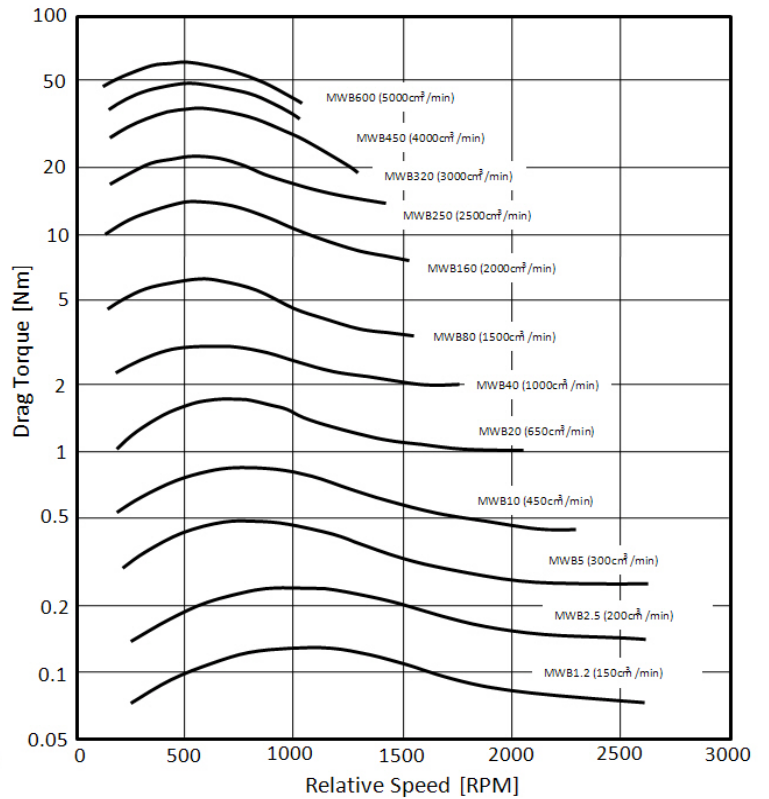
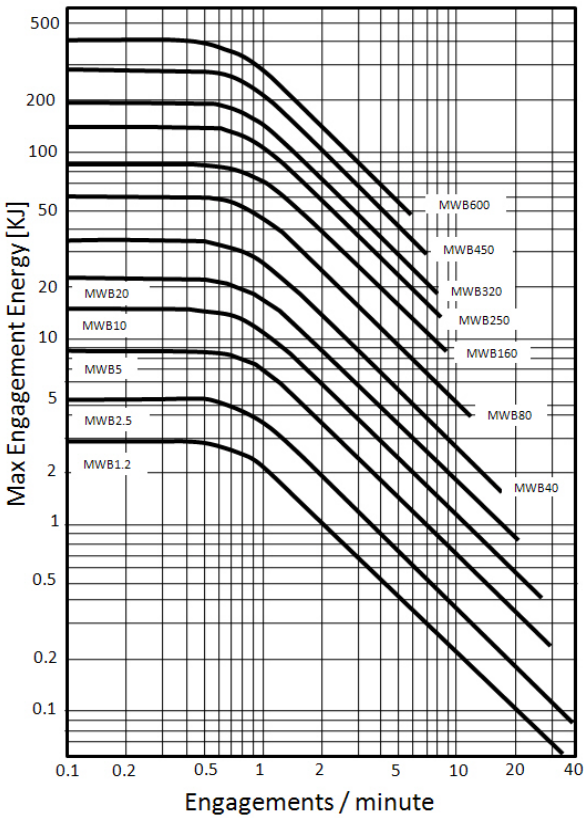



# AMU-C

S E R I E S

## ELECTROMAGNETIC CLUTCH & BRAKE

Torque Range: 2.2 ~ 71 in-lbs

Torque Range: 0.25 ~ 8 N-m



## FEATURES

### EASY MOUNTING AND MAINTENANCE

The clutch/brake units are preassembled. No adjustments are necessary, simply attach your pulley or coupling to the output shaft and you are ready to go.

### ZERO BACKLASH

By mounting the armature to the hub via leaf springs, backlash is minimized and armature rattle is eliminated.

### CONTROLLABLE RESPONSE TIME

Variations in acceleration or deceleration times and slip torque can be achieved by controlling the applied current.

### FAST RESPONSE

Elimination of splines provides faster response and high performance by overcoming friction in the armature and hub.

### HIGH HEAT DISSIPATION

The AM series units perform relentlessly year after year, even in heavy duty applications, due to their excellent heat dissipation.

### GOOD OVERHUNG LOAD CAPACITY

Four bearings (two on the bore input and output) provide excellent overhung load capacity.



AMU-C

# AMU-C

## Micro EM Clutch/Brake Unit

Types: 2.5, 5, 10, 20, 40, 80

[ EM: Electromagnet ]

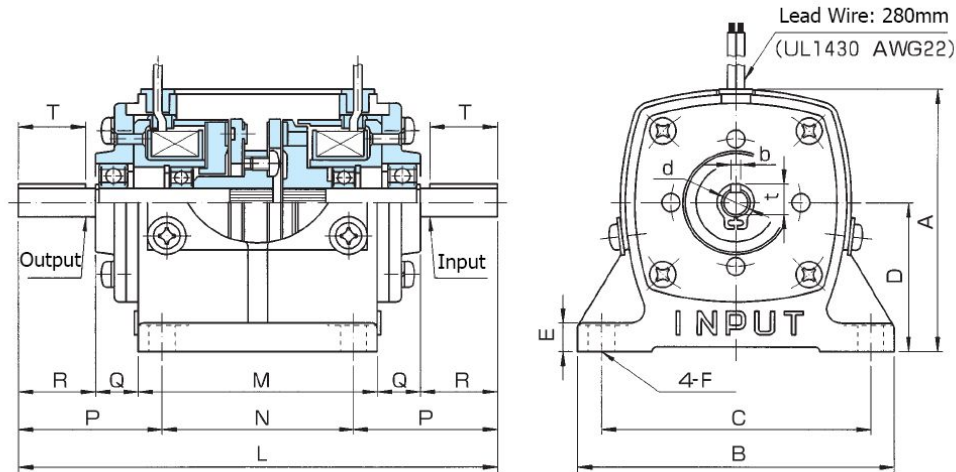

AMU		2.5C	5C	10C	20C	40C	80C
Static Torque [in-lbs / N-m]		2.2 / 0.25	4.4 / 0.5	8.9 / 1	18 / 2	35 / 4	71 / 8
Voltage [DC-V]		24					
Max Overhanging Load <sup>1</sup> [lbs / N]		27 / 120	27 / 120	43 / 190	65 / 290	79 / 350	92 / 410
Moment of Inertia (J) [kg-cm <sup>2</sup> ]	Rotor	0.05	0.068	0.148	0.29	0.718	1.3
	Armature	0.063	0.113	0.208	0.39	1.04	2.19
Shaft [mm]	dh7	6	6	8	10	12	15
Key [mm]	bh8	2	2	2.5	4	4	5
	t+0/-0.15	6.9	6.9	8.9	11.5	13.5	17
Dimensions [mm]	A	54.5	61.5	69	77	93	105
	B	66	72	84	90	106	120
	C	56	62	70	78	90	100
	D	31.5	35.5	40	45	56	63
	E	6	7	9	10	11	12
	F	5.5	5.5	6.5	6.5	8.5	8.5
	L	100	100	124	139	166	174
	M	50	50	62	69	80	86
	N	40	40	45	50	60	70
	P	30	30	39.5	44.5	53	52
	Q	9	9	11	12	13	14
R	16	16	20	23	30	30	
T	14	14	18	20	20	25	
Weight [lbs / kg]		0.9 / 0.4	1.2 / 0.5	2 / 0.9	3.3 / 1.5	4.6 / 2.1	6.3 / 2.9

[ Note 1 : At shaft midpoint; based on 600rpm/6000hr application ]

[ 1" = 25.4mm ]

# VSAU

## ELECTROMAGNETIC CLUTCH/BRAKE

Torque Range: 8.9 ~ 37 ft-lbs

Torque Range: 12 ~ 50 N-m



## FEATURES

### FAST RESPONSE

The V series brakes are dry type single disc units. This ensures fast response in high speed, high cycle applications.

### ZERO BACKLASH

The armature is mounted to the hub by special leaf springs to provide minimal backlash and no armature rattle.

### EASY MOUNTING

The clutch and brake are mounted in one housing. A simple connection to the input or the output shaft with a pulley or coupling is all that is required.

### TOTALLY ENCLOSED

To reduce the chance of contamination to the clutch or brake. Also, a housing will reduce the chance of wear particles from the clutch or brake. Thin housing helps cool the unit in demanding applications.



VSAU

# VSAU

## Self-Adjusting EM Clutch/Brake Unit

Types: 1.2, 2.5, 5

[ EM: Electromagnet ]

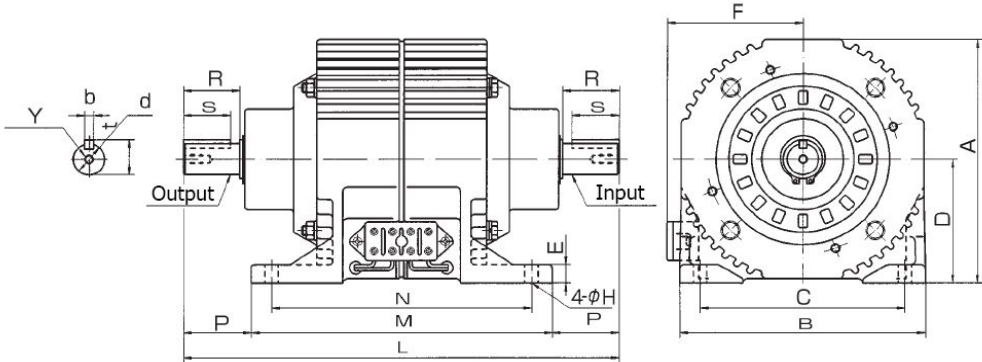

VSAU		1.2	2.5	5
Static Torque [ft-lbs / N-m]		8.9 / 12	18 / 25	37 / 50
Voltage [DC-V]		24		
Max Overhanging Load <sup>1</sup> [lbs / N]		146 / 650	146 / 650	193 / 860
Moment of Inertia (J) [kg-cm <sup>2</sup> ]	Input	2.8	8.7	25
	Output	7.8	21.3	64
Bore [mm]		dh7	20	25
Key Way [mm]	bh9	5	6	8
	t+0/-0.2	17	22.5	28
Dimensions [mm]	A	126	157	197
	B	136	156	190
	C	110	130	160
	D	63	80	102
	E	10	12	15
	F	78	86	102
	H	8.5	8.5	11
	L	244	277	320
	M	176	191	220
	N	150	165	190
	P	34	43	50
	R	27	36	45
S	25	30	40	
Y	M5x10	M6x12	M8x16	
Weight [lbs / kg]		11 / 5	18 / 8	32 / 15

[ Included parts & accessories : surge protector ]

[ 1 inch = 25.4 mm ]

[ Note 1 : At shaft midpoint; based on 1000rpm/10000hr application ]

# MP

S E R I E S

## ELECTROMAGNETIC CLUTCH/BRAKE UNIT

Torque Range: 4.4 ~ 443 in-lbs

Torque Range: 0.5 ~ 50 N-m



## FEATURES

### NO ADJUSTMENT FOR WEAR

Special armature and hub design allow for automatic wear adjustment.

### CONSISTENT TIMING

Special no-gap armature design produces consistent time-to-speed and time-to-stop over the life of the unit.

### FAST RESPONSE

Special coil and armature design allow for extremely fast response time.

### HIGH HEAT DISSIPATION

Fins on the outer housing in small units and the location of the internal clutch and brake provide maximum heat transfer for optimum cooling.

### LONGER LIFE VERSIONS AVAILABLE

Standard components allow for long cycle life. Optional friction material, such as ceramic, are available to further enhance cycle life.



MP 5 ~ 80



MP 120 ~ 500

# MP

## Micro EM Clutch/Brake Unit

Types: 5, 10, 20, 40, 80

[ EM: Electromagnet ]

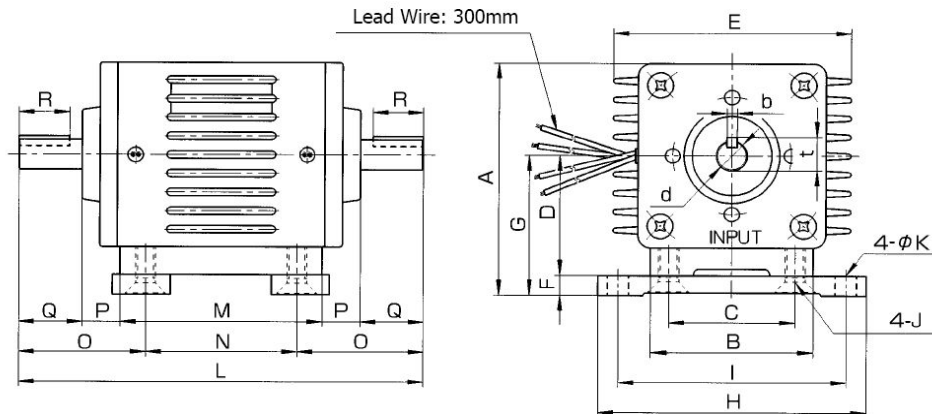

MP		5	10	20	40	80
Static Torque [in-lbs / N-m]		4.4 / 0.5	8.9 / 1	18 / 2	35 / 4	71 / 8
Coil (20°C)	Voltage [DC-V]	0.75	1.05	1.4	1.65	2.4
	Current [A]	5*				
	Resistance [Ω]	0.15	0.21	0.28	0.33	0.48
	Wattage [W]	3.8	5.3	7	8.3	12
Max Work Rate [W]		3.8	4.8	5.7	8.2	14
Max Allowable Speed [rpm]		2000	2000	2000	1500	1500
Max Overhanging Load <sup>1</sup> [lbs / N]		21 / 92	43 / 190	56 / 250	76 / 340	81 / 360
Moment of Inertia (J) [kg-cm <sup>2</sup> ]	Input	0.068	0.148	0.29	0.718	1.3
	Output	0.125	0.2	0.45	0.8	2
Max Wear Volume [cm <sup>3</sup> ]		0.57	0.75	1.2	2.2	3.7
Max Work Rate [W]		3.8	4.8	5.7	8.2	14
Bore [mm]	dh7	6	8	10	12	15
Key Way [mm]	bh8	2	2.5	4	4	5
	t+0/-0.15	6.9	8.9	11.5	13.5	17
Dimensions [mm]	A	61.5	69	77	93	105
	B	42	48	55	64	75
	C	32	35	40	50	60
	D	30.5	35	40	48	55
	E	64	74	84	94	104
	F	5	5	5	8	8
	G	35.5	40	45	56	63
	H	72	84	90	106	120
	I	62	70	78	90	100
	J	M5	M6	M6	M8	M8
	K	5.5	6.5	6.5	8.5	8.5
	L	100	124	139	166	194
	M	50	62	69	80	86
	N	40	45	50	60	70
O	30	39.5	44.5	53	62	
P	9	11	12	13	14	
Q	16	20	23	30	40	
R	14	18	20	20	35	
Weight [lbs / kg]		1.2 / 0.5	2 / 0.9	3.3 / 1.5	4.6 / 2.1	6.4 / 2.9

[ Note 1 : At shaft midpoint; based on 600rpm/6000hr application ]

[ 1" = 25.4mm ]

\* Coil voltage varies per unit size. A special power supply is required because of the special low voltage coils that are used to achieve over-excitation in these units.



# MP

## EM Clutch/Brake Unit

Types: 120, 250, 500

[ EM: Electromagnet ]

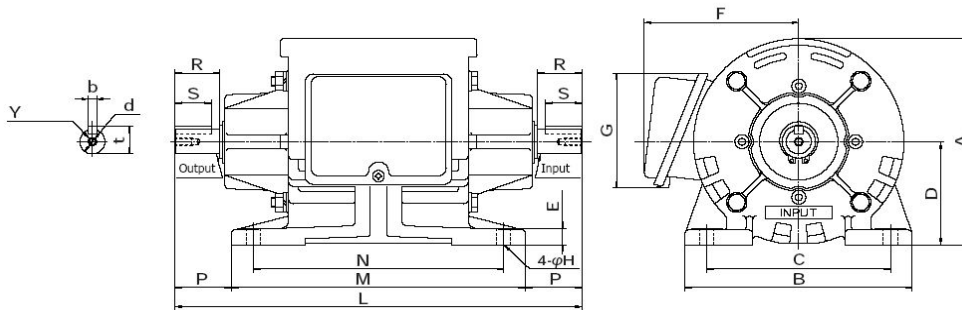

MP		120	250	500
Static Torque [in-lbs / N-m]		106 / 12	221 / 25	443 / 50
Coil (20°C)	Voltage [DC-V]	5.04	5.15	5.22
	Current [A]	3*	5*	6*
	Resistance [Ω]	1.68	1.03	0.87
	Wattage [W]	15	25	30
Max Work Rate [W]		23	38	49
Max Allowable Speed [rpm]		1500	1000	1000
Max Overhanging Load <sup>1</sup> [lbs / N]		173 / 770	173 / 770	225 / 1000
Moment of Inertia (J) [kg-cm <sup>2</sup> ]	Input	3.5	9.25	24.2
	Output	6.25	16.7	49
Max Wear Volume [cm <sup>3</sup> ]		6	11	22.5
Max Work Rate [W]		23	38	49
Bore [mm]	dh7	15	20	25
Key Way [mm]	bh8	5	5	7
	t+0/-0.20	17	22	28
Dimensions [mm]	A	126	157	197
	B	136	156	190
	C	110	130	160
	D	63	80	102
	E	10	12	15
	F	98	112	130
	G	71	71	71
	H	8.5	8.5	11
	L	244	277	320
	M	176	191	220
	N	150	165	190
	P	34	43	50
	R	27	36	45
	S	22	31	40
	Y	M5-10	M6-12	M8-16
Weight [lbs / kg]		11 / 5	18 / 8	33 / 15

[ Note 1 : At shaft midpoint; based on 600rpm/10000hr application ]

[ 1" = 25.4mm ]

\* Coil voltage varies per unit size. A special power supply is required because of the special low voltage coils that are used to achieve over-excitation in these units.

# MP: TORQUE CHARACTERISTIC

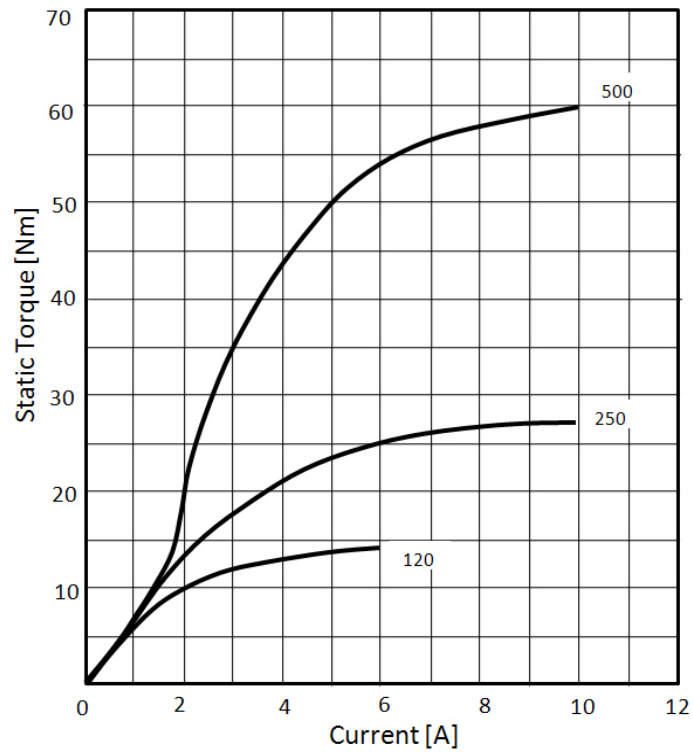
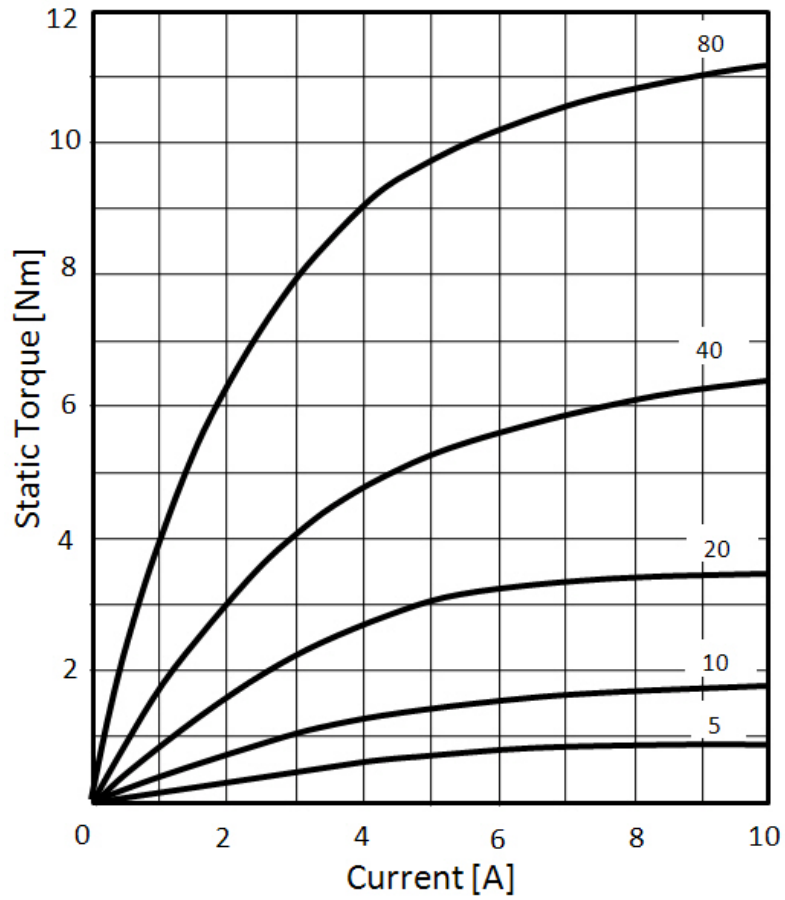

# MCNB

S E R I E S

## MICRO ELECTROMAGNETIC SPRING-APPLIED BRAKE

Torque Range: 1.8in-lbs ~ 8.9 in-lbs

Torque Range: 0.2 ~ 1 N-m



## FEATURES

### 100% RATED TORQUE

You can count on getting the rated torque for holding applications right out of the box.

### LONGEVITY

Wear-resistant friction material and corrosion resistant surfaces provide extended operational life.

### VOLTAGES AVAILABLE

The MCNB series brake is available in 24VDC, 45VDC or 90VDC. (The 45VDC type can be used with half-wave rectification of 100VAC).

### NON-ASBESTOS FRICTION MATERIAL

The MCNB series utilize non-asbestos friction discs, complying with current asbestos related safety regulations.

### HIGH RELIABILITY

Corrosion resistant stainless steel disc plate provides reliable operation.

### TWO BORE TYPES OFFERED

In the new series a standard D cut metric bore is available. This is a plastic molder hub with an anti rattle feature.

In the older version a standard machine bore is available in both inch and metric dimensions with two set screws.



MCNB [new]



MCNB [old]

# MCNB

## Micro EM Spring-Applied Brake

Types: 2, 5, 10

[ EM: Electromagnet ]

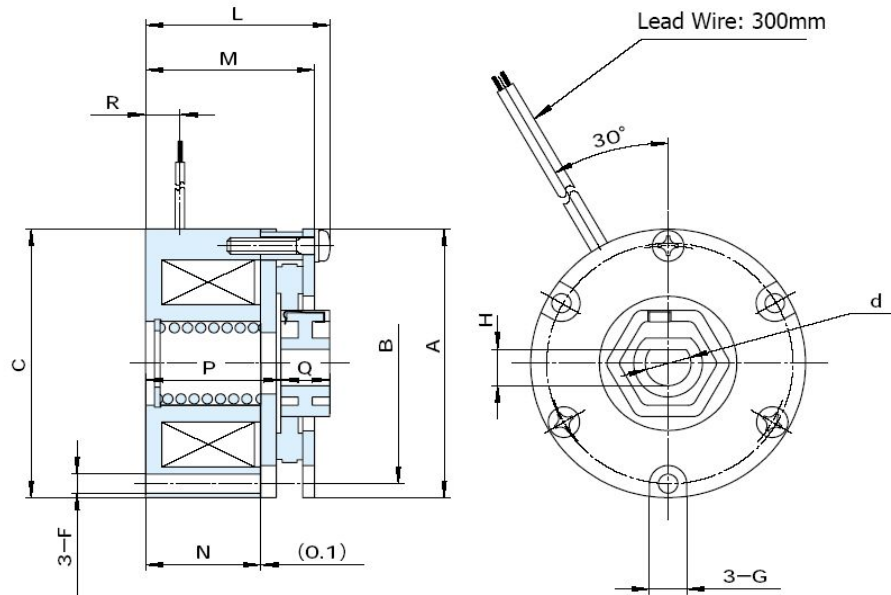

MCNB	Stopping	2GS	2KS	5GS	5KS	10GS	10KS
	Holding	2GR	2KR	5GR	5KR	10GR	10KR
Static Torque [in-lbs / N-m]		1.8 / 0.2		4.4 / 0.5		8.9 / 1	
Coil (20°C)	Voltage [DC-V]	24	90	24	90	24	90
	Current [A]	0.175	0.047	0.271	0.072	0.293	0.078
	Resistance [Ω]	137	1928	88.6	1246	82	1157
	Wattage [W]	4.2		6.5		7	
Armature	Pull-In Time <sup>1</sup> [ms]	12		17		24	
	Release Time <sup>1</sup> [ms]	6		6		6	
Moment of Inertia (J) [kg-cm <sup>2</sup> ]		0.0026		0.0094		0.0173	
Max Work Rate [W]	Dynamic	5		10		18	
	Holding	2.5		5		9	
Total Energy Until Life [J]	Dynamic	2.8 × 10 <sup>6</sup>		5.3 × 10 <sup>6</sup>		6.0 × 10 <sup>6</sup>	
	Holding	1.4 × 10 <sup>6</sup>		2.7 × 10 <sup>6</sup>		3.0 × 10 <sup>6</sup>	
Bore [mm]	dH9	8		8		10	
Dimensions [mm]	A	40		48		58	
	B	35		43		52	
	C+0/-0.1	40		48		58	
	F	3		3.4		3.4	
	G	6		6.5		7	
	H+0.1/-0	6.5		6.5		8	
	L	29		33		35	
	M	26		29.5		32	
	N	18		20		22.5	
	P+0.3/-0.1	21		23.6		26	
Q	8.5		8.5		8.5		
R	6		6		6		
Weight [lbs / kg]		0.37 / 0.17		0.57 / 0.26		0.93 / 0.42	

[ Note 1 : TNR15G471K varistor, 0.1mm gap ]

[ 1" = 25.4mm ]



**New Version**  
[ with hex hub ]

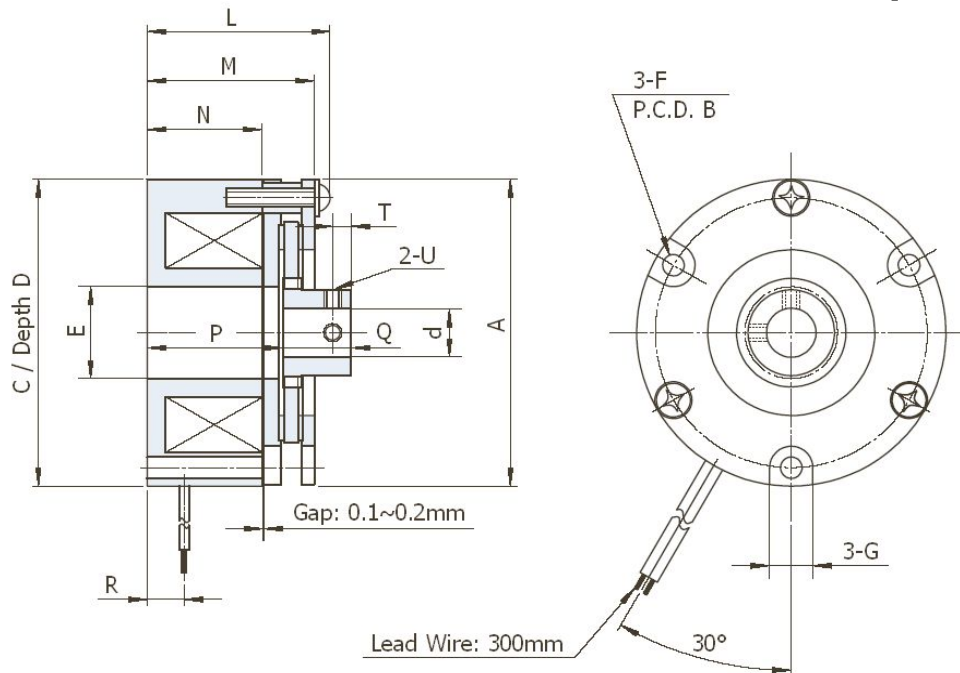

MCNB		2G	2H	5G	5H	10G	10H
Static Torque [in-lbs / N-m]		1.8 / 0.2		4.4 / 0.5		8.9 / 1	
Coil (20°C)	Voltage [DC-V]	24	45	24	45	24	45
	Resistance [Ω]	135	400	89	350	66	270
	Wattage [W]	5		7		9	
Armature	Pull-In Time [ms]	20		25		30	
	Release Time [ms]	5		5		10	
Moment of Inertia (J) [kg-cm <sup>2</sup> ]		0.01		0.033		0.085	
Max Work Rate [W]		5		10		18	
Total Energy Until Life [J]		2.8 x 10 <sup>6</sup>		5.3 x 10 <sup>6</sup>		6.0 x 10 <sup>6</sup>	
Dimensions [mm]	Bore [mm]	dH8	8	8	10	10	10
	A		40	50	63	63	63
	B		34	44	54	54	54
	Ch9		40	50	63	63	63
	D		3	3	3	3	3
	E		10	15	22	22	22
	F		3.5	3.5	4.5	4.5	4.5
	G		7	7	9	9	9
	L		30	30	31	31	31
	M		27	27	27	27	27
	N		20	18.7	17.8	17.8	17.8
	P		23	22	21	21	21
	Q		10	11	13	13	13
	R		6	6	6	6	6
	T		3	3	4	4	4
U		M3	M3	M4	M4	M4	
Weight [lbs / kg]		0.42 / 0.19		0.62 / 0.28		0.95 / 0.43	



**Old Version**  
[ with spline hub ]

[ 1" = 25.4mm ]

# MCNB: TYPICAL INSTALLATION

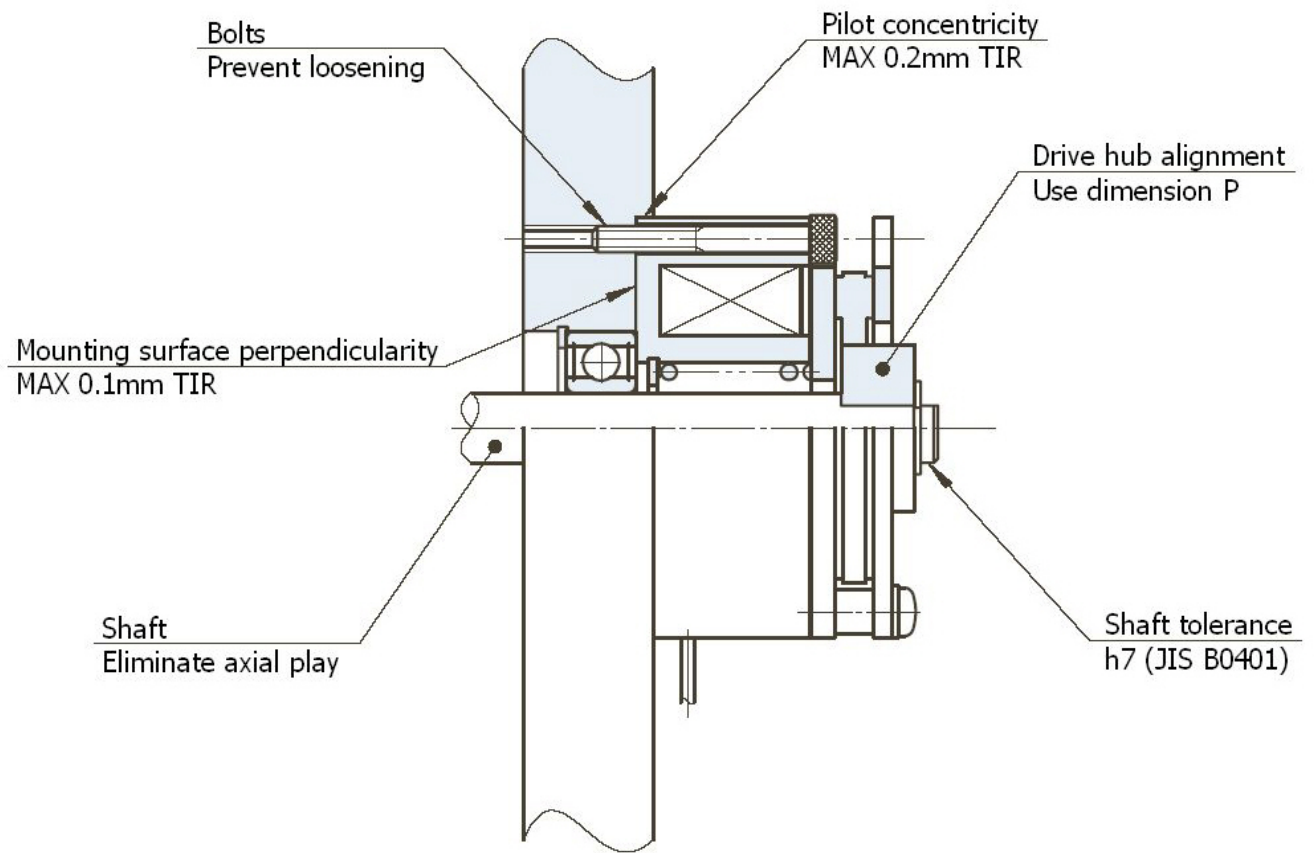



# MCLB

# Micro EM Spring-Applied Brake

Types: 5

[ EM: Electromagnet ]

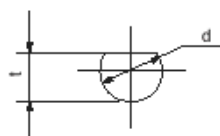
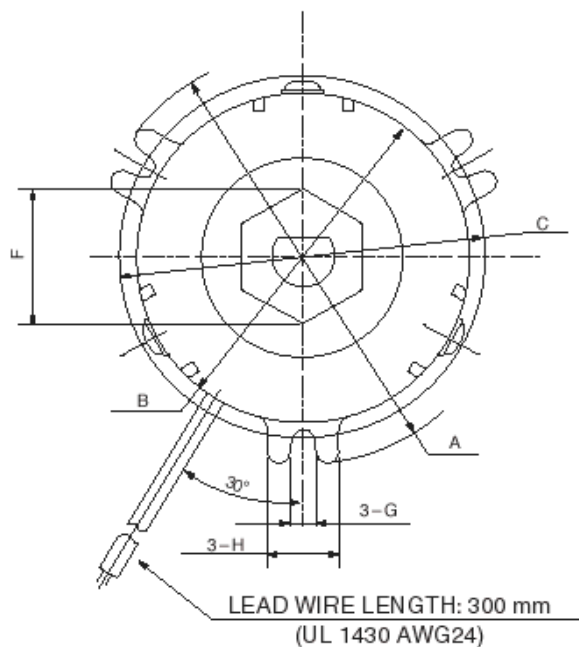
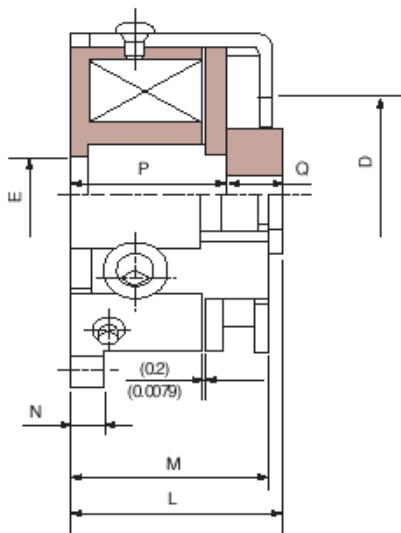

[Min order 100 pcs]

MCLB		5G	5H
Static Torque [in-lbs / N-m]		4.4 / 0.5	
Coil (20°C)	Voltage [DC-V]	24	45
	Resistance [ $\Omega$ ]	91	318
	Wattage [W]	6.4	
Armature	Pull-In Time [ms]	25	
	Release Time [ms]	20	
Total Energy Until Life [J]		$3.0 \times 10^5$	
Max Work Rate [W]		10	
Moment of Inertia (J) [kg-cm <sup>2</sup> ]		0.03	
Bore [mm]	dH9	8	
	t+0.1/-0	6.5	
Dimensions [mm]	A+0/-0.3	62	
	B	50	
	C±0.2	56	
	D	30	
	E	11	
	F	20.2	
	G	3.5	
	H	11	
	L	32	
	M	30	
	N	5	
	P+0.2/-0	23.5	
	Q	8.5	
Weight [lbs / kg]		0.6 / 0.3	

[ 1" = 25.4mm ]

# FNB

S E R I E S

## POWER OFF BRAKE

Torque Range: 9 ~ 71 in-lbs

Torque Range: 1.0 ~ 8.0 N-m

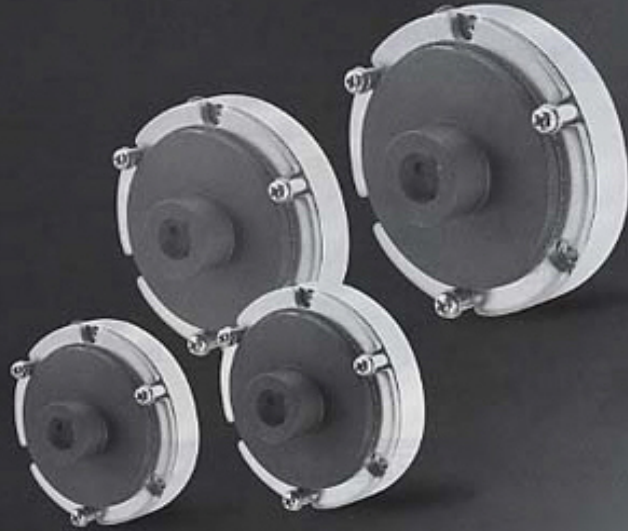

## FEATURES

### **BRAKE FOR HOLDING AND EMERGENCY STOPPING**

The friction disk and the pressure plate are one piece so when the power is applied there are no loose parts, so there is no chance of noise and/or contact. This also makes brake release time very quick.

### **FLEXIBLE HUB DESIGN, LOWEST COST OPTION**

The FNB series does not come with a hub (shown in black in the picture). The hub is customer supplied, but this provides the lowest cost option available.

### **FAST RESPONSE**

The brake engages via springs which are unaffected by minor temperature changes or voltage fluctuations.

### **SIMPLE DESIGN, EASY INSTALLATION**

The FNB has few moving parts and comes equipped with a spacer collar to set the air gap for the hub.

### **COMPACT DESIGN**

Like the SNB and RNB, the FNB can provide a solution when there is limited space available.



Model FNB

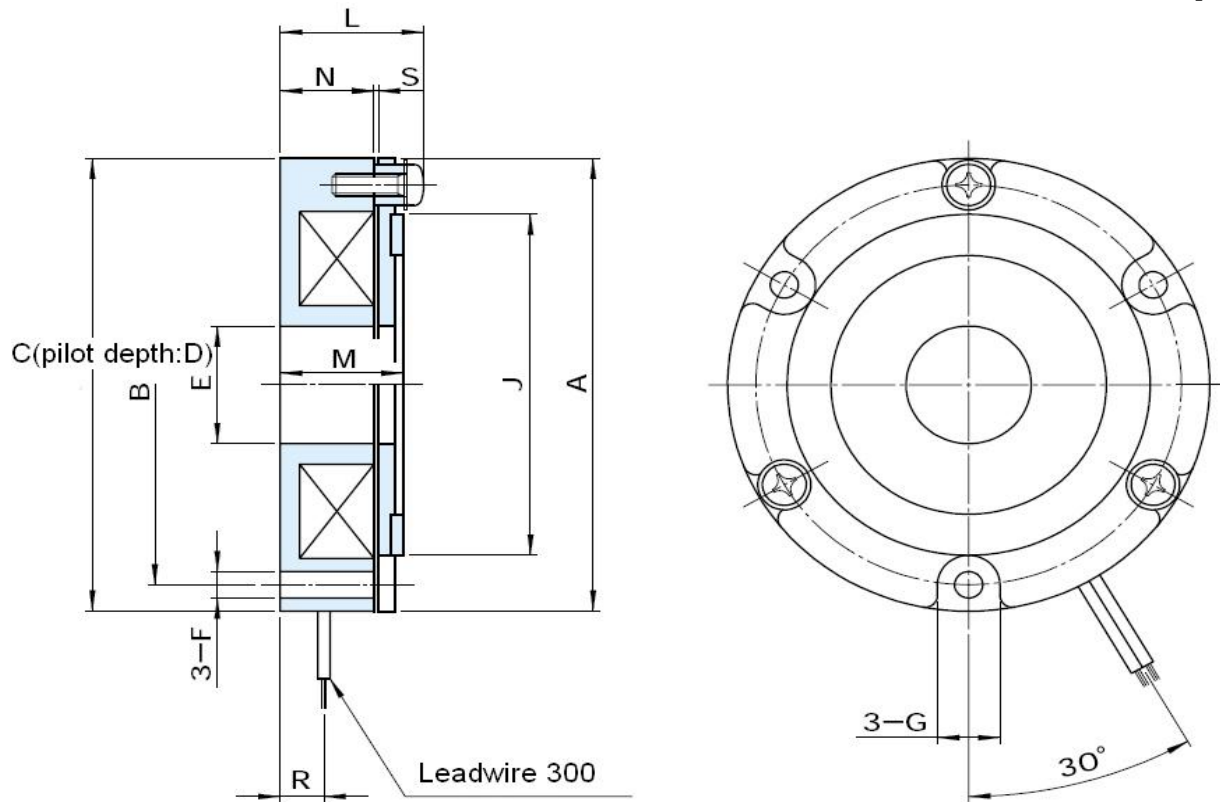

[ Special Order ]

FNB		0.1G	0.1K	0.2G	0.2K	0.4G	0.4K	0.8G	0.8K
Static Torque [in-lbs / N-m]		9 / 1		18 / 2		35 / 4		71 / 8	
Coil (20°C)	Voltage [DC-V]	24	90	24	90	24	90	24	90
	Current [A]	0.41	0.11	0.54	0.14	0.63	0.17	0.76	0.2
	Resistance [Ω]	59	815	45	630	38	540	32	445
	Wattage [W]	10		13		15		18	
Armature	Pull-In Time <sup>1</sup> [ms]	35		45		55		70	
	Release Time <sup>1</sup> [ms]	12		12		15		25	
Max Allowable Speed [rpm]		5000		4000		4000		3500	
Dimensions [mm]	A	77		85		97		117	
	B	68		74		85		108	
	Ch	77		85		97		117	
	D	3		4		4		4	
	E	20		20		25		40	
	F	4.5		5.5		5.5		5.5	
	G	10		11		11		11	
	J	58		62		72		93	
	L	23		24.5		26.5		30.5	
	M	19.7		21.2		22		25.5	
	N	15		16		17		19.5	
	R	7		7.5		8.5		8.5	
S	0.15~0.25		0.15~0.25		0.15~0.25		0.15~0.25		
Weight [lbs / kg]		1.1 / 0.5		1.4 / 0.6		2.0 / 0.9		3.1 / 1.4	

[ 1" = 25.4mm ]

# FNB: TYPICAL INSTALLATION

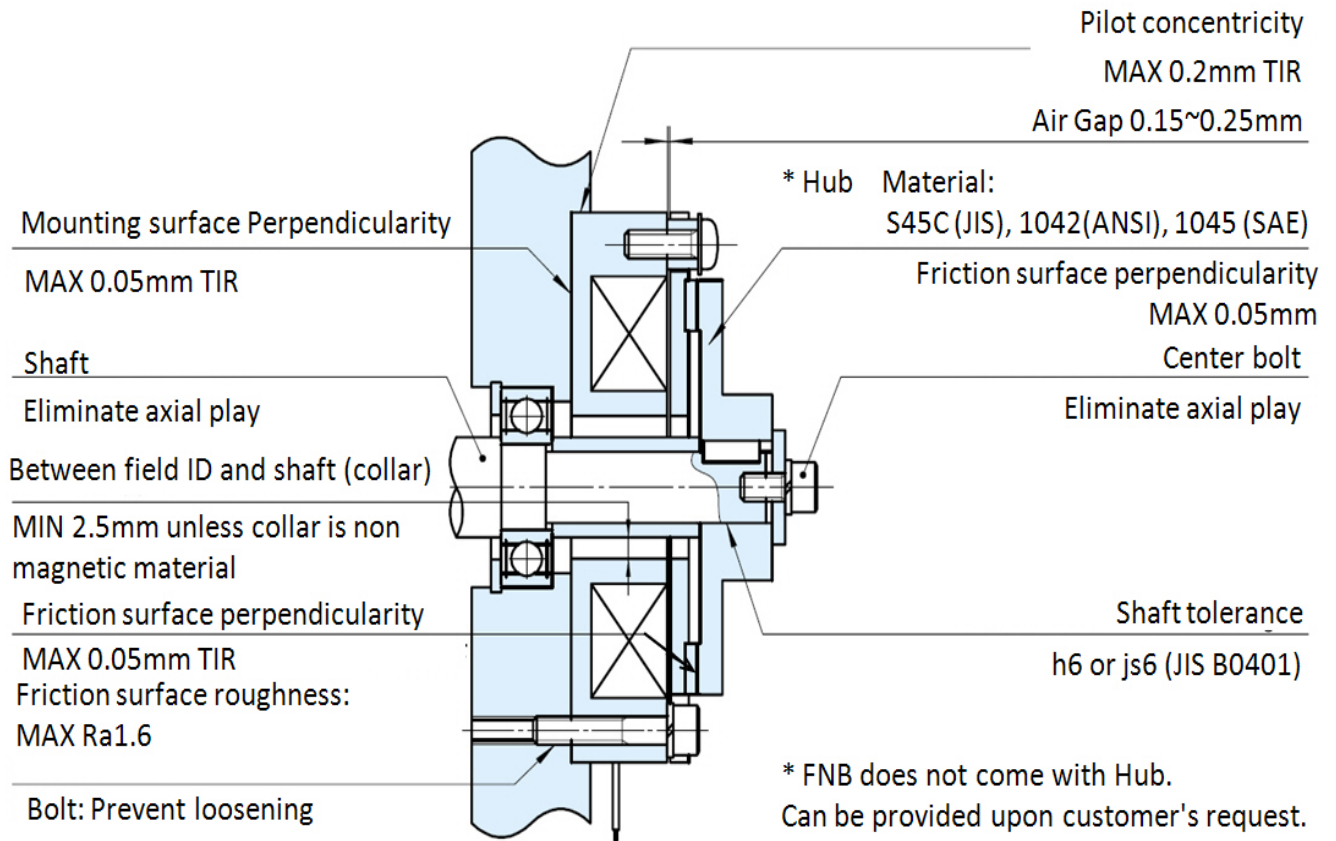

# SNB

S E R I E S

## ELECTROMAGNETIC SPRING-APPLIED BRAKE

Torque Range: 0.7 ~ 74 ft-lbs

Torque Range: 1 ~ 100 N-m



## FEATURES

### COMPACT DESIGN WITH HIGH TORQUE

The SNB series brakes are approximately one-half the width of MNB style.

### BASIC DESIGN ADVANTAGE

The SNB series is designed for stopping and holding.

### MANUAL RELEASE HOLES

Starting with SNB series 1.2 and RNB series 3 and higher all units have three tapped holes in which screws can be inserted for manually releasing the brake in case of emergency.

### FAST RESPONSE TIME

These brakes are spring-set type brakes, providing rapid torque buildup.

### LONGEVITY

The use of wear-resistant friction material provides extended operational life.

### OPERATING VOLTAGE OPTIONS

SNB units come in two standard voltages, 90VDC and 24VDC. Other non-standard voltages are available.



SNB

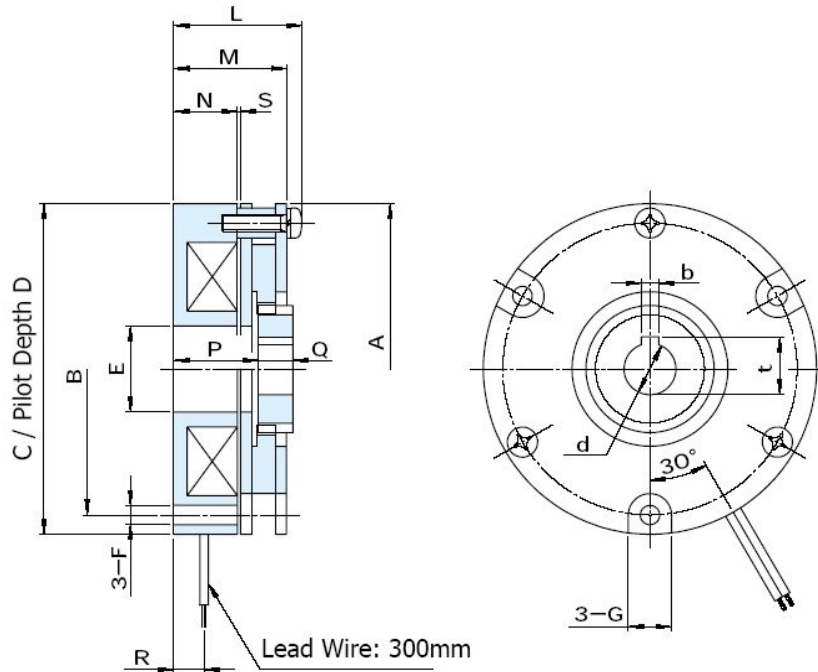

SNB		0.1G	0.1K	0.2G	0.2K	0.4G	0.4K	0.8G	0.8K
Static Torque [ft-lbs / N-m]		0.7 / 1		1.5 / 2		3 / 4		5.9 / 8	
Coil (20°C)	Voltage [DC-V]	24	90	24	90	24	90	24	90
	Current [A]	0.41	0.11	0.54	0.14	0.63	0.17	0.76	0.2
	Resistance [Ω]	59	815	45	630	38	540	32	445
	Wattage [W]	10		13		15		18	
Armature	Pull-In Time [ms]	25		30		40		55	
	Release Time [ms]	15		15		20		35	
Max Allowable Speed [rpm]		5000		4000		4000		3500	
Max Brake Power [W]		33		41		57		98	
Moment of Inertia (J) [kg-cm <sup>2</sup> ]		0.16		0.28		0.43		1.22	
Max Air Gap Until Adjustmnet [mm]		0.55		0.55		0.6		0.6	
Max Energy Until Life [J]		1.6 x 10 <sup>7</sup>		1.9 x 10 <sup>7</sup>		3.0 x 10 <sup>7</sup>		5.6 x 10 <sup>7</sup>	
Max Work Rate [W]		33		47		57		98	
Bore [mm]	dH7	12	12	12	12	14	14	19	19
Key Way [mm]	bE9	4	4	4	4	5	5	5	5
	t+0.15/-0	13.5	13.5	13.5	13.5	16	16	21	21
Dimensions [mm]	A	77	85	85	85	97	97	117	117
	B	68	74	74	74	85	85	108	108
	Ch9	77	85	85	85	97	97	117	117
	D	3	4	4	4	4	4	4	4
	E	20	20	20	20	25	25	40	40
	F	4.5	5.5	5.5	5.5	5.5	5.5	5.5	5.5
	G	10	11	11	11	11	11	11	11
	L	30	32	32	32	35	35	41	41
	M	26	28	28	28	30	30	35	35
	N	15	16	16	16	17	17	19.5	19.5
	P	19.5	21	21	21	22	22	25.5	25.5
	Q	8	8	8	8	8	8	10	10
	R	7	7.5	7.5	7.5	8.5	8.5	8.5	8.5
S		0.1~0.25	0.1~0.25	0.1~0.25	0.1~0.25	0.1~0.25	0.1~0.25	0.1~0.25	0.1~0.25
Weight [lbs / kg]		1.2 / 0.5		1.8 / 0.8		2.4 / 1.1		4.0 / 1.8	



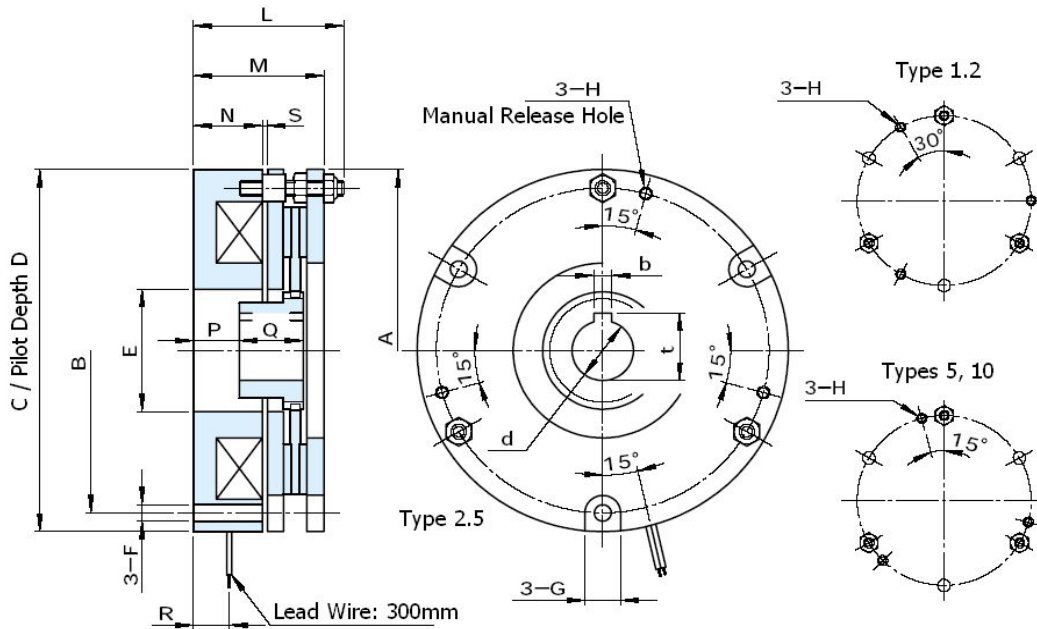

SNB		1.2G	1.2K	2.5G	2.5K	5G	5K	10G	10K
Static Torque [ft-lbs / N-m]		8.9 / 12		18 / 25		37 / 50		74 / 100	
Coil (20°C)	Voltage [DC-V]	24	90	24	90	24	90	24	90
	Current [A]	0.96	0.25	1.13	0.3	1.37	0.37	1.88	0.5
	Resistance [Ω]	25	358	21	300	17.5	245	12.8	180
	Wattage [W]	23		27		33		45	
Armature	Pull-In Time [ms]	70		90		135		200	
	Release Time [ms]	40		60		80		110	
Max Allowable Speed [rpm]		3500		3000		3000		2500	
Max Brake Power [W]		98		114		155		212	
Moment of Inertia (J) [kg-cm <sup>2</sup> ]		3		6		14.5		25	
Max Air Gap Until Adjustmnet [mm]		0.65		0.65		0.7		0.8	
Max Energy Until Adjustment [J]		5.5 x 10 <sup>7</sup>		7.7 x 10 <sup>7</sup>		9.1 x 10 <sup>7</sup>		1.6 x 10 <sup>8</sup>	
Max Energy Until Life [J]		2.0 x 10 <sup>8</sup>		3.4 x 10 <sup>8</sup>		4.8 x 10 <sup>8</sup>		7.9 x 10 <sup>8</sup>	
Max Work Rate [W]		98		114		155		212	
Bore [mm]	dH7	19		24		28		32	
Key Way [mm]	bE9	5		7		7		10	
	t+0.15/-0	21		27		31		35.5	
Dimensions [mm]	A	125		145		165		187	
	B	112		130		150		170	
	Ch9	125		145		165		187	
	D	4		5		5		6	
	E	49		49		62		62	
	F	6.6		6.6		9		9	
	G	14		14		18		18	
	H	M5		M5		M6		M6	
	L	54		59		71		83	
	M	46		51		61		72	
	N	26		27		32		37	
	P	16		18		22		21	
	Q	25		25		30		40	
	R	11		14		17		21	
S	0.15~0.3		0.15~0.3		0.15~0.3		0.2~0.35		
Weight [lbs / kg]		7.7 / 3.5		11 / 5		17 / 8		28 / 13	

## SNB: TORQUE CHARACTERISTIC

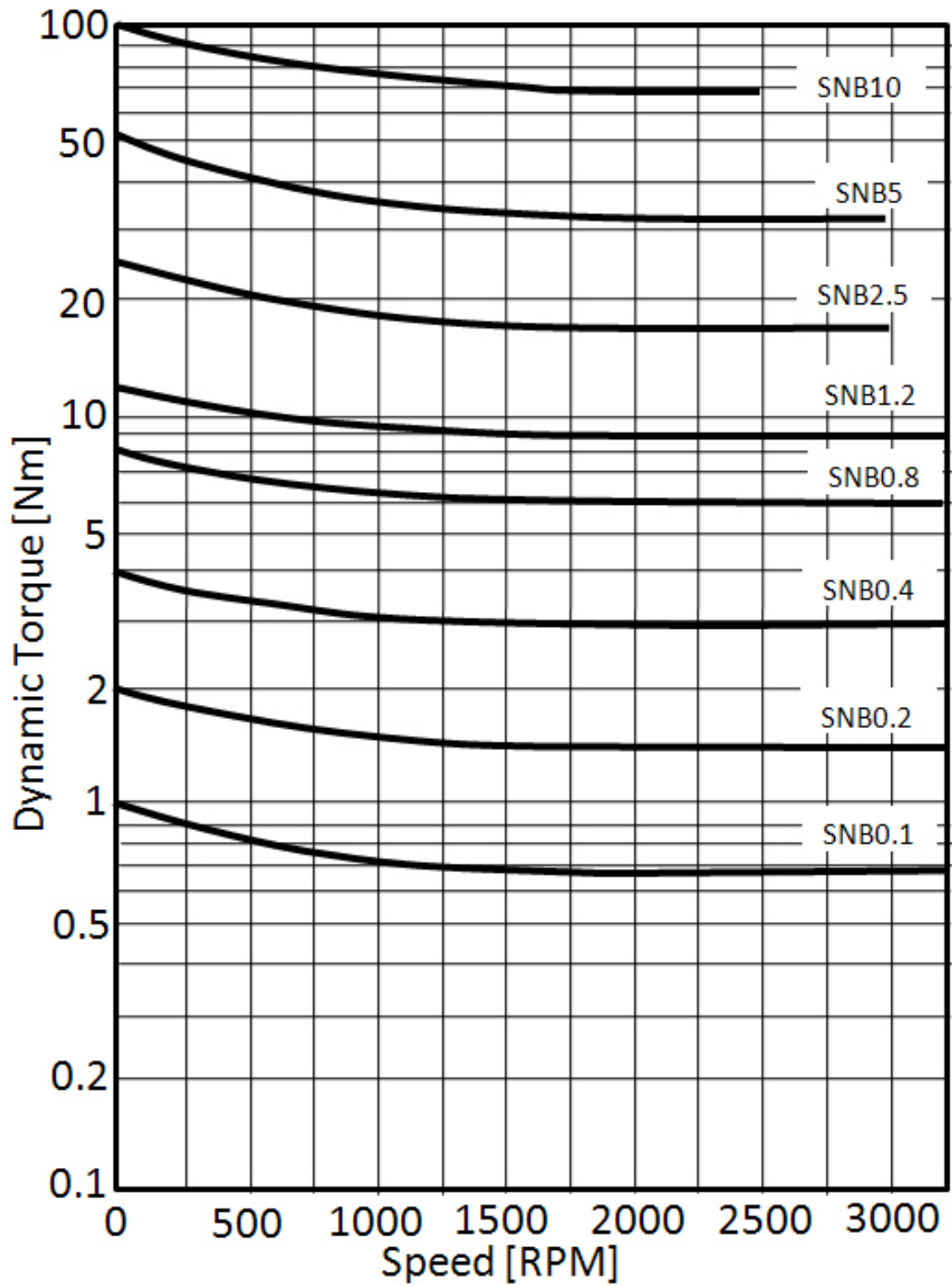

# SNB & RNB: TYPICAL INSTALLATION

SNB Brake

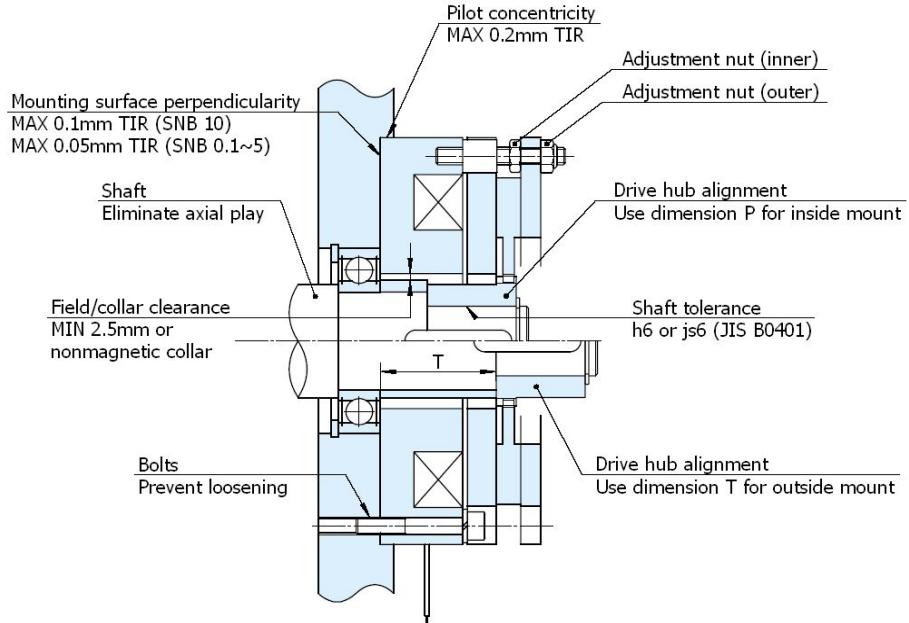

RNB Brake

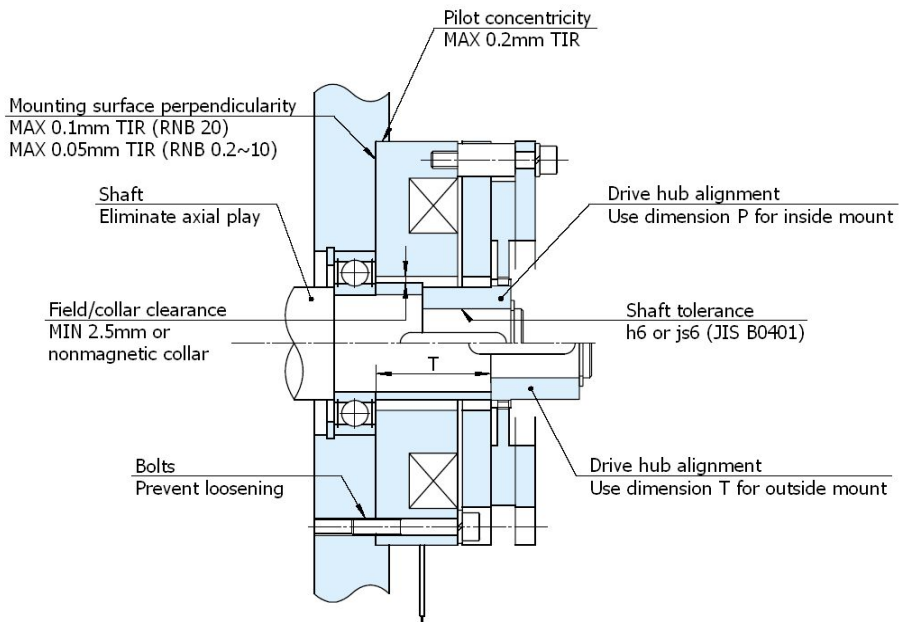

	SNB1.2	SNB2.5	SNB5	SNB10	RNB0.2	RNB0.4	RNB0.8	RNB1.6	RNB3	RNB5	RNB10	RNB20
T [mm]	33	35	43	52	20	21	22	25	33	35	43	52

# RNB

S E R I E S

**ELECTROMAGNETIC  
SPRING-APPLIED BRAKE**  
Torque Range: 1.5 ~ 148 ft-lbs  
Torque Range: 2 ~ 200 N-m



## FEATURES

### COMPACT DESIGN WITH HIGH TORQUE

The RNB series brakes are approximately one-half the width of MNB style.

### BASIC DESIGN ADVANTAGE

The RNB series brake is designed for holding and emergency braking.

### MANUAL RELEASE HOLES

Starting with SNB series 1.2 and RNB series 3 and higher all units have three tapped holes in which screws can be inserted for manually releasing the brake in case of emergency.

### FAST RESPONSE TIME

These brakes are spring-set type brakes, providing rapid torque buildup.

### OPERATING VOLTAGE OPTIONS

RNB units come in two standard voltages, 90VDC and 24VDC. Other non-standard voltages are available.

### OPTIONAL ZERO BACKLASH DESIGN (RNB-Z)

Thin disks in the RNB-Z produce low inertia. A zero backlash design also eliminates any noise due to rattling.



RNB

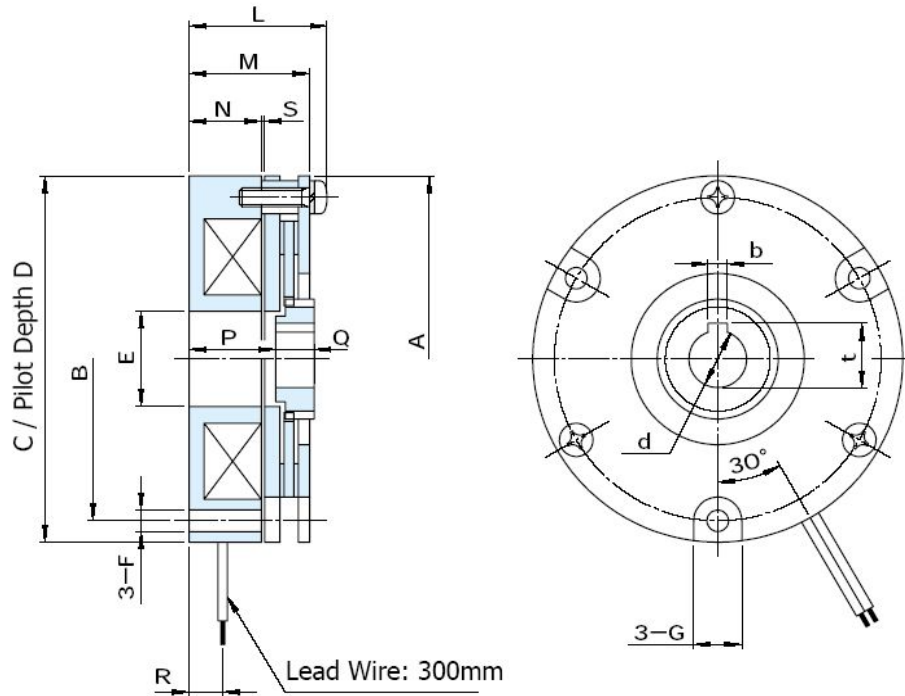

RNB <sup>1</sup>		0.2G	0.2K	0.4G	0.4K	0.8G	0.8K	1.6G	1.6K
Static Torque [ft-lbs / N-m]		1.5 / 2		3 / 4		5.9 / 8		12 / 16	
Coil (20°C)	Voltage [DC-V]	24	90	24	90	24	90	24	90
	Current [A]	0.41	0.11	0.54	0.14	0.63	0.17	0.76	0.2
	Resistance [Ω]	59	815	45	630	38	540	32	445
	Wattage [W]	10		13		15		18	
Armature	Pull-In Time [ms]	35		45		55		70	
	Release Time [ms]	12		12		15		25	
Max Allowable Speed [rpm]		5000		4000		4000		3500	
Moment of Inertia (J) [kg-cm <sup>2</sup> ]		0.185		0.325		0.675		2.85	
Bore [mm]	dH7	12		12		14		19	
Key Way [mm]	bE9	4		4		5		5	
	t+0.15/-0	13.5		13.5		16		21	
Dimensions [mm]	A	77		85		97		117	
	B	68		74		85		108	
	Ch9	77		85		97		117	
	D	3		4		4		4	
	E	20		20		25		40	
	F	4.5		5.5		5.5		5.5	
	G	10		11		11		11	
	L	30		32		35		41	
	M	25.5		27.5		29.5		34.5	
	N	15		16		17		19.5	
	P	18		16		14		15	
	Q	8		12		16		20	
	R	7		7.5		8.5		8.5	
S	0.15~0.3		0.15~0.3		0.15~0.3		0.15~0.3		
Weight [lbs / kg]		1.3 / 0.6		1.9 / 0.9		2.6 / 1.2		4.2 / 1.9	

[ Note 1 : For holding and emergency-stop applications only ]

[ 1 inch = 25.4 mm ]

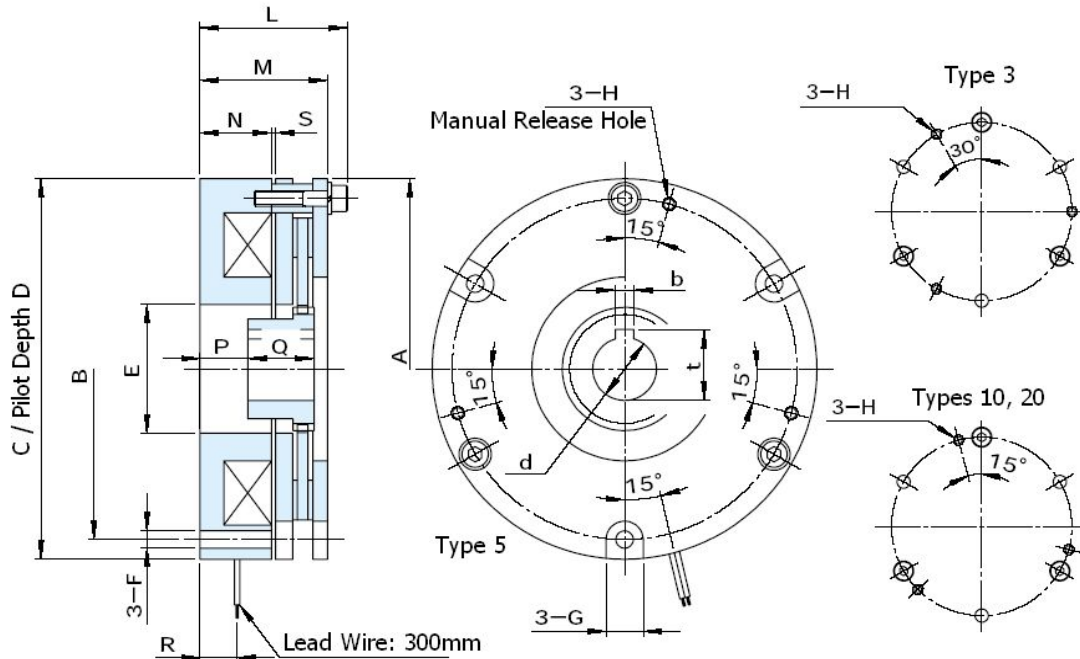

RNB <sup>1</sup>		3G	3K	5G	5K	10G	10K	20G	20K
Static Torque [ft-lbs / N-m]		22 / 30		37 / 50		74 / 100		148 / 200	
Coil (20°C)	Voltage [DC-V]	24	90	24	90	24	90	24	90
	Current [A]	0.96	0.25	1.13	0.3	1.37	0.37	1.88	0.5
	Resistance [Ω]	25	358	21	300	17.5	245	12.8	180
	Wattage [W]	23		27		33		45	
Armature	Pull-In Time [ms]	100		120		180		250	
	Release Time [ms]	35		50		65		90	
Max Allowable Speed [rpm]		3500		3000		3000		2500	
Moment of Inertia (J) [kg-cm <sup>2</sup> ]		3		5.75		13		21	
Bore [mm]	dH7	19		24		28		32	
Key Way [mm]	bE9	5		7		7		10	
	t+0.15/-0	21		27		31		35.5	
Dimensions [mm]	A	125		145		165		187	
	B	112		130		150		170	
	Ch9	125		145		165		187	
	D	4		5		5		6	
	E	49		49		62		62	
	F	6.6		6.6		9		9	
	G	14		14		18		18	
	H	M5		M5		M6		M6	
	L	53.5		56.5		71		81	
	M	46		49		61		71	
	N	26		27		32		37	
	P	16		18		22		21	
	Q	25		25		30		40	
R	11		14		17		21		
S	0.15~0.3		0.15~0.3		0.15~0.3		0.2~0.35		
Weight [lbs / kg]		7.9 / 3.6		11 / 5		17 / 8		27 / 12	

[ Note 1 : For holding and emergency-stop applications only ]

[ 1 inch = 25.4 mm ]



# RNB-Z

## EM Spring-Applied Brake

Types: 0.2, 0.4, 0.8, 1.6

[ EM: Electromagnet ]

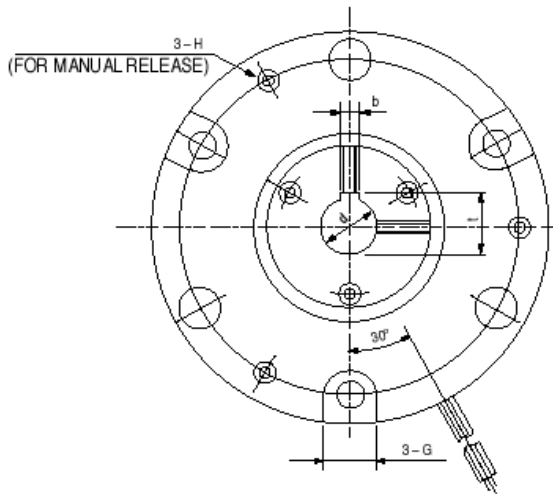
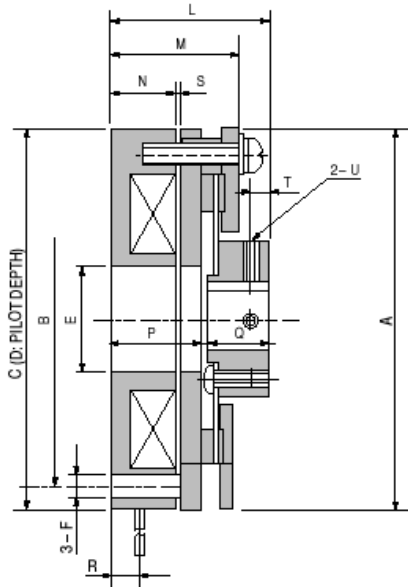

RNB <sup>1</sup>		0.2ZG	0.2ZK	0.4ZG	0.4ZK	0.8ZG	0.8ZK	1.6ZG	1.6ZK
Static Torque [ft-lbs / N-m]		1.5 / 2		3 / 4		5.9 / 8		12 / 16	
Coil (20°C)	Voltage [DC-V]	24	90	24	90	24	90	24	90
	Current [A]	0.41	0.11	0.54	0.14	0.63	0.17	0.76	0.2
	Resistance [Ω]	59	815	45	630	38	540	32	445
	Wattage [W]	10		13		15		18	
Armature	Pull-In Time [ms]	35		45		55		70	
	Release Time [ms]	12		12		15		25	
Max Allowable Speed [rpm]		5000		4000		4000		3500	
Moment of Inertia (J) [kg-cm <sup>2</sup> ]		0.16		0.23		0.45		0.7	
Bore [mm]	dH7	12		12		14		15	
Key Way [mm]	bE9	4		4		5		5	
	t+0.15/-0	13.5		13.5		16		17	
Dimensions [mm]	A	77		85		97		117	
	B	68		74		85		108	
	Ch9	77		85		97		117	
	D	3		4		4		4	
	E	20		20		25		40	
	F	4.5		5.5		5.5		5.5	
	G	10		11		11		11	
	H	-		-		M4		M5	
	L	33		39		38.3		45.3	
	M	26		28		30		31.5	
	N	15		16		17		19.5	
	P	21		22		23.3		25.3	
	Q	12		17		15		20	
	R	7		7.5		8.5		8.5	
S	0.15~0.25		0.2~0.3		0.2~0.35		0.2~0.35		
T	4		4.5		4.5		5		
U	2xM4		2xM4		2xM5		2xM5		
Weight [lbs / kg]		1.3 / 0.6		1.9 / 0.9		2.6 / 1.2		4.2 / 1.9	

[ Note 1 : For holding and emergency-stop applications only ]

[ 1 inch = 25.4 mm ]

# RNB-Z: TYPICAL INSTALLATION

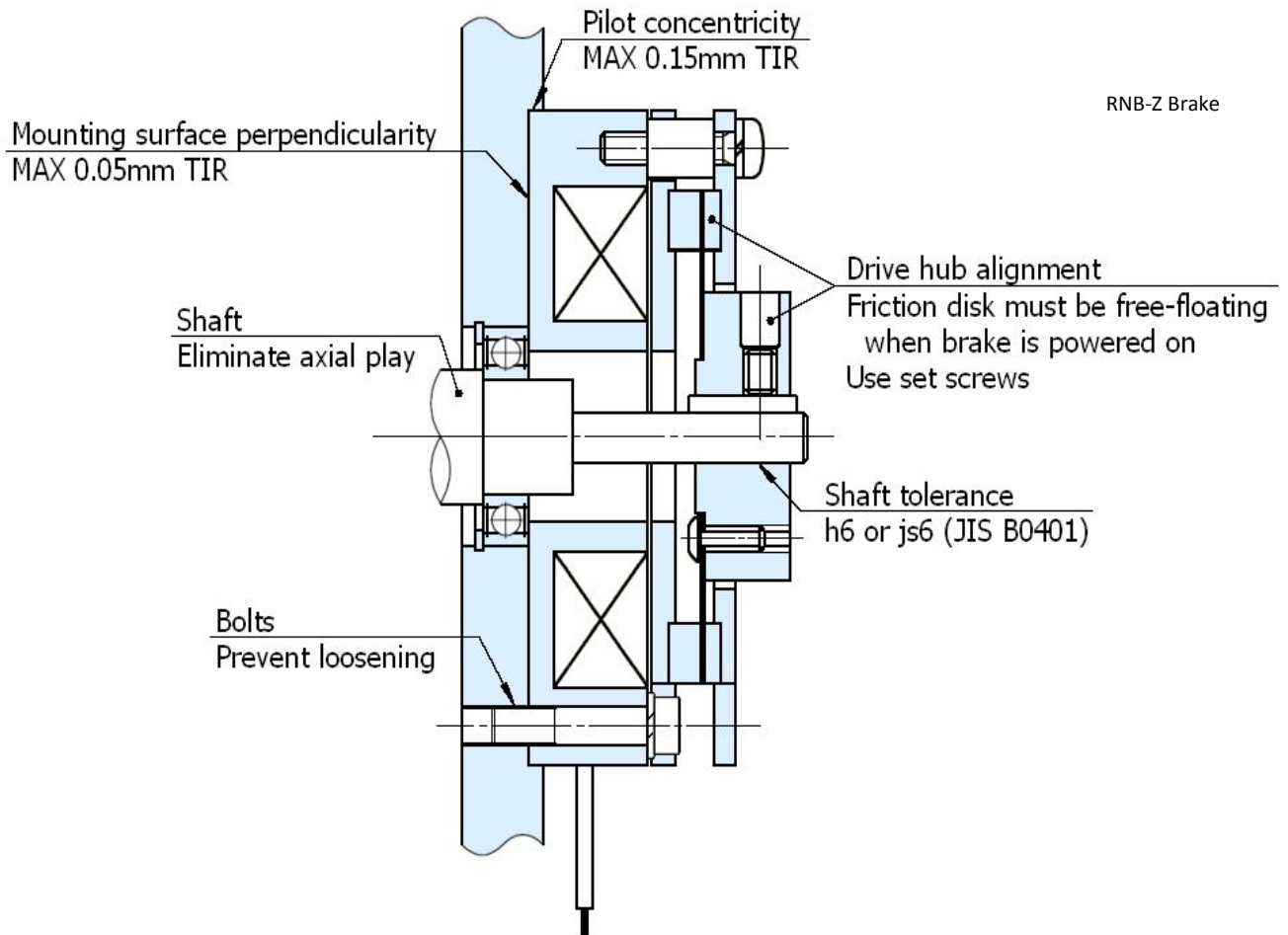

# MNB

S E R I E S

## ELECTROMAGNETIC SPRING-APPLIED BRAKE

Torque Range: 1.5 ~ 590 ft-lbs

Torque Range: 2 ~ 800 N-m

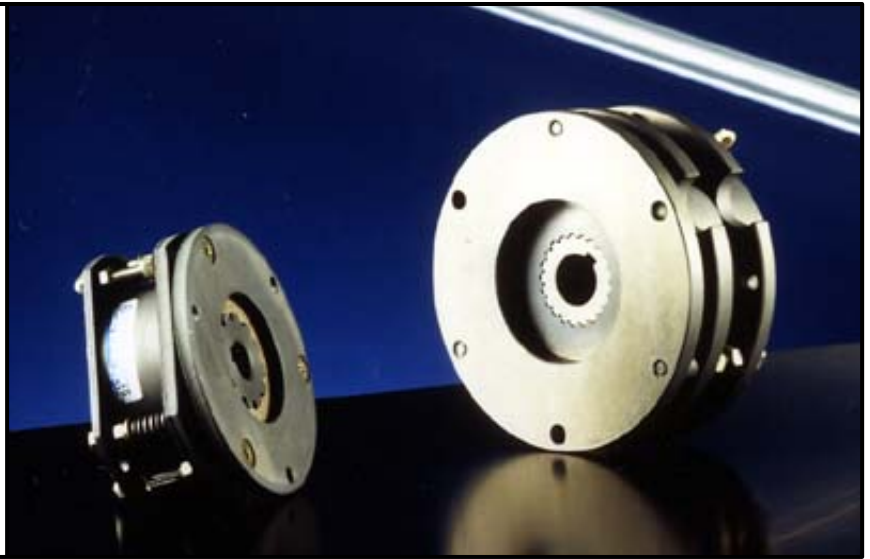

## FEATURES

### FAST RESPONSE TIME

The MNB series spring actuated brakes generate rapid torque buildup that gives rapid response.

### CAN HANDLE REPEATED STOPS

The MNB series is designed to not only hold a load, but also stop it.

### INSTALLATION ON SHORT SHAFTS

Short shaft designs can be accommodated because the mounting surface is on the inner drive side.

### OPERATING VOLTAGE OPTIONS

RNB units come in two standard voltages, 90VDC and 24VDC. Other non-standard voltages are available.

### EASILY ADJUSTABLE TORQUE

The torque can be adjusted over a wide range of settings via an adjusting bolt. This feature allows for controllable braking time.

### MANUAL RELEASE AVAILABLE

Holes are provided so a bolt can be inserted to provide for a manual release. Other special designs are possible.

### WIDE VARIETY OF CONTROLS AVAILABLE

Ogura has a wide selection of readily available controls to help control brakes for various applications.



MNB 0.2 ~ 0.8



MNB 1.2 ~ 80

# MNB

## EM Spring-Applied Brake

Types: 0.2, 0.4, 0.8

[ EM: Electromagnet ]

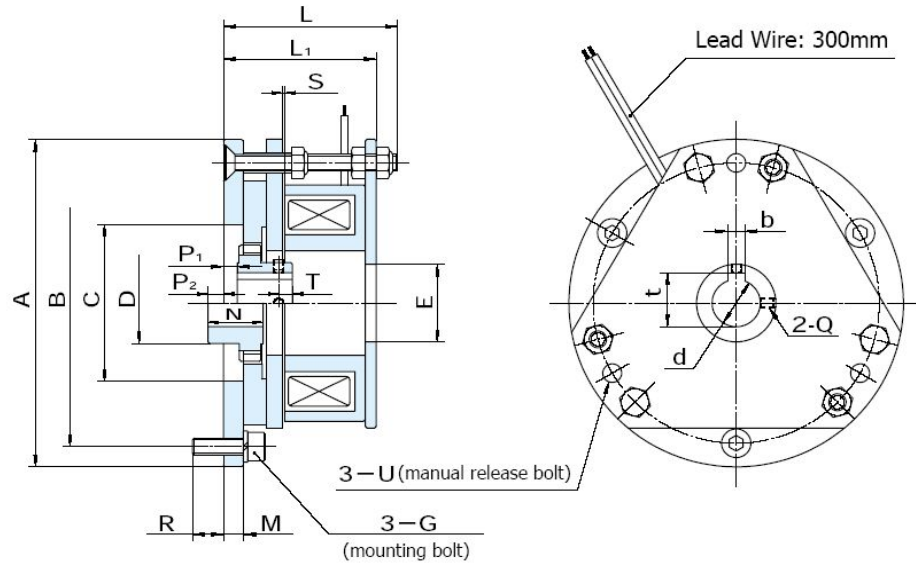

MNB		0.2G	0.2K	0.4G	0.4K	0.8G	0.8K
Static Torque [ft-lbs / N-m]		1.5 / 2		3 / 4		5.9 / 8	
Coil (20°C)	Voltage [DC-V]	24	90	24	90	24	90
	Current [A]	0.56	0.15	0.65	0.17	0.8	0.22
	Resistance [Ω]	43	600	37	520	30	410
	Wattage [W]	13.5	13.5	15.5	15.5	19	20
Armature	Pull-In Time [ms]	35	35	40	40	60	25 <sup>1</sup>
	Release Time [ms]	30	30	30	30	30	30 <sup>1</sup>
Max Allowable Speed [rpm]		4000		4000		3500	
Moment of Inertia (J) [kg-cm <sup>2</sup> ]		0.3		0.4		1.3	
Max Air Gap Until Adjustment [mm]		0.6		0.6		0.6	
Max Energy Until Adjustment [J]		1.7 x 10 <sup>7</sup>		2.7 x 10 <sup>7</sup>		4.0 x 10 <sup>7</sup>	
Max Energy Until Life [J]		4.0 x 10 <sup>7</sup>		6.0 x 10 <sup>7</sup>		9.0 x 10 <sup>7</sup>	
Max Work Rate [W]		41		57		98	
Bore [mm]	dh7	12		14		19	
Key Way [mm]	be9	4		5		5	
	t+0.15/-0	13.5		16		21	
Dimensions [mm]	A	85		97		120	
	B	74		85		108	
	C	44		46.5		68	
	D	24		24		32	
	E	20		23		40	
	G	M5		M5		M5	
	L	50.5		50.5		55.5	
	L1	43.5		44.3		49.1	
	M	4.7		5.7		5.7	
	N	16		16		25	
	P1	2.8		4		4	
	P2	5.7		4.5		11	
	Q	M3		M3		M4	
	R	7.8		8.8		8.8	
	S	0.1~0.35		0.1~0.35		0.1~0.35	
T	4		4		7		
U	M4-35		M5-35		M5-40		
Weight [lbs / kg]		1.8 / 0.8		2.2 / 1.0		3.3 / 1.5	

[ Included parts & accessories : bolts, washers, surge protector ]

[ 1" = 25.4mm ]

[ Note 1 : OFS 220 power supply ]

# MNB

## EM Spring-Applied Brake

Types: 1.2, 2.5, 5, 10, 20, 40, 80

[ EM: Electromagnet ]

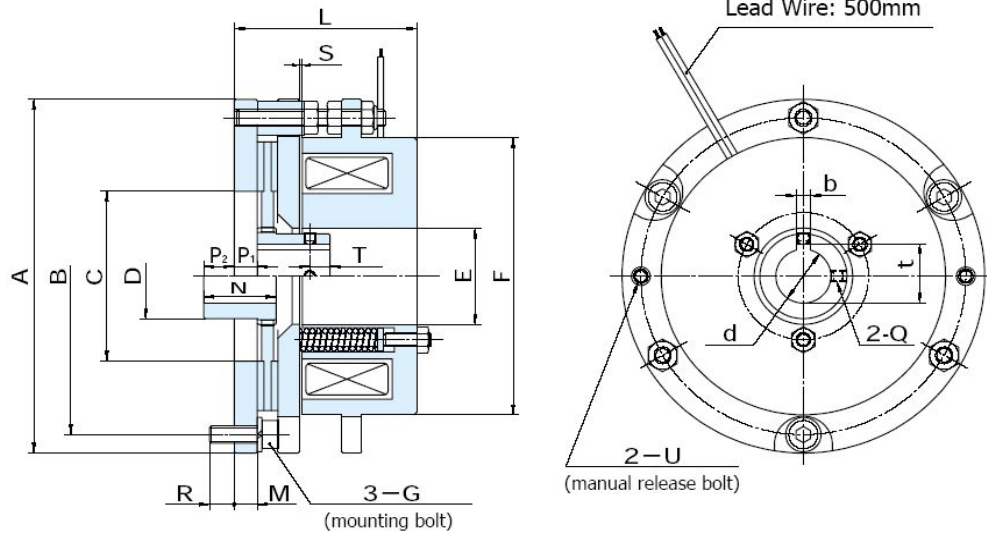

MNB		1.2G	1.2K	2.5G	2.5K	5G	5K	10G	10K	20J	20K	40J	40K	80J	80K
Static Torque [ft-lbs / N-m]		8.9 / 12		18 / 25		37 / 50		74 / 100		148 / 200		295 / 400		590 / 800	
Coil (20°C)	Voltage [DC-V]	24	90	24	90	24	90	24	90	72	90	72	90	72	90
	Current [A]	1	0.26	1.6	0.39	1.74	0.47	2.2	0.58	0.58	0.97	1.1	1.3	1.4	1.8
	Resistance [Ω]	24	350	15	230	14	190	11	150	150	74	82	55	62	40
	Wattage [W]	24	23	39	35	42	42	53	53	53	70	98	94	130	130
Armature	Pull-In Time [ms]	80	40 <sup>1</sup>	100	45 <sup>1</sup>	120	60 <sup>1</sup>	180	90 <sup>1</sup>	120 <sup>1</sup>	90 <sup>2</sup>	160	120 <sup>2</sup>	200	160 <sup>2</sup>
	Release Time [ms]	70	70 <sup>1</sup>	100	100 <sup>1</sup>	120	120 <sup>1</sup>	160	160 <sup>1</sup>	180 <sup>1</sup>	100 <sup>2</sup>	220	140 <sup>2</sup>	230	150 <sup>2</sup>
Max Allowable Speed [rpm]		3500		3000		3000		2500		2500		2000		2000	
Moment of Inertia (J) [kg-cm <sup>2</sup> ]		3		6		14.5		25		60		170		503	
Max Air Gap Until Adjustment [mm]		0.8		0.8		0.8		0.8		1		1.2		1.2	
Max Energy Until Adjustment [J]		7.2 x 10 <sup>7</sup>		1.0 x 10 <sup>8</sup>		1.4 x 10 <sup>8</sup>		1.6 x 10 <sup>8</sup>		3.0 x 10 <sup>8</sup>		5.6 x 10 <sup>8</sup>		7.0 x 10 <sup>8</sup>	
Max Energy Until Life [J]		2.0 x 10 <sup>8</sup>		3.4 x 10 <sup>8</sup>		4.8 x 10 <sup>8</sup>		7.9 x 10 <sup>8</sup>		1.2 x 10 <sup>9</sup>		2.2 x 10 <sup>9</sup>		3.2 x 10 <sup>9</sup>	
Max Work Rate [W]		123		147		245		327		490		590		700	
Bore [mm]	dH7	19	24	28	32	42	55	65							
Key Way [mm]	bE9	5	7	7	10	12	16	18							
	t+0.15/-0	21	27	31	35.5	45.5	60	71							
Dimensions [mm]	Ah9	125	145	165	190	230	275	340							
	B	112	130	150	170	210	250	305							
	CH9	60	75	85	95	125	150	180							
	D	30	38	45	52	65	80	95							
	E	34	44	54	60	70	90	105							
	F	98	116	134	152	186	220	270							
	G	M6	M6	M6	M8	M8	M12	M16							
	L	63	72	78	88	98	125	145							
	L <sup>3</sup>	63	72	78	88	98	143	167							
	M	8	9	10	11	12	15	18							
	N	25	30	35	40	50	60	70							
	P <sub>1</sub>	8	9	10	11	12	15	18							
	P <sub>2</sub>	10.5	13	16	18	27	31	33							
	Q	M4	M5	M6	M6	M8	M8	M8							
	R	8.5	9.5	8.5	12	11	17	23							
	S	0.1~0.35	0.1~0.35	0.1~0.35	0.2~0.45	0.2~0.45	0.2~0.45	0.3~0.55							
T	7	10	10	15	15	28	30								
U	M5-28	M6-30	M6-35	M8-40	M10-45	M12-85	M12-95								
Weight [lbs / kg]		7.3 / 3.3		11 / 5		16 / 7		24 / 11		41 / 19		77 / 35		137 / 62	

[ Note 1 : OFS 220 power supply ]

[ 1 inch = 25.4 mm ]

[ Note 2 : OHP 18H power supply ]

[ Note 3 : Total height including gap adjustment bolt ] 103

# MNB: TYPICAL INSTALLATION

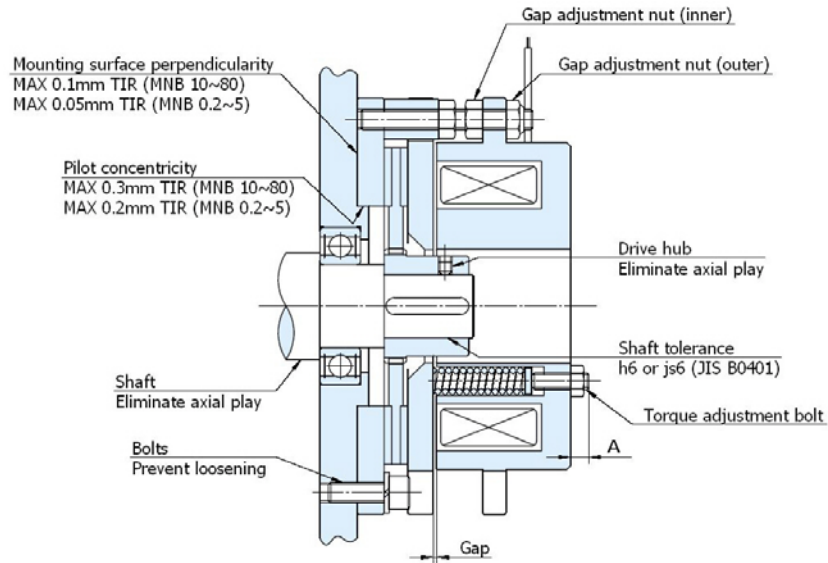

**MNB 1.2~80**

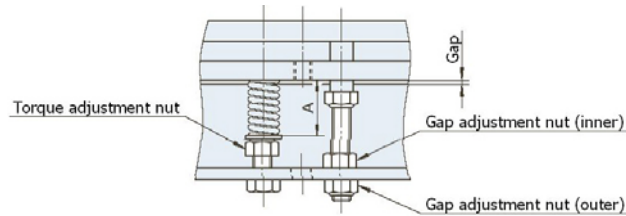

**MNB 0.2~0.8**

MNB	0.2	0.4	0.8	1.2	2.5	5	10	20	40	80
Normal Air Gap [mm]	0.1~0.35						0.2~0.45		0.3~0.55	
Max Air Gap [mm]	0.6			0.8			1	1.2		
Dimension A	<b>Torque [ft-lbs / Nm]</b>									
15.5	1.5 / 2	3 / 4								
16	1.2 / 1.6	2.4 / 3.2								
16.5	0.9 / 1.2	1.8 / 2.4								
20.5			5.9 / 8							
20.9			4.7 / 6.4							
21.3			3.5 / 4.8							
5				8.9 / 12						
6				7.0 / 9.5	18 / 25	37 / 50	74 / 100			
7										
8					15 / 20	30 / 40	59 / 80	148 / 200		
10					11 / 15	22 / 30	44 / 60	118 / 160		
12								89 / 120		
14									295 / 400	590 / 800
16									258 / 350	
17										516 / 700
18									221 / 300	
20										443 / 600



# MNB: TORQUE CHARACTERISTIC

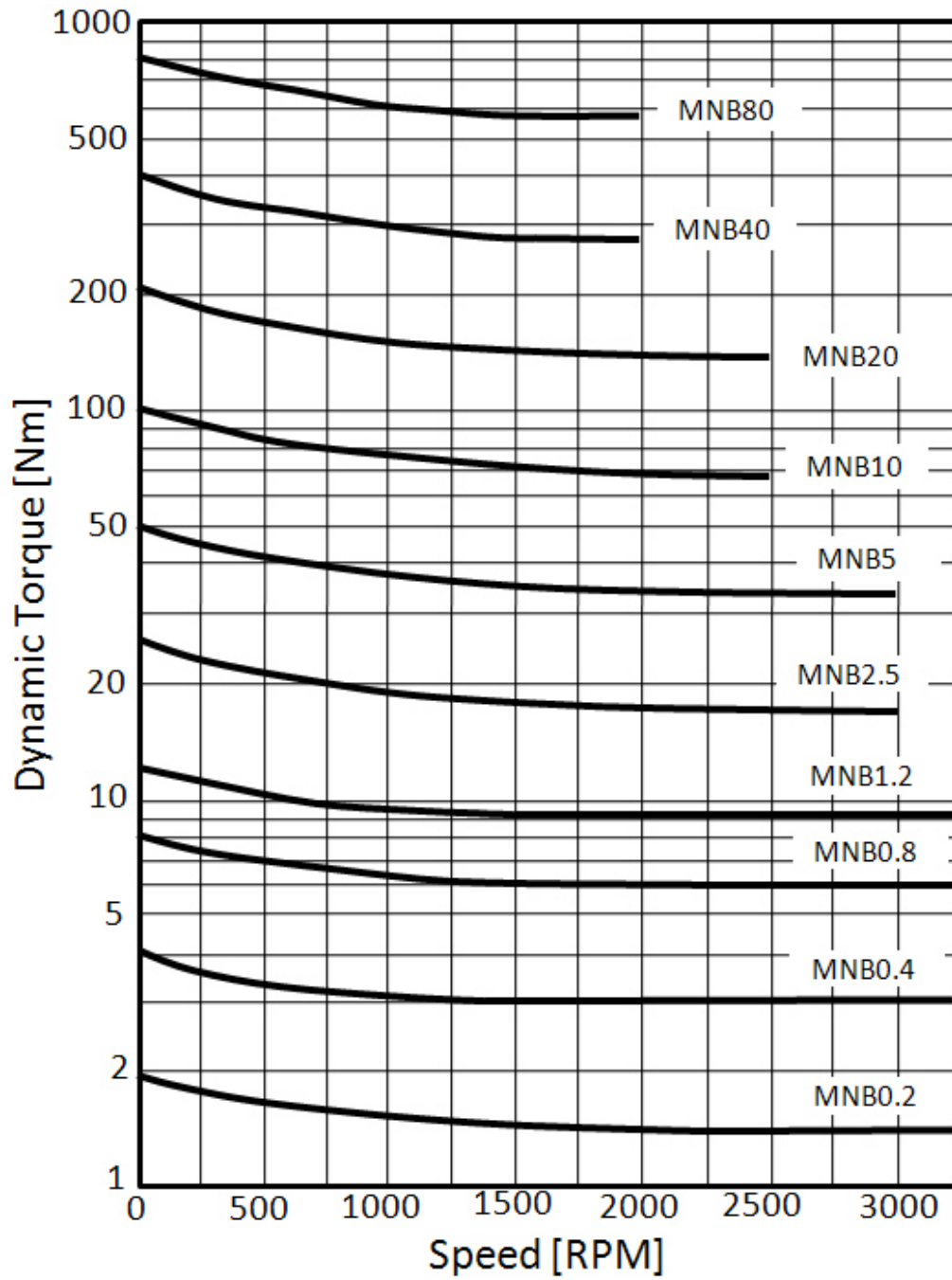

# PMB

S E R I E S

## POWER-OFF ELECTROMAGNETIC PERMANENT-MAGNET BRAKE

Torque Range: 3.5 ~ 266 in-lbs

Torque Range: 0.4 ~ 30.1 N-m

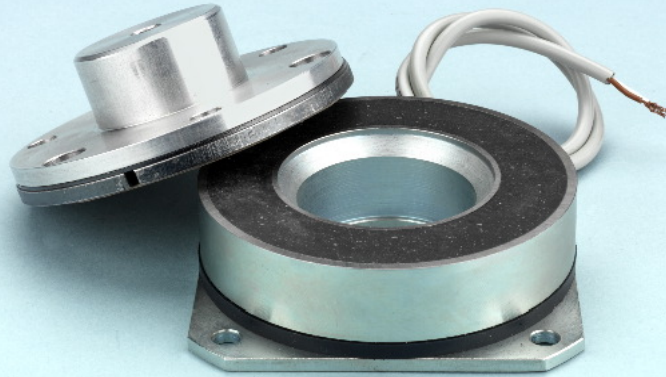

## FEATURES

### HIGH TORQUE COMPACT DESIGN

Because permanent magnets are used versus springs, the overall size of the brakes is smaller for a given torque size. Because the brakes are smaller, their weight is also less, which can be an advantage in some applications.

### CONTROLLED STOP

Since torque is directly controlled by flux, a brake can be tuned to provide a softer stop in an application versus having full torque applied.

### EASILY CUSTOMIZED FOR YOUR APPLICATION

Both the mounting flange and the output hub and armature assembly can be easily modified to fit your existing application.

### NOTE

Brakes require a variable power supply to make sure they are properly tuned for an application.

### ZERO BACKLASH

The PMB Series of Brakes have a spring mounted armature, which eliminates backlash in the brake.

### NO DRAG TORQUE

When brakes are released, an airgap is present which completely releases the armature resulting in zero drag.

### HIGH OPERATING TEMPERATURES

The standard magnetic material used in the brakes can accommodate temperatures up to 140 degrees celsius. If an application requires it, special material is also available on some sizes to accommodate higher temperatures.



PMB

# PMB

## PM / EM Power-Off Brake

Types: 3, 4, 5, 7, 9, 11

[ PM: Permanent Magnet ] [ EM: Electromagnet ]

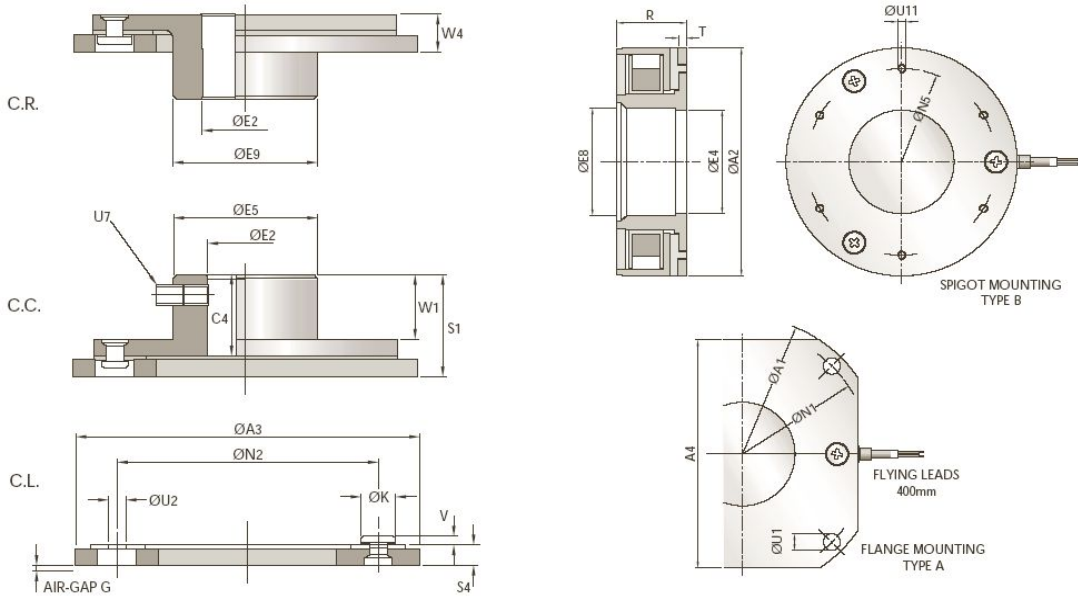

PMB		3*	4*	5*	7*	9*	11*
Static Torque [in-lbs / N-m]		3.5 / 0.4	11 / 1.2	22 / 2.5	44 / 5.0	106 / 12.0	266 / 30.1
Coil (20°C)	Voltage [DC-V]	24					
	Wattage [W]	6	8	12	20	18	22
Bore [mm]	E2H7	8	8	15	20	30	35
Dimensions [mm]	A1h9	38.5	62.5	75	90	115	132
	A2h8	28	40	53	70	85.5	110
	A3	28.5	42	56	73	90	110
	A4	30	45	56	70	90	110
	C4	7.8	14.2	17	20	25	30
	E4H8	16	13	24	30	40	50
	E5	17	16	24	30	40	49
	E8	9	13	24	32	43	52
	E9	-	12	23	30	40	49
	G	0.15	0.15	0.2	0.25	0.25	0.3
	K	4	6	6	8	10	10
	N1	33.5	54	61	79.5	102	121
	N2	19.5	29	46	60	76	95
	N5	22	32.5	48	61	75	90
	R	16	21	20.9	25.3	26.6	33
	S1	10.5	17.5	20.5	24.2	30	36.2
	S4	2.7	3	3.6	4.2	5	6.2
	T	1.5	3	3	3.5	3.5	3.75
	U1	2.6	3.5	4.5	5.5	6.5	6.5
	U2	2.15	3.2	3.1	4.1	5.1	6.1
U7	M3	M3	M5	M5	M5	M6	
U11	M2	M2	M3	M3	M3	M4	
V	1.6	1.5	1.5	1.5	2	4.7	
W1	5.3	12.2	13.5	15	20	24	
W4	-	5.3	7	9.2	10	12.2	
Weight [lbs / kg]		0.18 / 0.08	0.36 / 0.16	0.65 / 0.29	1.2 / 0.5	2.4 / 1.1	4.2 / 1.9

[ 1" = 25.4mm ]

\* When ordering PM brakes select one of two different fields (A,B) and one of three different armatures (CL, CC, CR).  
Example: for type 3 with an external field and a set screw hub (PMB-3-A-CC-24V).

# OPL

S E R I E S

## PERMANENT-MAGNET MAGNETIC PARTICLE TORQUE

Torque Range: 0.89 ~ 3.5 in-lbs

Torque Range: 0.1 ~ 0.4 N-m



## FEATURES

### ACCURATE TORQUE

The drag torque is produced by means of a hysteresis principle. This allows for constant torque levels and eliminates the possibility of high break away torque that occurs with typical friction devices.

### LONG OPERATIONAL LIFE

Permanent magnets and magnetic particles transmit torque, therefore, wear is virtually eliminated.

### AVAILABLE IN TWO TYPES

The standard OPL units (N type) come with an integral shaft. This shaft can be lengthened, shortened or adapted to suit a customer's requirements, such as D cuts, snap ring grooves and others. The shaft material is 400 series stainless steel.

The second option is for OPL units to be supplied with a thru-bore (R type). Smaller bore units are available in 6mm and 8mm, larger units are only available with an 8mm bore.

### STABLE TORQUE

A virtual consistent torque is maintained because of the hysteresis principle and is consistent within allowable speed range.

### EASY INSTALLATION WITH NO ADJUSTMENTS

Units are provided pre-assembled to a specific torque range so there is nothing to adjust.

### BEARING AND BUSHING STYLES AVAILABLE

For slower speeds and lighter loads bushing units are the most cost effective option. However, ball bearing (B) units are available if required by application speed or loading.

### NO CONTAMINATION

Units are sealed which prevents any particles from contaminating the machine, and also prevents contamination of the clutch by the machine environment.



OPL-N



OPL-BN

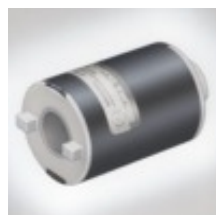

OPL-R



OPL-BR

# OPL-N

## PM Magnetic Particle Torque Limiter

Types: 0.3, 0.6, 1.2, 1.8

[ PM: Permanent Magnet ]

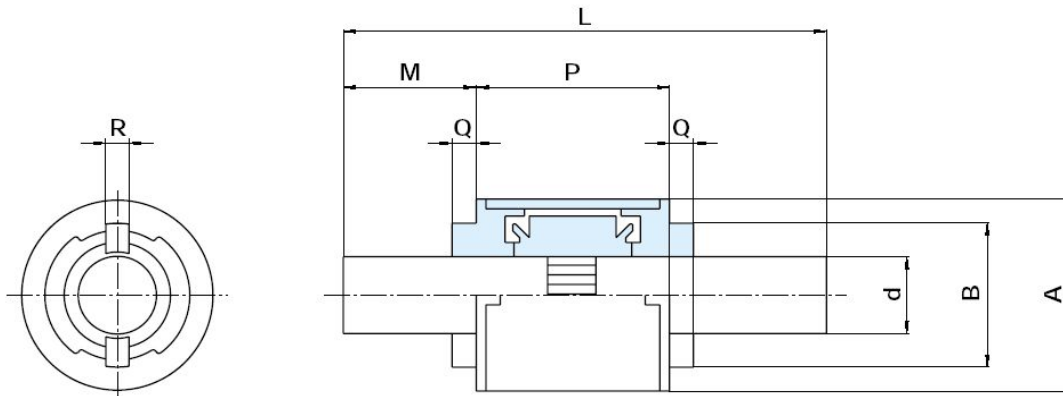

[ Special Order ]

OPL		0.3N	0.6N	1.2N	1.8N
Static Torque [in-lbs / N-m]		0.27 / 0.03	0.53 / 0.06	1.1 / 0.12	1.6 / 0.18
Optional Torque Range [in-lbs]		0.17~0.35	0.35~0.53	0.53~1.06	1.06~1.60
Optional Torque Range [N-m]		0.02~0.04	0.04~0.06	0.06~0.12	0.12~0.18
Max Slip Speed [rpm]		300	300	250	200
Shaft [mm]	d+0/-0.03	8	8	8	8
Dimensions [mm]	A	20	20	20	20
	B	15	15	15	15
	L	180	180	180	180
	M	50	50	50	50
	P	20	20	27	34
	Q	2.5	2.5	2.5	2.5
	R	2.4	2.4	2.4	2.4
Weight [lbs / kg]		0.19 / 0.09	0.19 / 0.09	0.21 / 0.10	0.23 / 0.10

[ 1" = 25.4mm ]

[\* Note 1: Length or shaft can be modified. Flat or special ring groove can also be added. ]

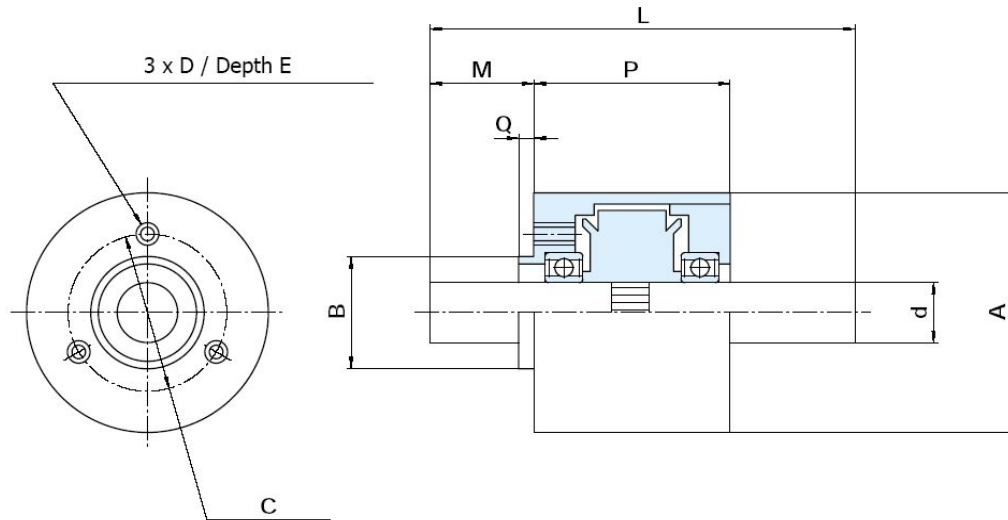

[ Special Order ]

OPL		1BN	1.5BN	2BN	3BN	4BN
Static Torque [in-lbs / N-m]		0.89 / 0.1	1.3 / 0.15	1.8 / 0.2	2.7 / 0.3	3.5 / 0.4
Optional Torque Range [in-lbs]		0.62~0.88	0.88~1.33	1.33~1.76	1.76~2.66	2.66~3.52
Optional Torque Range [N-m]		0.07~0.1	0.1~0.15	0.15~0.2	0.2~0.3	0.3~0.4
Max Slip Speed [rpm]		400	400	300	300	200
Shaft [mm]	d+0/-0.03	8	8	8	8	8
Dimensions [mm]	A	32	32	32	32	32
	Bh8	15	15	15	15	15
	C	21	21	21	21	21
	D	M3	M3	M3	M3	M3
	E	5	5	5	5	5
	L	180	180	180	180	180
	M	50	50	50	50	50
	P	26	26	33	33	40
	Q	2	2	2	2	2
Weight [lbs / kg]		0.35 / 0.16	0.35 / 0.16	0.42 / 0.19	0.42 / 0.19	0.49 / 0.22

[ 1" = 25.4mm ]





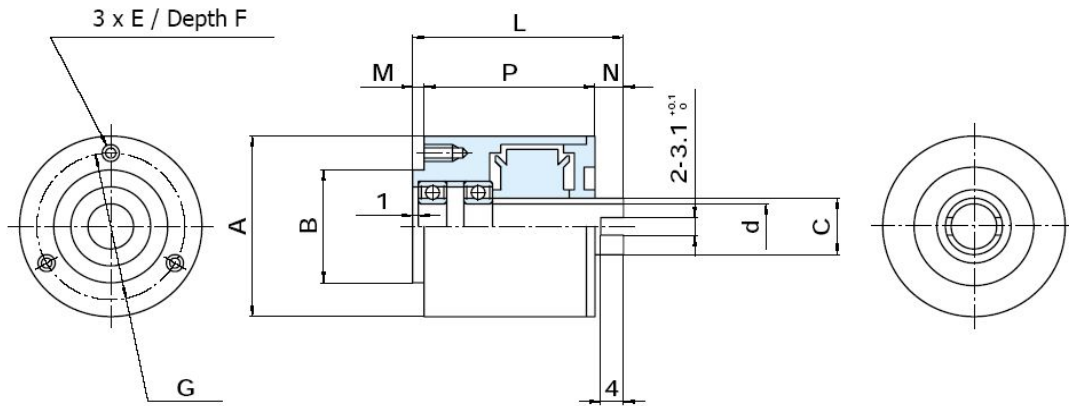

[ Special Order ]

OPL		1BR	1.5BR	2BR	3BR
Static Torque [in-lbs / N-m]		0.89 / 0.1	1.3 / 0.15	1.8 / 0.2	2.7 / 0.3
Optional Torque Range [in-lbs]		0.62~0.88	0.88~1.33	1.33~1.76	1.76~2.66
Optional Torque Range [in-lbs]		0.07~0.1	0.1~0.15	0.15~0.2	0.2~0.3
Max Slip Speed [rpm]		400	400	300	300
Bore [mm]	dH8	8	8	8	8
Dimensions [mm]	A	32	32	32	32
	BH8	20	20	20	20
	C	10	10	10	10
	E	M3	M3	M3	M3
	F	5	5	5	5
	G±0.2	26	26	26	26
	L	37	37	44	44
	M	2	2	2	2
	N	5	5	5	5
P	30	30	37	37	
Weight [lbs / kg]		0.26 / 0.18	0.26 / 0.18	0.33 / 0.15	0.33 / 0.15

[ 1" = 25.4mm ]

# PHT

S E R I E S

## PERMANENT-MAGNET HYSTERESIS TORQUE CONTROLLER

Torque Range: .02 ~ 62 in- lbs

Torque Range: 2.2 ~ 71 in-lbs



## FEATURES

### ACCURATE AND DEPENDABLE TORQUE

Since torque is transmitted via a hysteresis field, there is minimal difference between the static and the dynamic torque. These units are unaffected by friction and wear, therefore torque is substantially more accurate and repeatable than friction tensioners.

### CONSTANT TORQUE (ADJUSTABLE)

Units can deliver set torque regardless of speed range. However, the units set torque can be manually adjusted over a wide range providing great flexibility.

### STABLE TORQUE

A consistent torque is maintained regardless of allowable slip speed due to the hysteresis principle.

### SIMPLE INSTALLATION

Units are provided bearing mounted and pre-assembled.

### LONG LIFE

There is virtually no wear because permanent magnets and hysteresis discs transmit the torque by magnetic flux without physical contact.

### NO CONTAMINATION

Units are sealed to protect against contamination from equipment. There are also no wear particles from operation to contaminate equipment.

### NO ELECTRICAL POWER NEEDED

The PHT series clutches and brakes operate on a permanent magnet principle. External electrical connection is not required, therefore, units function independently from power fluctuation.

### VERTICAL AND HORIZONTAL OPERATION

Units can be mounted in any axis and can be run either clockwise or counter-clockwise without affecting performance.



PHT-S



PHT-D

# PHT-D

## PM Hysteresis Torque Controller

Types: 0.02, 0.05, 0.5

[ PM: Permanent Magnet ]

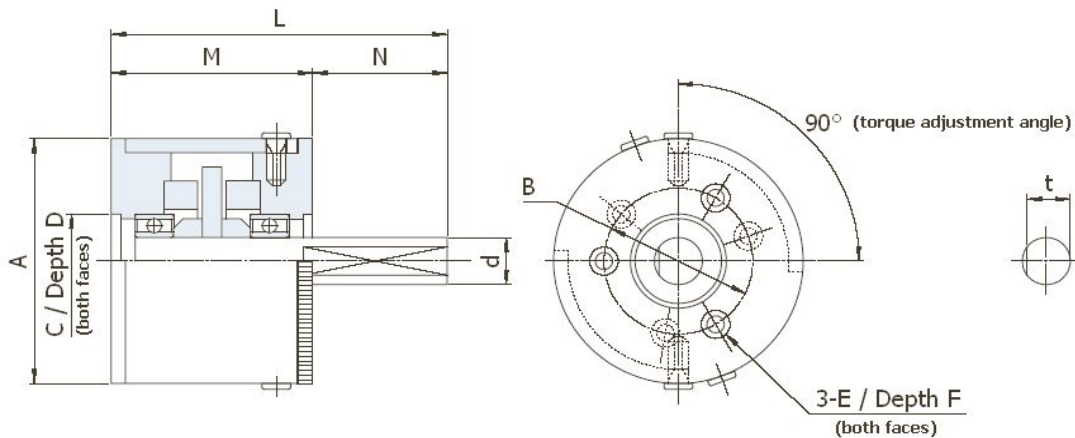

PHT		0.02D	0.05D	0.5D
Torque Range [in-lbs]		0.0049 ~ 0.031	0.012 ~ 0.062	0.089 ~ 0.44
Torque Range [gf-cm]		5.6 ~ 35.7	14.3 ~ 71.4	102 ~ 509.9
Max Slip Speed [rpm]		3600	3600	3600
Max Slip Wattage [W]		1.32	2.65	9.2
Moment of Inertia (J) [kg-cm <sup>2</sup> ]	Body	0.04	0.04	0.19
	Shaft	0.0009	0.0028	0.0375
Shaft [mm]	dh7	5	5	8
	t	4.5	4.5	7.7
Dimensions [mm]	A	26	26	36
	B	15.5	15.5	24
	CH7	10	10	14
	D	1	1	2
	E	M3	M3	M3
	F	4.5	4.5	5.5
	L	35	35	45
	N	14	14	19.5
Weight [lbs / kg]		0.11 / 0.05	0.12 / 0.05	0.32 / 0.15

[ 1" = 25.4mm ]

# PHT-D

## PM Hysteresis Torque Controller

Types: 1.2, 2.5, 5, 10, 30, 70

[ PM: Permanent Magnet ]

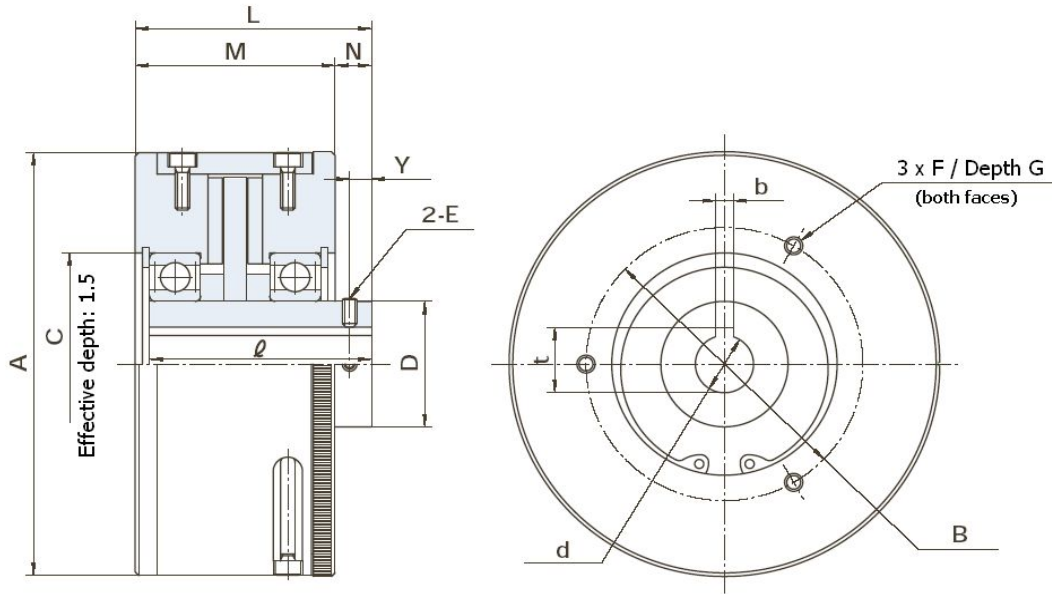

PHT		1.2D	2.5D	5D	10D	30D	70D
Torque Range [in-lbs]		0.18 ~ 1.8	0.44 ~ 3.5	0.44 ~ 6.6	1.8 ~ 13	2.7 ~ 27	6.2 ~ 62
Torque Range [N-m]		0.020 ~ 0.203	0.050 ~ 0.395	0.050 ~ 0.746	0.203 ~ 1.469	0.305 ~ 3.051	0.701 ~ 7.005
Max Slip Speed [rpm]		1800	1800	1800	1800	1000	700
Max Slip Wattage [W]		15	20	30	45	70	150
Moment of Inertia (J) [kg-cm <sup>2</sup> ]	Body	1.3	4.5	7.5	11.5	55	230
	Shaft	0.078	0.243	0.4	1.075	6.25	27.5
Bore [mm]	dH7	6	6	8	15	16	16
	Length	37.5	40	43	53.7	61	64
Key Way [mm]	bjs9	-	-	3	5	5	5
	t+0.1/-0	-	-	9.4	17.3	18.3	18.3
Dimensions [mm]	A	47	60	70	82	118	166
	B	32	40	46	60	76.2	105
	CH7	22	28	28	47	62	62
	D	18	12	15	25	35	35
	E	M3	M3	M3	M4	M4	M4
	F	M3	M3	M3	M4	M5	M5
	L	39.5	42	45	57.2	65	68
	M	32.5	35	37	50.1	55	59
	N	7	7	8	7.1	10	9
	T	6	6	6	10	12	12
Weight [lbs / kg]		0.66 / 0.30	1.3 / 0.6	1.9 / 0.9	3.5 / 1.6	7.9 / 3.6	17 / 8

[ 1" = 25.4mm ]

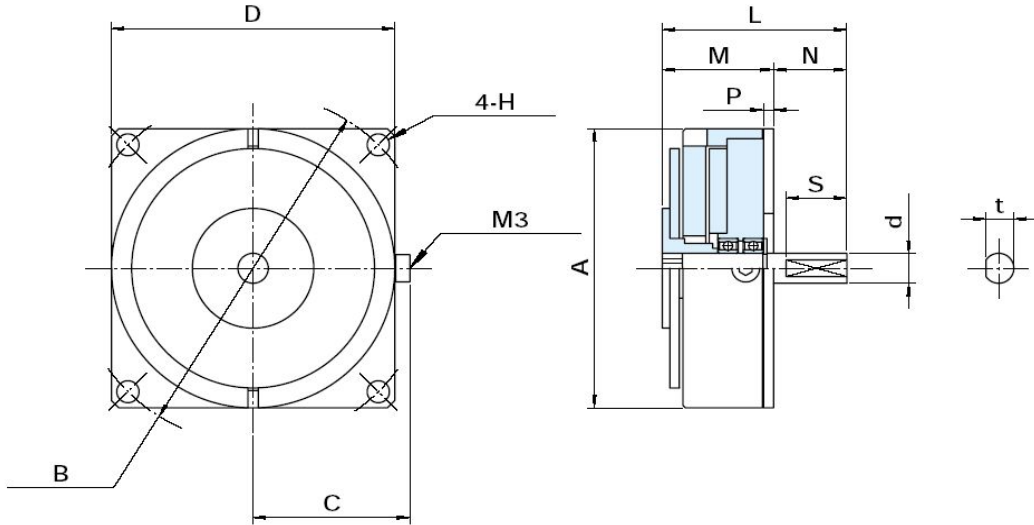

PHT		0.02S	0.05S	0.5S
Torque Range [in-lbs]		0.0044 ~ 0.027	0.0044 ~ 0.066	0.0089 ~ 0.49
Torque Range [gf-cm]		5.1 ~ 30.6	5.1 ~ 76.5	10.2 ~ 560.8
Max Slip Speed [rpm]		10000	10000	1800
Max Slip Wattage [W]		2.5	3	10
Moment of Inertia (J) [kg-cm <sup>2</sup> ]		0.0011	0.0048	0.103
Shaft [mm]	d	3	3	6
	t	2.6	2.6	5.5
Dimensions [mm]	A	26	32	56
	B	34	40	70
	C	16.5	19.5	31.5
	D	30	35	56
	H	3.4	3.4	4.4
	L	28	28	36.5
	M	16.7	18	22
	N	11.3	10	14.5
	P	2	2	2
	S	8	8	12
Weight [lbs / kg]		0.13 / 0.06	0.2 / 0.1	0.8 / 0.3

[ 1" = 25.4mm ]

# PHT: TYPICAL INSTALLATION

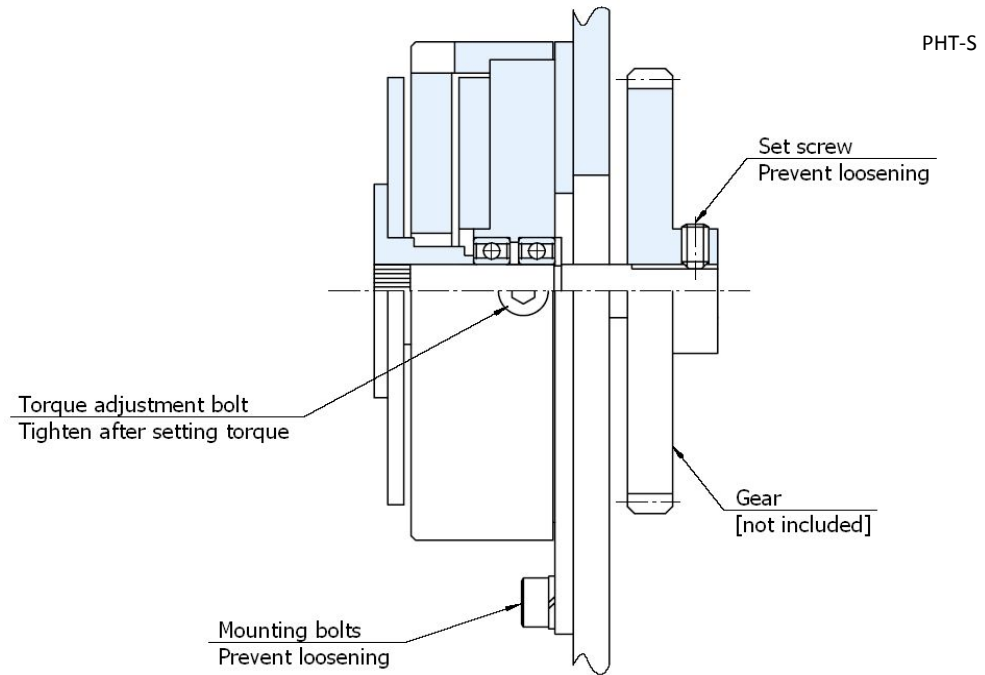
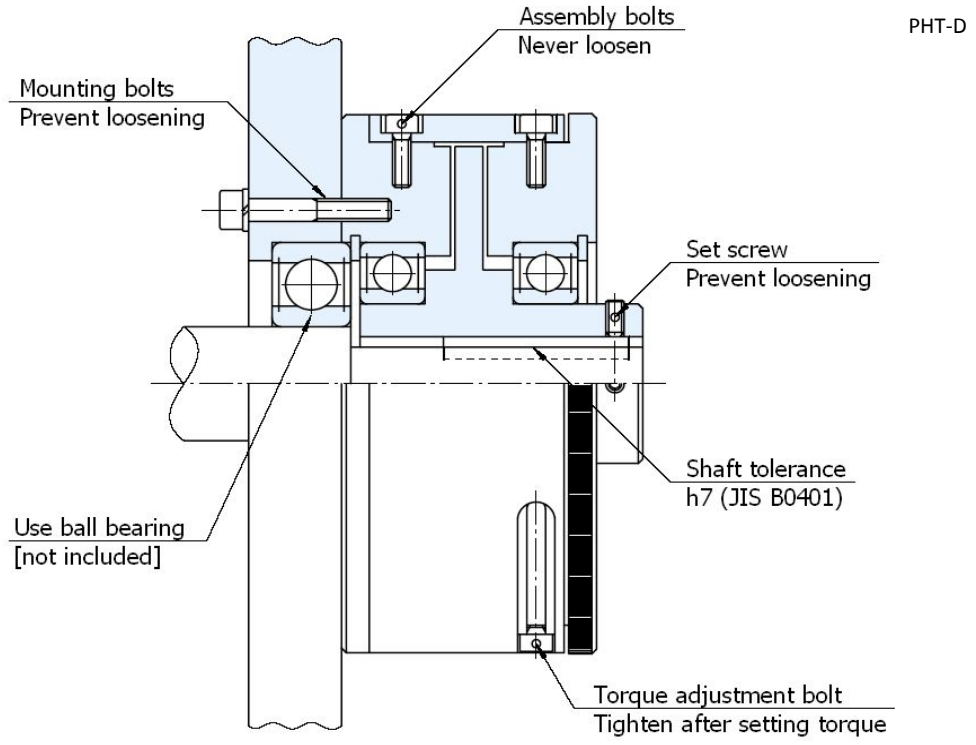

# PHT: TORQUE ADJUSTMENT

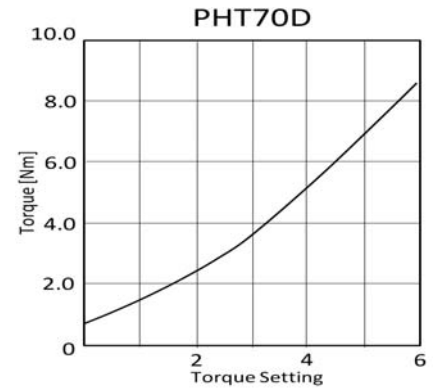
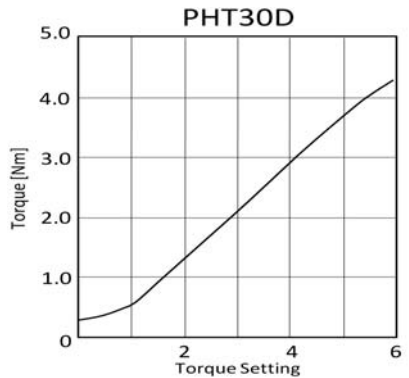
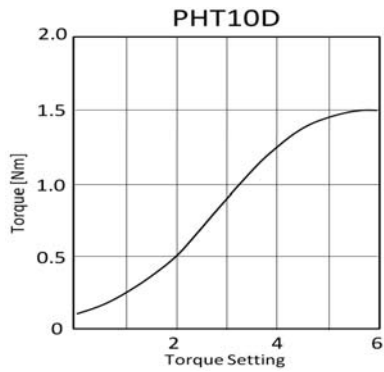
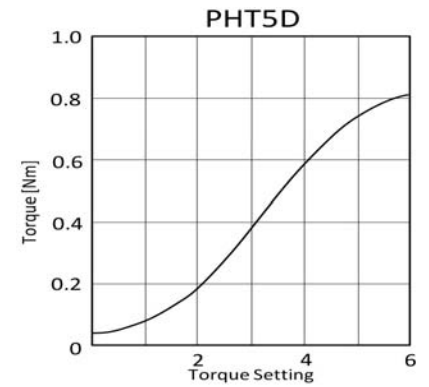
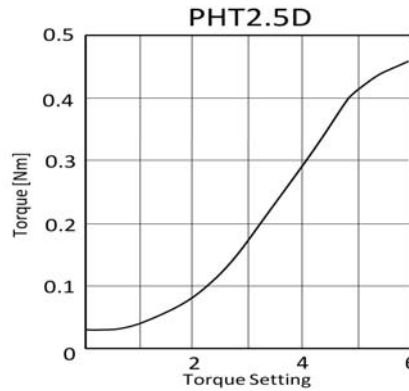
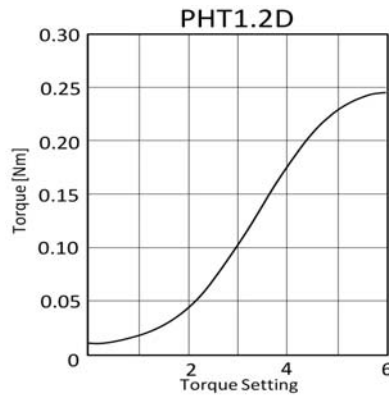
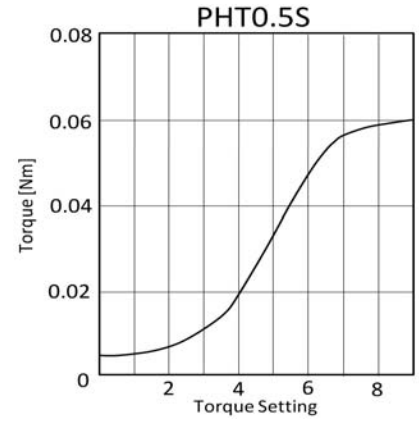
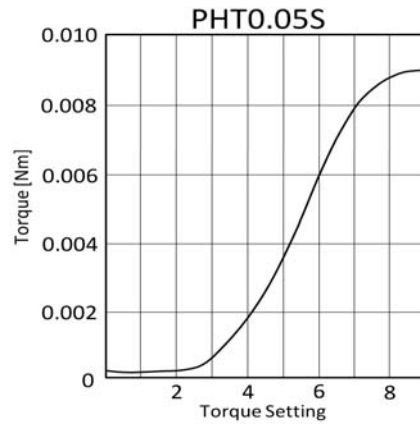
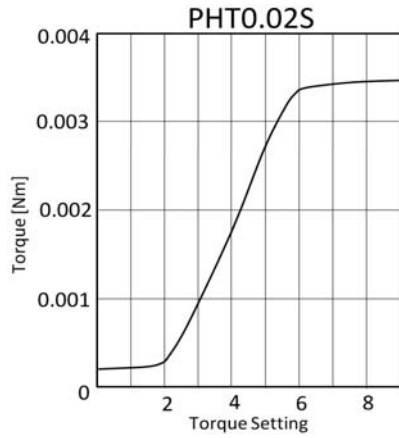

Torque Set Gage

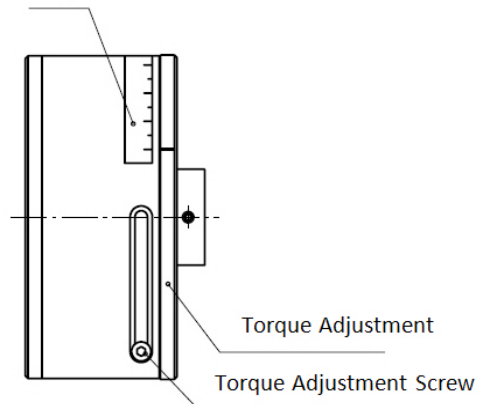



# PET

S E R I E S

## PERMANENT-MAGNET EDDY-CURRENT TORQUE CONTROLLER

Torque Range ~ .02 in-oz / rpm

Torque Range: 2.2 ~ 71 in-lbs



## FEATURES

### ACCURATE AND DEPENDABLE TORQUE

Torque is transmitted via a hysteresis field resulting in consistent torque over time. Units are unaffected by friction and wear, therefore torque is substantially more accurate and repeatable than friction tensioners.

### ADJUSTABLE TORQUE GAIN

Each unit's torque setting may be manually adjusted over a wide range, providing torque ramp flexibility.

### NO ELECTRICAL POWER NEEDED

The PET series clutches and brakes operate on a permanent magnet principle. External electrical connection is not required, therefore, units function independently from power fluctuation.

### NO CONTAMINATION

Units are sealed to protect against contamination from equipment. There are also no wear particles from operation to contaminate other equipment.

### TORQUE PROPORTIONAL TO SPEED

Unlike centrifugal clutches that use friction surfaces, there are no sudden changes in torque. The torque that is generated is proportional to the change in rpm, giving a smooth acceleration.

### LONG LIFE

There is virtually no wear because permanent magnets and hysteresis disks transmit the torque by magnetic flux without physical contact.

### SIMPLE INSTALLATION

Units are bearing-mounted and pre-assembled.

### VERTICAL OR HORIZONTAL OPERATION

Units can be mounted in any axis and can be run either clockwise or counterclockwise without affecting performance.

### RESISTANT TO TEMPERATURE VARIATION

Rare earth magnets are employed in the design, which develop high torque while remaining unsusceptible to temperature variation.

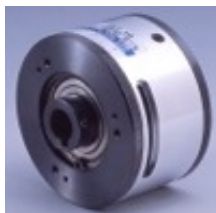

PET

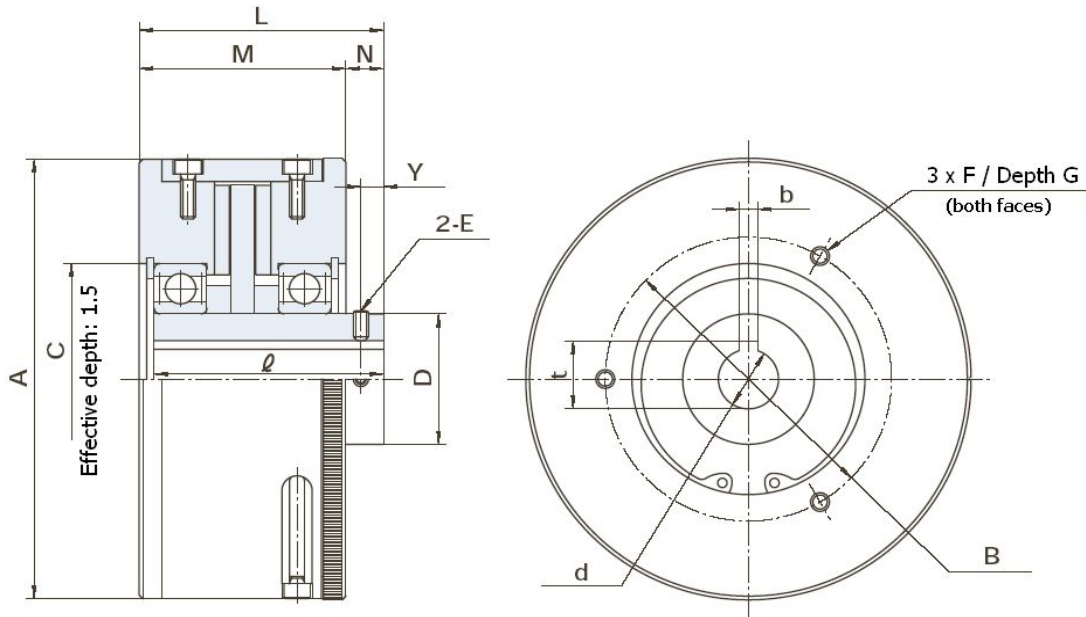

[ Special Order ]

PET		1.2	2.5	5	10
Torque Gain [in-lbs/rpm]		0.00018 ~ 0.00062	0.00044 ~ 0.0019	0.00044 ~ 0.0040	0.0013 ~ 0.0089
Torque Gain [gf-cm/rpm]		0.207 ~ 0.714	0.507 ~ 2.189	0.507 ~ 4.609	1.498 ~ 10.254
Max Slip Speed [rpm]		1800	1800	1800	1800
Max Slip Wattage [W]		9	9	10	14
Moment of Inertia (J) [kg-cm <sup>2</sup> ]	Body	0.7	2.05	4.08	11.43
	Shaft	0.078	0.22	0.35	1.05
Bore [mm]	dH7	6	6	8	15
	Length	35	36.2	39.6	51.5
Key Way [mm]	bJs9	-	-	3	5
	t+0.1/-0	-	-	9.4	17.3
Dimensions [mm]	A	47	60	70	82
	B	32	40	46	60
	CH7	22	28	28	47
	D	18	12	15	25
	E	M3	M3	M3	M4
	F	M3	M3	M3	M4
	L	38	39.2	42.6	55
	M	31	32.2	34.6	47.9
	N	7	7	8	7.1
	T	6	6	6	10
Y	3	3	4	3.5	
Weight [lbs]		0.66 / 0.30	1.1 / 0.5	1.7 / 0.8	3.2 / 1.5

[ 1" = 25.4mm ]

# PET: TORQUE CHARACTERISTIC

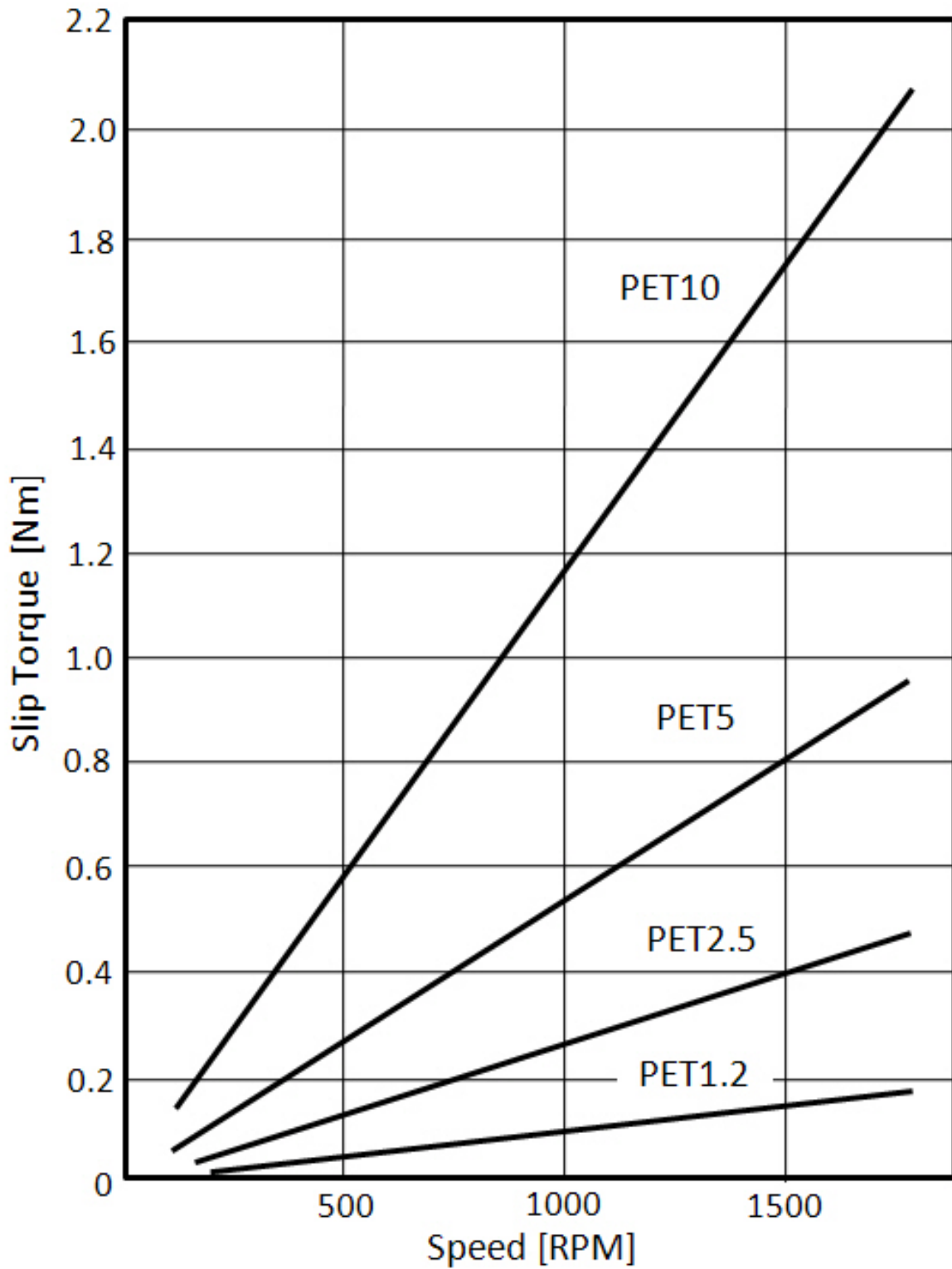

# OP

S E R I E S

## ELECTROMAGNETIC MAGNETIC PARTICLE CLUTCH & BRAKE

Torque Range: 4.4 ~ 71 in-lbs

Torque Range: 0.5 ~ 8 N-m



## FEATURES

### FAST RESPONSE

The OP series has been designed to provide fast response. Response rates can be further quickened through overexcitation circuits.

### SLIP CAPACITY

OP series units are designed to deliver high performance under constant slip conditions.

### NO CONTAMINATION

Units are sealed which prevents any wear particles from contaminating the machine, and also prevents contamination of the clutch by the machine environment.

### STABLE TORQUE

The OP series produce consistent and repeatable torque. Torque is independent of speed and proportional to voltage applied to the field.

### LONG LIFE

The OP series unit's sturdy construction and precise formulation of the magnetic particles combine to provide extended life.



OPB-N



OPC

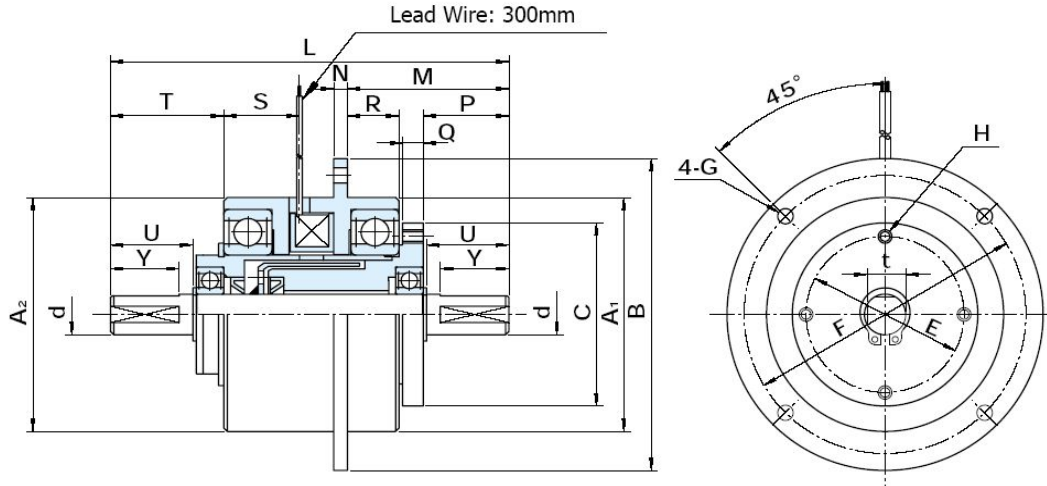

OPC		5	10	20
Rated Torque [in-lbs / N-m]		4.4 / 0.5	8.9 / 1	18 / 2
Coil (20°C)	Voltage [DC-V]	24		
	Current [A]	0.48	0.58	0.75
	Resistance [Ω]	50	41	32
	Wattage [W]	12	14	18
	Time Constant [ms]	11	15	18
Drag Torque (reference) [in-lbs]		0.089	0.18	0.35
Max Slip Wattage [W]		15	25	45
Max Allowable Speed [rpm]		1800	1800	1800
Moment of Inertia (J) [kg-cm <sup>2</sup> ]	Input	0.153	0.258	0.838
	Output	0.014	0.018	0.07
Shaft [mm]	dh7	5	7	12
	t	4.5	6.5	11.5
Dimensions [mm]	A1h8	50	54	69
	A2	50	54	69
	B	70	76	92
	Ch7	40	42	54
	E	30	34	46
	F	60	66	82
	G	4.5	4.5	4.5
	H	3xM4	3xM4	4xM4
	L	77	83	116
	M	25	27	47
	N	4	4	4
	P	11	13	25
	Q	5	5	6
	R	8.5	8.5	15
	S	25.5	18	22
T	13.5	15.5	33	
U	10.5	12.2	24	
Y	9	10	20	
Weight [lbs / kg]		1.5 / 0.7	1.8 / 0.8	2.9 / 1.3

[ 1" = 25.4mm ]

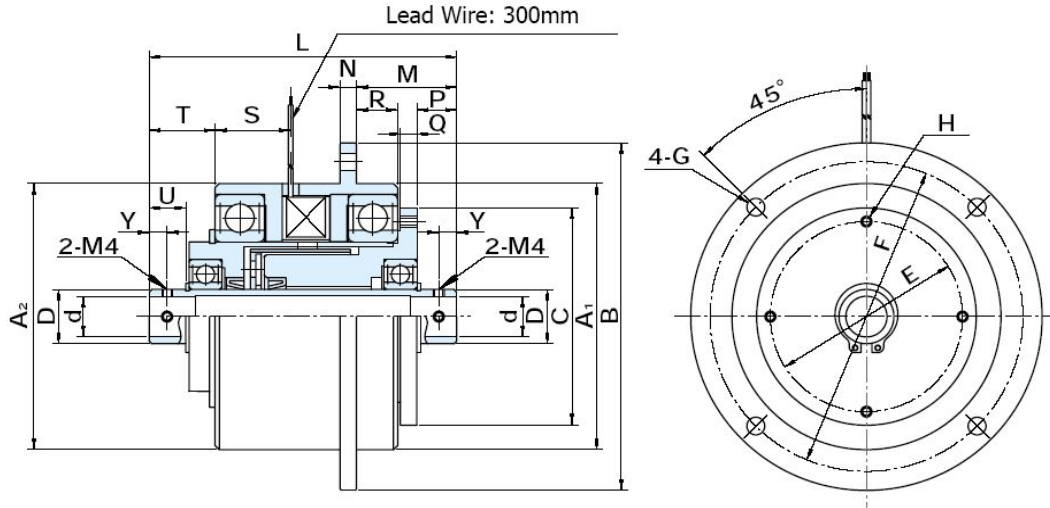

OPC		40	80
Rated Torque [in-lbs / N-m]		35 / 4	71 / 8
Coil (20°C)	Voltage [DC-V]	24	
	Current [A]	0.93	1.37
	Resistance [Ω]	26	17.6
	Wattage [W]	22	33
	Time Constant [ms]	25	50
Drag Torque (reference) [in-lbs]		0.71	1.4
Max Slip Wattage [W]		70	90
Max Allowable Speed [rpm]		1800	1800
Moment of Inertia (J) [kg-cm <sup>2</sup> ]	Input	3.25	5.25
	Output	0.288	0.388
Shaft [mm]	dH7	12	15
Dimensions [mm]	A1h8	86	98
	A2	86	98
	B	112	128
	Ch7	70	80
	D	20	20
	E	60	70
	F	100	114
	G	5.5	6.5
	H	4xM4	4xM4
	L	97	112
	M	32	36.5
	N	5	6
	P	10	14.5
	Q	6	6
	R	15	15
	S	25	27.5
	T	21	24
U	8.8	13.3	
Y	4	6.5	
Weight [lbs / kg]		5.3 / 2.4	6.8 / 3.1

[ 1" = 25.4mm ]

## OPC: TYPICAL INSTALLATION

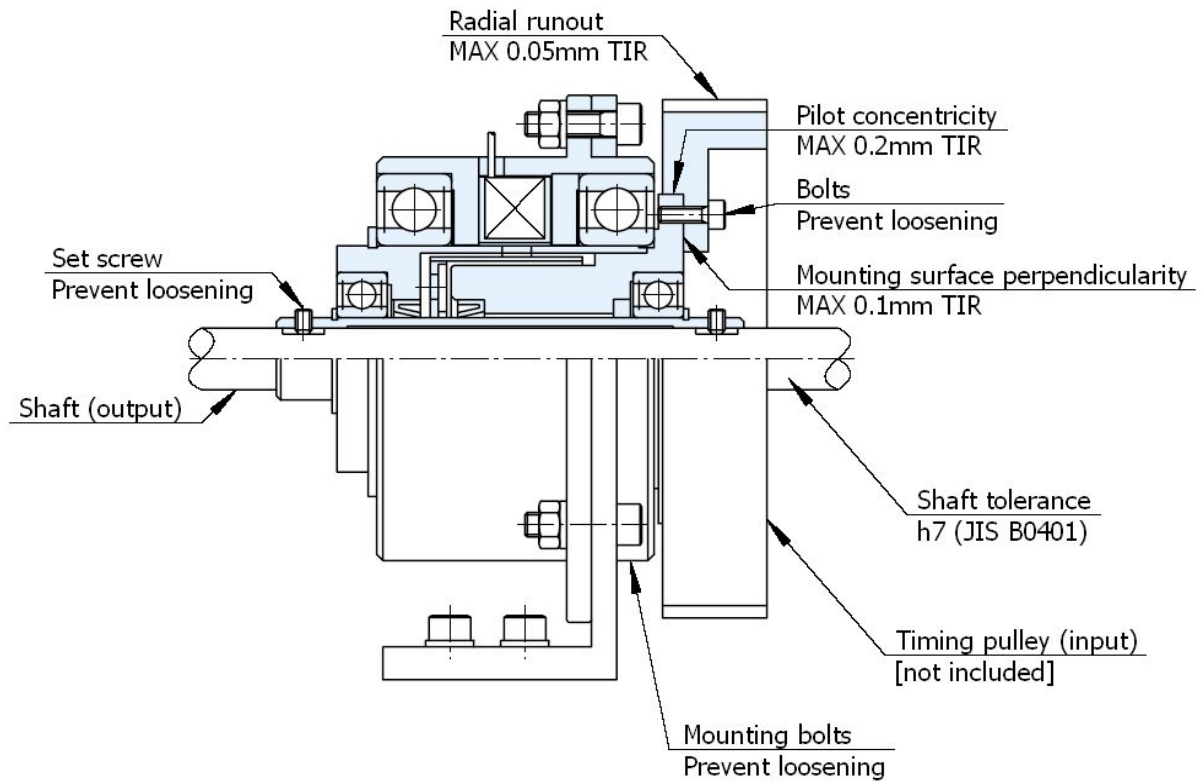

## OPC: TORQUE CHARACTERISTIC

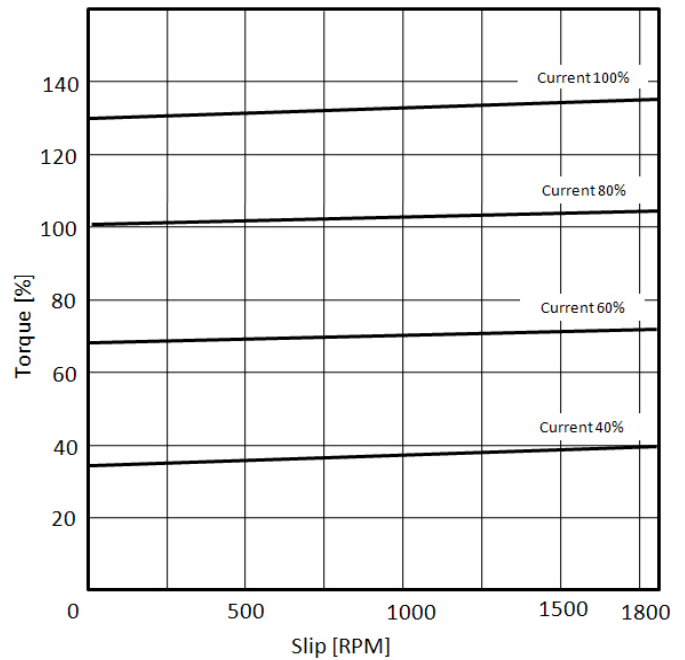
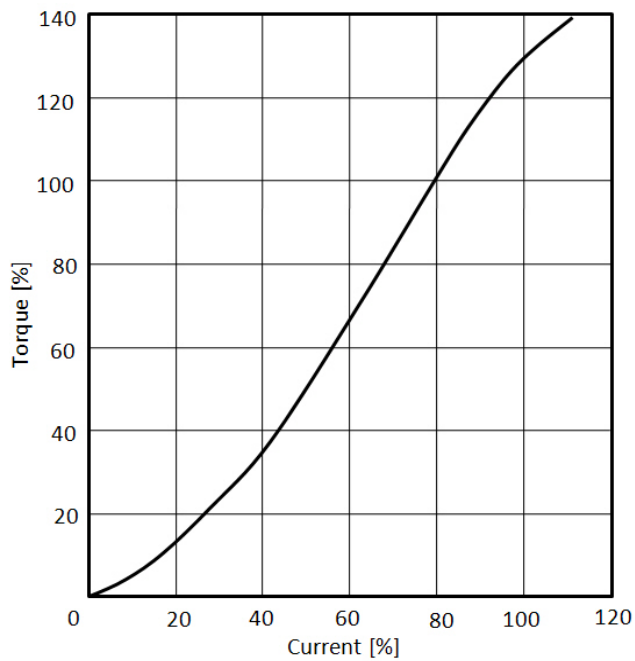



# OPB-N

# EM Magnetic Particle Brake

Types: 5, 10, 20, 40, 80

[ EM: Electromagnet ]

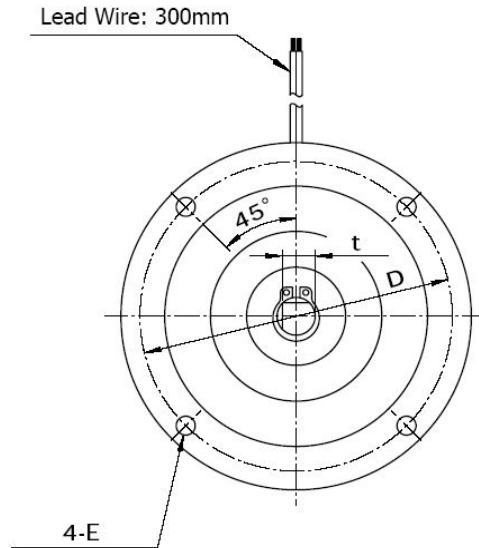
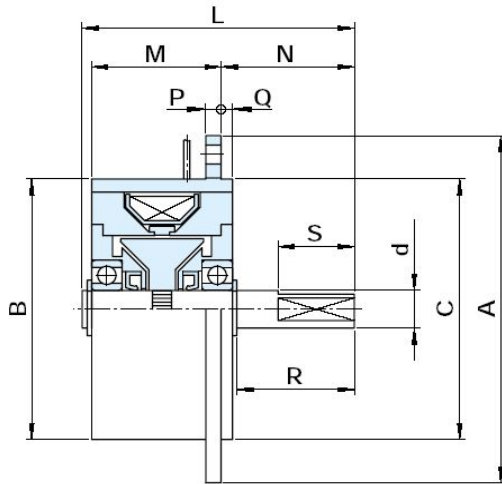

OPB		5N	10N	20N	40N	80N
Rated Torque [in-lbs / N-m]		4.4 / 0.5	8.9 / 1	18 / 2	35 / 4	71 / 8
Coil (20°C)	Voltage [DC-V]	24				
	Current [A]	0.27	0.37	0.37	0.37	0.37
	Resistance [Ω]	90	65	65	65	65
	Wattage [W]	6.4	9	9	9	9
	Time Constant [ms]	17	27	23	50	74
Drag Torque (reference) [in-lbs]		0.089	0.18	0.35	0.71	1.4
Max Slip Wattage [W]		25	35	50	60	80
Max Allowable Speed [rpm]		1800	1800	1800	1800	1800
Moment of Inertia (J) [kg-cm <sup>2</sup> ]		0.025	0.055	0.358	0.94	3.53
Shaft [mm]	dg7	6	7	10	12	15
	t	5.5	6.5	9	10	13
Dimensions [mm]	A	65	75	92	112	128
	B	46	56	69	86	100
	Ch9	43	54	69	86	98
	D	56	66	82	100	114
	E	4.5	4.5	4.5	5.5	6.5
	L	56	61	71.5	79	95
	M	27.5	33	34	36	42
	N	25.5	25.8	35	40	50
	P	3	4	4	5	6
	Q	2.5	3	3	5	6
	R	22.3	22	31	34	43
S	12	12	20	20	20	
Weight [lbs / kg]		0.88 / 0.40	1.5 / 0.7	2.2 / 1.0	4.0 / 1.8	6.6 / 3.0

[ 1" = 25.4mm ]

# OPB-N: TYPICAL INSTALLATION

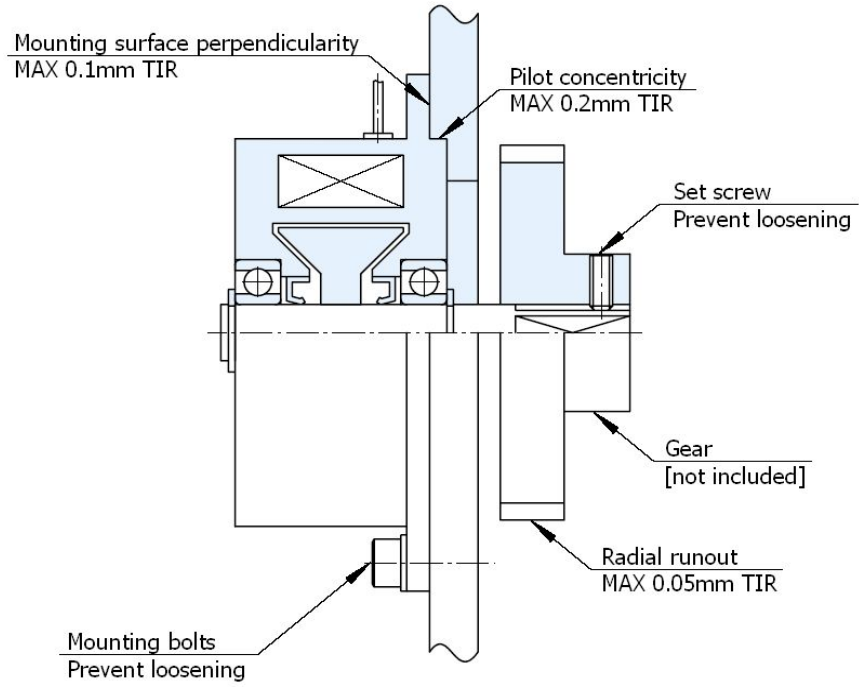

# OPB-N: TORQUE CHARACTERISTIC

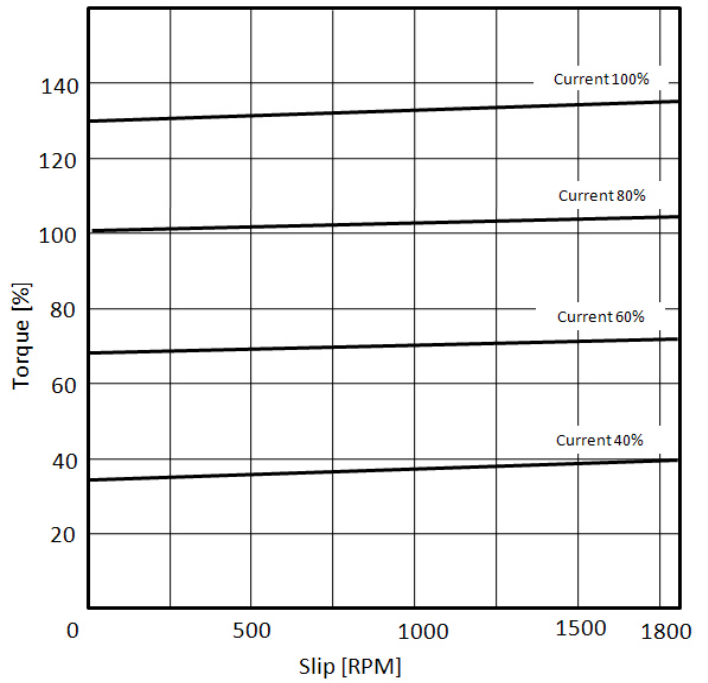
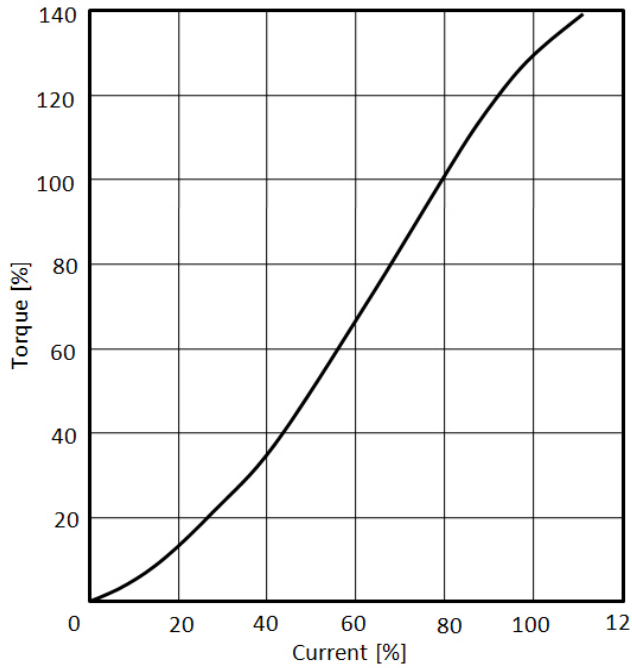

# PB/PC

S E R I E S

## ELECTROMAGNETIC MAGNETIC PARTICLE CLUTCH & BRAKE

Torque Range: 8.9 ~ 148 ft-lbs

Torque Range: 12 ~ 200 N-m

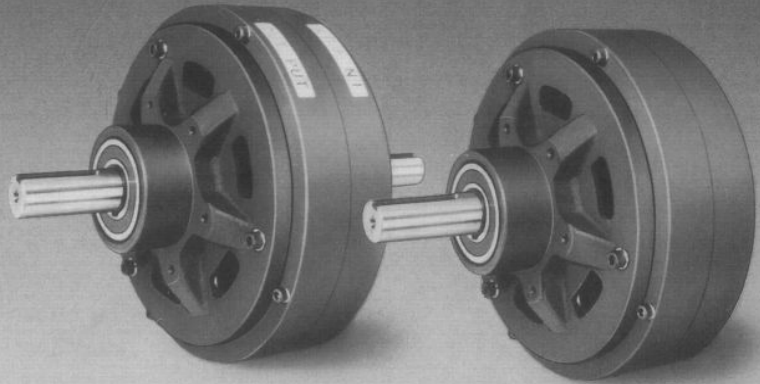

## FEATURES

### RELIABLE AND STABLE TORQUE

The PB/PC series have been designed to maintain high performance in continuous slip applications within their heat dissipation range.

### FORCED AIR COOLING

Units come equipped with inlets and outlets for forced air. Forced air cooling provides additional heat dissipation if warranted by the application. In general forced air cooling can double the heat dissipation.

### HIGH CYCLE CAPABILITY AND LONG LIFE

The use of high wear resistant particles assures long operational life in high cycle applications.

### DESIGNED FOR CONTINUOUS SLIP

The PB/PC series have been designed to maintain high performance in continuous slip applications through maximum and continuous heat dissipation.

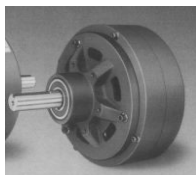

PB



PC

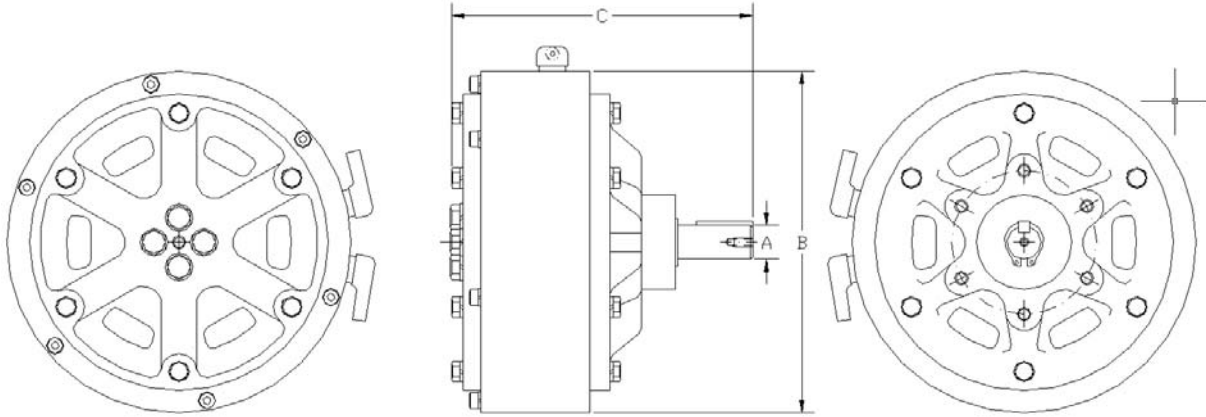

PB		1.2	2.5	5	10	20
Rated Torque [ft-lbs / N-m]		8.9 / 12	18 / 25	37 / 50	74 / 100	148 / 200
Coil (75°C)	Voltage [DC-V]	24				
	Current [A]	1.4	1.9	2.8	3.6	3.8
	Wattage [W]	42	56	82	105	112
Max Allowable Speed [rpm]		1800	1800	1800	1800	1800
Max Natural Heat Dissipation [W]	100rpm	100	130	160	250	350
	1000rpm	100	130	250	400	700
Max Forced Heat Dissipation [W]		200	240	400	800	1400
Air Pressure <sup>1</sup> [kg/cm <sup>2</sup> ]		0.3	0.5	1	1.4	1.5
Air Volume <sup>1</sup> [m <sup>3</sup> /min]		0.2	0.3	0.6	1.1	1.6
A [mm]		15	20	25	30	35
B [mm]		152	182	218	290	335
C [mm]		133	156	195	242	278
Weight [lbs / kg]		15 / 7	24 / 11	39 / 18	88 / 40	141 / 64

[ Note 1 : Air flow specifications for forced heat dissipation ]

[ 1" = 25.4mm ]

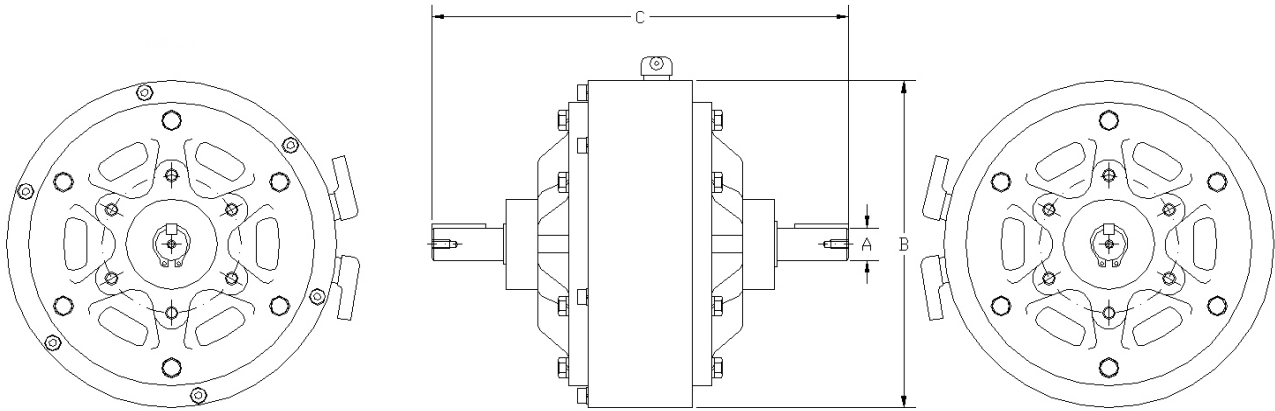

PC		1.2	2.5	5	10	20
Rated Torque [ft-lbs / N-m]		8.9 / 12	18 / 25	37 / 50	74 / 100	148 / 200
Coil (75°C)	Voltage [DC-V]	24				
	Current [A]	1.4	1.9	2.8	3.6	3.8
	Wattage [W]	42	56	82	105	112
Max Allowable Speed [rpm]		1800	1800	1800	1800	1800
Max Natural Heat Dissipation [W]	100rpm	100	130	160	250	350
	1000rpm	100	130	250	400	700
Max Forced Heat Dissipation [W]		200	240	400	800	1400
Air Pressure <sup>1</sup> [kg/cm <sup>2</sup> ]		0.3	0.5	1	1.4	1.5
Air Volume <sup>1</sup> [m <sup>2</sup> /min]		0.2	0.3	0.6	1.1	1.6
A [mm]		15	20	25	30	35
B [mm]		152	182	218	290	335
C [mm]		192	230	294	360	408
Weight [lbs / kg]		17 / 8	28 / 13	43 / 20	94 / 43	158 / 72

[ Note 1 : Air flow specifications for forced heat dissipation ]

[ 1" = 25.4mm ]

# H

S E R I E S

## ELECTROMAGNETIC HYSTERESIS CLUTCH & BRAKES

Torque Range: 1.1 ~ 8.9 in-lbs

Torque Range: 0.12 ~ 1 N-m



## FEATURES

### FAST RESPONSE

The torque of H series electromagnetic hysteresis clutches/brakes is independent of slip speed. Torque is directly proportionate to coil current, thus the torque of each unit can be adjusted by varying the current. Once the current is stable, the torque remains constant.

### LONG LIFE

The H series produces drag torque without physical contact (friction) of parts and are not subject to wear (except the normal wear of antifriction bearings).

### REPEATABILITY

The H series will always duplicate performance under identical operating conditions.

### SMOOTH OPERATION

The H series does not utilize mechanical friction, therefore operation is smooth at any slip speed.

### EASY MOUNTING

Mounting is effortless - no adjustments to make, no gaps to set. The H series may be mounted in the horizontal or vertical position.



HC 0.5



HC 1.2 ~ 10



HB 0.5



HB 1.2 ~ 10

# HB

# EM Hysteresis Brake

Types: 0.5

[ EM: Electromagnet ]

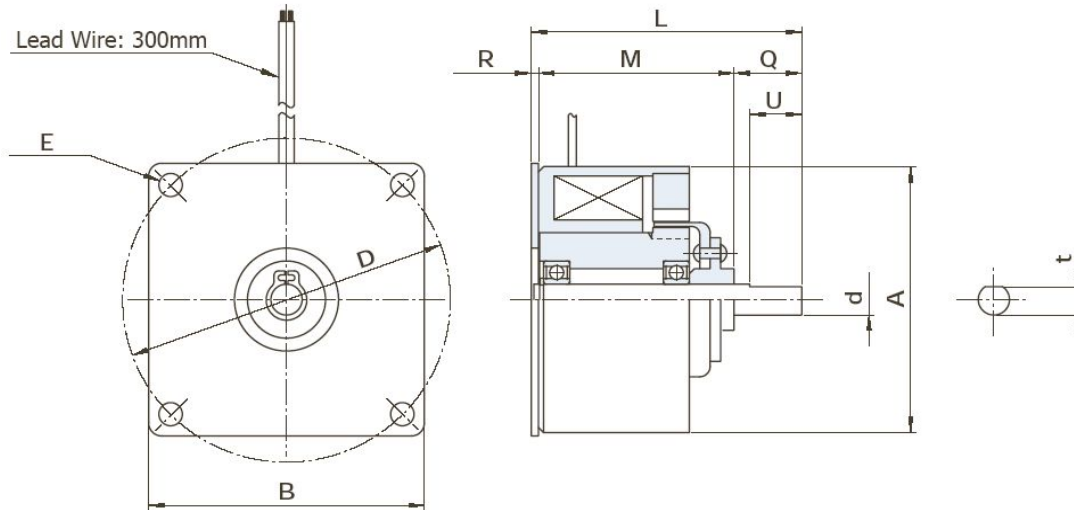

[ Special Order ]

HB		0.5
Rated Torque [in-lbs / N-m]		0.44 / 0.05
Coil (20°C)	Voltage [DC-V]	24
	Current [A]	0.29
	Resistance [ $\Omega$ ]	84
	Wattage [W]	6.9
	Time Constant [ms]	35
Torque Decay (20%) Time [ms]		17
Max Slip Rate [W]		6
Max Allowable Speed [rpm]		3000
Moment of Inertia (J) [kg-cm <sup>2</sup> ]		0.025
Shaft [mm]	dg6	6
	t	5.5
Dimensions [mm]	A	51.7
	B	53
	D	63
	E	4x4.5
	L	52
	M	39
	Q	13
	R	1.4
	U	10
Weight [lbs / kg]		0.88 / 0.40

[ 1" = 25.4mm ]



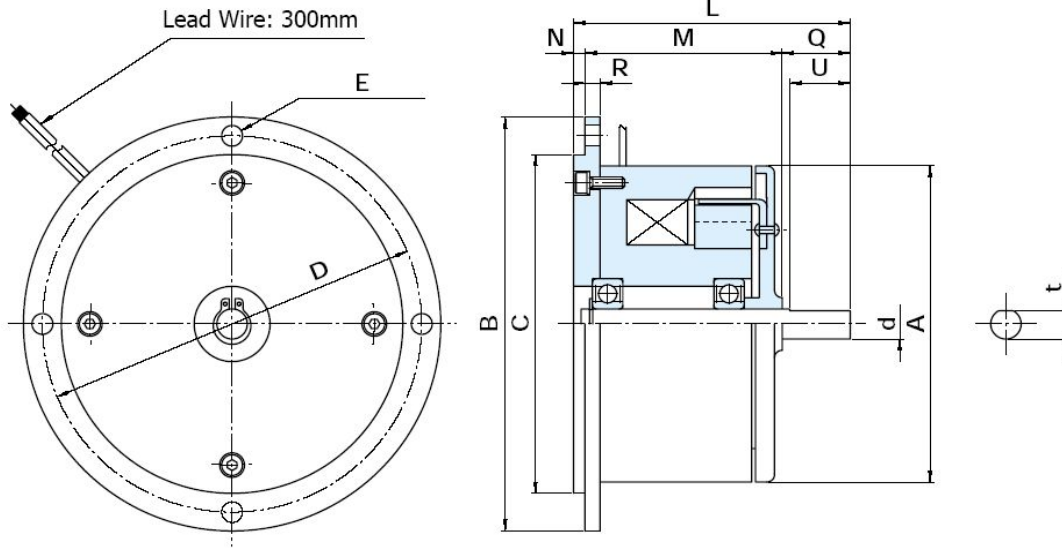

HB		1.2	2.5	5	10
Rated Torque [in-lbs / N-m]		1.1 / 0.12	2.2 / 0.25	4.4 / 0.5	8.9 / 1
Coil (20°C)	Voltage [DC-V]	24			
	Current [A]	0.3	0.43	0.56	0.76
	Resistance [Ω]	78.9	55.7	43	31.6
	Wattage [W]	7.5	10	13	18
	Time Constant [ms]	55	80	100	175
Torque Decay (20%) Time [ms]		10	10	12	15
Max Slip Rate [W]		27	34	40	59
Max Allowable Speed [rpm]		3000	3000	3000	3000
Moment of Inertia (J) [kg-cm <sup>2</sup> ]		0.25	0.425	0.8	2.55
Shaft [mm]	dh7	6	7	8	10
	t	5.5	6.5	7.5	9.5
Dimensions [mm]	A	60	70	84	112
	B	86	98	110	136
	Ch7	66	78	90	112
	D	76	88	100	124
	E	4x5.5	4x5.5	4x5.5	6x5.5
	L	58	63	73	80
	M	42	45	52	55
	N	2	2	3	3
	Q	14	16	18	22
	R	4	4	4	5
	U	12	14	16	20
Weight [lbs / kg]		1.9 / 0.9	2.6 / 1.2	5.1 / 2.3	7.9 / 3.6

[ 1" = 25.4mm ]

## HB: TYPICAL INSTALLATION

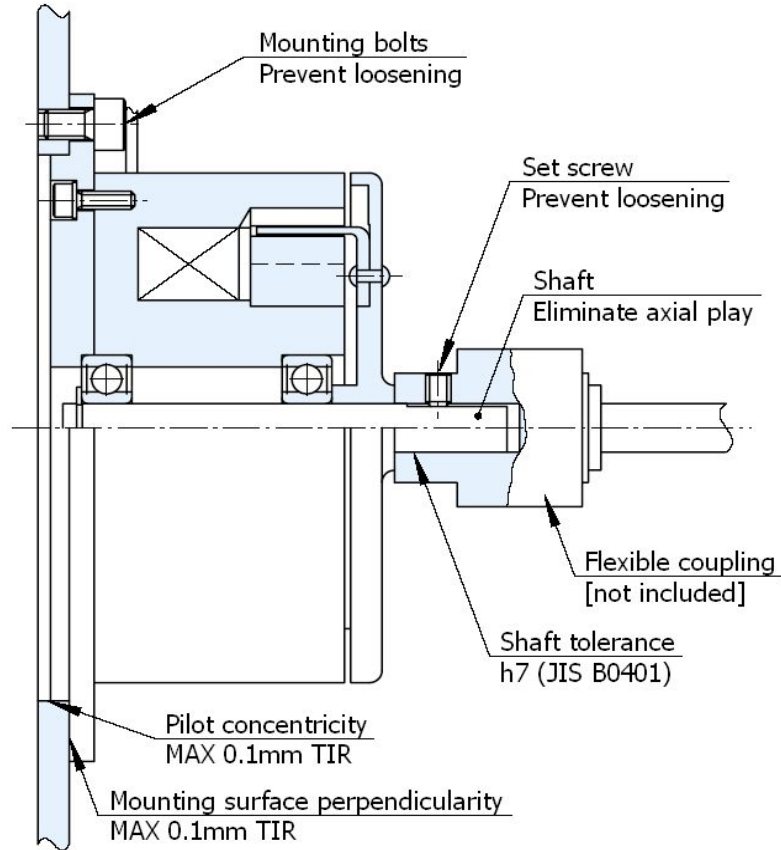

## HB: TORQUE CHARACTERISTIC

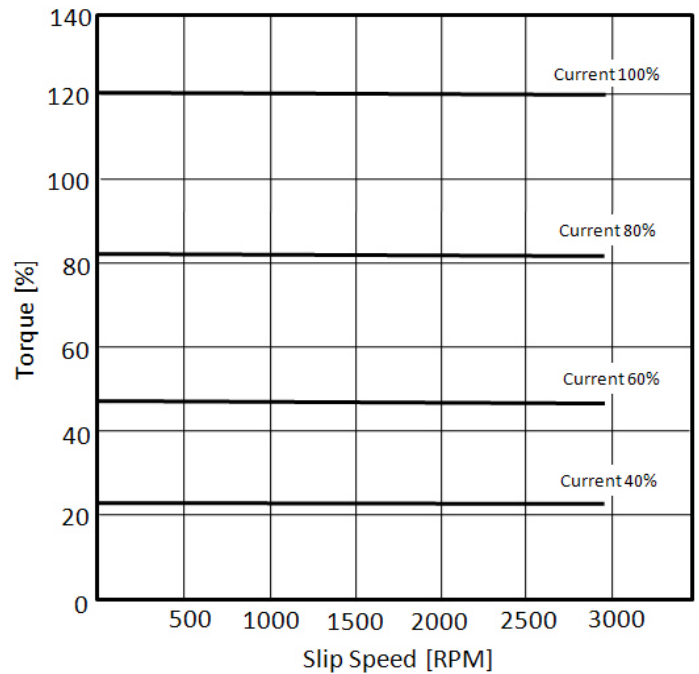
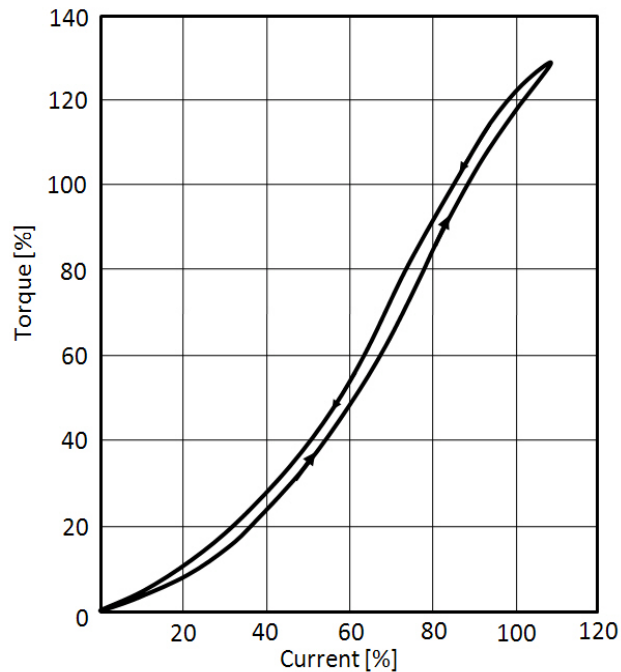

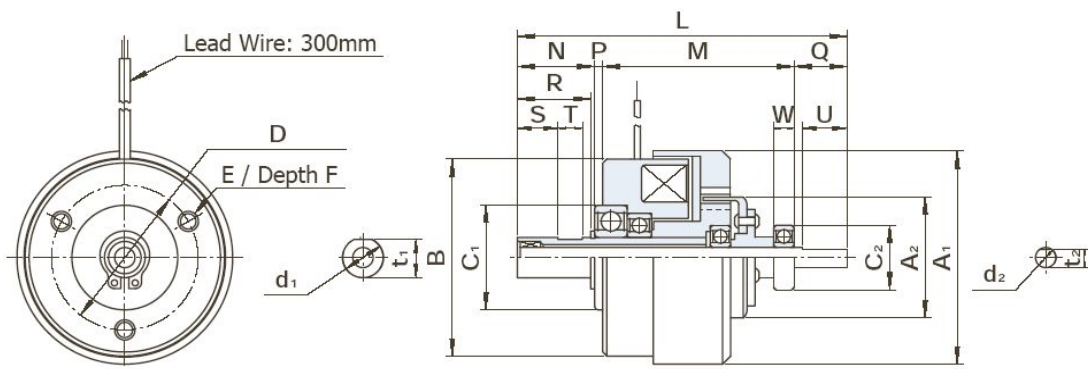

[ Special Order ]

HB		0.5
Rated Torque [in-lbs / N-m]		0.44 / 0.05
Coil (20°C)	Voltage [DC-V]	24
	Current [A]	0.44
	Resistance [ $\Omega$ ]	55
	Wattage [W]	10.5
	Time Constant [ms]	35
Torque Decay (20%) Time [ms]		17
Max Slip Rate [W]		6
Max Allowable Speed [rpm]		3000
Moment of Inertia (J) [kg-cm <sup>2</sup> ]	Rotor	0.6
	Cup	0.025
Shaft [mm]	d1h7	10
	t1	9.5
	d2g6	5
	t2	4.5
Dimensions [mm]	A1	53
	A2	30
	B	49
	C1	26
	C2	16
	D	36
	E	3xM5
	F	5
	L	81
	M	47
	N	19
	P	2
	Q	13
	R	18
	S	10
T	6	
U	11	
W	5	
Weight [lbs / kg]		1.00 / 0.45

[ 1" = 25.4mm ]

# HC

# EM Hysteresis Clutch

Types: 1.2, 2.5, 5, 10

[ EM: Electromagnet ]

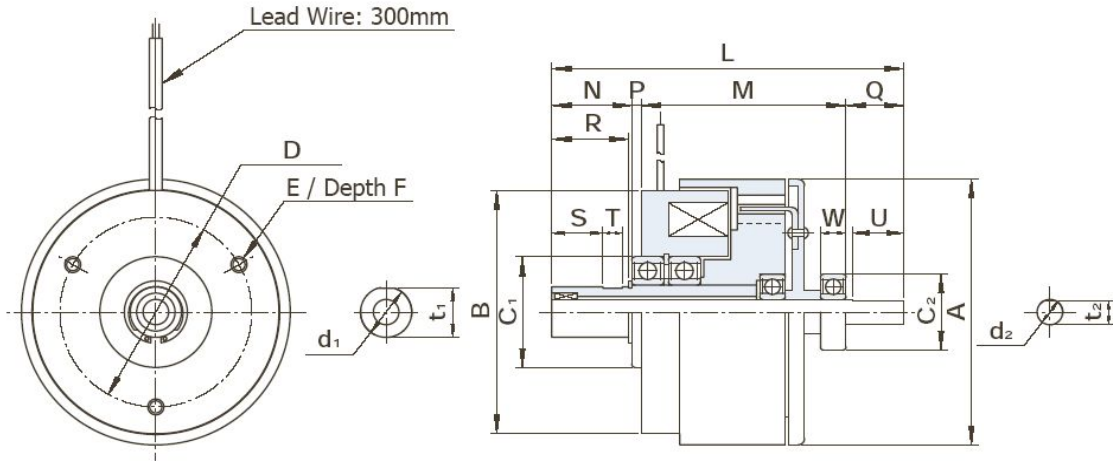

HC		1.2 <sup>1</sup>	2.5	5	10
Rated Torque [in-lbs / N-m]		1.1 / 0.12	2.2 / 0.25	4.4 / 0.5	8.9 / 1
Coil (20°C)	Voltage [DC-V]				
	Current [A]	0.46	0.63	0.71	0.86
	Resistance [Ω]	52.4	38	34	28
	Wattage [W]	11	15	17	21
	Time Constant [ms]	55	80	100	175
Torque Decay (20%) Time [ms]		10	10	12	15
Max Slip Rate [W]		27	34	40	59
Max Allowable Speed [rpm]		3000	3000	3000	3000
Moment of Inertia (J) [kg-cm <sup>2</sup> ]	Rotor	1	3.2	7.25	14.1
	Cup	0.25	0.425	0.8	2.55
Shaft [mm]	d1h7	12	14	16	18
	t1	11.5	13.5	15.5	17.5
	d2h7	6	7	8	10
	t2	5.5	6.5	7.5	9.5
Dimensions [mm]	A	60	70	84	112
	B	56	64.6	77	105
	C1	28	32	35	42
	C2	19	22	24	26
	D	40	50	60	70
	E	3xM5	3xM5	3xM5	3xM5
	F	5	8	8	8
	L	92	100	110	121
	M	55	59	64	68
	N	21	23	25	28
	P	2	2	3	3
	Q	14	16	18	22
	R	20	22	24	26.8
	S	12	14	16	18
	T	6	6	6	6
U	12	14	16	20	
W	6	7	8	8	
Weight [lbs / kg]		1.5 / 0.7	2.2 / 1.0	3.7 / 1.7	8.8 / 4.0

[ Note 1 : Model 1.2 has single field bearing ]

[ 1" = 25.4mm ]

# HC: TYPICAL INSTALLATION

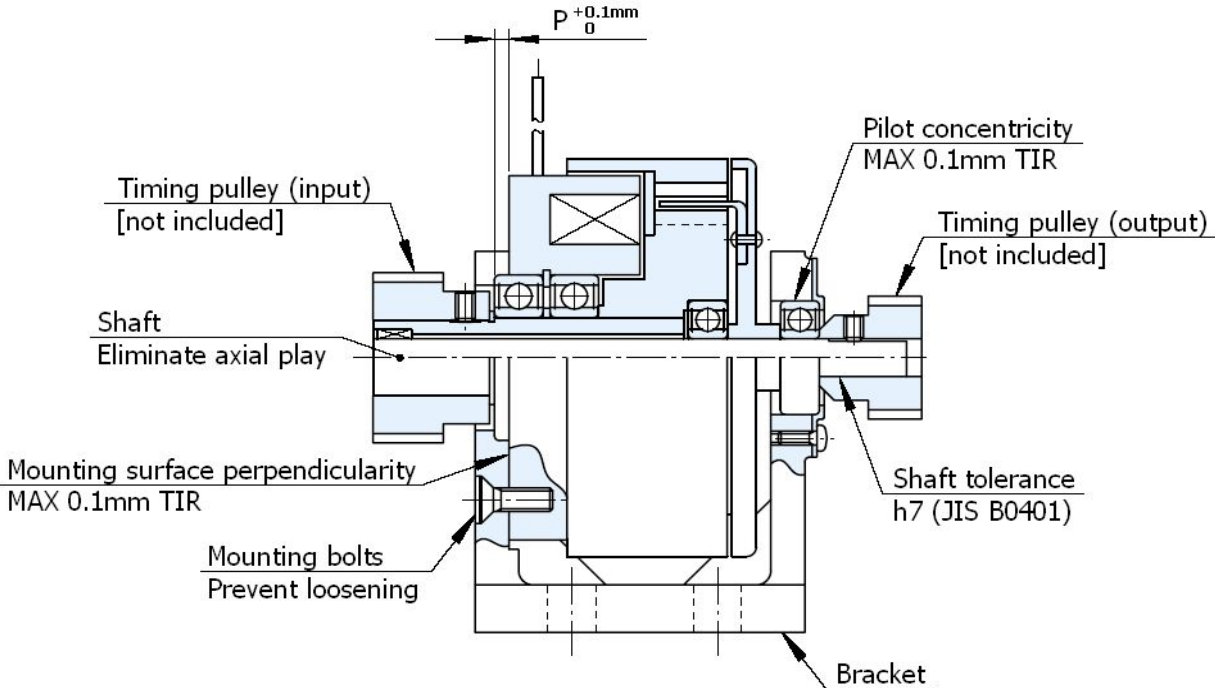

# HC: TORQUE CHARACTERISTIC

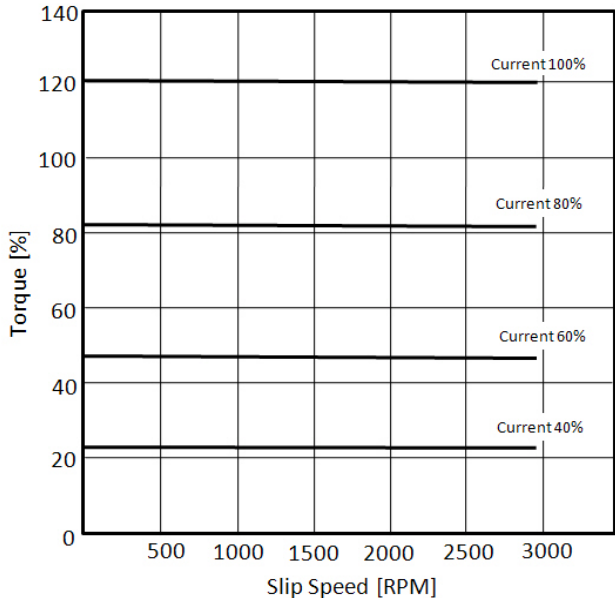
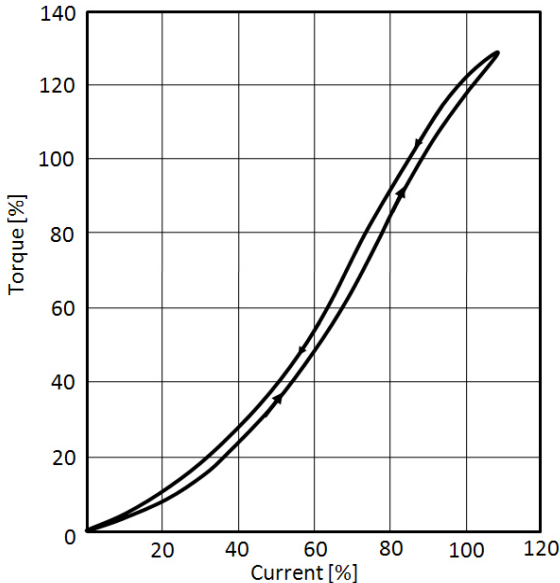

# **OGURA**

## **ELECTROMAGNETIC CLUTCHES & BRAKES**

### **Ogura Warranty:**

Products are warranted against defects in material and workmanship for a period of 12 months from date of shipment, when applied in proper applications within specified ratings. This warranty covers repair or replacement, F.O.B Somerset, New Jersey.

There is no further warranty or implied representation as to any product. The company shall not be liable for any consequential damage caused by improper application or installation of its product.

**Superior Technology in Motion Control**

