

Name: _____
 Date: _____
 Track: _____

Track conditions

Size: Open Med. Tight
 Traction: High Med. Low
 Surface: Smooth Med. Bumpy

Result

Race time / Lap: _____
 Best lap (1Lap): _____

Front suspension

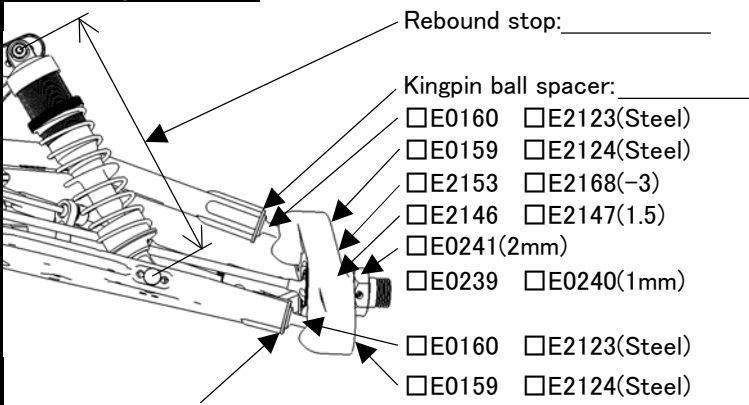

Ride height: _____
 Toe angle: _____
 Lower arm plate: _____
 E2161A,B
 E2166(CFRP)
 Anti roll bar: _____
 Upper arm spacer: _____

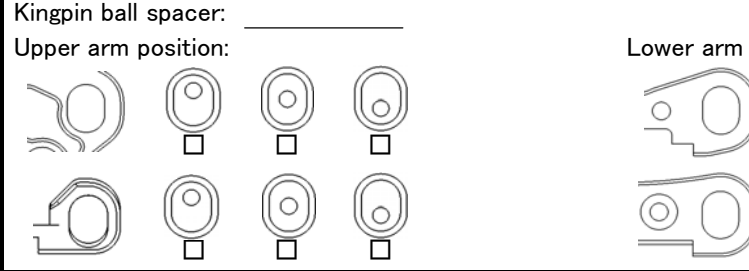

Front shocks

Piston: _____ Oil: _____
 Spring: _____
 Shock position: _____

 Pivot ball position: _____
 Front Rear

Steering ackerman

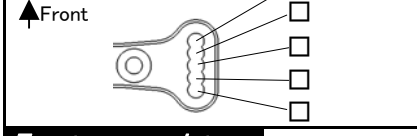

Front upper plate

E2148D E2158(CFRP)

Servo saver arm

E2301A E2310(Aluminum)

Rear suspension

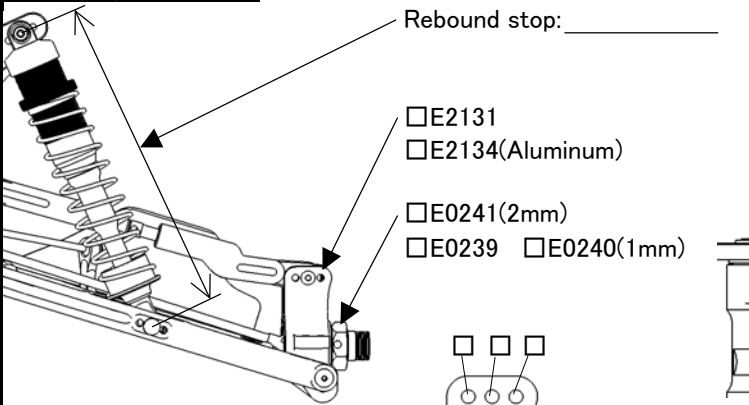

Ride height: _____
 Camber angle: _____
 Lower arm plate: _____
 E2162A,B
 E2167(CFRP)
 Anti roll bar: _____
 Lower arm spacer: _____
 Upright spacer: _____

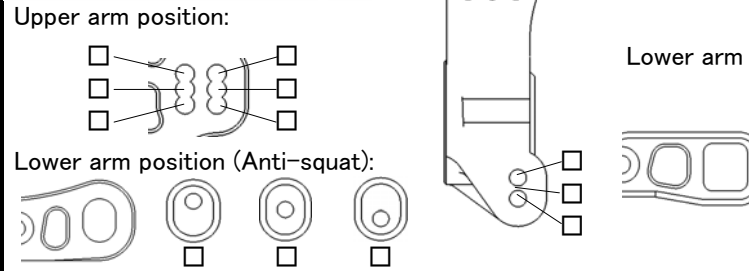

Rear shocks

Piston: _____ Oil: _____
 Spring: _____
 Shock position: _____

 Pivot ball position: _____
 Front Rear

Center shaft

E2215,E2216(CVD) E2230,E2231

Tension rod

Front: E2107A(Long) E2107B(Short)
 Rear: E2148C E0803(Rubber)

Weight

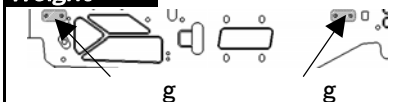

Engine

Type: _____ Plug: _____ Reducer: _____
 Muffler: _____ Fuel: _____ Gasket: _____
 Engine mount: E0701(Standard) E2713(One Piece)

Diff. gear

Oil _____
 Front: _____
 Rear: _____
 Center: 44T 46T
 47T 48T

Tires

	Front	Rear
Type:	_____	_____
Compound:	_____	_____
Inserts:	_____	_____
Wheel:	_____	_____

Clutch

	Clutch bell:	Oil					
		<input type="checkbox"/> 13T	<input type="checkbox"/> 14T	ϕ 0.9	ϕ 0.95	ϕ 1.0	ϕ 1.05
A	<input type="checkbox"/> C0754 <input type="checkbox"/> E0704 <input type="checkbox"/> E0710						
B	<input type="checkbox"/> C0754 <input type="checkbox"/> E0704 <input type="checkbox"/> E0710						
C	<input type="checkbox"/> C0754 <input type="checkbox"/> E0704 <input type="checkbox"/> E0710						

Body/Wing

Body: _____
 Wing: _____
 Wing stay: E2422A E2428A(+15)
 Wing position: _____

 Front

Comments

.....

