

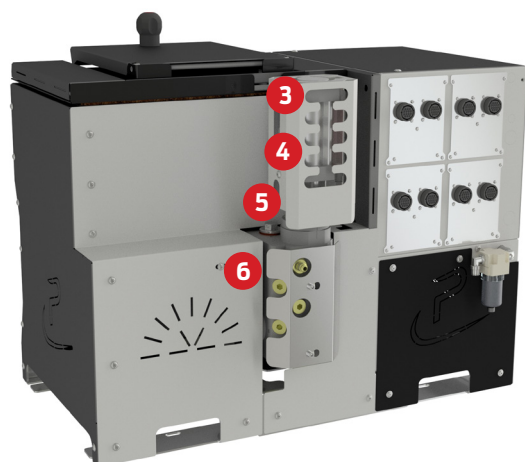

The new P20 EASY TOUCH Series applicators for hot-melt adhesives with pneumatic pump are significantly innovative in terms of simplicity of use, productive flexibility, maintenance operations and costs, speed of installation, easy programming, high safety standards, exceptional reliability and total integration with any existing assembly line. They represent a quality solution for application of thermoplastic hot-melt adhesives in several sectors. The EASY TOUCH systems are equipped with a new microprocessor with 7" LCD Touch Screen colour display, through which, with a single graphic interface showing all sections of the system (tank, manifold, hoses and guns). The operator is supported in everyday activities like managing and setting temperatures, pump control, setting machine parameters and glue sections, and integration and communication with any external units, allowing for immediate use of the system even by non-specialized personnel, without any problems involving codes or foreign languages to be interpreted. The EASY TOUCH melters have a new melting tank, entirely redesigned, to distribute the heat more evenly over the entire surface, thus obtaining a more precise and effective melt, with significant energy savings. The particularly well-finished design makes the system appreciable even in aesthetic terms. Every part of the applicator can be inspected easily by opening the practical body system. EASY TOUCH Applicators - customizable in several configurations and capable of satisfying all gluing needs - allow the operator to work in complete safety and to significantly optimize application times without wasting time uselessly.

EASY TOUCH P20



1. NEW MICROPROCESSOR WITH 7" TOUCH SCREEN DISPLAY

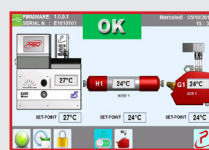

The following are some of the main functions of the new user interface: sequential channel heating, machine ready and pump start signals, absolute maximum temperature protection system, Economy Dual Mode, Weekly Program with Daily ECO function, colour status button with real time diagnostics and Screen Saver function, hose-gun coupling thermal regulation deactivation, LOG file for system register, Life Hours/Work Hours/Pump Cycles counter, machine parameters and Firmware updates uploaded and downloaded through a USB port, customizable system section and glue program names, and parameter Copy/Paste function.

2. NEW MELTING TANK WITH 20 L CAPACITY



The new tank was entirely redesigned to ensure perfect efficiency in terms of melting evenness and capacity. The large loading inlet open on 3 sides makes filling easier, optimising cleaning and maintenance operations. The shaped resistance positioned on the bottom of the tank distributes heat evenly and improves thermal efficiency throughout the system, thus resulting in energy savings. The tank bottom slope (about 20°), and the melting fins - positioned parallel to the upper edge of the tank in a fan-shaped configuration - were designed specifically to melt the glue more effectively, so it can slide directly towards the pump drawing spot. The rapid discharge - located at a lower level and on the opposite side compared to the drawing spot - facilitates the collection of any impurities in the adhesive or burnt glue residue, conveying them to a single sump and preventing them from being sucked up by the pump and causing a machine shutdown, also allowing for quick cleaning operations either for maintenance purposes or to replace the adhesive.

3. ELECTROMAGNETIC INVERSION SYSTEM



Guarantees absolute precision in the pneumatic pump inversion cycle, thus assuring that the adhesive flow rate is always constant and balanced, significantly reducing the lack of adhesive during the inversion cycle. The use of reed-switch type proximity sensors (protected and sealed inside the electronic cylinder, and therefore never in contact with the outside environment and not subject to wear) increases the reliability of life cycles, reducing machine shut-downs for malfunctions or maintenance, giving the system mechanical solidity, in addition to resistance to environmental conditions and to electrical and electromagnetic disturbances.

4. HIGH PRECISION PNEUMATIC PUMP



The 14:1 dual-effect piston pump is ideal for melting and applying adhesives and thermoplastic materials with a viscosity of up to 30,000 Cps. Treated with a hard oxide coating, it is easy to extract in case of maintenance or replacement operations. The bottom of the pump is inspectable in order to check the conditions of the suction sphere.

5. GLUE FILTER



Easy to access and replace, it guarantees excellent quality of application, preventing impurities in the adhesive from clogging the nozzles. There is a wide range of available models (with single or multi-layer filtering micro-mesh, and different pitches starting from 200 micron) depending on the type of adhesive used.

6. AUTOMATIC PRESSURE RELIEF VALVE



A standard part, it guarantees maximum safety during operation by automatically discharging residual pressure in case of emergency or system shut-down.



EASY TOUCH P20

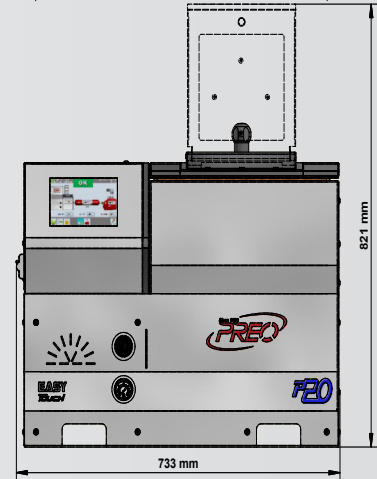
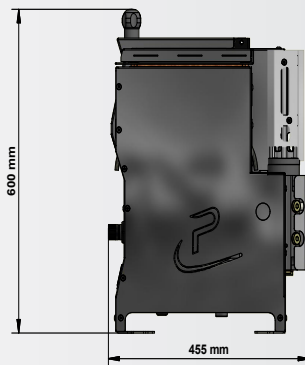
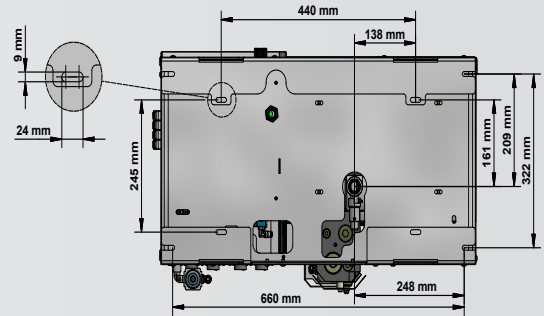

GENERAL SPECIFICATIONS

ADHESIVE TYPOLOGY AND VISCOSITY	hot-melt up to 30.000 Cps
OPERATING TEMPERATURE	50°C±210°C (120°F±410°F) standard version - 50°C±230°C (120°F±450°F) HT high temperature version
HOSE/GUN CONNECTIONS	2, 4, 6, 8 (fitting thread 1/2"x20 UNF)
TANK CAPACITY	20 Kg (44 lb)
MELTING RATE	21 kg/h (depending on used adhesive typology)
WEIGHT (EMPTY)	90 Kg (198 lb)
MACHINE DIMENSIONS (L X H X W MM)	733 x 821 x 455 mm
TANK OPENING DIMENSIONS (MM)	180 x 184 mm
TANK	internally coated with PTFE scratch-resistant non-stick treatment, heated fins and quick drain valve
MANIFOLD	coated with hard oxidation treatment and glue filter integrated
WARM-UP TIME	35'±40' starting from ambient temperature (0°C±45°C (32°F±113°F))
FASTENING	slots for M8 screw

ELECTRICAL SPECIFICATIONS

VOLTAGE	1/N/PE AC 230 V ± 10% 50/60 Hz, 3/N/PE AC 400V ± 10% 50/60 Hz
POWER CONSUMPTION	4,2 kW (18 A) without hoses and guns
MAXIMUM POWER PER CHANNEL	1,0 kW

MICROPROCESSOR SPECIFICATIONS

TEMPERATURE CONTROL	PT100 ± 0, 5°C (1°F) - Ni120 e NTC (on request)
MICROPROCESSOR	7" Resistive Touch Screen - LCD TFT LED lighted colour display - resolution 800x480 pixel (USB, Ethernet, and Windows CE software)
FUNCTIONS	Economy, Clock, Weekly Program, Maximum Temperature Alarm, Sequential Heating Zones
SAFETY	by-pass safety valve, over-temperature automatic protection, emergency stop input alarm, glue pressure release, "real time" diagnostics
OPTIONS	level sensor, quick pressure release valve and flow regulation, integrated glue pattern control, automatic filling system

PNEUMATIC PUMP SPECIFICATIONS

PUMP TYPE	double acting pneumatic piston pump ratio 14:1
REVERSING SYSTEM	electro-magnetic with end stroke sensors
MAXIMUM PUMP RATE	35 kg/h (depending on used adhesive typology)
WORKING PRESSURE	0,3±5,0 bar
MAXIMUM WORKING PRESSURE	55 bar