



ERALP[®]

BOILER AND ENERGY TECHNOLOGIES



www.eralpkazan.com



HAKKIMIZDA | COMPANY PROFILE

Türkiye'nin en verimli kazanlarını üreten Eralp Makine Kazan uzmanlaşmış kadrosu ile 1992 yılından bu yana Bursa Mustafakemalpaşa fabrikasında 10.000 m² kapalı olmak üzere 55.000 m² alanda, 25 yıllık tecrübesi ile Buhar Kazanları, Atık Isı kazanları, Su Borulu Kazanlar, Kızgınyâğ Kazanları, Yüksek Frekans Kanatlı Boru, Basınçlı Ekipmanlar üretimi ve satışı hakkında hizmet vermektedir.

Sahip olduğumuz **ISO 9001, EN 3834-2, AD 2000 HPO, Gost ve ASME U ve S** sertifikalarımız ile yerli ve yabancı müşterilerimizin hizmetinizdeyiz.

We have been giving service to our customer with our specialized staff in the 10.000 m² closed, totally 55.000 m² area about Industrial Boiler, Waste Heat Recovery Boiler, Water Tube Boiler, Thermail Oil Heater, High Frequency Welded fintube, Heat exchanger, Pressure Equipment etc. since 1992 in Bursa/Turkey.

*With our **ISO 9001, EN 3834-2, AD 2000 HPO, Gost ve ASME U and S** stamp, we are giving a service to our customer all over the world.*



ISO 9001 : 2015

AD MERKBLATTER HPO
EN ISO 3834-2





Water Tube Boiler

Su Borulu Buhar Kazanı

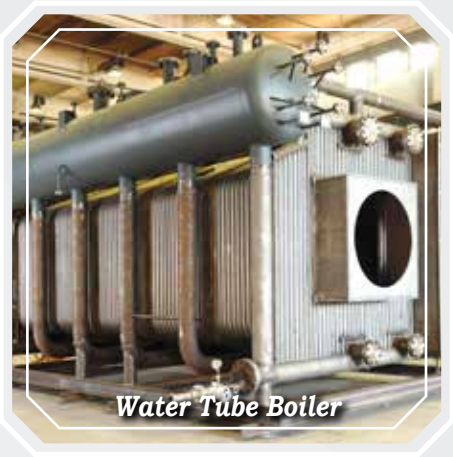

Water Tube Boiler

Su Borulu Buhar Kazanı



Scotch Type Steam Boiler

Skoç Tipi Buhar Kazanı



Waste Heat Recovery Boiler

Atık Isı Kazanı



Autoclaves

Otoklav



Thermal Oil Heater

Kızgın Yağ Kazanı

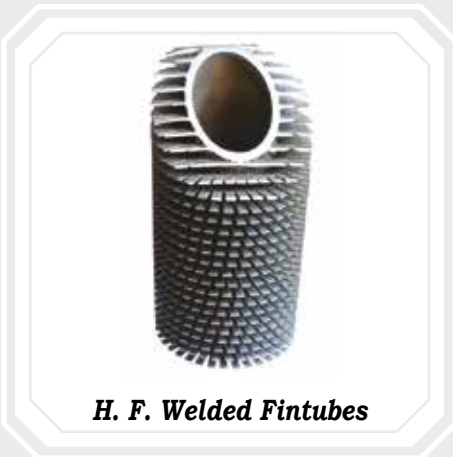

H. F. Welded Fintubes

Yüksek Frekans Kaynaklı Kanatlı Boru



Bundle Manufacturing

Bundle Üretimi



- * BUHAR KAZANLARI | STEAM BOILER
 - Skoç Tipi | Scotch Type
 - Su Borulu | Water Tube Type
- * ATIK ISI KAZANLARI | WASTE HEAT RECOVERY BOILER
 - Skoç Tipi | Shell Tube Boiler
 - Su Borulu | Water Tube Type
- * KIZGIN YAĞ KAZANLARI | THERMAL OIL HEATER
- * KATI YAKITLI KAZANLAR | BIOMASS BOILER
- * OTOKLAVLAR | AUTOCLAVES
- * BUHAR AKÜLERİ | STEAM ACUMULATOR
- * YÜKSEK FREKANS KAYNAKLI KANATLI BORU
| HIGH FREQUENCY WELDED FINTUBE
- * BUNDLE ÜRETİMİ | BUNDLE MANUFACTURING
- * EKONOMİZERLER | ECONOMIZERS
- * DEGAZÖRLER | DEAERATOR
- * REAKTÖRLER | REACTORS
- * EŞANJÖRLER | HEAT EXCHANGER

HİZMETLERİMİZ | OUR SERVICES

- * ONDÜLE KÜLHAN ÜRETİMİ | CORRUGATED FURNACE
- * PANEL YAPIMI | PANEL MANUFACTURING
- * LABORATUVAR HİZMETLERİ | LABORATUARY SERVICES



Buhar kazanları, işletmelerde proseslere gerekli buharı elde etmek için kullanılan, küçük su ve yüksek buhar hacmine sahip, yüksek kalitede buhar üreten cihazlardır.

Külhan türlerine göre; Düz külhanlı ve sıcak basım ondüle külhanlı, Yakıt türlerine göre; Katı, Sıvı ve Gaz yakıtlı türleri mevcuttur.

Eralp olarak Sıcak Basım ondüle külhanlı ve her yakıt ile çalışabilen buhar kazanı tasarımı, üretimi ve montajını yapmaktayız.

İşletme basıncına bağlı olarak kazan verimi %91'e kadar çıkmaktadır. Tarafsız kontrol kurumu olan ISKAV vakfı testlerinde; firmamızın üretmiş olduğu çift ekonomizerli sistemde (1.si besi suyu ve 2. kullanım suyu ekonomizer ile) toplam sistem verimi **%98,4** elde edilmiştir.

Steam boiler which has small water and high steam volume generates required high quality steam for processes.

Classification of furnace according to standard is plain and corrugated type. According to boiler fuel types, there are solid, liquid and gas fired boiler that we are able to manufacture.

As Eralp, we manufacture our Boiler with hot-formed corrugated furnace and solid, liquid fuel and gas fired in CE mark.

*According to pressure of boiler, efficiency increase up to %91. Eralp manufactured the highest efficient boiler (totally efficiency=**%98,4**) with two economisers which efficiency tested and approved by Notify Body.*



BUHAR KAZANI | SHELL BOILER

Firmamız kazanlarını; en yeni teknolojiye sahip ve yakıtın iyi yakılmasını sağlayan, daha çabuk rejime giren, ideal ısı geçişinin en iyi sağlandığı ve kolay temizlenme gibi birçok avantajları olan Yandan külhanlı olarak üretmektedir.

Külhanlarımız **900°C**'de sıcak ondüle olarak üretilmektedir. Kazan yanma odası yükünü **1,2 MW/M³**' den daha düşük tutularak bu sayede ideal bir yanma sağlanmakta ve azot oksit (NOx) emisyonu azaltılmaktadır.

Kazan çıkışında, duman gazlarının ısısından daha fazla yararlanarak verimi artırmak için ekonomizer ilave edilir. Ekonomizer ile besi suyunun ön ısıtılması, kullanım suyu ve yanma havasının ısıtılması mümkündür. Atık enerjiden faydalanılarak kazan verimi **%5-8** daha artırılabilir.

Thanks to large contact surface of water with smoke pipes, high operational safety and longer boiler life are guaranteed. The small water volume provides a better inside circulation and safe heat transfer with faster steam generation time.

*Increased strength and flexibility with corrugated furnace that is manufacturing by Eralp in **900°C** degrees. In 3-pass Shell boiler design, the heat load of furnace is less than **1,2 MW/m**. The result of this design is an ideal combustion with less NOx emissions, thus it causes lower fuel consumption.*

*Further gains in efficiency can be obtained by using economizer for feeding water by preheating and air-heater for combustion air heating. The energy of flue gas can be recovered and the efficiency of boiler system is increased **5-8%**.*

**Verim
Efficiency
%98.4**

Bursa Aroma Tesisleri



"Bursa Aroma tesislerinde kurmuş olduğumuz 10 ton/h, 10 bar kapasiteli buhar santrali max. kapasitede test sonucu; verim %98.4 tür."



"Bursa Aroma 10 ton/h, 10 bar steam boiler. Total efficiency is %98.4."

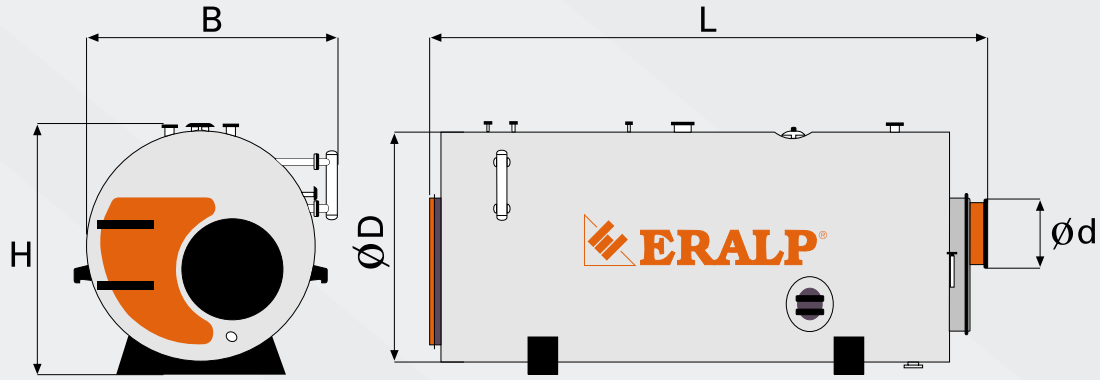

BUHAR KAZANI BOYUTLAR ve TEKNİK BİLGİLER (Steam Boiler Dimensions and Technical Properties)																		
TİP :SBK		Anma Isıtma Yüzeyi (m ²)		25	30	35	40	45	50	60	70	80	90	100	110	125	135	155
KAPASİTE (CAPACITY)	BUHAR (STEAM)	Nominal (Nominal)	kg/h	1100	1350	1600	1800	2000	2250	2700	3000	3600	4000	4500	5000	5600	6000	7000
	GÜÇ (POWER)	Nominal (Nominal)	Mcal/h	615	755	896	1008	1120	1255	1512	1680	2020	2240	2520	2800	2800	3360	3920
			kW	715	880	1040	1170	1300	1460	1760	1950	2350	2600	2930	3255	3255	3900	4560
Kazan Karşı Basıncı			mmSS	55	55	55	55	60	60	60	65	65	70	80	85	85	90	90
Su Hacmi (Water Volume)			m ³	1,9	2	3	3,6	4,5	4,5	5,5	6	6,5	7,1	9,1	10	10,6	11,8	12,5
Taşıma Ağırlığı (Transport Weight)			ton	3,7	4	5	6	7	7,2	8,2	9	10	11	12,2	13,5	14,8	16	17
Ölçüler (Dimensions)		B	mm	1950	2000	2000	2000	2000	2050	2140	2200	2400	2500	2570	2650	2700	2750	2770
		H	mm	2000	2150	2150	2150	2150	2180	2280	2500	2600	2650	2690	2650	2750	2850	2910
		L	mm	3000	3660	3800	3850	3900	4000	3760	4000	4500	4900	5000	5600	5750	5900	6080
		D	mm	1800	1900	1950	1950	1950	2000	2100	2150	2150	2250	2400	2450	2500	2600	2750
Duman Gazı Çıkış Ölçüleri (Smoke Outlet Dimensions)		d	mm	300	300	320	320	330	340	350	380	400	450	500	530	540	600	650

10 bar doymuş buhar ve 102 °C 'de degazörden besleme suyu sıcaklığına göredir. EN 12953 standartına uygun besi suyu ve %12 hava fazlalığı ile çalışan brülör kullanıldığında. Kataloğun hazırlanması sırasında tüm özen gösterilmiş fakat değerler uygulama projesi sonunda kesinleşir. Katalog değerleri üzerinde her türlü değişiklik yapma hakkımız saklıdır.

For 10 bar saturated steam and 102 °C degaser feed water temperature. With feed water acc. to EN 12953 standard recommendations and maximum 12% excess air firing conditions. Our boilers are manufactured acc.to EN 12953 standards recommendations. Every attention has been taken in the preparation of this catalogue. Dimensions and weights should be confirmed by final drawings and the company reserves the right to amend any part at its discretion.



BUHAR KAZANI | SHELL BOILER

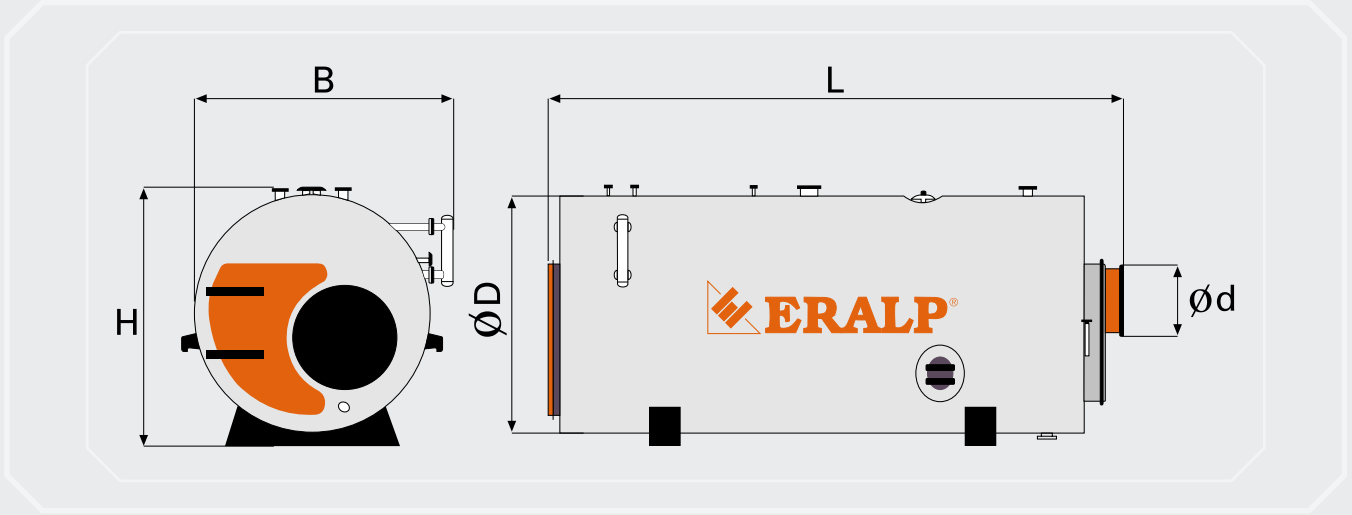

BUHAR KAZANI BOYUTLAR ve TEKNİK BİLGİLER (Steam Boiler Dimensions and Technical Properties)

TİP :SBK		Anma Isıtma Yüzeyi (m ²)	180	200	235	250	275	300	335	350	400	450	480	500	550	600	660	
KAPASİTE (CAPACITY)	BUHAR (STEAM)	Nominal (Nominal)	kg/h	8000	9000	10000	11000	12000	13500	15000	16000	18000	20000	22000	23000	25000	27000	30000
	GÜÇ (POWER)	Nominal (Nominal)	Mcal/h	4480	5040	5600	6160	6720	7560	8400	8960	10080	11200	12320	12280	14000	15120	16800
kW			5210	5860	6510	7160	7810	8790	9765	10415	11720	13020	14325	14975	16280	17580	19535	
Kazan Karşı Basıncı			mmSS	95	100	105	105	110	110	115	115	120	125	125	130	140	145	145
Su Hacmi (Water Volume)			m ³	13	13,3	17,1	17,6	18,9	20	22,5	24,5	26,5	28,5	29,4	31	34	35,5	38,5
Taşıma Ağırlığı (Transport Weight)			ton	18,5	19,5	21,5	22,5	23,5	24,5	29	32	35,5	38,5	40	42	49	55	59
Ölçüler (Dimensions)		B	mm	3000	3070	3130	3200	3290	3350	3500	3630	3800	4000	4100	4200	4350	4600	4800
		H	mm	3260	3300	3360	3400	3430	3500	3650	3700	3850	3900	4500	4750	5500	5600	5700
		L	mm	5900	6450	6500	6630	6680	6850	6900	6920	6950	7000	7400	7500	7500	7200	7300
		D	mm	2950	2950	3050	3100	3200	3300	3400	3500	3500	3700	3750	3800	4300	4350	4500
Duman Gazı Çıkış Ölçüleri (Smoke Outlet Dimensions)		d	mm	700	750	800	800	850	860	900	960	1000	1050	1100	1100	1150	1200	1250



Su borulu kazanlar; su sirkülasyonunun boru içinde olduğu, Yüksek basınç ve yüksek buhar ihtiyaçlarını karşılamak için kullanılırlar.

Kazan çevresi boru-kanat-boru şeklindeki membran duvarlar ile kaplı olup, kazan dizaynı ve üretimi ASME ve EN 12952 ye göre yapılmaktadır.

Eralp olarak Alman **ERK EckRohr Kessel GmbH** firmasının lisansı ile kazanlarımızı Katı, Sıvı ve gaz yakıtlı olarak üretmekteyiz.

Su borulu kazanlar Skoç tip kazanlara göre daha güvenli olmakla birlikte yatırım maliyeti daha pahalı ve çalıştırma esnasında daha iyi su şartlandırması gereklidir.

Water tube boiler which is water circulation in the tube is manufactured for big capacity steam requirement and high operating pressure.

Combustion chamber is covered with tube-fin-tube(membrane) panels. Design and manufacturing is made according to ASME and EN 12952 standard.

*As Eralp, by using **ERK EckRohr Kessel GmbH** licences, we manufacture our boiler as solid fuel, liquid fuel and gas.*

Water tube boiler is safer than Shell tube boiler. But, it requires higher investment cost and good water treatment during operation.



SU BORULU KAZAN | CORNER TYPE WATER TUBE BOILER

Eralp olarak su borulu kazanlarımızı müşteri istekleri olan; verimlilik, basınç, buhar sıcaklığı, emisyon ve yakıt cinsine göre üretmekteyiz. Bu nedenle bu tür kazanlarda tamamen müşteriye özel üretim yapmaktayız.

Bu tip kazanlar sayesinde küçük yerlere daha çok buhar ihtiyacını karşılayacak kazanlar üretmekteyiz.

As Eralp, we manufacture our water tube boiler by considering customer requirements that are efficiency, pressure, superheated steam temperature, fuel types, emission etc. We have flexible manufacturing. Therefore, we can manufacture both horizontal and vertical boiler.

As Eralp, we manufacture big steam capacity boiler in small area thanks to water tube boiler.

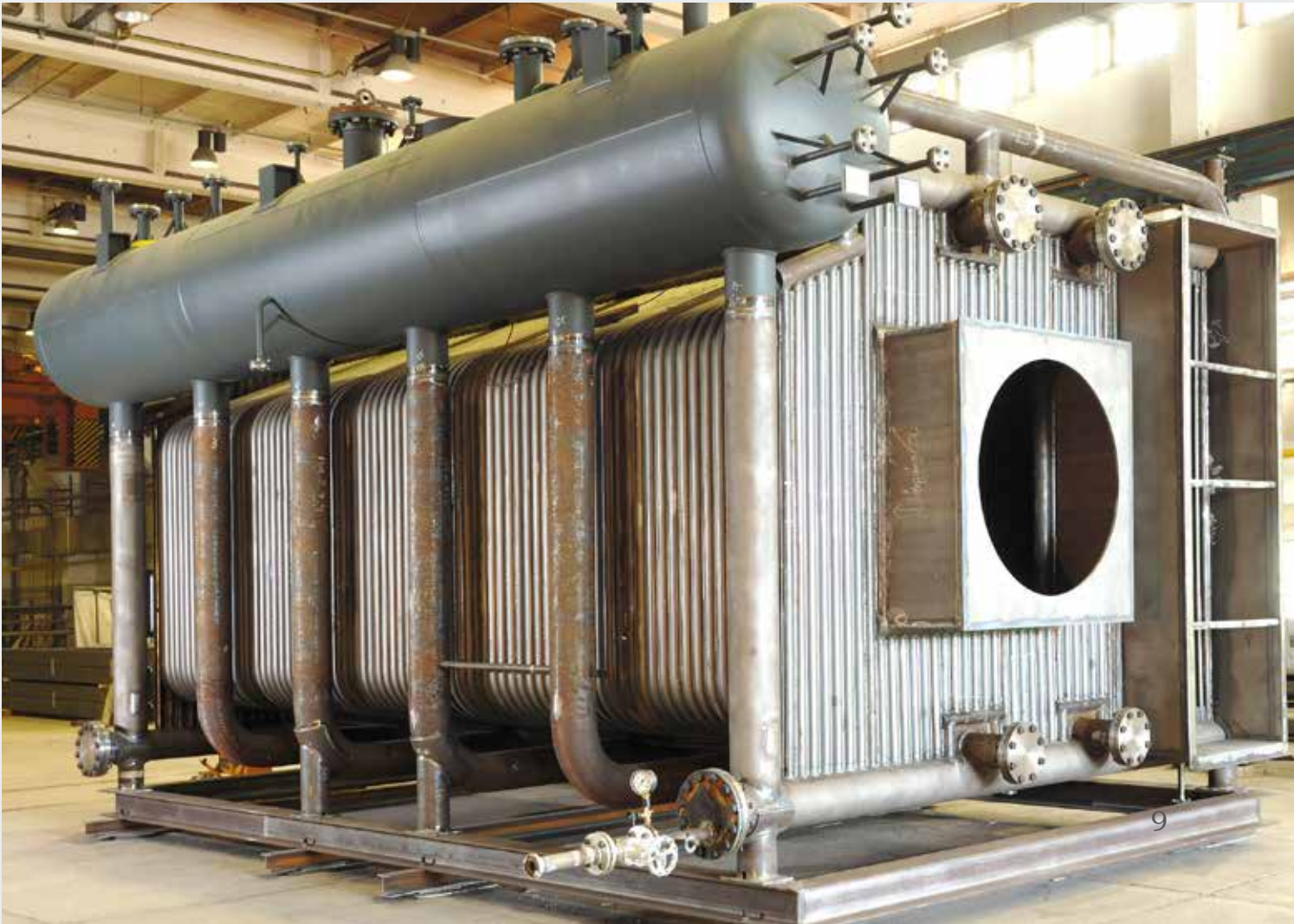

ALEV BORULU ATIK ISI KAZANI | SHELL TUBE WASTE HEAT BOILER



Isı geri dönüşümü için tasarlanan ve üretilen Atık Isı Kazanları ısıtılacak akışkana ve prosese göre birçok alanda kullanılmaktadır.

Kombine Çevrim Santrallerinde(KÇS – Combine Cycle Power Plant - CCPP) türbin arkası atık gazlardan tekrar kızgın buhar üreterek tekrar buhar türbininde elektrik enerjisine dönüştürmek için kullanılan bu kazanlar HRSG(Heat Recovery Steam Generator) olarak adlandırılır.

Gazın fiziksel özellikleri, içeriği, debisi ve proses şartlarına göre alaşımli, yüksek alaşımli ve paslanmaz malzemeden üretilen atık ısı kazanları su borulu veya alev-duman borulu olarak tasarlanıp üretilirler.

Eralp olarak müşteri taleplerine göre alev duman borulu ve su borulu tip atık ısı kazanı yapmaktayız.

Waste Heat Boilers(WHBs)are designed to recover the waste heat at the downstreams of gas turbines, gas motors, process furnaces,etc.

WHBs are referred to as Heat Recovery Steam Generators(HRSGs) in Combine Cycle Power Plants(CCPPs) which produce superheated steam by using turbine exhaust gas, to generate electricity through steam turbine generator (STG).

WHBs are designed and manufactured as water-tube and Shell tube boilers that are made of alloyed, high alloyed and/or stainless steel materials according to flue gas physical features, contents, flow and process conditions.

We design and manufacture our Heat Recovery Boiler according to our costumer requirements.



ATIK ISI KAZANI | WASTE HEAT BOILER

SU BORULU ATIK ISI KAZANI | WATER TUBE TYPE WASTE HEAT BOILER



Ayrıca daha düşük kapasiteli türbin, gaz ve sıvı yakıtlı motorların arkasından elde edilen atık gazlardan (Kojenerasyon) proses ihtiyacı kızgın buhar, buhar, kızgın ve sıcak su elde eden kazanlarda uygulanmaktadır.

Çimento, çelik, ısıl işlem ve boya fırınları vb. endüstriyel tesislerden elde edilen atık gazlardan da işletme ihtiyacına yönelik kazanlar üretilmektedir.

Eralp Kazan olarak yüksek kapasiteli ya da düşük kapasiteli fark etmeksizin imal etmiş olduğumuz su borulu atık ısı kazanlarında gazındaki ısıyı aktarmak için kullanılan ısıtma yüzeyini, **Türkiye'nin ilk ve tek üreticisi olduğumuz "Yüksek Frekans Kaynaklı Kanatlı Boru"** ile yapmaktayız.

Beside, WHBs are widely used to produce superheated steam, saturated steam, superheated water and hot water according to process requirements by using exhaust flue gases from high and low capacity gas turbines, gas and oil fired engines.

We are manufacture WHBS to recover waste heat from rotary kilns, glass furnaces, steel and heat treatment furnaces, paint booths, etc.

*Eralp Boiler is manufacturing water tube waste heat boilers by using **"High Frequency Welded Finned Tube"** as heat transfer surfaces in order to transfer heat for process fluid, and is the **first and only one manufacturer in Turkey.***



300-320°C'nin üzerindeki sıcaklıklarda ısı enerjisi ihtiyacını etkin ve güvenli bir biçimde karşılamak için kızgın yağ kazanları kullanılmaktadır. Kızgın yağ sistemleri, subuhar gibi ısı taşıyıcı akışkanların ulaşamayacağı yüksek sıcaklıklara, atmosferik basınçta ulaşılması sağlanır.

Eralp olarak CE sertifikalı Sıvı yakıt, Biomass, Gaz ve Katı yakıtla çalışan kızgıny yağ kazanları üretmekteyiz.

Sistem verimini kazan arkasına ilave edilecek ekonomizer ile arttırmaktayız.

Üretimimizde standart olarak Avrupa menşeli, EN 10216-2 normuna uygun çelik çekme borular kullanılıp, Otomasyon sistemimizde sayesinde de sistemin emniyetli bir şekilde çalışmasını sağlamaktayız.

Kızgıny yağ kazanları başlıca Tekstil, Kimya, Kauçuk ve Ağaç Sanayinde kullanılırlar.

*Thermal oil boilers are used for meeting thermal energy requirement safely and effectively over **300-320°C** degree. Thermal oil systems provide to reach higher temperature that heat transfer liquid cannot reach in the atmospheric pressure.*

We manufacture our Thermal Oil heater with Solid, Liquid fuel and gas fired with CE certification.

System efficiency is increased by adding economizers behind the boiler.

Also, we manufacture our boiler with European Union trade seamless tube which is manufacturing according to EN 10216-2. We provide safer boiler to our customers with our automation system.

Thermal oil heaters are generally used in Textile, Chemical, Rubber and Wood industry.



KIZGIN YAĞ KAZANI | THERMAL OIL HEATER

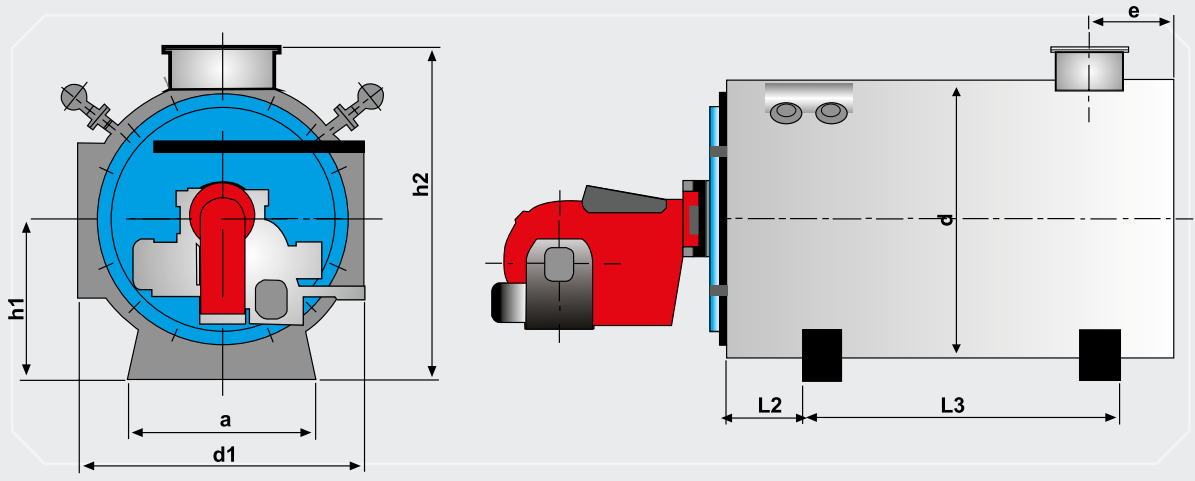

Kızgın Yağ Kazanı Boyutları ve Teknik Bilgiler (Thermal Oil Heater and Technical Properties)

Tip (Type)	Kapasite (Capacity)		a	d	d ₁	d ₂	d ₃	e	h ₁	h ₂	L ₁	L ₂	L ₃
KYK	kW	Kcal/h	mm	mm	mm	mm	mm	mm	mm	mm	mm	mm	mm
400	465	400.000	1.000	1.150	300			350	700	1.400	1.800	300	1.000
600	700	600.000	1.300	1.400	350			400	750	1.700	2.150	300	1.500
800	930	800.000	1.400	1.600	400			400	850	1.850	2.350	350	1.650
1000	1160	1.000.000	1.400	1.600	500			450	950	1.850	2.650	400	1.850
1250	1.450	1.250.000	1.500	1.700	500			450	1000	2.000	2.950	450	2.000
1500	1.750	1.500.000	1.800	1.980	500			450	1.150	2.200	3.250	450	2.350
2000	2.325	2.000.000	1.850	2.075	500			450	1.200	2.400	4.000	500	3.000
2500	2.900	2.500.000	2.000	2.300		650	350	300	1.300	2.570	4.500	400	3.500
3000	3.500	3.000.000	2.100	2.400		800	400	325	1.350	2.665	5.100	600	4.250
4000	4.650	4.000.000	2.150	2.450		800	400	325	1.400	2.720	6.150	650	5.000
5000	5.820	5.000.000	2.450	2.800		900	550	400	1.600	3.045	7.100	650	5.750
6000	7.000	6.000.000	2.650	3.000		1.000	550	400	1.640	3.295	7.250	700	5.800
7000	8.140	7.000.000	2.900	3.300		1.100	700	475	1.760	3.535	8.200	800	6.500
8000	9.300	8.000.000	3.000	3.450		1.200	700	475	1.840	3.695	8.650	800	7.000

Gerçek ölçüler, hesaplamalar sonucunda ortaya çıkar. Tablo sadece genel bilgi amaçlıdır.

Exact dimensions is given after calculation of new design. This table shows only general information.



Genellikle pişirme işleminde kullanılan otoklavlar, dur kalk çalışmalarından dolayı kritik basınçlı ekipmanlar kısmına girmekte ve bu nedenle dizaynı ve üretimi titizlik ve tecrübe gerektirmektedir.

Tecrübeli kadromuz ile 25 yıldır otoklavlarımızı yurt içi ve yurt dışındaki seçkin müşterilerimize üretmenin gururunu yaşamaktayız.

Genel olarak otoklav kullanan endüstriler:
İnşaat,
Kauçuk,
Tekstil,
Otomotiv vb. sayılabilir.

Eralp olarak Otoklavlarımızı müşteri taleplerine göre EN 13445 ve AD 2000 Merkblatt standardına göre CE markalı olarak tasarlayıp, üretmekteyiz.

Because of high frequency of start stop cycle, autoclave manufacturing needs more experience and controls than other pressure parts.

With our expert staff, we have given a service since 1992 about autoclaves.

*Autoclaves are usually used in;
Civil Industry,
Rubber Industry,
Textile Industry etc.*

We design and manufacture our autoclaves according to EN 13445 and AD 2000 Merkblatt standart for our customers.

BUHAR AKÜSÜ | STEAM ACUMULATOR



Buhar aküleri işletmeden çıkan ihtiyaç fazlası veya atık buharların depolanarak gerektiğinde tekrar kullanılması amacıyla imal edilen basınçlı kaplardır. Genellikle prosesten çıkan atık buharın tekrar kazanılması özellikle Gaz Beton tesislerinde kullanılırlar.

Buhar aküsü kullanılarak;

- %25'lere varan enerji tasarrufu sağlanır.
- Katı moleküller buhardan uzaklaştırılır.
- Değişken buhar yüklerine anında cevap verilir.

Aynı anda hem buhar şarjı hem de deşarjı hızlı bir biçimde yapılabilir.

Steam accumulators store redundant or refuse steams to reuse when it is necessary. Generally, it is used for aerated concrete institutions to recover the refused steam that come out of the process.

Using STEAM ACUMULATOR advantages,

- Saving **up to 25%** of energy,
- Cleaning TDS in steam,
- Fast response for unstable steam requirement.

Steam can quickly charge and discharge at the same time.



2009 yılından günümüze **Türkiye'nin "ilk ve tek Yüksek Frekans Kaynaklı Kanatlı"** Boru üreticisi olan firmamız 2 adet üretim hattı ile Ülkemizin ve Dünyanın önde gelen Enerji firmalarına hizmet vermektedir.

Eralp has been "the first and only one manufacturer in Turkey for High Frequency Welded fintube" with 2 line since 2009. And also, Eralp has given a service to domestic and foreign energy companies.

ÜRETİLEBİLİNEN BORU MALZEMELERİ | MANUFACTURED TUBE MATERIALS

MALZEME /Material	MATERIAL NO/ Material No	MALZEME ADI Material Name
KARBON ÇELİKLERİ / CARBON STEEL	1.0305	P 235 GH (SA 106 GrA)
	1.0405	P 265 GH (SA 106 GrB)
DÜŞÜK ALAŞIMLI ÇELİKLER / LOW ALLOWED STEEL	1.5415	16Mo3 (P1)
	1.7335	13CrMo4-5 (P12)
	1.7338	10 CrMo5-5 (P 11)
	1.7380	10CrMo9-10 (P 22)
	1.7386	X12CrMo9-1 (P 9)
	1.4903	X10CrMoVNb 9-1 (P 91)
YÜKSEK ALAŞIMLI PASLANMAZ ÇELİKLER / HIGH ALLOWED STEEL	1.4301	X5CrNi 18 10 (AISI 304)
	1.4306	X2CrNi 19 11 (AISI 304 L)
	1.4401	X5CrNiMo 17 12 2 (AISI 316)
	1.4435	X2CrNiMo 18 14 3 (AISI 316 L)
	1.4571	X6CrNiMoTi 17 12 2 (AISI 316 Ti)



YÜKSEK FREKANS KAYNAKLI KANATLI BORU | HIGH FREQUENCY WELDED FIN TUBE

Müşteri isteklerine göre düz veya tırtıklı tip olmak üzere **22 mt** uzunluğuna kadar yüksek frekans kaynaklı kanatlı boru üretimi yapabilmekteyiz **80.000 m/ay** üretim kapasitemiz ile müşterilerimize hızlı bir çözüm sunmaktayız.

Katalogta olmayan malzeme ve ölçüler için lütfen irtibata geçiniz.

*According to customers demands, we are able to manufacture serrated and solid type HF Fintube up to **22 mt** length. Thanks to **80.000 m/month** capacity, we provide fast services to our customers.*

Please don't hesitate to contact us for material and dimensions which do not list in catalogue.

FİN MALZEMESİ | FIN MATERIAL

Tüm boru ve fin malzemelerinin birbirine kaynağı mümkün olmasına rağmen genel olarak aşağıdaki malzemeler fin malzemesi için kullanılır.

Müşteri isteği veya gereksinimine göre farklı malzeme olması durumunda karşılıklı görüşme, testler ve olanaklar dahilinde farklı fin malzemeleri ile Yüksek Frekans Kaynaklı Spiral Finli Boru üretimi yapılabilir.

- DC 01
- DC 03
- DC 04
- AISI 304 / 316
- AISI 409
- X2CrNi 19 11
- X2CrNiMo 18 14 3 vb.

Although, all fin and tube material can weld each other, usually, following fin materials use as fin material.

We are able to manufacture high frequency welded spiral finning tubes with for customer's different material combination. After all approved tests, we start manufacture fintubes.

- DC 01
- DC 03
- DC 04
- AISI 304 / 316
- AISI 409
- X2CrNi 19 11
- X2CrNiMo 18 14 3 etc.

FİN KALINLIKLARI | FIN THICKNESS

Üretimini yaptığımız Yüksek Frekans Kaynaklı Finli Borularda; **0,8 mm - 2 mm** kalınlıktaki Fin malzemesini Boruya kaynatabilmekteyiz.

0,8 mm kalınlıktan daha düşük kalınlıktaki malzemeleri kaynatmak mümkündür. Fakat teknik nedenlerden dolayı tavsiye edilmemektedir.

*We can weld fin material thickness between **0,8 mm - 2 mm** for high frequency welded spiral finning tubes.*

*It is possible to weld fin thickness less than **0,8 mm** but it is not recommended.*

FİN HATVESİ | FIN PITCH

Boru kalınlığı ve yapılan termodinamik hesaplamalar sonucunda tespit edilen hatve sayısını: **3,5-20 mm** arasında yapabilmekteyiz.

*Pitch distance is determined according to pipe diameter and thermodynamic calculation. We are able to manufacture fintubes pitch in the range of **3,5 - 20 mm**.*

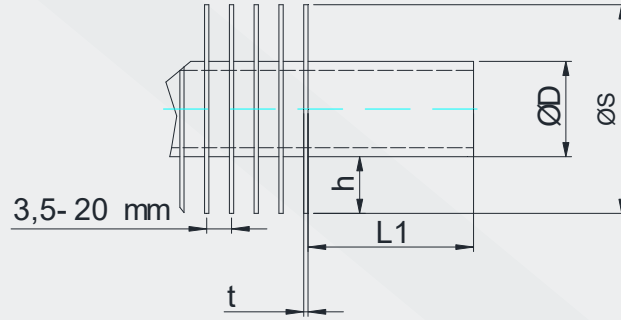

ÜRETİLEBİLİNER FİNLİ BORU TİP VE ÖLÇÜLERİ | FINNED TUBE DIMENSIONS

BORU ÇAPI		FİN MALZEMESİ YÜKSEKLİĞİ	
Inch	mm	DÜZ KANAT İÇİN Min / Max	KESİKLİ KANAT İÇİN Min / Max
1/2"	21,3	6,5 - 10 mm	6,5 - 16 mm
	25	6,5 - 13 mm	
	25,4	6,5 - 13 mm	
3/4"	26,9	6,5 - 16 mm	6,5 - 19 mm
	31,8	6,5 - 16 mm	
1"	33,7	6,5 - 19 mm	6,5 - 20 mm
	38	6,5 - 19 mm	
1 ¼"	42,4	6,5 - 20 mm	6,5 - 25 mm
	44,5	6,5 - 20 mm	
1 ½"	48,3	6,5 - 20 mm	
	51	6,5 - 20 mm	
	57	6,5 - 20 mm	
2"	60,3	6,5 - 20 mm	
2 ½"	76,1	6,5 - 20 mm	
3"	88,9	6,5 - 20 mm	
	101,6	6,5 - 20 mm	
4"	114,3	6,5 - 20 mm	



Enerji santrellerinde atık ısıdan yararlanarak proses ihtiyacı, kızgın buhar, buhar, kızgın ve sıcak su elde etmek için üretilen ekipmanlardır.

ASME ve EN standartlarına göre bundle üretimini, **Türkiye’de ilk ve tek üreticisi** olduğumuz **yüksek frekans kaynaklı kanatlı borular** ile yapmaktayız.

Ayrıca üretimini yapmış olduğumuz bundleların montajını da yaparak müşterimize komple çözüm sunmaktayız.

Bundles are used for generating superheated, saturated steam and hot water to meet the requirement of process by utilising waste heat in power plants.

We manufacture bundles according to ASME and EN standard with high frequency welded fintubes which is produced by Eralp.

Additionally, Eralp provides major solutions to their customers by making assembly of manufactured bundles.



Ekonomizerler, ısı, buhar veya güç üretim tesislerinde kazanlardan çıkarak bacaya verilen duman gazları üzerinde bulunan ısının bir bölümünü geri kazanmak amacıyla kullanılan bir çeşit su borulu ısı eşanjörleridir.

Ekonomizer gaz çıkış sıcaklığı, fuel oil yakıtlı kazanlarda **180°C**, motorin yakıtlı kazanlarda **160°C**, doğal gaz ve LPG yakıtlı kazanlarda **110°C** ye kadar düşürülebilir. Doğal gaz yakıtlı kazanlarda **50°C** ye kadar yoğuşmalı sistemlerde düşürülebilir.

Kazan duman gazı çıkış sıcaklığı ve yakıt cinsine bağlı olarak ve tesis edilecek ekonomizer sayısına bağlı olarak kazan veya tesis veriminde **%3 ile %8** arasında verim artışı sağlanır. Sürekli çalışan tesislerde geri kazanılan ısının bedelinin yapılacak ekonomizer tipine bağlı olarak yatırımı **5 ila 20 ay** arasında kendilerini amorti ettiği görülmüştür.

Ekonomizerlerimizi **Türkiye'nin ilk ve tek üreticisi olduğumuz "Yüksek Frekans Kaynaklı Kanatlı Boru"** ile üretmekteyiz.

Economizers are used for keeping waste energy after steam and power boiler as a water tube heat exchangers.

*Economizers reduce flue gas temperature to **180°C** in heavy fuel oil use, **160°C** in light fuel oil use and **110°C** in LPG use. It is possible to reduce flue gas **50°C** with condensation type.*

*Depending on fuel types, flue gas temperature and economizer quantity, total efficiency of system can be increased **%3 to %8**.*

*Depreciation time might be change **5-20 month** according to working time.*

We manufacture economizers by using high frequency welded fin tubes that is produced by Eralp.

TERMİK DEGAZÖRLER | THERMIC DEAERATORS



Termik degazörde kazan besi suyu içindeki korozif olan gazlar; besi suyu ısıtılıp özel ayrıştırma plaklarından geçirilerek ayrıştırılır ve kazan besi suyu standart değerlere çıkarılır. Genellikle bu tüp degazörler **95-102°C** arasındaki sıcaklıkta çalışırlar.

Eralp olarak özel dizaynımız sayesinde basınçlı ve basınçsız degazörler konusunda müşterilerimize hizmet vermekteyiz.

*Thermic deaerators intermediate plate separated Corrosive impurities in water for necessary quality inlet water according to standards Generally, thermic deaerators works between **95-102 °C** temperatures.*

As Eralp, according to customer demands, we provide service about pressured and non pressured deaerator thanks to our special design.

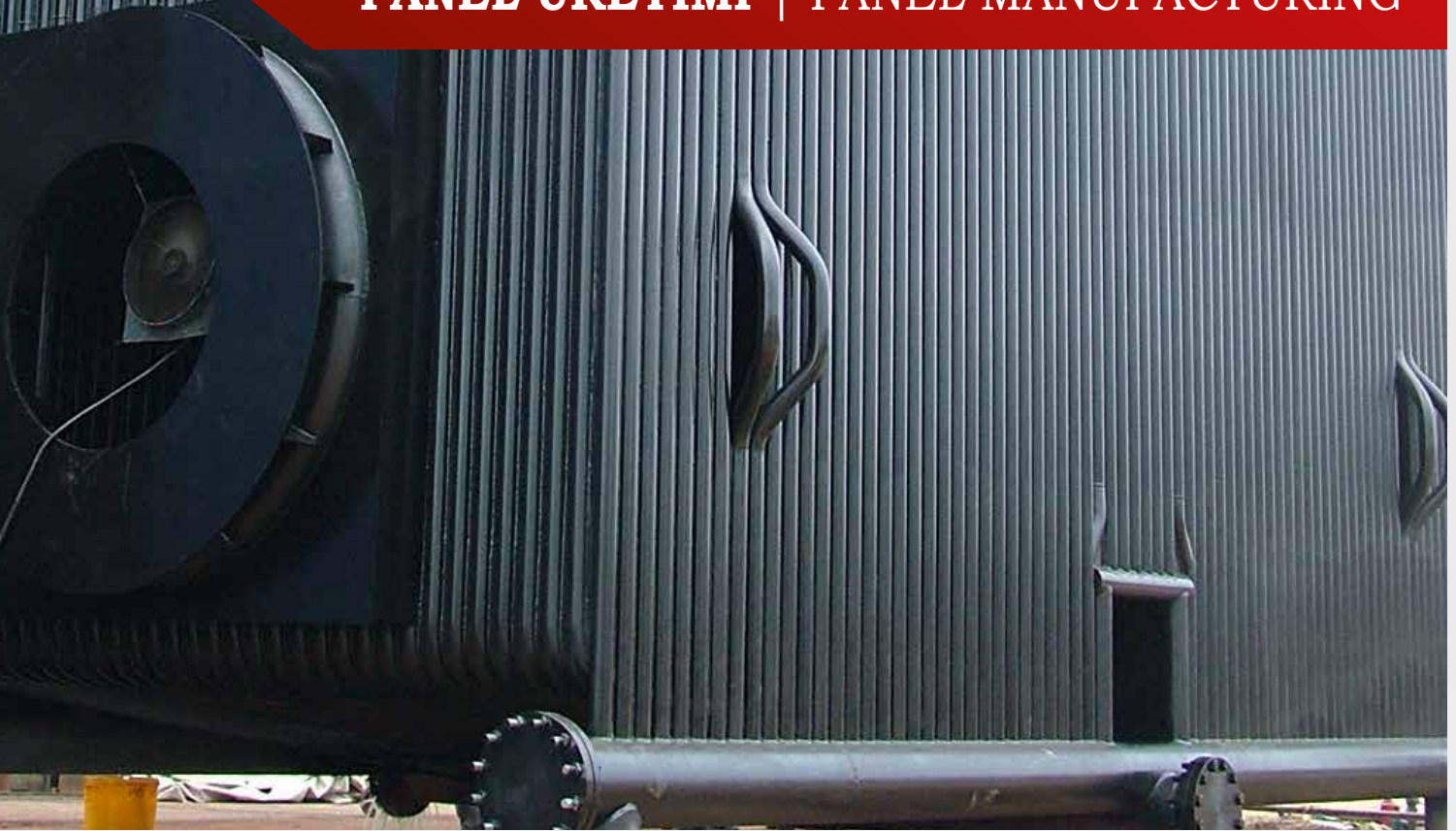

Eralp Kazan ve Enerji Teknolojileri olarak kendi kazanlarımıza enerji santrallerine, kazan üreticilerine ve bakım-onarım işleri yapan firmalara panel üretimi yapmaktayız.

Panel makinamız, tam otomatik Tozaltı kaynak makinası ile panel üretmektedir. Üretmiş olduğumuz paneller Tarafsız kuruluşlarca onaylanan WPS ve PQR kaynak belgelerine göre üretilmektedir.

Müşteri talep ve resimlerine göre çeşitli ebatlarda panel üretimi ve bükümü yapmaktayız.

Daha detaylı bilgi almak için lütfen bizimle irtibata geçiniz.

Eralp Boiler & Energy Technologies manufacture panel for our boiler and provide services to power plants, boiler manufacturer and boiler repair company about panel manufacturing.

We manufacture our panels with fully automatic sub-merged welding machine with approved WPS and PQR by Third Parties.

According to our customer demands, we are able to manufacture and bend panels.

Please don't hesitate to contact with us for more information.

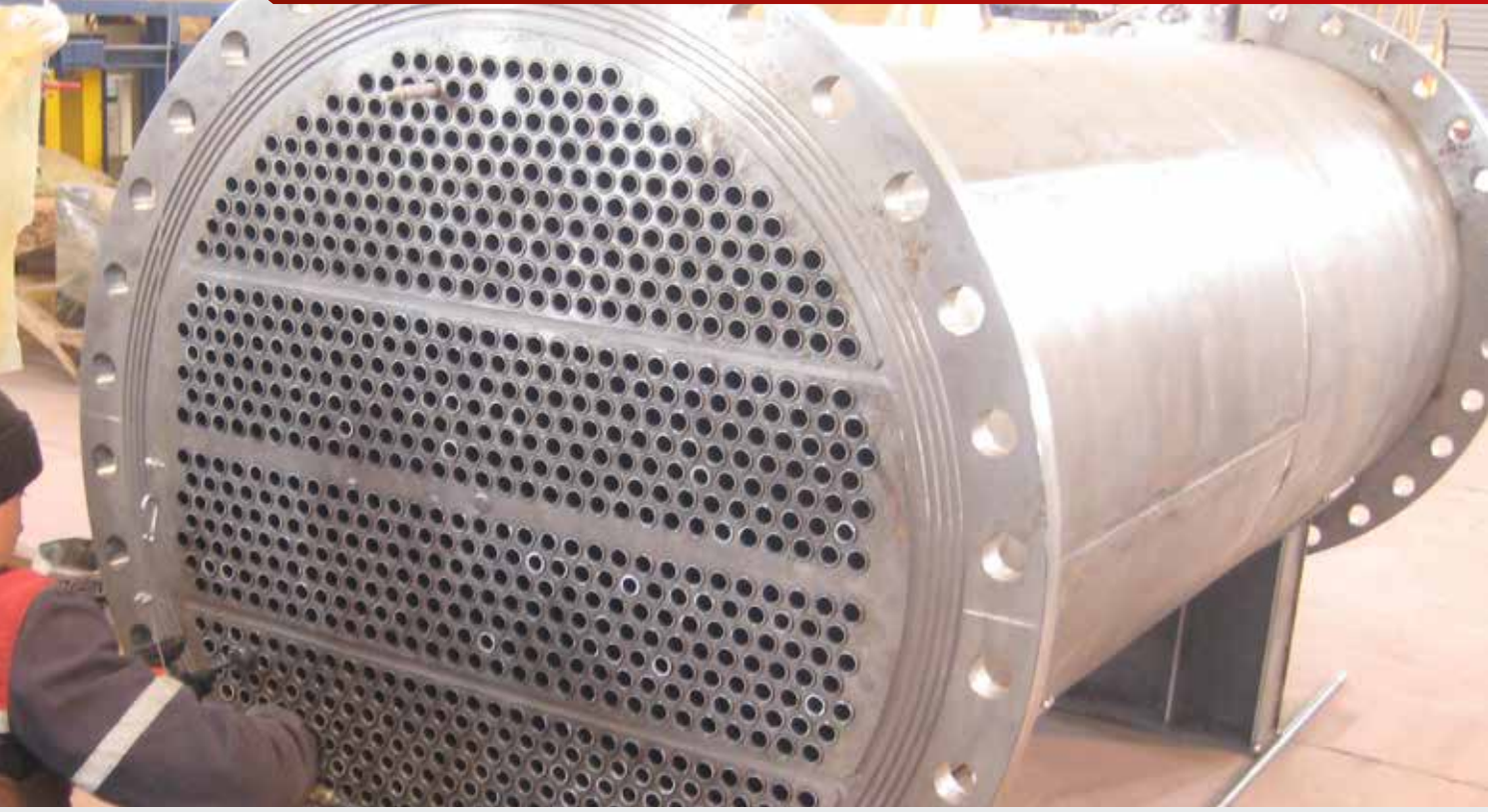

Bir akışkandan diğer bir akışkana ısı aktarmak için kullanılan ekipmanlara Isı değiştirgeçleri diğer bir adı ile eşanjörler denir.

Özellikle Rafineriler, kimya tesisleri ve tekstil sanayi başlıca eşanjör ihtiyacı olan sektörlerdir.

Eralp olarak, borulu ve Kanatlı Borulu Isı Eşanjörleri üretmekteyiz. Kanatlı borulu eşanjörlerimizi Türkiye'nin ilk ve tek üreticisi olduğumuz "Yüksek Frekans Kaynaklı Kanatlı Boru" ile yapmaktayız. Bu tür eşanjörlerde Carbon Steel ve Paslanmaz malzemelerden üretmekteyiz.

Borulu eşanjörlerde ise Bakır, Paslanmaz ve Carbon Steel malzemelerden üretimini yapmaktayız.

Yapılacak hesaplamalar veya müşterilerimizin önceden sahip olduğu eşanjörleri aynı ölçülerde üreterek müşterilerimize çözüm sunmaktayız.

Sahip olduğumuz belgeler sayesinde özellikle Rafineriler için gerekli **ASME Sertifikasyonuna** sahip eşanjörler üretebilmekteyiz.

A Heat exchanger is a device used to transfer heat between one or more fluids.

Especially refineries, chemical Industry and Textile Industry are main sectors that has need of heat exchangers.

As Eralp, we are manufacture Shell tube and Plate-Fin type exchangers. Our finned tubes is made by our High frequency welding machine. Also we are only one manufacturer of High Frequency welded fintube in Turkey.

We are able to manufacture our Shell Tube type exchanger with seamless steel, carbon steel and coper material.

It's possible to manufacture customers existing exchanger or new design.

*We can give a service and manufacture exchanger with **ASME Certification** that is especially required for refinery.*



Kimya endüstrisinde kimyasal ürünleri elde etmek için üretilen basınçlı ve basınçsız reaktörler firmamız bünyesinde prosese özel olarak üretilir.

Paslanmaz ve Carbon steel malzemelerden üretimi yapılan reaktörler, müşteri taleplerine göre kapasite olarak değişmektedir.

Taleplere göre karıştırıcılı veya karıştırıcısız, ceketli, yarım boru serpantinli, iç serpantinli reaktörler ürete bilmekteyiz.

Özel üretim reaktörleriniz için lütfen bizimle irtibata geçiniz

Pressured and non pressured reactors used in Chemical industry are manufactured specially for processes within the structure of our company.

Stainless steel and Carbon steel Reactors can be manufactured by ourself according to our customer demands.

Also, we are able to design and manufacture reactors including mixer, including exchanger etc. according to demands.

Please don't hesitate to contact with us about your specific reactors.

ONDÜLE KÜLHAN | CORRUGATED FURNACE



Buhar Kazanlarında yanmanın büyük bölümünün gerçekleştiği ekipmana külhan denilmektedir. Külhanlar yapı itibari ile düz ve ondüle olmak üzere ikiye ayrılırlar.

Düşük basınçlar için düz külhan kullanılır iken, yüksek basınç ve uzun ömür için ondüle külhanlar tercih edilirler.

Ondüle külhanlar da EN 12953-3 te tarif edilen Morisson ve Fox tipi olarak da hatve çeşidine göre ikiye ayrılırlar.

Ondüle külhanlar üretimi de kendi arasında Sıcak Basım külhan yapımı ve Soğuk Basım Ondüle Külhan yapımı olarak ikiye ayrılır.

Sıcak basım işlemi **900°C** de olmasından dolayı ürünün tekrar Normalizasyon tavına tabii tutulması gerekmez. Ancak soğuk basım ile üretilen külhanlar üretim sonrasında **900°C** de Normalizasyon işlemine tabii tutulmalıdırlar.

Eralp olarak gerek kendi ürünlerimize gerek ise diğer kazan üreticilerine **900°C** de Sıcak basım Fox tipi ondüle külhan üretimi yapmaktayız.

There is two type furnaces for shell tube boilers which first is corrugated, second is plain type. Corrugated furnace is more strength and more flexible than plain type.

Generally, plain type furnace use for low pressure Fox type furnace use for high pressure and longevity.

According to EN 12953-3 stadard; corrugated furnaces divide into Fox type or Morisson type and hot formed corrugated furnace or cold formed corrugated furnace.

*Normalization heat treatment in **900°C** degrees must be done after manufactured cold formed corrugated furnace.*

*Hot formed corrugated furnaces don't need this treatment because forming is done in **900°C** degrees.*

*We manufactured hot formed Fox type furnace in **900°C** degrees for our boilers and other boiler manufacturer all over the World.*



CERTIFICATE OF AUTHORIZATION

The named company is authorized by the American Society of Mechanical Engineers (ASME) for the scope of activity shown below in accordance with the applicable rules of the ASME Boiler and Pressure Vessel Code. The use of the certification mark and the authority granted by this Certificate of Authorization are subject to the provisions of the agreement set forth in the application. Any construction stamped with this certification mark shall have been built strictly in accordance with the provisions of the ASME Boiler and Pressure Vessel Code.

COMPANY:
ERALP BOILER AND ENERGY TECHNOLOGIES
Mustafa Kemal Paşa OSB 3, Cad. No.11
Mustafa Kemal Paşa
Bursa 16500
Turkey

SCOPE:
Manufacture and assembly of power boilers at the above location and field sites controlled by the above location

AUTHORIZED: June 4, 2015
EXPIRES: June 4, 2018
CERTIFICATE NUMBER: 46,984

Vice President, Conformity Assessment

Director, Conformity Assessment

The American Society of Mechanical Engineers



CERTIFICATE OF AUTHORIZATION

The named company is authorized by the American Society of Mechanical Engineers (ASME) for the scope of activity shown below in accordance with the applicable rules of the ASME Boiler and Pressure Vessel Code. The use of the certification mark and the authority granted by this Certificate of Authorization are subject to the provisions of the agreement set forth in the application. Any construction stamped with this certification mark shall have been built strictly in accordance with the provisions of the ASME Boiler and Pressure Vessel Code.

COMPANY:
ERALP BOILER AND ENERGY TECHNOLOGIES
Mustafa Kemal Paşa OSB 3, Cad. No.11
Mustafa Kemal Paşa
Bursa 16500
Turkey

SCOPE:
Manufacture of pressure vessels at the above location and field sites controlled by the above location (This authorization does not cover impregnated graphite)

AUTHORIZED: June 4, 2015
EXPIRES: June 4, 2018
CERTIFICATE NUMBER: 46,985

Vice President, Conformity Assessment

Director, Conformity Assessment

The American Society of Mechanical Engineers



CERTIFICATE

IQNet and TSE hereby certify that the organization

ERALP MAK. KAZAN KİMYA VE EKİPMANLARI SAN. VE TİC. LTD. ŞTİ.

MUSTAFA KEMALPAŞA ORGANİZE SAN. BÖL. 3 NOLU CAD. NO:11 MUSTAFAKEMALPAŞA - BURSA / TÜRKİYE

has implemented and maintains a
QUALITY MANAGEMENT SYSTEM
which fulfills the requirements of the following standard

TS EN ISO 9001:2008

Issued on: 31-03-2018
Validity date: 14-09-2018

Registration Number : TR-KY-3713-05/09-R



Michael Drechsel
President of IQNet

Gökten Bircan Değerliyurt
Head of System Certification Group

IQNet Partners:
ANZSAC Spain, APNOR Certification France, ABS (Vapeur) International Belgium, APCCC Portugal
CBQ Italy, IQE China, IQM (China), IQE (South Republic), CTS Cert (Croatia), IQR (Building) GmbH Germany
PCCE (Small Pressure Vessels) Venezuela, ISO/IEC, Colson BSC, Bvsc (Singapore) Certification, Pineda (PINEDA) Costa Rica
BSM (Argentina), JQA (Japan), KIQ (Korea), BSSTEC (China), MET (Hungary), WSA (Austria), NIAJ (Jordan), PCRC (Kuwait)
Quality Australia, RIA (Russia), RQI (Mexico), SRI (Israel), IQI (Bahrain), IQM (Qatar), IQM (International) Malaysia
IQI (International) (SAC) Romania, TSBT (S) (Finland), Pcsocert (Turkey), TSCA (Turkey)
IQNet is registered in the USA by APNOR Certification, COO, COE, holding GmbH and IQM Inc.
* The size of IQNet partners is held at the size of issue of this certificate. Updated information is available under www.iqnet-certification.com



Annex to IQNET Certificate Number :TR-KY-3713-05/09-R

Name and Address of the certified organization:
ERALP MAK. KAZAN KİMYA VE EKİPMANLARI SAN. VE TİC. LTD. ŞTİ.

MUSTAFA KEMALPAŞA ORGANİZE SAN. BÖL. 3 NOLU CAD. NO:11 MUSTAFAKEMALPAŞA - BURSA / TÜRKİYE

Scope of the Certificate

- DESIGN, PRODUCTION AND SALES OF
 - STEAM BOILER
 - THERMAL OIL HEATER
 - HEAT RECOVERY BOILER
- FIN TUBES WITHOUT WELDING AND WITH HIGH FREQUENCY WELDING
 - WATER TUBE BOILER
 - AUTOCLAVE
 - STEAM STORAGE TANK
 - HEAT EXCHANGER
 - WATER TREATMENT SYSTEMS
 - HYDROPHONE
- PRESSURE TANKS AND OTHER SPECIAL PROJECT
- PRODUCTION AND SALES OF
 - TEXTILE AUXILIARIES
 - BOILER WATER TREATMENT CHEMICALS
 - INDUSTRIAL WASTE WATER TREATMENT CHEMICALS
 - CONSTRUCTION CHEMICALS
 - PULP AND PAPER CHEMICALS
 - BASIC INDUSTRIAL CHEMICALS
 - COOLING TOWER WATER TREATMENT CHEMICALS

This annex is only valid in connection with the above-mentioned certificate



TURKISH STANDARDS INSTITUTION





TUV NORD

CERTIFICATE

The Certification Body
of TÜV NORD Systems GmbH & Co. KG

certifies that the company

ERALP MAKİNE
KAZAN KİMYA VE EKİPMALARI SAN. TIC. LTD. ŞTİ.
Organize Sanayi Bölgesi 3 Cd. No. 11 / BURSA

has been verified and recognized
as manufacturer of

**Pressure equipment, tanks, piping systems and welded
constructions**

according to the rules of

AD 2000-Merkblatt HP0

Certificate-no.: 07-203-9200-HP-3760/14

The range of validity and details of the inspection can be taken from our

Report-no.: 9200AS_3760/14 // SAP: 8111616442

The company has established a product-related quality system
together with personnel and equipment which ensures
manufacturing and testing conforming to the technical rules

This certificate is valid until

March 2017

Hamburg, 11.09.2014



TÜV NORD Systems GmbH & Co. KG • Technisches Zentrum •
Certification Body for Pressure Equipment (Merkblatt HP0, Reg.-Nr. 2000)
Größe Bahnstraße 31 • 22525 Hamburg
Telefon +49 (0)40 8557-0 • Fax +49 (0)40 8557-2710 • E-Mail: technikzentrum@tuv-nord.de

TUV NORD

CERTIFICATE

The Certification Body for Pressure Equipment
of TÜV NORD Systems GmbH & Co. KG

certifies that the company

ERALP MAKİNE
KAZAN KİMYA VE EKİPMALARI SAN. TIC. LTD. ŞTİ.
Organize Sanayi Bölgesi 3 Cd. No. 11 / BURSA

has been verified and recognized
as welding workshop in the product range of

**Pressure equipment, tanks, piping systems and welded
constructions**

based on the requirements of the standard

DIN EN ISO 3834-2

Certificate-no.: 07-202-9200 EN 3760/14

The range of validity and details of the inspection can be seen in our

Report-no.: 9200AS_3760/14 // SAP: 8111616442

The company is using a quality electronic system,
technical equipment, qualified personnel and procedures for joining processes
for manufacturing and testing of welded products

This certificate is valid until

March 2017

Hamburg, 11.09.2014



TÜV NORD Systems GmbH & Co. KG • Technisches Zentrum • Certification Body for Pressure Equipment
Größe Bahnstraße 31 • 22525 Hamburg
Telefon +49 (0)40 8557-0 • Fax +49 (0)40 8557-2710 • E-Mail: technikzentrum@tuv-nord.de

TUV NORD

CERTIFICATE

Verification of manufacturer
for pressure vessels
according to Pressure Equipment Directive 97/23/EC

Certificate-No.: 07-202-9200 HZ-3760/14

Name and address of manufacturer: **ERALP MAKİNE**
KAZAN KİMYA VE EKİPMALARI SAN. TIC. LTD. ŞTİ.
Organize Sanayi Bölgesi 3 Cd. No. 11 / BURSA

This is to certify that the manufacturer has demonstrated proven experience for unit verification according to directive 97/23/EC and fulfils the standard quality requirements.

Verification: **Manufacturing according to directive 97/23/EC Annex I, Appendix 3.1**

Technical rule / regulation: **PED 97/23/EC / AD 2000-Merkblatt HP0 / DIN EN ISO 3834-2**

Test report no.: **9200AS_3760/14 // SAP: 8111616442**

Scope: **Pressure equipment, tanks, piping systems and welded constructions**

Manufacturing location: **Organize Sanayi Bölgesi 3 Cd. No. 11 / BURSA**

Valid until: **March 2017**

Hamburg, 11.09.2014



Certification Body for Pressure Equipment
of TÜV NORD Systems GmbH & Co. KG

TÜV NORD Systems GmbH & Co. KG • Tel. +49 (0) 40 8557 2288
Größe Bahnstraße 31 • Fax +49 (0) 40 8557 2710
22525 Hamburg • E-Mail: hamburg@tuv-nord.de

РОССИЙСКАЯ ФЕДЕРАЦИЯ
СЕРТИФИКАТ СООТВЕТСТВИЯ
(областное соответствие)

№ **C-TA103.B.02826** TP **1159819**

ЗАЯВИТЕЛЬ: "ERALP MACHINE BOILER CHEMICAL INDUSTRY COMMERCE LIMITED COMPANY". Адрес: ORGANIZE INDUSTRY AREA 3, STREET NO.11 MUSTAFA KEMALPAŞA BURSA, Турция. Телефон +90 224 632 60 70.

ИЗГОТОВИТЕЛЬ: "ERALP MACHINE BOILER CHEMICAL INDUSTRY COMMERCE LIMITED COMPANY". Адрес: ORGANIZE INDUSTRY AREA 3, STREET NO.11 MUSTAFA KEMALPAŞA BURSA, Турция. Телефон +90 224 632 60 70.

ОПЕРАТОР ПО СЕРТИФИКАЦИИ ООО "Алькор" 3-я Мытищинская улица, дом 3, строение 1, офис 405, Москва, 129626, тел. +7(499)706 80 36, E-mail: alkor@yandex.ru
ОПРЕДЕЛЯЮЩИЙ ЦЕНТР: Котельный завод имени С.С.Степанова, 3-й этаж и подполночные части, Московская область, г.Тарасовский район.

СООТВЕТСТВУЕТ ТРЕБОВАНИЯМ Технический регламент о безопасности承压设备的 (Постановление Правительства РФ от 15.09.2009 N 752 с изменениями, утвержденное постановлением Правительства РФ от 24.03.2011 N 205), ГОСТы в приложении см. банк №0290388.

ПРОЕКЦИОННЫЕ ИССЛЕДОВАНИЯ: Проект компаний № А301-А/7-046 от 13.04.2012 г. ИЛ ООО (ИСПЫТАНИЯ) И ИЗМЕРЕНИЯ: "Испытатель промышленной политики" (РОСС RU.0001.21M347)

ПРЕДСТАВЛЕННЫЕ ДОКУМЕНТЫ: Место нанесения знака соответствия, ее сопроводительной технической документации. Форма и размеры знака по ГОСТ Р 50469-02.

СРОК ДЕЙСТВИЯ СЕРТИФИКАТА СООТВЕТСТВИЯ с **11.04.2012** по **10.04.2017**

Руководитель: **В.С. Оганян**
Специалист: **И.С. Митраш**







BAZI REFERANSLARIMIZ | SOME REFERANCES

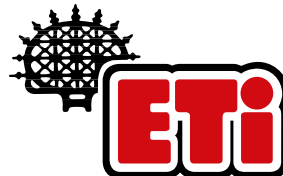



P Bar (Atü)	Tbh °C	Entalpi (kcal/kg)			Özgül Hacim	Özgül Ağırlık
		Su İçin	Buharlaştırma Isısı	Doymuş Buhar		
0.0	100	99,7	539,4	639,1	1,6940	0,590
0.1	102,3	102,4	537,7	640,1	1,5490	0,646
0.2	104,8	105,0	536,1	641,1	1,4280	0,700
0.3	107,1	107,3	534,6	641,9	1,3250	0,755
0.4	109,3	109,5	533,2	642,7	1,2360	0,809
0.5	111,4	111,6	531,8	643,4	1,1590	0,863
0.6	113,3	113,6	530,6	644,1	1,0910	0,917
0.8	116,9	117,2	528,1	645,4	0,9772	1,023
1	120,2	120,6	525,9	646,5	0,8854	1,129
1,2	123,3	123,7	523,9	647,5	0,8098	1,235
1,4	126,1	126,5	522,0	648,5	0,7465	1,340
1	127,4	127,9	521,0	648,9	0,7184	1,392
1,6	128,7	129,2	520,1	649,3	0,6925	1,444
1,8	131,2	131,7	518,4	650,2	0,6460	1,548
2	133,5	134,1	516,8	650,9	0,6056	1,651
2,2	135,8	136,4	515,2	651,6	0,5700	1,754
2,4	137,9	138,5	513,7	652,3	0,5385	1,857
2,6	139,9	140,6	512,3	652,9	0,5103	1,960
2,8	141,8	142,6	510,9	653,5	0,4851	2,061
3	143,6	144,5	509,6	654,0	0,4622	2,164
3,5	147,9	148,9	506,4	655,2	0,4132	2,42
4	151,8	152,9	503,4	656,4	0,3747	2,669
4,5	155,5	156,7	500,7	657,4	0,3425	2,920
5	158,1	160,2	498,1	658,2	0,3155	3,170
5,5	162,0	163,4	495,6	659,1	0,2925	3,419
6	165,0	166,5	493,3	659,8	0,2727	3,667
6,5	167,8	169,4	491,0	660,5	0,2552	3,918
7	170,4	172,2	488,9	661,1	0,2403	4,161
7,5	172,9	174,9	486,8	661,7	0,2268	4,409
8	175,4	177,4	484,8	662,2	0,2148	4,655
8,5	177,7	179,8	482,8	662,6	0,2040	4,902
9	179,9	182,2	481,0	663,2	0,1943	5,147
10	184,1	186,6	477,4	664,0	0,1774	5,637
11	188,0	190,7	474,0	664,8	0,1632	6,127
12	191,6	194,6	470,8	665,4	0,1511	6,618
13	195,0	198,3	467,7	666,0	0,1407	7,107
14	198,3	201,8	464,7	666,5	0,1317	7,593
15	201,4	205,1	461,8	666,9	0,1237	8,048
16	204,3	208,3	459,0	667,3	0,1166	8,576
17	207,1	211,3	456,4	667,7	0,1103	9,066
18	209,8	214,2	453,7	668,0	0,1047	9,551
19	212,4	217,1	541,2	668,2	0,0995	10,050
20	214,9	219,8	448,7	668,5	0,0949	10,539
21	217,2	222,4	446,3	668,7	0,0907	11,031
22	219,6	224,9	443,9	668,8	0,0868	11,525

Factory/Fabrika:

Organize Sanayi Bölgesi 3. Cadde No:11
16500 Mustafakemalpaşa BURSA / TURKEY
Tel : +90 224 632 60 72 - 73
Fax: +90 224 632 60 80

Brach Office/Merkez Ofis:

Uludağ Üniversitesi Ulutek Teknoloji Geliştirme Bölgesi
Üniversite 1. Cad. No: 931 İç Kapı: 4 16059
Görükle / BURSA / TURKEY
Tel : +90 224 632 60 70 - 71
Fax: +90 224 632 60 80

www.eralpkazan.com



ERALP[®]
BOILER AND ENERGY TECHNOLOGIES