



Great Turning Centers



GT-40/80/120/160/200/240
275/320/355/395

Great Turning Centers



GT-80 / 275

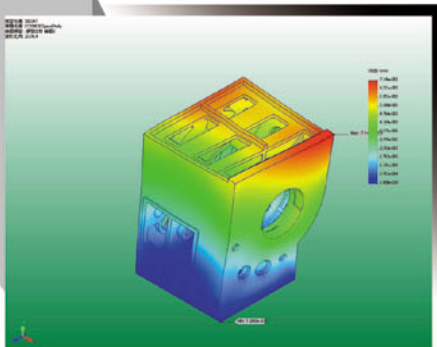

Quality

Solidworks advanced engineering software is utilized for optimizing the design of the GT Series. It is used to calculate the physical and material properties of the components. ANSYS Finite element analysis (FEA) software is employed to analyze all components of the GT series to determine the optimal machine structure.

Both of the softwares help us to refine our design and ensure our machines without weakness.

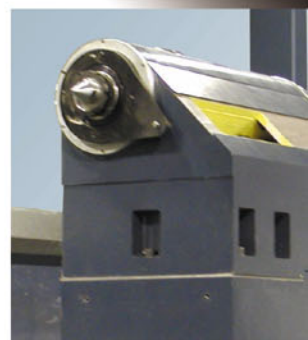

GT- (+C)

Option
C: C Axis

Spindle Type

D : Bore ϕ 7" (ϕ 185 mm) /A2-15/1000 rpm
 E : Bore ϕ 9" (ϕ 235 mm) /A2-15/750 rpm
 F : Bore ϕ 10" (ϕ 255 mm) /A2-15/600 rpm
 G : Bore ϕ 12" (ϕ 318 mm) /A2-20/500 rpm
 H : Bore ϕ 14" (ϕ 360 mm) /A2-20/400 rpm
 I : Bore ϕ 16" (ϕ 410 mm) /A2-28/300 rpm
 J : Bore ϕ 21" (ϕ 535 mm) /A2-28/250 rpm
 K : Bore ϕ 24" (ϕ 610 mm) /A2-32/220 rpm

Model (Z Axis Travel)

40 = 1000mm	240 = 6000mm
80 = 2000mm	275 = 7000mm
120 = 3000mm	320 = 8000mm
160 = 4000mm	355 = 9000mm
200 = 5000mm	395 = 10000mm

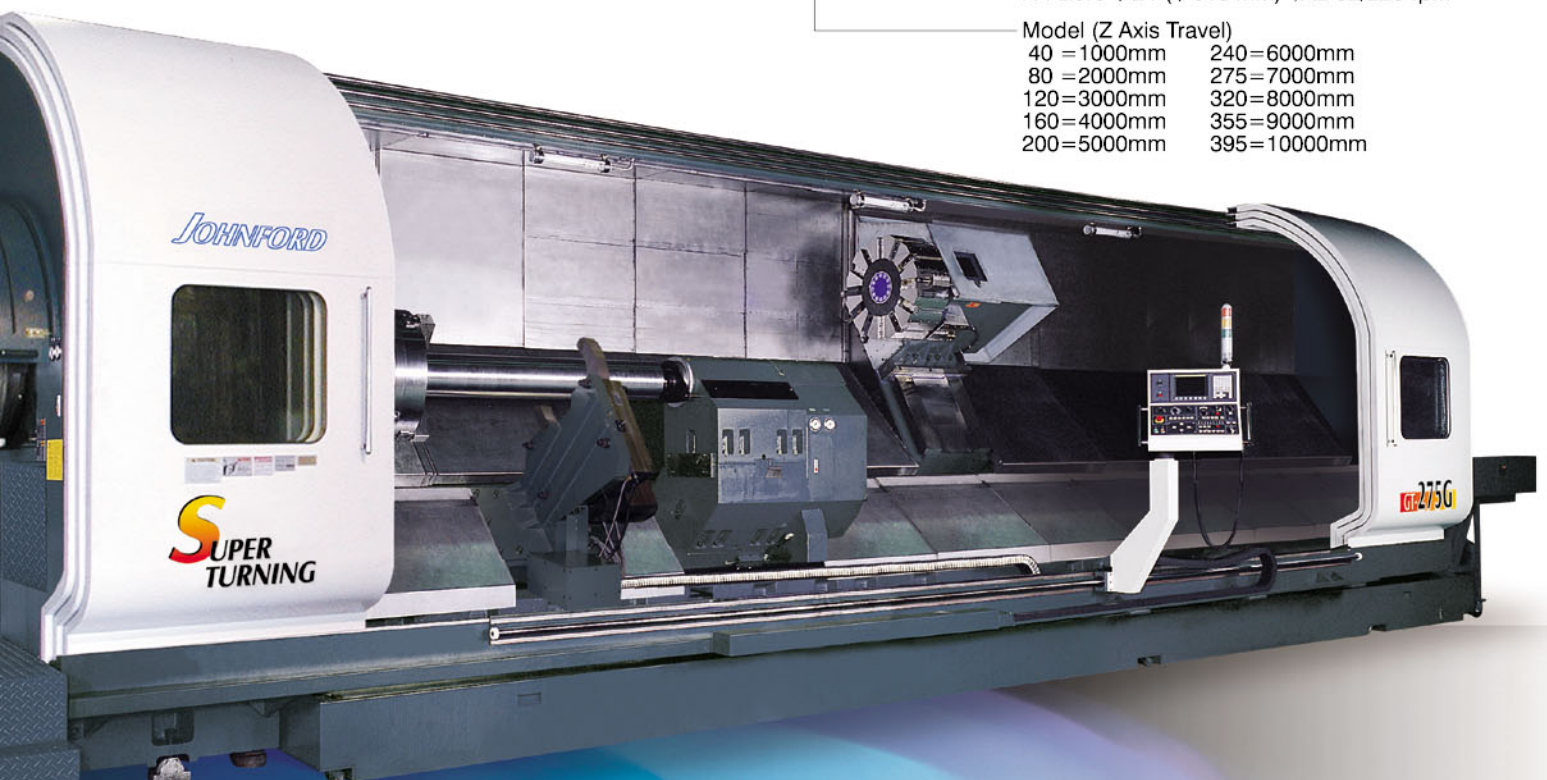

**Johnford Offers You the Best Performance
in Large Turning Centers with Our
Advanced Manufacturing Ability**

**Programmable Hydraulic
Tailstock**

Tailstock is designed for heavy duty operation and is fully automatic. Tailstock body and spindle is programmable and can also be operated by manual switches.

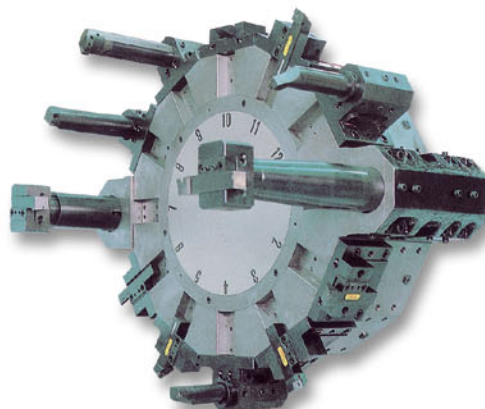

12-Position Vertical Turret

The heavy duty cutting turret with a clamping force of 20,000kg (35kg/cm²) and large cutting tool capacity provides for the use of ϕ 100mm diameter boring bar.

The turret indexing is a non-stop random selection system and allows high-speed indexes.

Powerful Spindle for Heavy Duty Cutting

Powerful Spindle for Heavy Duty Cutting

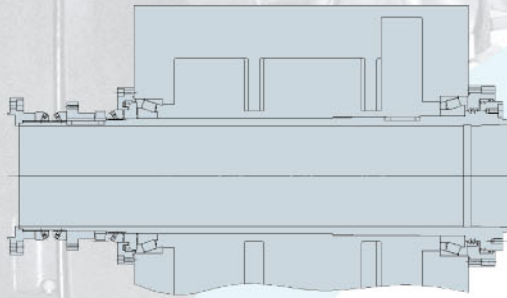

Headstock is a thick wall casting with special ribs arranged for maximum rigidity.

The main spindle adopts JOHNFORD's own 2-point supporting system. We can provide large size spindle bores: $\phi 185$, $\phi 235$, $\phi 255$, $\phi 318$, $\phi 360$, $\phi 410$, $\phi 535$, $\phi 610$ mm.

The 4-step geared headstock with automatic hydraulic shift and constant surface speed control ensures the proper cutting speed for a better surface finish and longer tool life while delivering awesome cutting power at any speed.

Tooling System

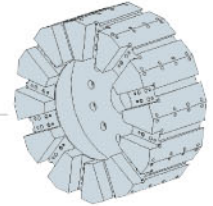
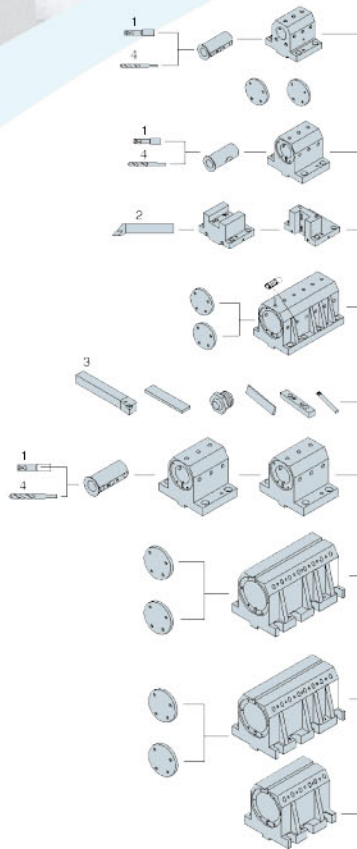

No.	Model Taper Tool	Metric System	Empiral System
1	Bore	$\phi 12$, $\phi 16$, $\phi 20$, $\phi 25$	1/2", 1", 1-1/4"
		$\phi 32$, $\phi 40$, $\phi 50$	1-1/2", 1-3/4"
2	End	<input type="checkbox"/> 32	<input type="checkbox"/> 1" / <input type="checkbox"/> 1-1/4"
3	Outerdia	<input type="checkbox"/> 32	<input type="checkbox"/> 1" / <input type="checkbox"/> 1-1/4"
4	Drill	MT#2, #3, #4, #5	

12-Angle Turret Working Capacity / Range

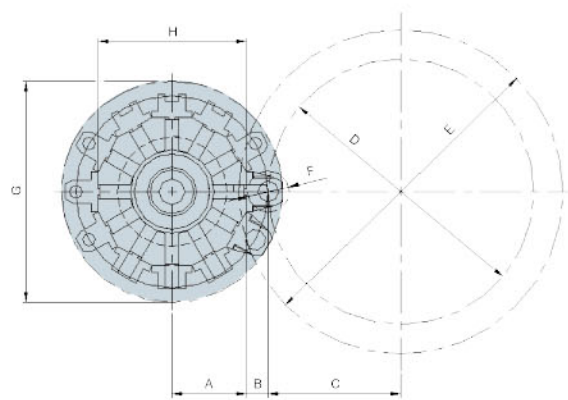
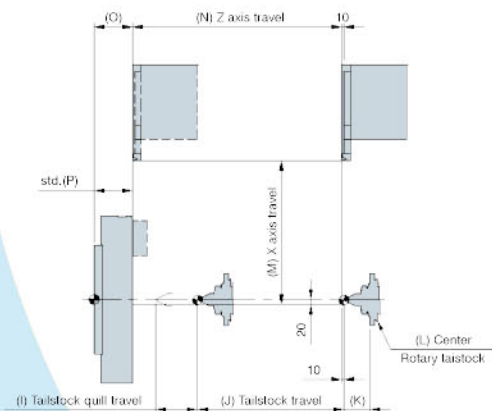

Model	Item	A	B	C	D	E	F	G	H	I	J	K	L	M	N
GT-40											700 (27.6")				1000 (39.4")
GT-80											1700 (66.9")				2000 (78.7")
GT-120											2700 (106.3")				3000 (118.1")
GT-160											3700 (145.7")				4000 (157.5")
GT-200	355	105	635	1270	1550	200	1060	710	200		4700 (185")	125.5	MT#7	685	5000 (196.9")
GT-240	(14")	(4.1")	(25")	(50")	(61")	(7.9")	(41.7")	(28")	(7.9")		5700 (224.4")	(4.9")		(27")	6000 (236.2")
GT-275											6700 (263.8")				7000 (275.6")
GT-320											7700 (303.1")				8000 (315")
GT-355											8700 (342.5")				9000 (354.3")
GT-395											9700 (381.9")				10000 (393.7")

Spindle Type	O	P
A Type	122 (4.8")	122 (4.8")
B Type	149 (5.9")	149 (5.9")
C Type	155 (6.1")	155 (6.1")
D Type	155 (6.1")	155 (6.1")

Power Turret with C-Axis/C+Y-Axis Function

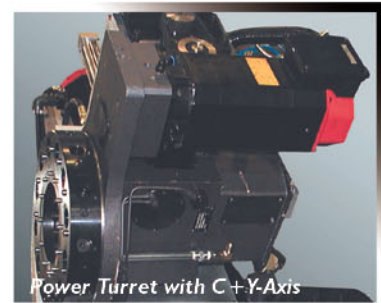
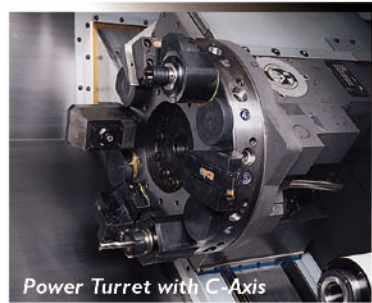
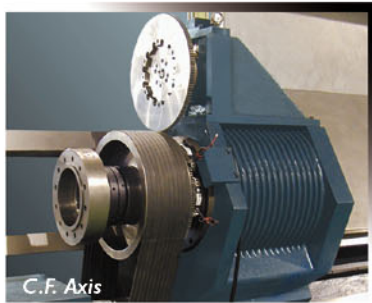

C-axis or C+Y-axis provides flexible turning performance for handling cam or special profiled parts that need milling / drilling / tapping operations. 0.001 degree indexing allows accurate circular positioning.

Examples for Machining with Live Tools

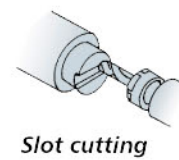
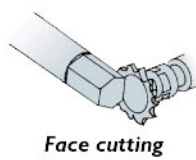
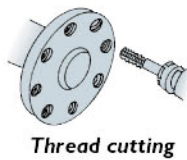

Standard Features-Great Equipment

Item	Model	GT-40, 80, 120, 160, 200, 240, 275, 320, 355, 395 Series	GT-40~395 (All Series with Y-Axis)
Power turret model		TBMA 320	TBMA 400
Max. speed of turret		2000 rpm	3276 rpm
Twist drilling	$d \times a$ (mm)x(mm/μ)	25 x 0.5	22 x 0.20
Slot milling	$d \times P \times a$ (mm)x(mm)x(mm/min)	40 x 20 x 35 (1.57" x 0.79" x 1.38")	25 x 20 x 40 (0.98" x 0.79" x 1.57")
Tapping	$d \times p$ (mm)x(mm)	M24 x 3	M18 x 2
Toolholder shaft size		φ 60	φ 50
Motor horsepower		AC 5.5 / 7.5 kW	AC 5.5 / 3.7 kW

Dimensions

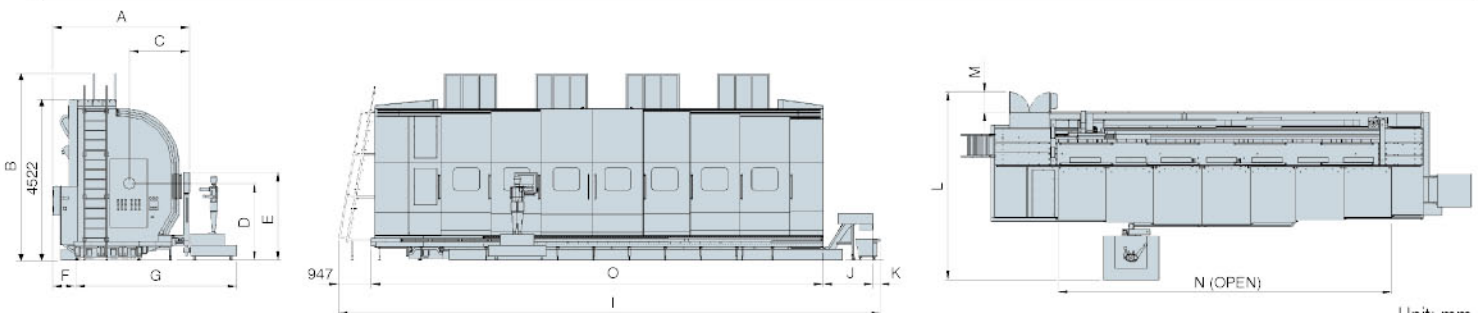

Unit: mm

Model	Item	A	B	C	D	E	F	G	I	J	K	L	M	N	O
GT-40									8800 (346.4")					2240 (88.2")	7733 (304.5")
GT-80									9900 (389.8")					3240 (127.6")	8833 (347.8")
GT-120									11000 (433")					4240 (166.9")	9933 (391")
GT-160									12100 (476.4")					5240 (206.3")	11033 (434.4")
GT-200	4018 (158.2")	5470 (215.4")	1770 (69.7")	2249 (88.5")	2571 (101.2")	671 (26.4")	5389 (212.2")		13200 (519.7")	1470 (57.9")	223 (8.8")	5812 (228.8")	650 (25.6")	6240 (245.7")	12133 (477.7")
GT-240									14300 (563")					7240 (285")	13233 (521")
GT-275									15400 (606.3")					8240 (324.4")	14333 (564.3")
GT-320									16500 (649.6")					9240 (363.8")	15433 (607.6")
GT-355									17600 (692.9")					10240 (403.1")	16533 (650.9")
GT-395									18700 (736.2")					11240 (442.5")	17633 (694.2")

Specifications

Item	Model	GT-40	GT-80	GT-120	GT-160	GT-200	GT-240	GT-275	GT-320	GT-355	GT-395
Swing over bed (mm)		φ 1550									
Swing over cross slide (mm)		φ 1270									
Distance between centers (mm)		1000 (39.3")	2000 (78.7")	3000 (118.1")	4000 (157.5")	5000 (196.9")	6000 (236.2")	7000 (275.6")	8000(315")	9000 (354.3")	10000 (393.7")
Chuck size (in)		D: 20" / E, F, G, H, I: 24" / J, K: 40"									
Spindle nose		D, E, F: A2-15 / G, H: A2-20 / J, I: A2-28 / K: A2-32									
Spindle bore (mm)		D: φ 185 / E: φ 235 / F: φ 255 / G: φ 318 / H: φ 360 / I: φ 410 / J: φ 535 / K: φ 610									
Spindle speed step (s)		Auto 4-speeds									
Spindle speed range (rpm)		D: 1000 / E: 750 / F: 600 / G: 500 / H: 400 / I: 300 / J: 250 / K: 220									
Spindle motor (kW)		30 / 37					37 / 45				
Spindle bearing diameter (mm)		D: φ 240 / E: φ 280 / F: φ 305 / G: φ 381 / H: φ 457 / I: φ 508 / J: φ 610 / K: φ 700									
No. of tools		12									
Cross travel (X-axis) (mm)		685 (27")									
Longitudinal travel (Z-axis) (mm)		1000 (39.3")	2000 (78.7")	3000 (118.1")	4000 (157.5")	5000 (196.9")	6000 (236.2")	7000 (275.6")	8000 (315")	9000 (354.3")	10000 (393.7")
Rapid traverse (m/min)		X: 12 / Z: 15	X: 10 / Z: 12			X: 10 / Z: 10					
Tailstock travel (mm)		700 (27.6")	1700 (66.9")	2700 (106.3")	3700 (145.6")	4700(185")	5700(224.4")	6700(263.8")	7700(303.1")	8700(342.5")	9700(381.9")
Tailstock quill travel (mm)		200 (7.9")									
Tailstock quill diameter (mm)		φ 200 (7.9")									
Tailstock Spindle taper (Rotary)		MT#7									
Servo motor (X-axis) (kW)		7									
Servo motor (Z-axis) (kW)		7			9						
Bed inclination		45°									
Weight (kg) (lb)		27650 (60830)	32600 (71720)	36350 (79970)	40700 (89540)	45050 (99110)	49400 (108680)	53750 (118250)	58100 (127820)	62450 (137390)	66800 (146960)
Machine Dimensions (mm)	W x H	4050 x 4700 (159.4" x 185")									
	L	8900 (350.4")	9900 (389.7")	10900 (429.1")	11900 (468.5")	12900 (507.8")	13900 (547.2")	14900 (586.6")	15900 (626")	16900 (665.3")	17900 (704.7")

■ All data subject to change without notice.

■ All the specifications are listed with the FANUC CNC system and 12-angle turret.

Standard Accessories:

1. Coolant system
2. Splash guard
3. Through hole 3-jaw chuck
4. Programmable hydraulic tailstock
5. Chain type chip conveyor
6. Tool box and various manuals
7. Tool holders (direct mounting type)
8. Auto lubrication with alarm
9. Halogen work lamp

Optional Accessories:

1. C-axis (Live Tooling)
2. Contact tool setting system
(Renishaw TS-20 or BULM NT-A2 / NT-A3)
3. Tool holders (VDI type)
4. Twin spindle

CNC Control Specs

■ CNC system type

O: Std. △: Opt. -: Nil

Type	Model	GT-40~395
Fanuc 0i-TC		○
Fanuc 21i/T		△
Fanuc 18i/T		△
Siemens 810D		△
Siemens 840D (572.5)		△
Siemens 840D (573.5)		△

■ Fanuc specifications

O: Std. △: Opt. -: Nil

	Item	Specifications	0iTC	18i/T	21i/T	
Display unit	7.2" mono LCD		○	-	-	
	8.4" color LCD		△	-	-	
	10.4" color LCD		△	○	○	
Function	Data Server with 1GB CF card		△	△	△	
	NC program memory	640M (256KB)	○	○	○	
	Conversational programming with graphic function	Manual guide 0i	0iTC	○	-	-
		Manual guide i	18i/T / 21i/T / 0iTC (10.4" LCD)	△	○	○
	No. of tool offset sets		64	16	16	
	No. of variable command sets		500	100	100	
Work coordinate system	G54~G59		○	△	△	

■ Siemens specifications

O: Std. △: Opt. -: Nil

	Item	Specifications	810D	840D
Operator Panel	10.4" color LCD		○	○
	12.1" color LCD		△	△
	15.1" color LCD		△	△
	KB 483C full CNC keyboard		△	△
	PCU 20 without hard disk		○	○
	Network / disk drive management	CF card	△	△
Function	PCU 50 with hard disk	Include HD & Ethernet	△	△
	ShopTurn operation copy licence		○	○
	ShopTurn programming copy licence		△	△
	Automatic residual material detection		△	△
	Transmit / Peripheral surface transformation		○	○
	Thread cutting with constant or variable pitch		○	○
	Tapping with compensating chunk / rigid tapping		○	○
Function	Positioning axes and spindle via synchronized actions		○	○
	Measuring cycles for drilling/milling and turning		△	△





**Whatever You Need
for Milling and Turning
We Offer the Best.**



ROUNDTOP MACHINERY INDUSTRIES CO., LTD.

No.1056, Zhongshan Rd., Shengang Shiang,

Taichung County 429, Taiwan (R.O.C.)

Tel : 886-4-2562-4721

Fax: 886-4-2561-3886

<http://www.johnford.com.tw>

E-mail: johnford@johnford.com.tw