

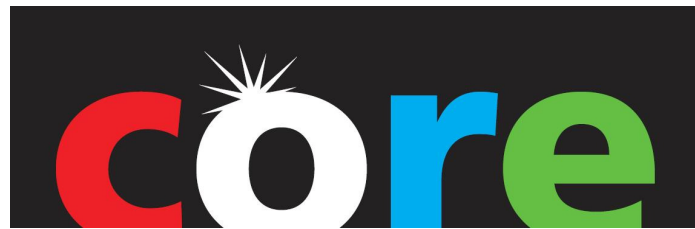

## USER MANUAL



CORE Lighting Ltd

# Point 20

## LiPo Battery Wireless Uplight



## Change History

<b>Ver.</b>	<b>Released</b>	<b>Comments</b>
0_1	22 Sep 10	
1_0	14 Nov 10	Full Production Release
2_0	9 Oct 11	Changes to menu and charging regime

## Contents

1.	Technical Features .....	1
1.1.	LIGHT HEAD .....	1
1.2.	POWER SOURCE & CHARGING .....	1
1.3.	USER CONTROL .....	2
1.4.	WIRELESS INTERFACE .....	2
1.5.	MECHANICAL .....	2
2.	LIGHT HEAD .....	3
2.1.	LIGHT HEAD .....	3
2.2.	OPTICS .....	3
2.3.	LED COLOUR PERFORMANCE & LIFESPAN .....	3
3.	POWER SOURCE & CHARGING .....	4
3.1.	Battery .....	4
3.2.	Power Supply Unit (PSU) .....	4
3.3.	Battery Charging & Discharging .....	4
	CHARGING .....	4
	DISCHARGING & LED Modes .....	5
	LIFESPAN .....	5
3.4.	Battery Temperature .....	6
4.	USER INTERFACE & MENU OPTIONS .....	7
4.1.	On/Off .....	7
4.2.	MODE .....	7
4.2.1.	MODE SELF .....	7
	SELF COLOUR Option .....	7
	SELF CYCLE Option .....	8
4.2.2.	MODE MSTR .....	8
4.2.3.	MODE SLV .....	8
4.3.	Brightness Control “BRI%” and LED “NORM” to “LONG LIFE” .....	9
4.4.	“BAT” Battery status Mode .....	9
4.5.	TOOLS .....	10
4.5.2.	MSTR RSET .....	10
4.5.3.	DIAGnostics .....	10
4.5.4.	SET LOCK .....	10
4.5.5.	SET DISP .....	10
4.5.6.	SET PIN .....	11
4.5.7.	SET WDMX .....	11
4.6.	WIFI Status .....	11
4.7.	ADDR DMX Address .....	11

5. WIRELESS INTERFACES.....	12
5.1. W-DMX Receive .....	12
5.2. W-DMX Transmit.....	12
5.3. WiFi Control .....	12
6. MECHANICAL.....	14
6.1. Dimensions.....	14
6.2. Antenna.....	14
6.3. Locking .....	14
7. Warranty .....	15
8. Compliance Information .....	16
8.1. System Compliance.....	16
8.2. FCC & Industry Canada Statement for Radio Compliance .....	16
8.2.1. WiFi .....	16
8.2.2. W-DMX Transmitter & Receiver .....	16
8.3. WEEE & RoHS Statement .....	17
ANNEX 1 – Menu Structure.....	18

**Please read this entire manual before using the equipment. Please keep the manual in a safe place so you can refer to it in the future.**

## **Safety:**

**Connection, installation and mounting of this equipment must be performed in accordance with all local, regional and national safety codes and regulations.**

**Note: Restrictions apply to transporting this equipment on aircraft due to the lithium polymer batteries having capacity greater than 100Wh. Please consult IATA Packing Instructions 967 and CORE Lighting Ltd for further information.**

## 1. Technical Features

- **Highly efficient RGB + White LEDs producing 2100 lumen output**
- **Ideal for uplighting, colour-wash or high lighting applications**
- **Minimal maintenance during rental use – rugged and intuitive**
- **Sealed to IP65 for indoor and exterior use**
- **16-20h battery life exceeding 8h for most applications**
- **Higher capacity battery upgrade 22Ah lasting more than 12h**
- **Attractive full white with shades of off-white**
- **Full recharge approximately 3 hours from flat (LiPo Technology)**
- **Wireless DMX control with master/slave upgrade**
- **WiFi remote control using most WiFi enabled mobile devices with browser**
- **Intuitive & simple operation – designed for repeated rental**
- **Removable polished steel light shroud or custom colour**

### 1.1.LIGHT HEAD

- RGBW Colour Mixing Head using Cree and Seoul Semiconductor high-brightness LED chips
- Strongly saturated colours, mixed using optic lenses with uniform colour rendering
- LED Lumen Output 2100lm matching market-leading mains-powered units
- More than 4.2Bn colour shades, including hues of white, by using 4-colour channels
- Ability to replicate warm & cool colour temperatures of white light
- Standard 12° beam angle. Simple optic replacement with beam angles 30°, & 60° (medium & wide angles). Others available 20°, 40°, 50°, 80° plus oval diffusers
- Head swivels vertically +/- 45° to allow fine adjustment of beam direction
- Thermally designed for LED Lifespan > 50,000 hours (6 years if permanently switched on)

### 1.2. POWER SOURCE & CHARGING

- Two power options of mains or battery power
- Built-in power supply unit. Input range 100-240VAC 50/60Hz
- Base “kettle” connector for power within flight case or with unit sitting on an external base
- Battery type 14Ah Lithium Polymer (LiPo) with upgrade to higher density 22Ah LiPo pack
- Continuous battery operation on dropout of mains supply
- Ability to operate the unit and charge battery simultaneously
- Smart built-in charger to >95% in 3 hrs (14Ah) or 4hrs (22Ah). Voltage & current monitoring prevents over-charging
- Battery compartment temperature monitored with automatic thermal cut-out
- Deep discharge of battery monitored and prevented using smart relay control
- Battery built-in protection circuit prevents over-discharge of the battery cells
- Battery operating temperature capability of -20 to +50degC

### **1.3.USER CONTROL**

- Control from Wireless DMX (WDMX – Wireless Solutions), keypad or upgrade to WiFi interface
- Onboard control with LED displays visible in dark or bright sunlight  
enabling control of all functions including internal colour and fade sequences
- Simple intuitive controls. Helpful for untrained staff.
- Set of pre-programmed colour & fade sequences.
- Upgradeable setup from any device with WiFi and web browser (eg mobile, iPhone, laptop or PDA). (Note due to 'Ad-Hoc' limitations of certain mobiles this facility may be blocked)
- Password security protection of interfaces from unauthorised access
- Simple built-in diagnostic routines to improve turnaround time in the warehouse environment

### **1.4.WIRELESS INTERFACE**

- Each light responds to wireless W-DMX commands as a slave
- Built-in W-DMX antenna within the head - connection of slave units to a lighting desk or a POINT20/30 unit with Master capability
- Upgradeable W-DMX Master will control a set of slave lights as a stand-alone light network
- Upgrade to WiFi (802.11b/g) interface to set up individual lights
- WiFi access controller within the unit acts as a web server accessed with an individual IP address
- All wireless capabilities are internally integrated, not external add-ons

### **1.5.MECHANICAL**

- Aluminium fabricated housing with black powdercoat finish.
- Replaceable stainless steel shroud – painted spares options available in white or other user-specified RAL colours
- Stable base unit for uneven surfaces
- IP Rating 65 (Totally protected against dust and low pressure water jets from any direction)
- W-DMX antenna built into top LED electronics board
- Securing hole on top and bottom plates allow padlock to be inserted for security
- Weight approx 6.5Kg.
- Dimensions 328mm height x 174mm diameter (feet to top of shroud)

## 2. LIGHT HEAD

### 2.1.LIGHT HEAD

The light head may be tilted to any position vertically up to +/-45 degrees for up-lighting or spotlighting. A Nylok nut on each side of the head bridle assembly allows the swivel tension to be adjusted.

### 2.2.OPTICS

The unit is fitted as standard with a clear polycarbonate lens allowing 12 degree beam angle using 7 LED colour-mixing optics. Beam angles of 30° and 60° (medium and wide angle) are available as an upgrade kit to the standard unit. The diffusers are extremely efficient with more than 90% transmission efficiency.

Diffusers are built into the polycarbonate lens in front of the LED mixers allowing them to be changed by removing the 4mm caphead screws around the outside. These screws must always be replaced with similar type to prevent damage to the top plate. **The screws must not be over-tightened as this will damage the polycarbonate lens. When replacing lenses, care must be taken to ensure dirt is removed from the gasket material and head to ensure water tightness.**

Beyond the standard range of diffusers the following beam angles are available by special request:, 20°, 40 & 80°. Elliptical versions are also available (eg 30° x 5°).

### 2.3.LED COLOUR PERFORMANCE & LIFESPAN

Quality of colour is seen as a critical feature that has been built into this unit.

The LED range, the colours within the range and “binning” options have been selected very carefully to provide possibly the best colour saturation available. This extends the extreme colour points available on the colour triangle and therefore extends the number of possible colour combinations.

White LEDs are selected as “neutral white” to maximise its use in combination with the Red, Green, Blue. White can be made warmer by adding red and green combinations, or cooler by adding blue.

Update rate for the LED's is a fast 488Hz. The resolution for colour change is 13bits providing a very smooth dimming curve. This fast combination makes the units capable of lighting in TV work.

The head's thermal design and correct current balancing through LED chains ensures that LED life should exceed 50,000 hours. Significant effort has been made to ensure correct thermal design to achieve this.

## 3. POWER SOURCE & CHARGING

### 3.1. Battery

The battery is a nominal 12 Volt lithium polymer (LiPo) battery pack. The standard pack is 14Ah but an upgrade to 22Ah is also available that increases battery life by approximately 50%.

**Note: Restrictions apply to transporting this equipment on aircraft due to the lithium polymer batteries having capacity greater than 100Wh. Please consult IATA Packing Instructions 967 and CORE Lighting Ltd for further information.**

### 3.2. Power Supply Unit (PSU)

The unit may be operated under battery power or power supplied by placing the unit onto a charging base with the “kettle” connector (externally or within a flight case).

The power input range is 100-240VAC at 50/60Hz so may be used worldwide.

The unit will enter charging mode when the unit is switched off then external power is applied (See Section 3.3).

The electronics switches its power source based on the greater voltage of either power supply or battery, so if the mains power is removed (in a power cut or generator failure) the PSU voltage drops to 0 so the unit will switch over to battery power. This is useful as a backup light on power failure.

### 3.3. Battery Charging & Discharging

#### CHARGING

Simply plug the mains charging base into the wall or place into a flight case on its bottom connector. The unit manages its own charging so it may be left connected to mains permanently. However, the battery specification provides that 95% of charge is maintained over 3 months when power is removed.

Voltage of the battery can be seen in one of the menu options, achieving full charge at approximately 13.8V (at 20°C). This will fall approximately to 12.5-12.8V once the charger has been removed. The charging current can also be monitored (see DIAGNOSTICS menu ‘AN1’) and should be around 5 Amps on full-charge, falling when the battery is near capacity. The charging LED on the keypad (lower right) and LEDs in the head will flash amber whilst initial charging takes place up to around 60% capacity and a “^” symbol will appear in the BATT menu option. Between 60 & 95% capacity the display will turn to solid amber. When the battery is full the charging LED will turn green. If the display LED and head show red, this means the battery is disconnected or over-temperature. Allow to cool down and retry. If the problem persists contact CORE Lighting.



Normal charging achieves >95% of battery level in around 3 hours from empty when “BATT FULL” is displayed in that menu option and the head shows green. The unit continues trickle charging after this point indefinitely. Trickle-charge mode is useful for maintaining charge whilst units are in hire stock. “BATT FULL” is seen when charge current drops below 0.1A (see DIAGnostics menu ‘AN1’).

The power supply can charge the battery and operate the unit simultaneously, although this takes longer to charge as less current can be drawn by the charger from the PSU.

**Note – when charging the head LEDs are disabled and are converted to a charging operation display. Normal operation can be resumed by pressing the “ON” button which will continue operation when power is removed as long as there is sufficient capacity in the battery.**

## **DISCHARGING & LED Modes**

There are three modes of operation: NORMAL, LOW O/P & LONG LIFE selectable on the main menu.

NORMAL mode is 100% LED output. LOW O/P is 80% and LONG LIFE is 50% output (therefore 2 x lifespan).

Discharge lasts in excess of 7 hours in NORMAL LED colour-cycling mode “SLOW RNBW” with the dimmer control at full (BRI% 100). In practice the unit will achieve longer life at normal operating temperatures providing the charging regime is maintained as described above. Life may be extended by reducing the dimmer to, say, 70% which will add 30% to life; or moving to LOW O/P or LONG LIFE Modes.

If full white is used then lifetime will be considerably reduced, although the LEDs produce over 2100 lumens in this mode. Using only the White LED channel (and not RGBW) the unit should last over 15 hours in NORMAL mode with dimmer at maximum. This is around 50% of brightness of full RGBW.

When the battery drops to a particular voltage the low battery red LED is activated permanently on the lower right of the membrane keypad as a warning the battery needs recharging. When the voltage drops further the unit simply switches off. This is to prevent over-discharge as a LiPo battery can go into a non-recoverable mode in such a case. Smart monitoring of both the charge and discharge cycles therefore helps to preserve the lifetime of the battery.

## **LIFESPAN**

**Once discharged it is important for the battery to be recharged as soon as possible to prevent long term damage to the battery.** The battery should be capable of more than 400 recharge cycles if fully discharged then fully recharged straight away to more than 90% battery capacity. Lighter use will preserve battery life further (over 1000 cycles at 50% repeated discharge).

### 3.4. Battery Temperature

This may be monitored in the “BATT” menu option and is monitored by software so that excessive heat shuts down the unit over-charging. A steady flashing red charge status LED indicates this has occurred, meaning the battery temperature is over 45 deg.

The battery is capable of operation -20 to +50 deg.

## 4. USER INTERFACE & MENU OPTIONS

PLEASE REFER TO ANNEX 1 MENU STRUCTURE FOR DETAIL ON HOW TO STEP THROUGH MENU OPTIONS.

### 4.1.On/Off

The unit is switched **ON**, either on mains or battery power, by pressing the silver button on the top plate of the unit. If the unit is in Charge Mode, pressing this button will bring the unit out of charge mode and apply power to the head, where full unit operation is resumed.

The unit is switched **OFF** – but only disconnected from the battery - by pressing the RED switch on top of the unit. **On mains power this red button will not switch off the unit.**

To switch off mains power the power cord should be disconnected at the wall.

After the unit is switched off, when reactivated with the “ON” switch the lighting unit will retain its previous state prior to shutdown.

### 4.2.MODE

The unit enters this menu option upon switch-on. Three modes are available on the unit:

- Self-functioning using the on-board keypad and display or upgradeable to WiFi.
- Master unit controlling others (Wireless DMX) [Wireless is an upgrade option].
- Slave unit controlled by a Master unit (Wireless DMX) or a lighting desk.

#### 4.2.1. MODE SELF

Two options are available within this mode: “SELF COLR” and “SELF CYCL”. These functions are also available through WiFi on upgraded units.

“MODE SELF” is for self-contained units not needing to be linked to other units or lighting desks and is suitable for many applications. In reality if multiple units are adjacent to each other and colour cycling functions are selected then providing they are switched on simultaneously the clock accuracy should maintain their synchronisation closely for a few hours.

***Note the brightness of both options may be controlled using the dimmer (BRI%) function. It will help preserve battery life if lower brightness is selected.***

#### **SELF COLOUR Option**

This allows individual colours to be controlled on the unit menu from values of 0 to 255. This provides around 4.2 billion combinations including easily definable shades of white.

## **SELF CYCLE Option**

This mode sets the unit to cycle through various colours depending on the mode. Provision has been provided for all colour cycling, warm options or cool options and a couple of different speeds.

The most popular is “SLOW RNBW” for a gradually changing colour sequence of all colours, which shows off the true colour depths of the LEDs. “TEST” switches between the four colour chains of LEDs so the individual elements within each colour chain can be seen and checked.

### **4.2.2. MODE MSTR**

This mode is available on the menu but the enabling hardware is available as an upgrade option. It allows the unit to be configured as a MASTER in a DMX universe and eliminates the need for a lighting desk for a simple lighting setup. Other SLAVE units set in MODE SLV will respond to Wireless DMX signals output from this MASTER device. MASTER mode has built-in patterns of lights allowing each SLAVE to replicate the colour changes of the MASTER Unit, thus creating a wider lighting scheme using a network of lights that are synchronised together.

It is possible to set the output of MASTER mode to send via a built-in Wireless Solutions W-DMX transmitter (OUT WDMX) if this option has been purchased.

SLAVE units will need to be connected to the MASTER unit. This can be achieved by selecting the “ADD UNIT” in the MASTER DMX menu. Prior to this the SLAVE unit needs to have its wireless disconnected from any other transmitter by entering “WDMX UNLNK”. This also puts the SLAVE into “hunting” mode where it will seek a new MASTER unit. When the unit comes into contact with a master unit in “ADD UNIT” mode, the two units will automatically pair together after a few seconds. During this process a decimal point will flash quickly in the bottom right corner of the display simultaneously on both Master and Slave units. When this extinguishes and becomes statically “on” then pairing is complete. Any number of slaves can be connected to a single Master unit in this way at the same time by setting all Slaves into “Unlink” mode then adding them with a single “Add Unit” entry on the Master unit.

### **4.2.3. MODE SLV**

SLAVE mode is fitted to every unit as standard and can be configured to work with a Wireless-DMX transmitter.

WirelessDMX uses a module from Swedish firm Wireless Solutions with a built-in antenna within the housing exterior.

## **LINKING & UNLINKING to a Wireless Solutions Transmitter**

The POINT20 needs to be linked to the transmitter being used, which is a simple process. But first the unit needs to be Unlinked from any previous unit it was “paired” with.

In the menu, the “Unlink” function follows from MODE SLV. Pressing enter takes you to a menu showing WDMX ULNK. Press enter at this stage and the unlinking happens (note: it takes 5 seconds or so). After pressing enter, the unit returns to the MODE SLV menu. If you don't want to unlink, then press MENU UP or MENU DOWN and it will take the unit to the MODE menu without unlinking.

When the unit is unlinked, adding it to a Wireless Solutions transmitter box is just a matter of pressing the button on the transmitter box for a brief period (less than 2 seconds). The lamps will pick up after about 5 seconds and the SLAVE will show a decimal point statically illuminated in the display (lower right corner) and also a LINK LED on the transmitter.

### 4.3. Brightness Control “BRI%” and LED “NORM” to “LONG LIFE”

**The overall brightness level setting (NORMAL, LOW O/P or LONG LIFE) sets the overall dimmer for the unit for all SELF operating, SLAVE and MASTER modes (i.e. self or external control). BRI% then allows further control once this is set.**

**NORMAL sets the overall brightness of the unit to 100%.**

**LOW O/P sets overall brightness to 80%**

**LONG LIFE is 50%.**

**NORMAL operating mode should give over 7-8 hours life on a normal colour cycle. This can provide extra brightness for larger illuminations such as architectural building lighting where additional light throw is required. LOW O/P is recommended for normal indoor use where lifespan will be around 20% longer. LONG LIFE can be regarded as a battery preservation mode to gain approximately 50% extra lifetime from a charge.**

BRI% adjusts the brightness as a multiplier of the colour options in “MODE SELF” or “MODE MSTR” and is selected as a percentage 0 to 100. It is a useful tool for conserving battery life also. This should be set to 0 whilst charging to prevent unnecessary drain on the power supply and to optimise charging.

### 4.4. “BAT” Battery status Mode

Two options are available: one showing temperature of the battery compartment used as a failsafe mechanism to prevent damage through over-charging. The second shows battery voltage.

Note the symbol “^” shows battery charging is active. “BATT FULL” shows when this is complete.

## **4.5.TOOLS**

### **4.5.1. SHOW S/N Serial Number**

This is the serial number of the unit (eg “CORE 0216”) and provides the WiFi SSID address based on the unique serial number (its WiFi unique identity). The number is set at the factory and is unique to each unit.

### **4.5.2. MSTR RSET**

Master Reset provides a facility for rental firms to reset all parameters to known settings. These settings are shown in Annex1 on the User Interface Map.

### **4.5.3. DIAGnostics**

Allows the factory to check various functions that will be used in the self-test sequence. The following are worthy of note:

AN1 – Battery Current showing either charging current or useage current.

AN3 – Battery Temperature, also available in “BAT” menu

### **4.5.4. SET LOCK**

If the LOCK ON function is selected then the data entry to the system is locked to prevent tampering. The full menu can still be seen using key presses but no changes can be made. LOCK ON is retained if the unit is switched off then back on again.

To regain control of the unit the Unlock function should be selected by selecting “LOCK OFF” and pressing Enter. The PIN Code to unlock the unit is set at the factory to “2673” – characters represented as “CORE” on a standard telephone keypad.

This may be changed by entering the SET PIN menu option (Section 4.5.6).

### **4.5.5. SET DISP**

The keyboard display is extinguished after a fixed period of keypad inactivity in order to eliminate glare. This function sets the time delay from last key operation between 30 and 300 seconds before the display switches off. A reminder point is left switched on (bottom right of left display), as a warning the unit is switched on when the LED head brightness is turned to zero and is running on battery power. This reduces the likelihood of the unit being left on battery power indefinitely without any indication.

#### 4.5.6. SET PIN

The default Personal Identification Number (PIN) to unlock the unit after it has been placed in “LOCK” mode is “2673”. The PIN number may be altered using this function by entering the old PIN number for security then entering the new PIN number successfully twice. The +/- keys are used to make the adjustment on each character and the enter key is used to jump from one character to the next. If unsuccessful the screen will say “SET FAIL”, otherwise “SET PASS”.

**If the PIN number is forgotten then the value for AN16 in the Diagnostics menu should be reported to CORE Lighting, without switching the unit off, who will explain the PIN unlocking procedure.**

#### 4.5.7. SET WDMX

**\*This is a factory setting mode to adjust the internal operation of the Wireless DMX module and should not be used unless under technical supervision from CORE Lighting or a technically competent distributor.\***

#### 4.6. WIFI Status

WiFi (where fitted as an upgrade) may be activated by selecting “WiFi ON” in the menu and pressing the “enter” key. When the counter reaches “3” the unit is ready to receive WiFi requests. The display will remain in this state and cannot be adjusted from this point using the keypad except for switching WiFi off.

Switching off is a matter of entering “WiFi OFF” then “enter”. **Note the importance of hitting the “enter” key.**

#### 4.7. ADDR DMX Address

This is the address channel for Wireless DMX.

Channels 1 to 506 may be selected, although from the selected channel the subsequent 5 channels are then allocated as below.

Each 5 steps represents the following order of channels:

RED  
GREEN  
BLUE  
WHITE  
BRIGHTNESS

Values of 0 to 255 may be input to each of those channels.

**NOTE –A VALUE MUST BE USED FOR BRIGHTNESS, OTHERWISE NO LED OUTPUT WILL BE OBTAINED FROM ANY OF THE COLOURS (Brightness x Colour Value = light output).**

## 5. WIRELESS INTERFACES

The Point20 Unit uses Wireless Solutions W-DMX protocol for receiving and sending wireless DMX data. There are 512 channels of which the unit uses five. WiFi Control is also available to replace local control from the keypad with remote control from devices with a WiFi interface and browser software built-in.

### 5.1. W-DMX Receive

A W-DMX Receiver is built into every unit thus enabling it to operate in SLAVE mode. See Section 4.2.3 for operational details.

When linked to a Wireless Solutions transmitter or CORE POINT MASTER unit (an upgrade option) the units have a static “link” LED in the bottom right hand side of the display to show that a W-DMX connection has been made. When hunting for a transmitter this will be extinguished but will flash quickly when detected by a transmitter hunting for receivers. Once the transmit and receive devices establish the connection the LED stops flashing showing they are now linked.

### 5.2. W-DMX Transmit

A W-DMX Transmitter (MASTER Mode) is available as an upgrade option within the unit. See Section 4.2.2 for details on how to operate the unit in this mode.

### 5.3. WiFi Control

WiFi control is an upgrade option and is suitable for use with devices allowing ad-hoc networking (note this excludes RIM Blackberry and Android devices at the time of writing). The WiFi module within the unit acts as a web server and may be accessed by finding the unit in the WiFi networks as “CORE XXXX” from the client device such as PC, PDA or mobile phone with WiFi and browser (this is called the SSID). The web server facility allows many complex functions to be achieved not possible on the keypad, such as colour-picking static colours using a colour chart. Diagnostic information is also available from the unit. If the W-DMX Transmit upgrade option is fitted then it is possible to use WiFi to control the MASTER unit which can then control many SLAVE units. This is useful when setting up a lighting scheme.

Select the unit showing the correct CORE SSID in WiFi networks on the host device.

Enter the WEP password key which is “w2673” Or “w” followed by “CORE” on a standard telephone keypad.



Once logged into the unit, select the web browser and enter into the URL address bar 'http://169.254.100.1/'. This should bring up a number of tabs and a logical workflow within each tab.

In addition to the above procedure, on an Apple iPhone or iPod Touch the WiFi connection for the CORE device needs to be set with a Static IP address and settings as follows – by clicking on the right arrow on the relevant WiFi connection, clicking the “Static” tab and entering the settings as follows:

IP Address: **169.254.100.2 \*\***

Subnet Mask: 255.255.0.0

Router: 169.254.100.1 (This is the address for the lighting unit acting as a web server)

DNS: no settings to be entered

**\*\* each device on the wireless network needs to have a different address from 169.254.100.2 to 169.254.100.255 otherwise the network will crash**

## 6. MECHANICAL

### 6.1. Dimensions

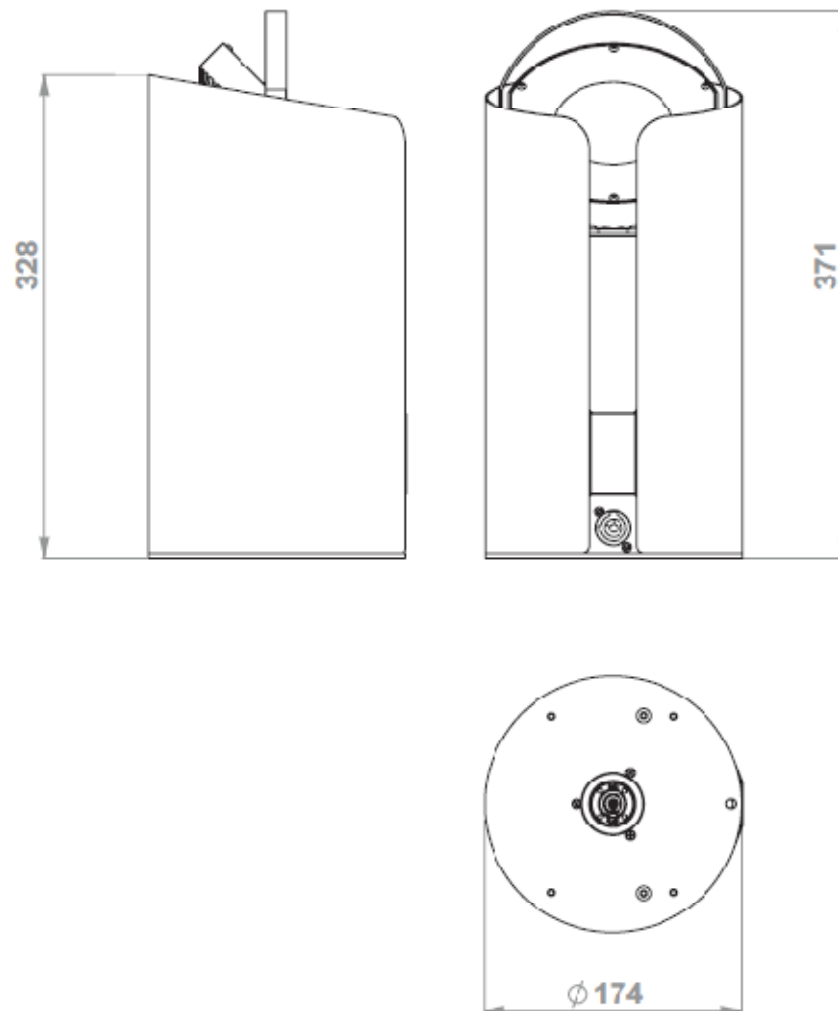

### 6.2. Antenna

The antenna is a high-gain type similar in performance to the Wireless Solutions W-DMX 2dB standard antenna according to testing. This antenna is now fitted to all CORE POINT units.

### 6.3. Locking

The unit may be locked to a nearby object by passing a locking wire or padlock through the locking holes in the top or bottom plates.

## 7. Warranty

CORE Lighting Limited (CORE Lighting) warrants this product to be free from defects in materials and workmanship (subject to the terms set forth below).

CORE Lighting will repair or replace (at CORE Lighting's option) this product or any defective parts in this product. The standard warranty period is 24 months from date of purchase although this period may vary from country to country. If in doubt consult your dealer and ensure that you retain proof of purchase.

To obtain warranty service, please contact the CORE Lighting authorised dealer from which you purchased this product. If your dealer is not equipped to perform the repair of your CORE Lighting product, it can be returned directly to CORE Lighting, with carriage being paid at your own expense. You will need to ship this product in either its original packaging or packaging affording an equal degree of protection. Providing the product is found to be faulty, CORE Lighting will pay for return carriage.

Proof of purchase in the form of a bill of sale or receipted invoice, which is evidence that this product is within the warranty period, must be presented to obtain warranty service.

This Warranty is invalid if (a) the factory-applied serial number has been altered or removed from this product or (b) this product was not purchased from a CORE Lighting authorised dealer.

This Warranty does not cover cosmetic damage or damage due to acts of God, accident, misuse, abuse, negligence, commercial use, or modification of, or to any part of, the product. This Warranty does not cover damage due to improper operation, maintenance or installation, or attempted repair by anyone other than CORE Lighting or a CORE Lighting dealer, or authorised service agent which is authorised to do CORE Lighting warranty work. Any unauthorised repairs will void this Warranty. This Warranty does not cover products sold AS IS or WITH ALL FAULTS.

REPAIRS OR REPLACEMENTS AS PROVIDED UNDER THIS WARRANTY ARE THE EXCLUSIVE REMEDY OF THE CONSUMER. CORE LIGHTING SHALL NOT BE LIABLE FOR ANY INCIDENTAL OR CONSEQUENTIAL DAMAGES FOR BREACH OF ANY EXPRESS OR IMPLIED WARRANTY IN THIS PRODUCT. EXCEPT TO THE EXTENT PROHIBITED BY LAW, THIS WARRANTY IS EXCLUSIVE AND IN LIEU OF ALL OTHER EXPRESS AND IMPLIED WARRANTIES WHATSOEVER INCLUDING, BUT NOT LIMITED TO, THE WARRANTY OF MERCHANTABILITY AND FITNESS FOR A PRACTICAL PURPOSE.

Some countries and US states do not allow the exclusion or limitation of incidental or consequential damages or implied warranties so the above exclusions may not apply to you. This Warranty gives you specific legal rights, and you may have other statutory rights, which vary from state to state or country to country.

For any service, in or out of warranty, please contact your dealer.

## 8. Compliance Information



### 8.1. System Compliance

CORE Lighting Limited declares that this product conforms to the specifications listed in this manual, following the provisions of the European R&TTE directive 1999/5/EC:

Restrictions on Hazardous Substances (RoHS) (2002/95/CE)  
Electromagnetic Compatibility (2004/108/EC).  
Safety (EN 60950)  
Technical requirements for radio equipment. (EN 300 328)

*CAUTION—This equipment is intended to be used in all EU and EFTA countries.  
Outdoor use may be restricted to certain frequencies and/or may require a license for operation.  
Contact local Authority for procedure to follow.*

### 8.2. FCC & Industry Canada Statement for Radio Compliance

#### 8.2.1. WiFi

A CORE POINT20 unit which has been upgraded with WiFi functionality contains Transmitter Module  
FCC ID: P1405W.

This device complies with part 15 of the FCC Rules. Operation is subject to the following two conditions: (1) This device may not cause harmful interference, and (2) this device must accept any interference received, including interference that may cause undesired operation.

Changes or modifications not expressly approved by the party responsible for compliance could void the user's authority to operate the equipment.

**The antennas for this transmitter must be installed to provide a separation distance of at least 20 cm from all persons** and must not be co-located or operating in conjunction with any other antenna or transmitter.

#### 8.2.2. W-DMX Transmitter & Receiver

We,

**CORE Lighting Limited**  
**Prindion House**  
**Kingsmill Lane**  
**Painswick**  
**Gloucestershire GL6 6SA**

declare under our sole responsibility that the product

FCC ID: UQT-WDMXOEMPCBF  
Model: W-DMX OEM PCB F

complies with Part 15 of the FCC Rules.

Operation is subject to the following two conditions:

- (1) this device may not cause harmful interference, and
- (2) this device must accept any interference received, including interference that may cause undesired operation.

To assure continued compliance, any changes or modifications not expressly approved by the party responsible for compliance could void the user's authority to operate this equipment.

**NOTE:** This equipment has been tested and found to comply with the limits for a Class B digital device, pursuant to Part 15 of the FCC Rules. These limits are designed to provide reasonable protection against harmful interference in a residential installation.

This equipment generates, uses, and can radiate radio frequency energy and, if not installed and used in accordance with the instructions, may cause harmful interference to radio communications.

However, there is no guarantee that interference will not occur in a particular installation. If this equipment does cause harmful interference to radio or television reception, which can be determined by turning the equipment off and on, the user is encouraged to try and correct the interference by one or more of the following measures:

- Reorient or locate the receiving antenna.
- Increase the separation between the equipment and receiver.
- Connect the equipment into an outlet on a circuit different from that to which the receiver is connected.
- Consult the dealer or an experienced radio/TV technician for help.

### **RF Exposure Warning for North America, and Australia**

**Warning!** To meet FCC and other national safety guidelines for RF exposure, **the antennas for this device must be installed to ensure a minimum separation distance of 20cm (7.9 in.) from persons.**

## **8.3. WEEE & RoHS Statement**



The European Directive 2002/96/EC on Waste Electrical and Electronic Equipment (WEEE), requires that products must not be disposed of the normal unsorted municipal waste stream. Appliances must be collected separately in order to optimise the recovery and recycling of the materials they contain and reduce the impact on human health and the environment.

The consumer must contact their local authority or retailer for information concerning disposal of their products.

CORE Lighting provides a take-back facility for batteries used within CORE Lighting products, although the expense for transport remains the liability of the consumer. Please contact CORE Lighting directly if this service is required.

## **ANNEX 1 – Menu Structure**

See attached sheet