

F1. SOLENDID VALVE ASSY.

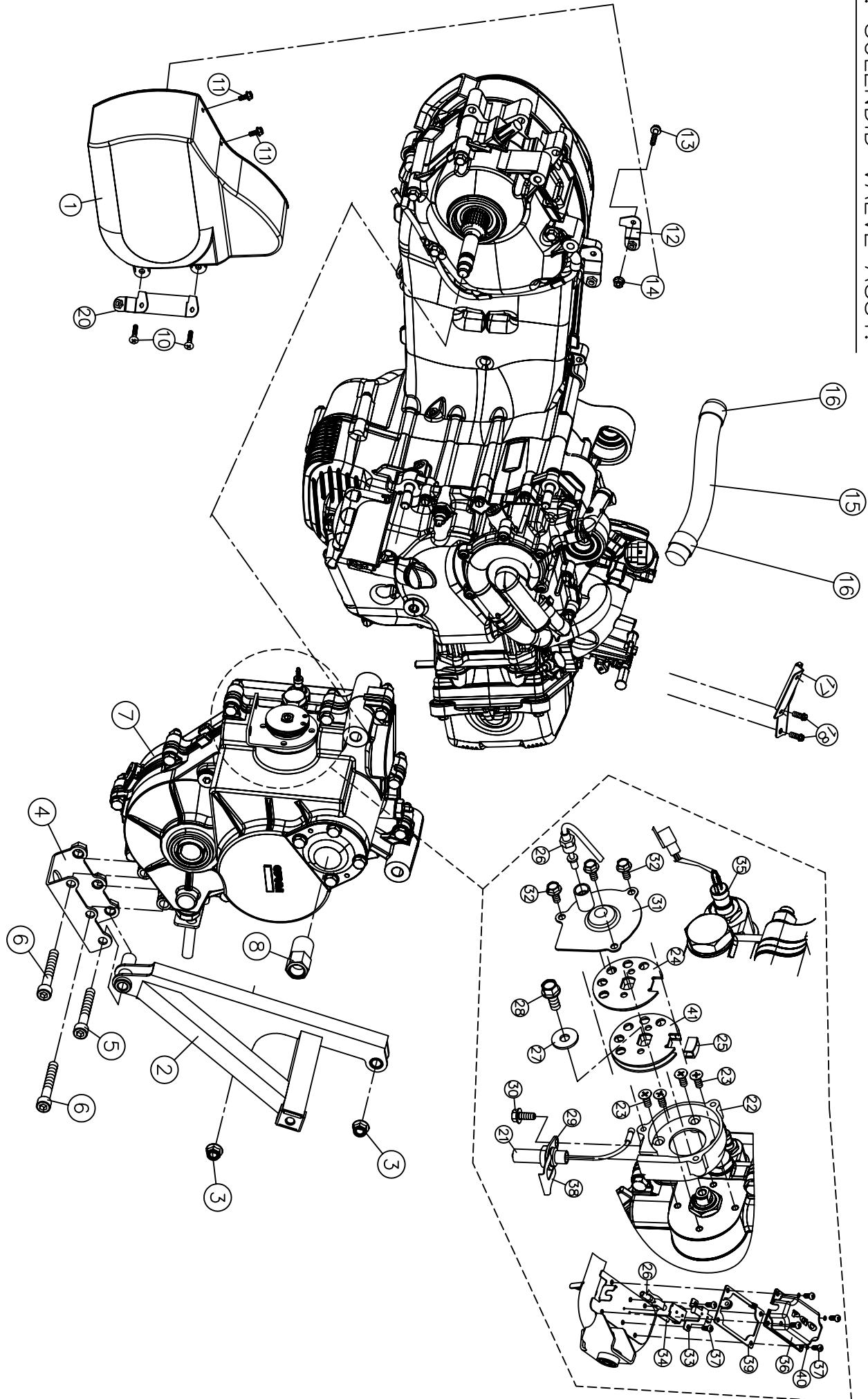

F1. SOLENDID VALVE ASSY.

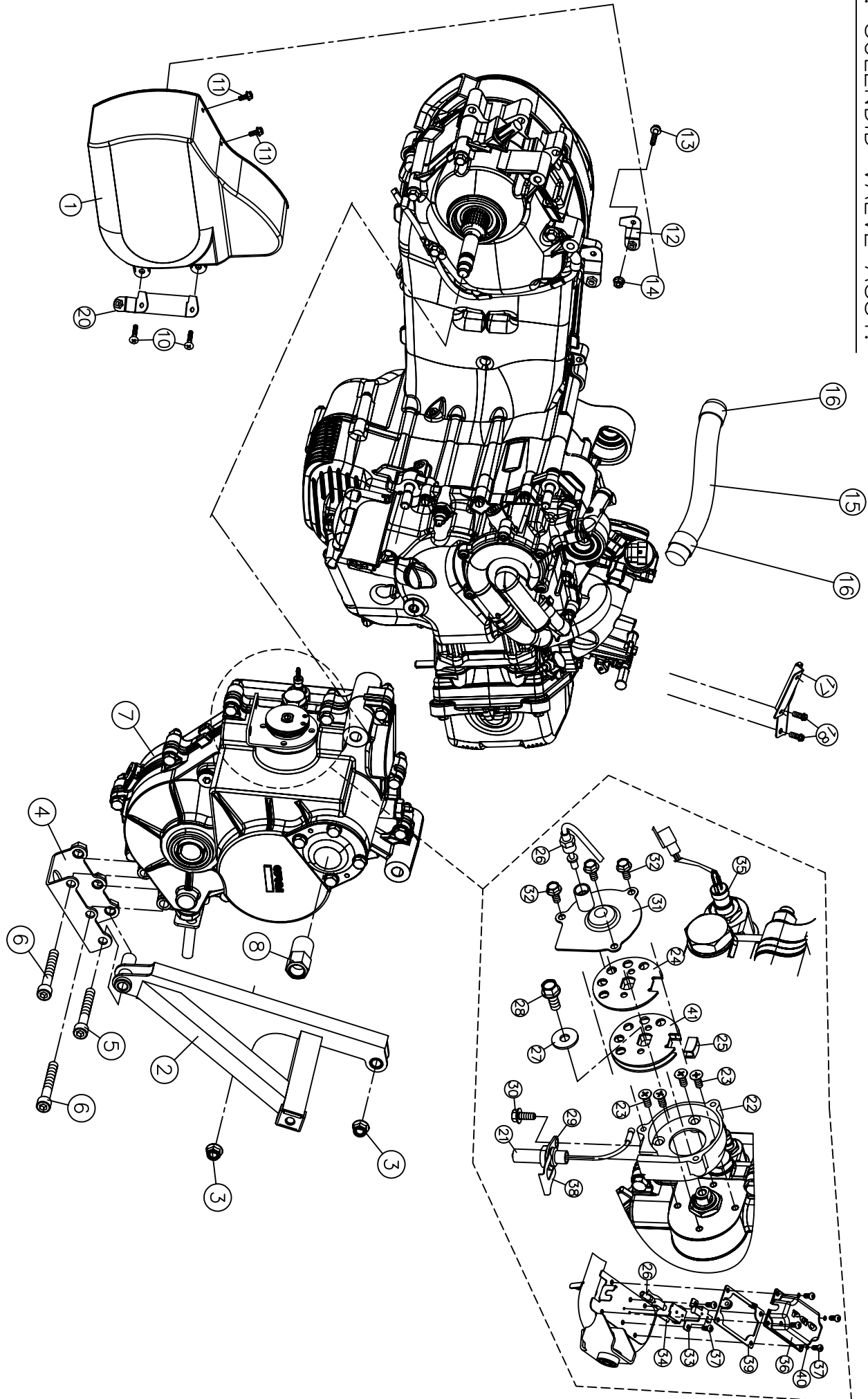

F2. ENGINE HANGER / MUFFLER

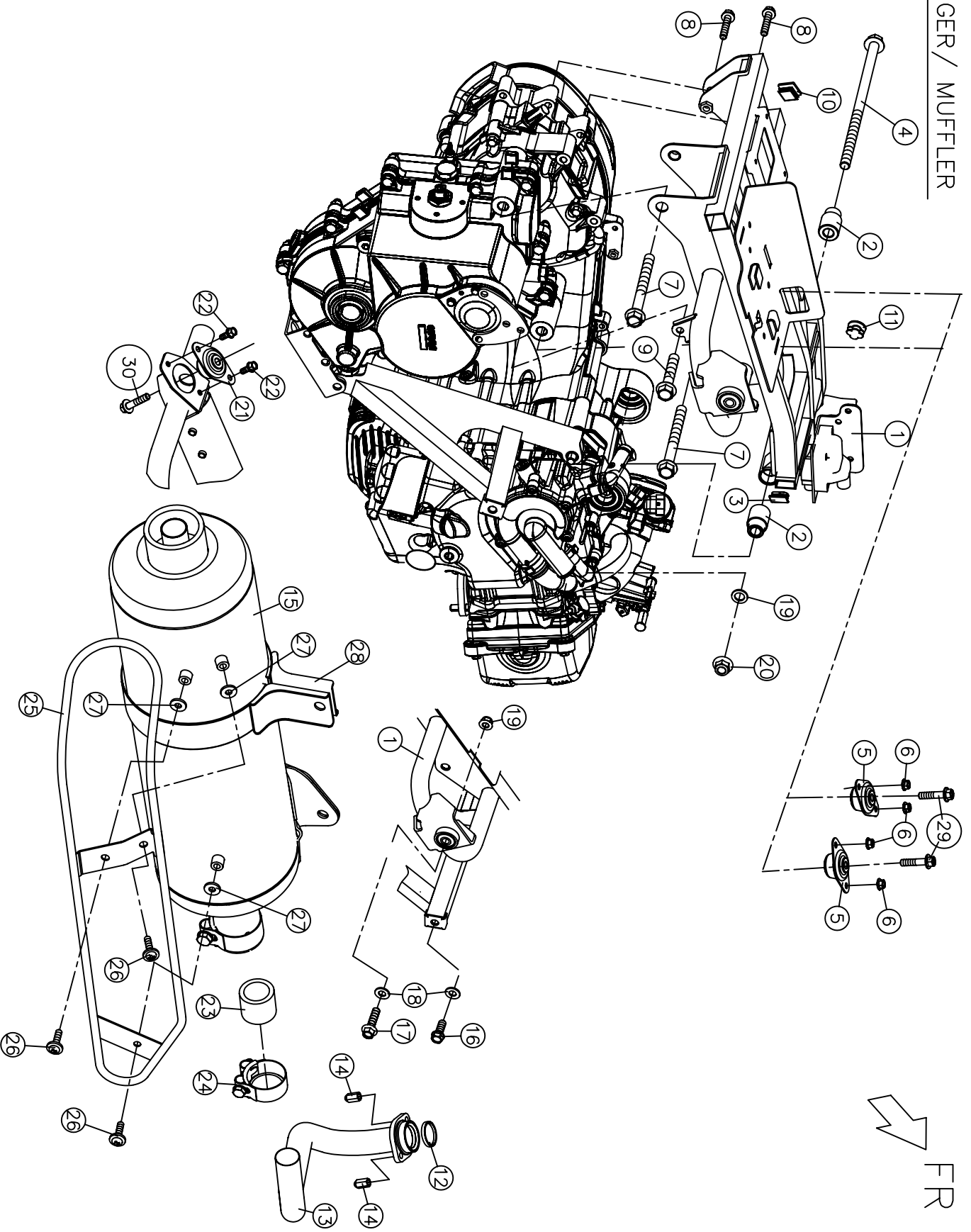

F3. PLASTIC COVERS

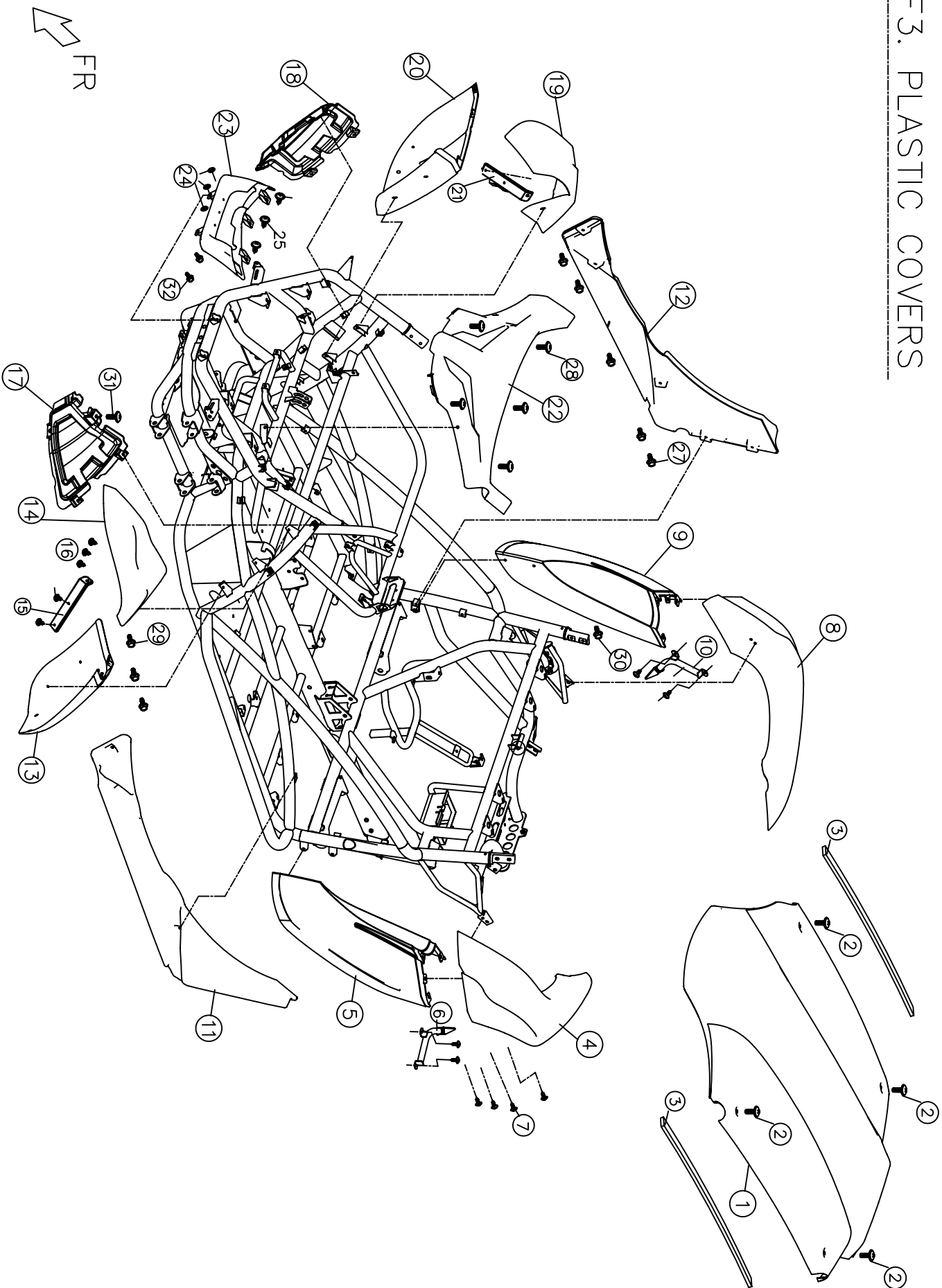

F3. PLASTIC COVERS

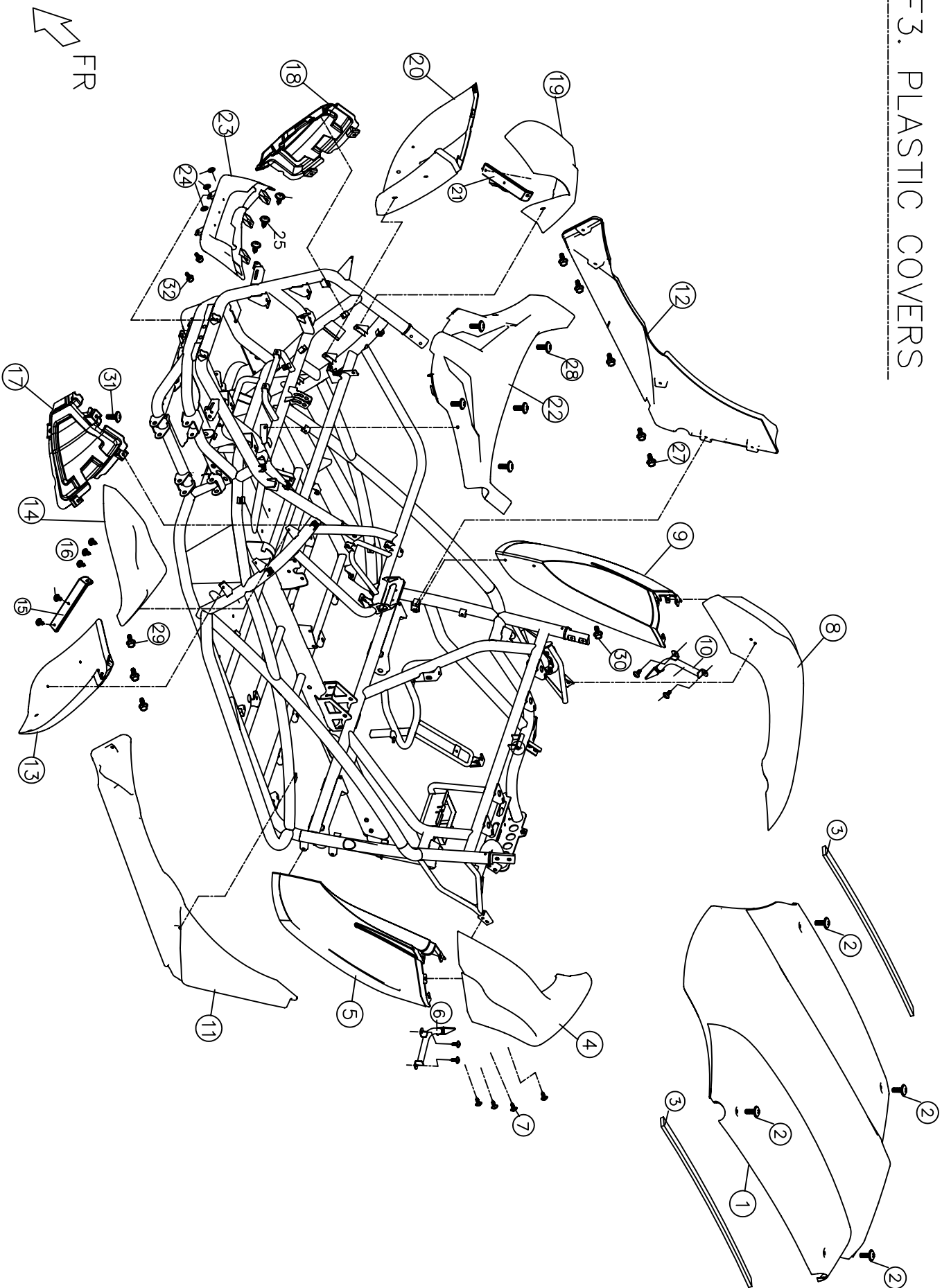

F4. FRAMES

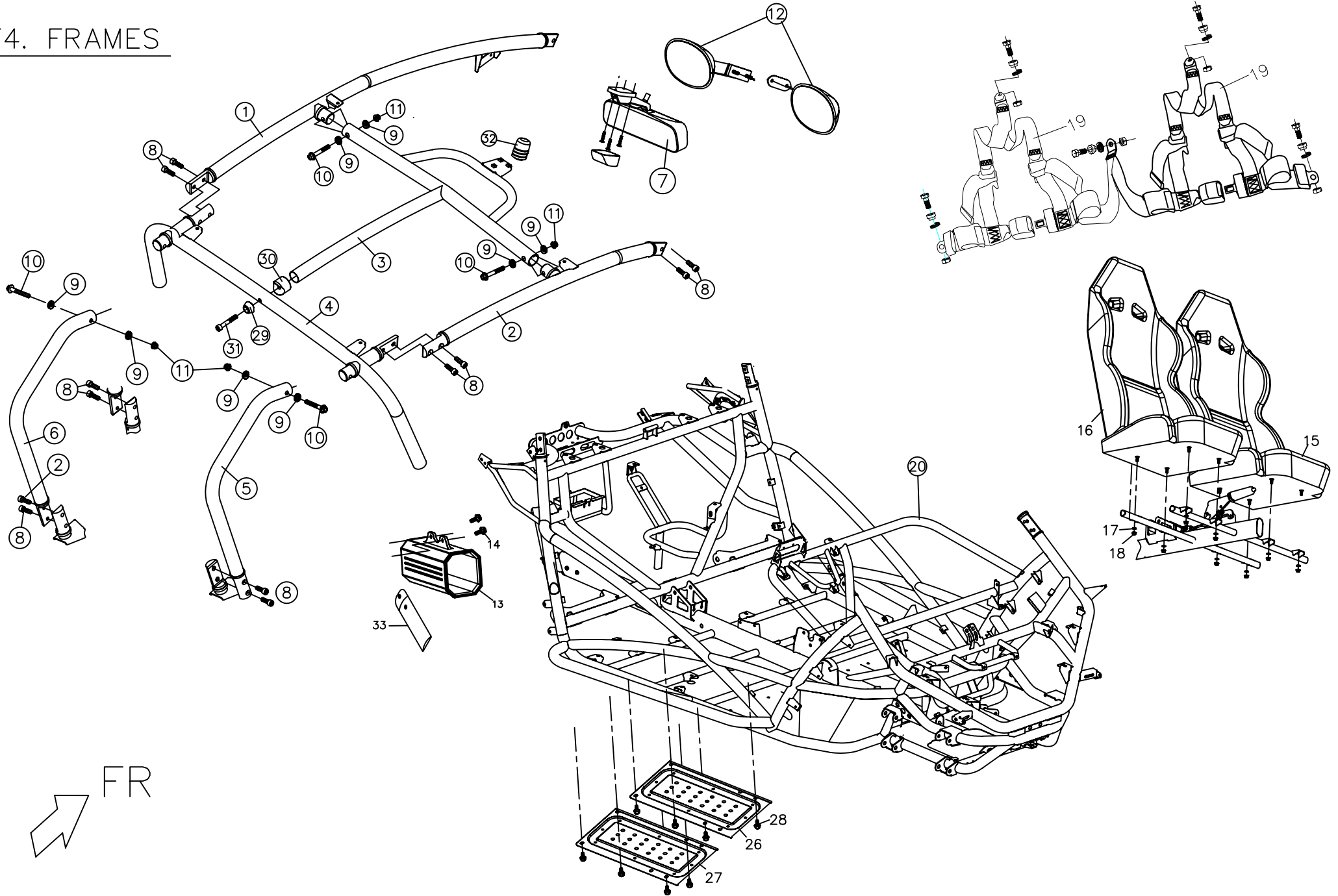

F4. FRAMES

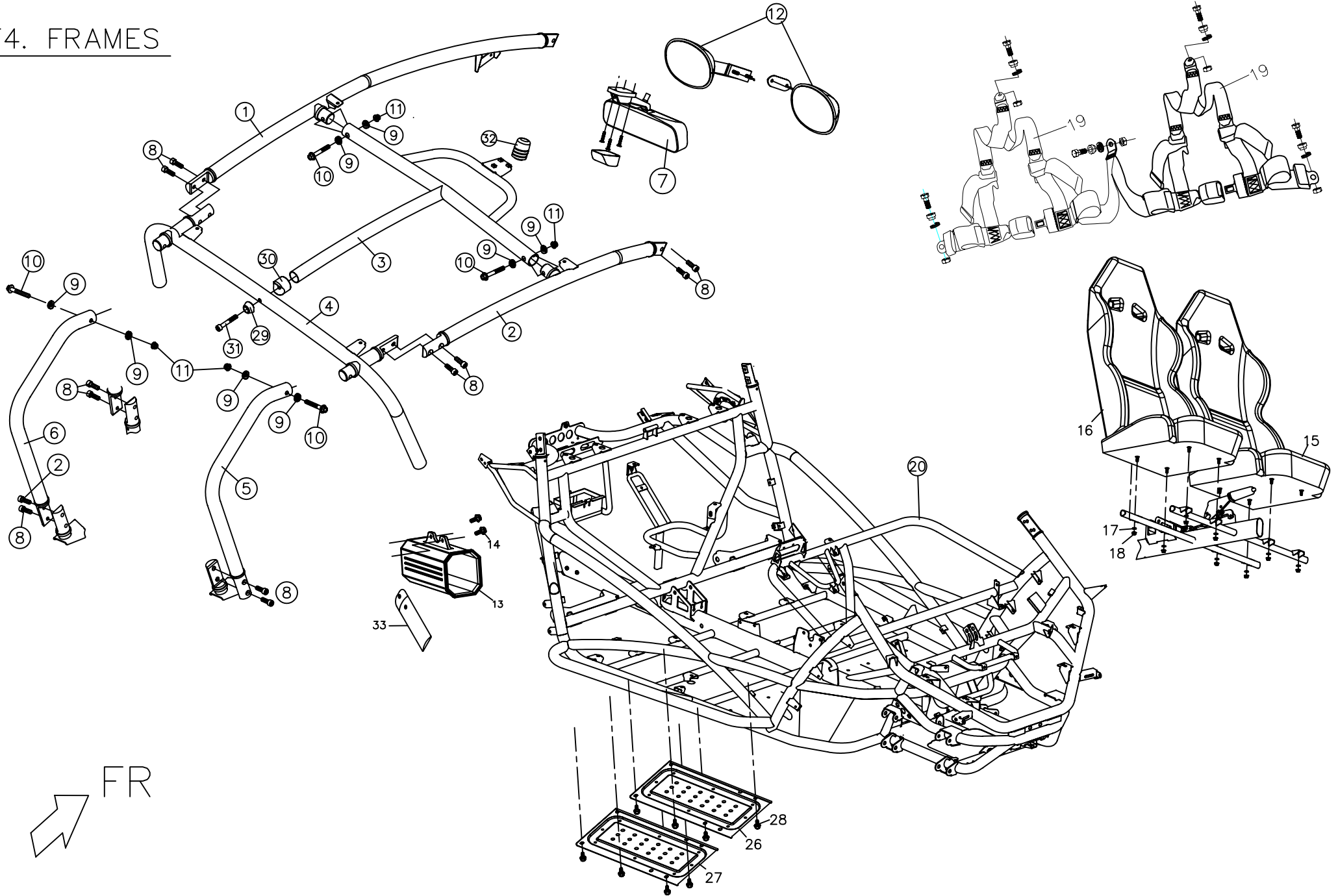

F5. WHEELS

FR

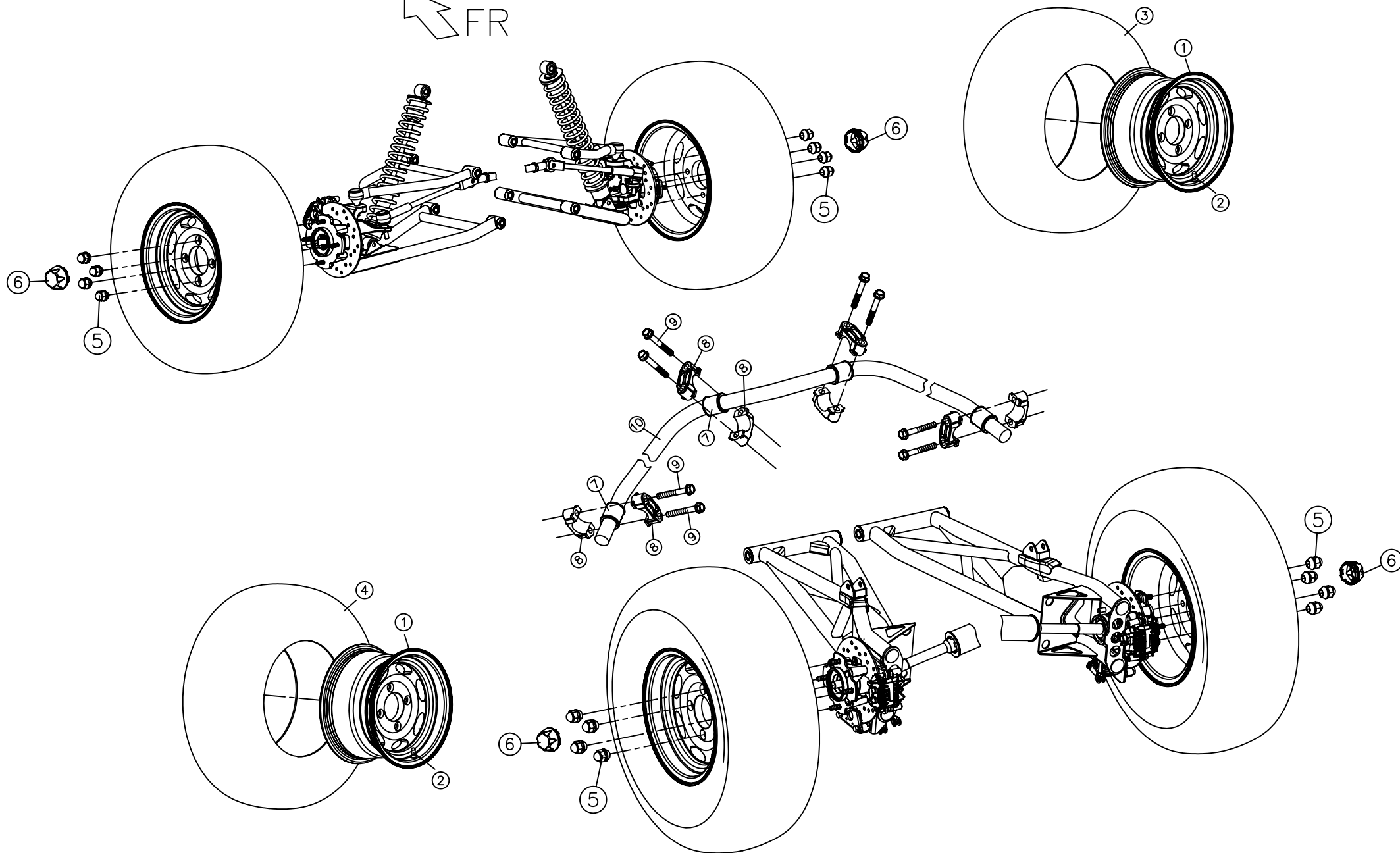

F6. CONTROL CABLES

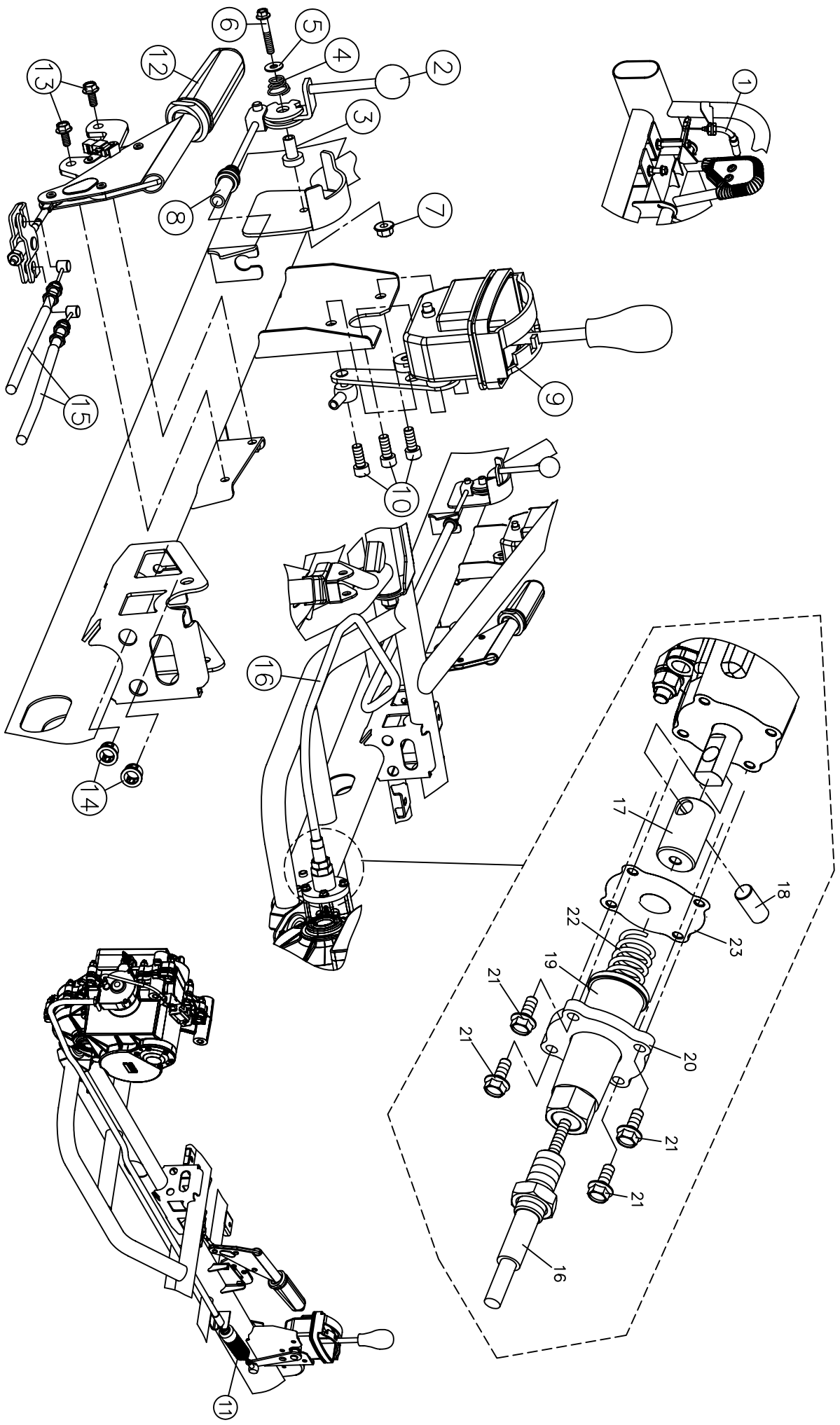

F7. BRAKE SYSTEM

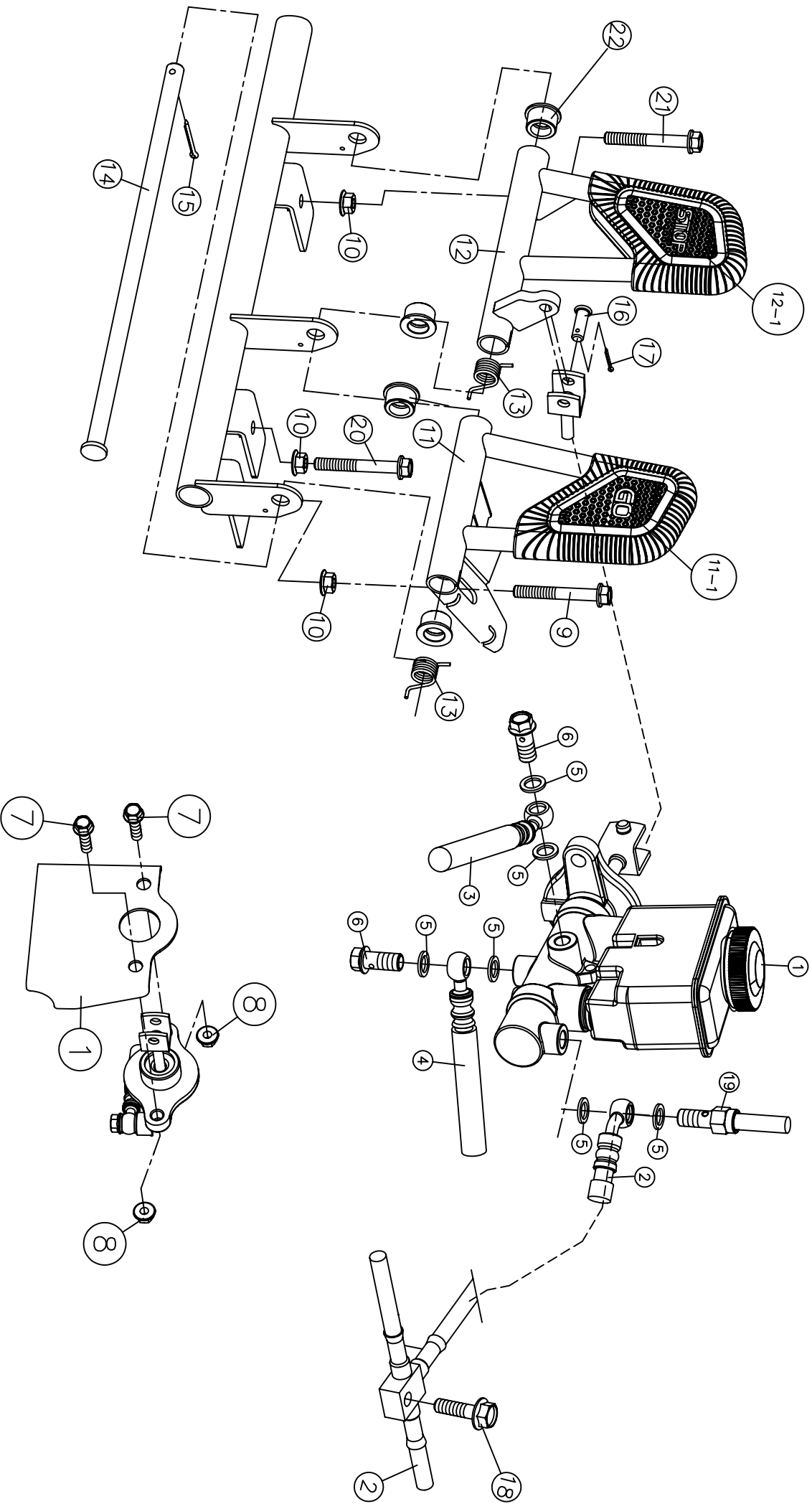

FR

F8. STEERING MECHANISM

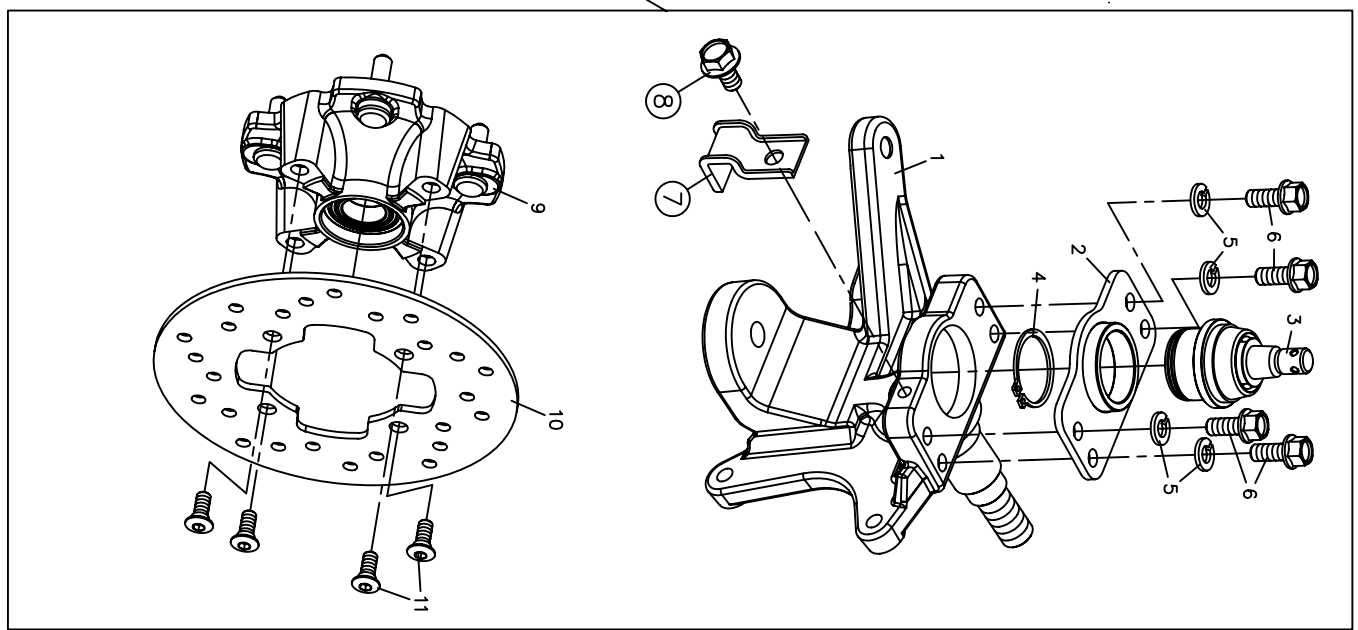
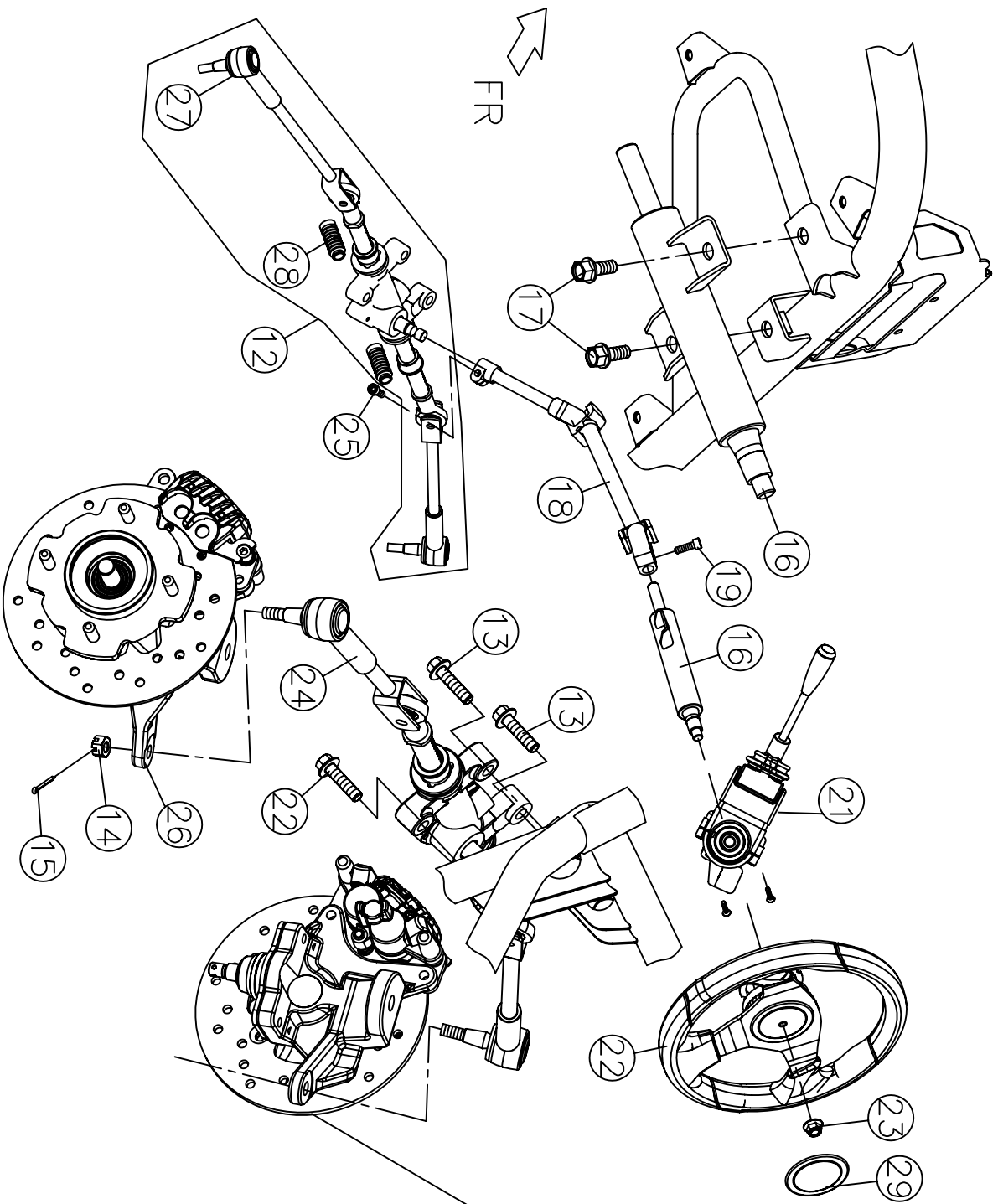

F9. SWING A ARMS

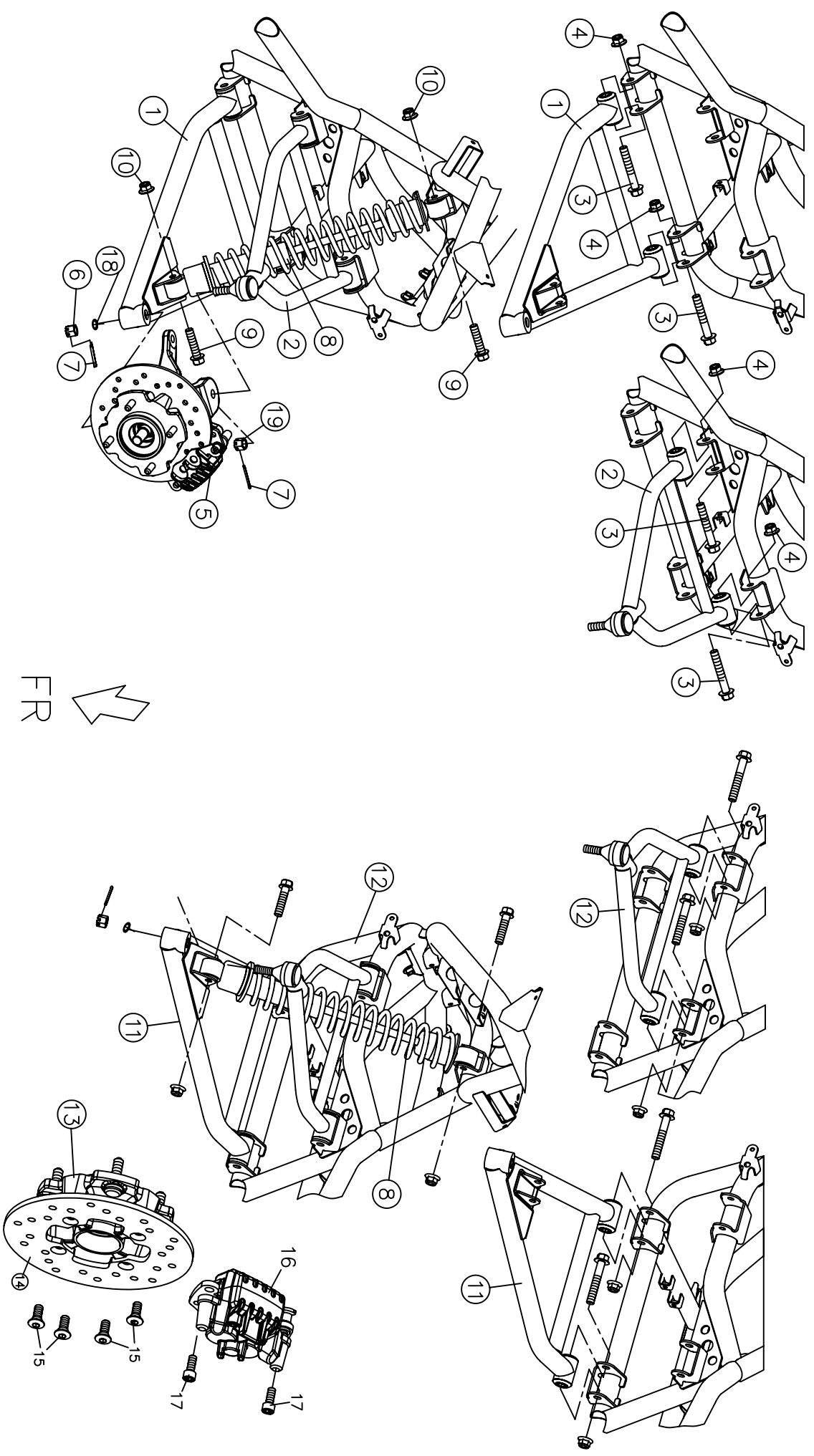

F10. DRIVING SHAFT, ABSORBER

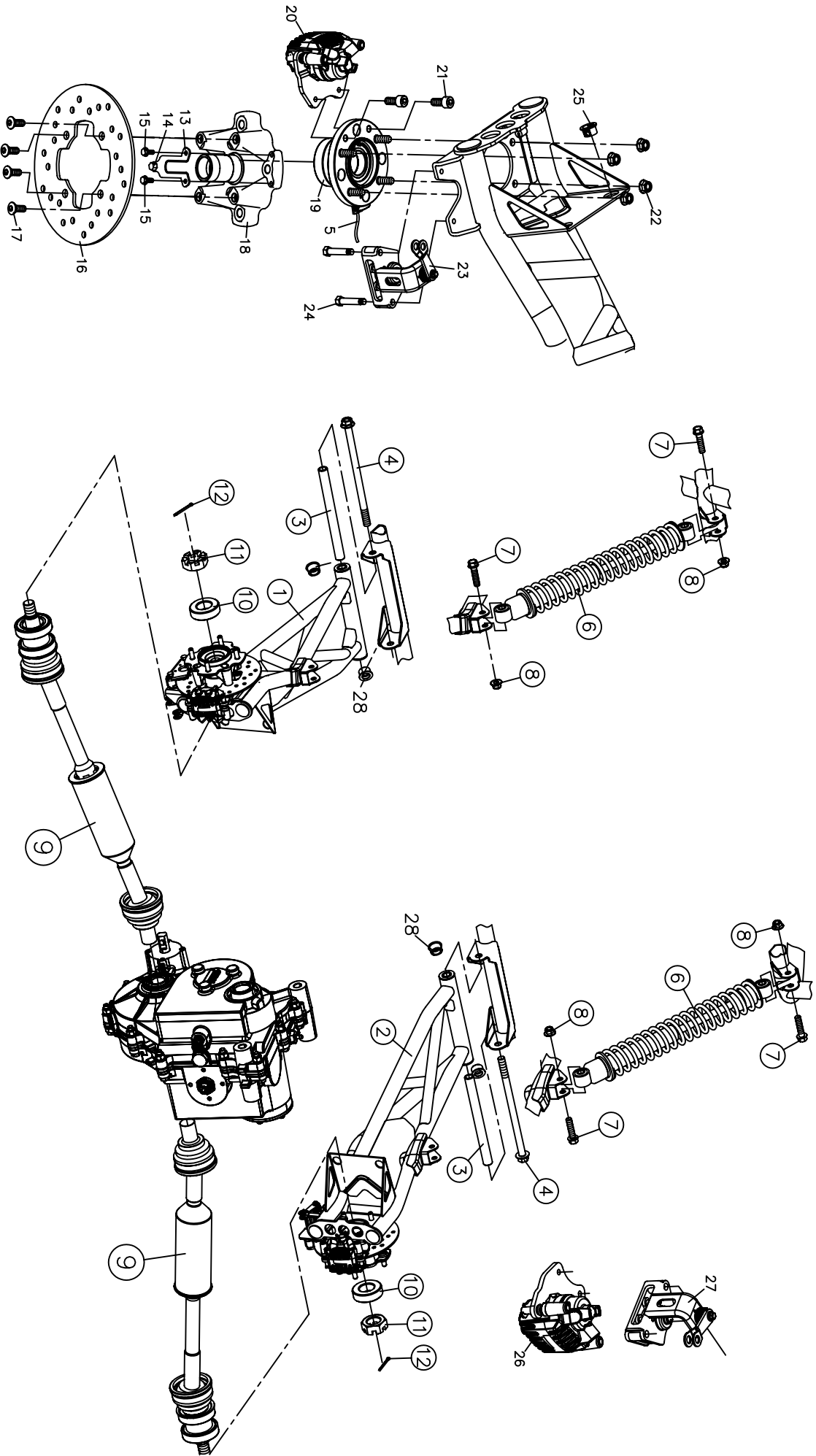

F11. REAR RACK

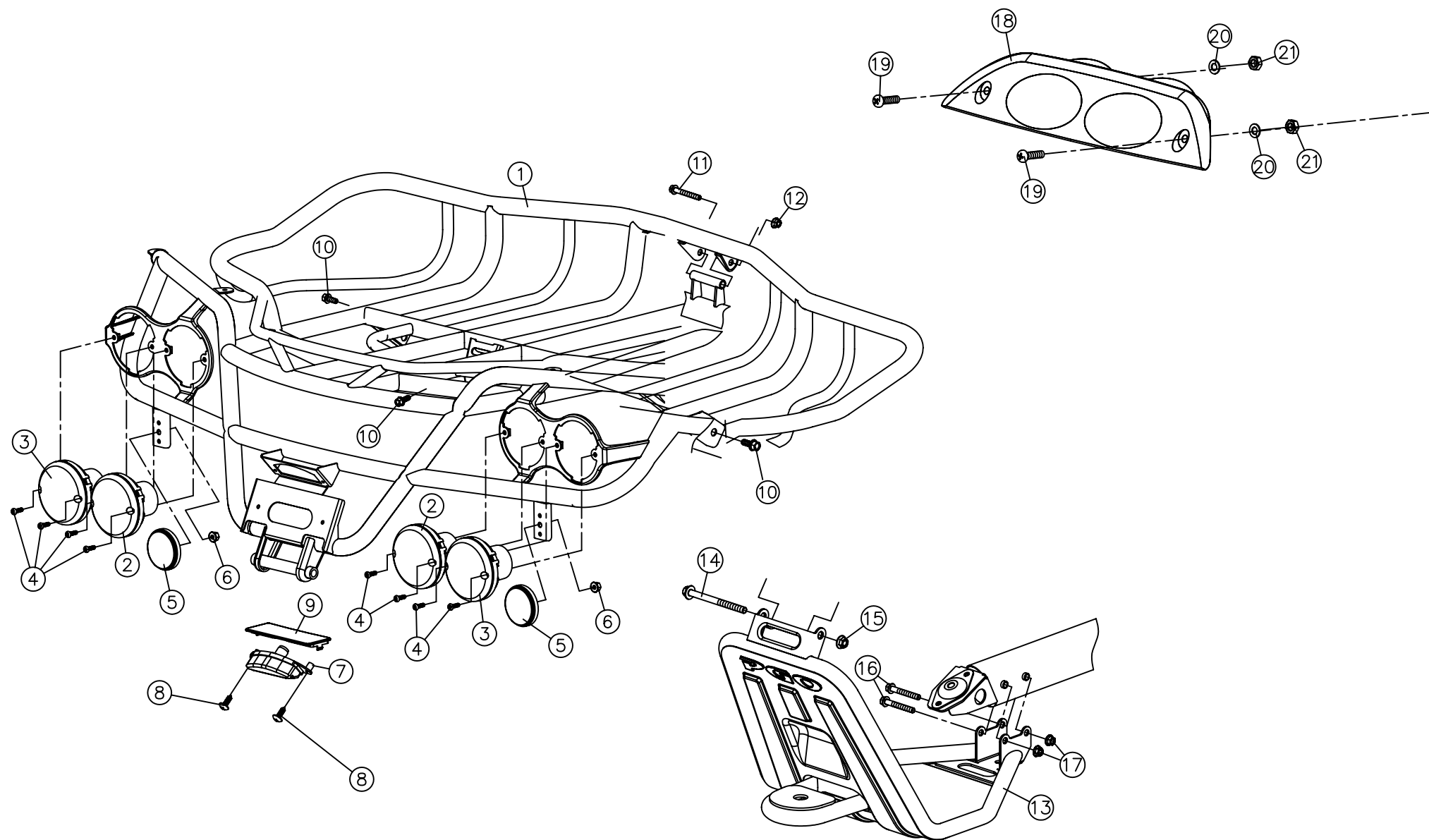

F12. FRONT BUMPER, HEAD LAMP

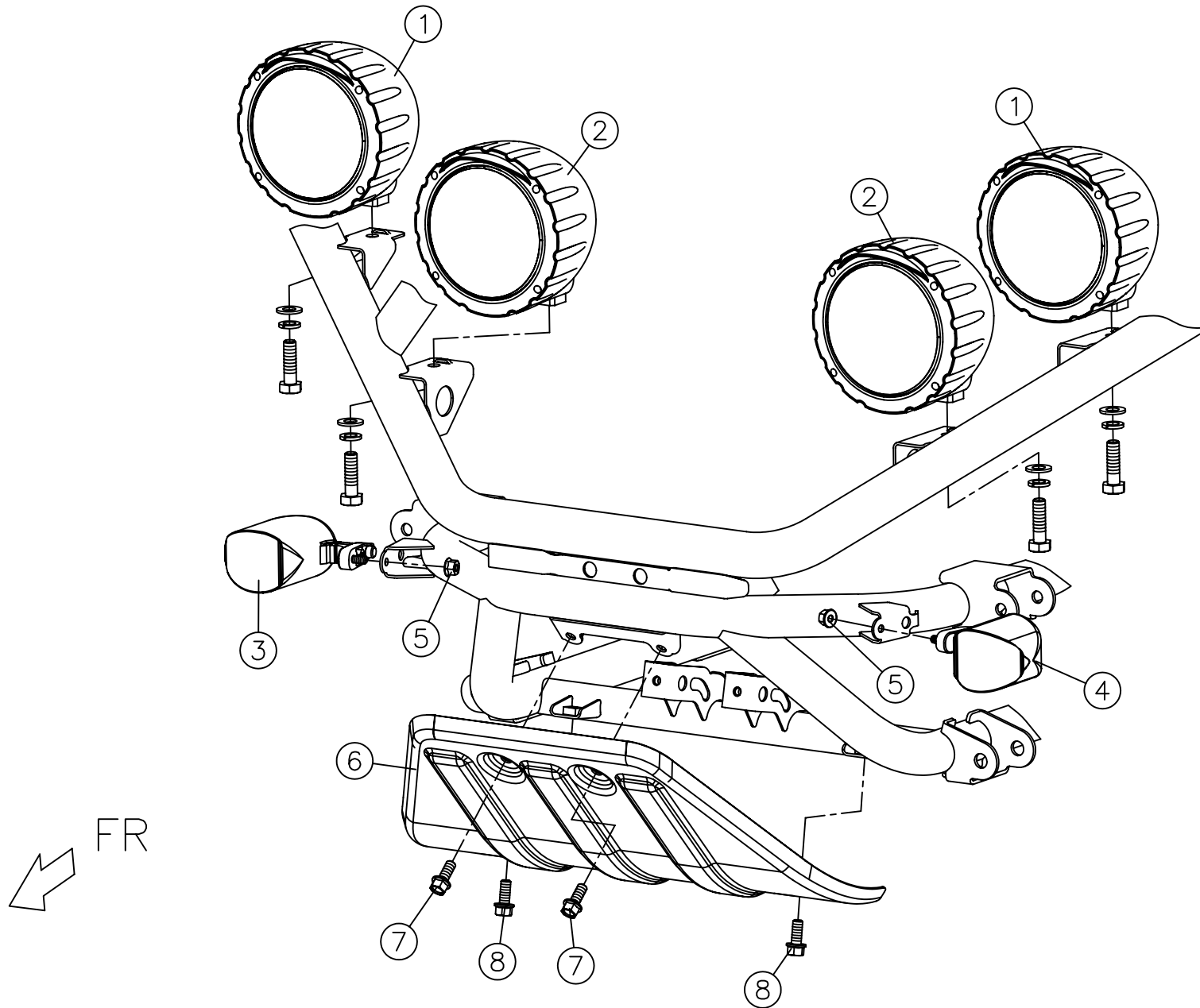

F14. DASHBOARD , COVER

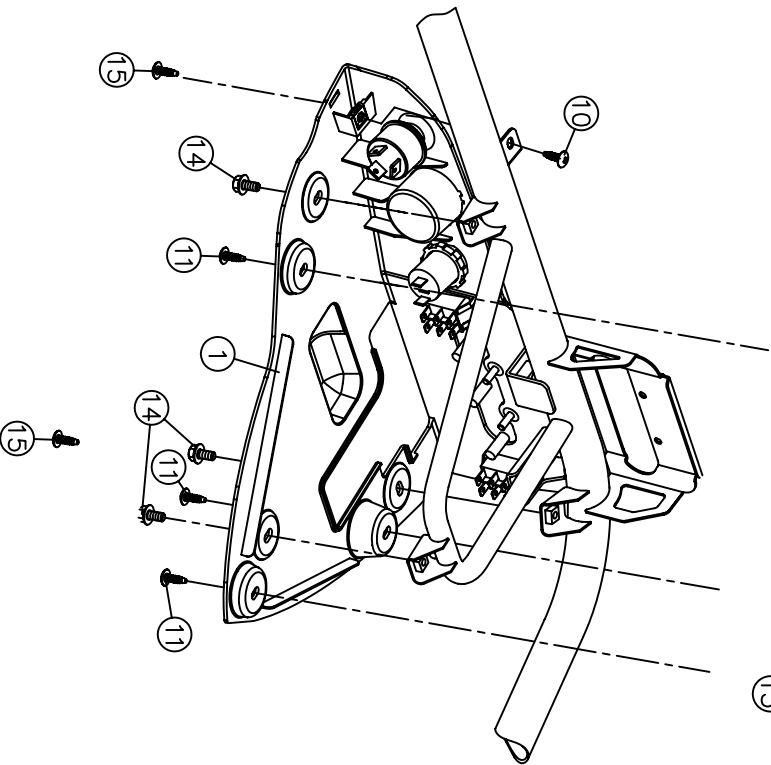
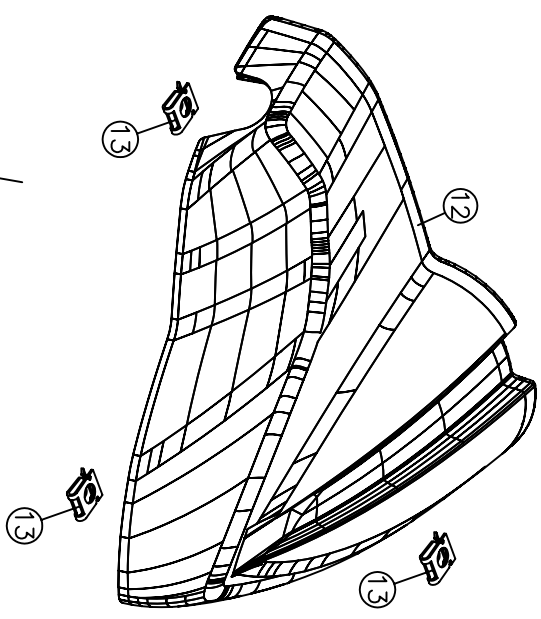
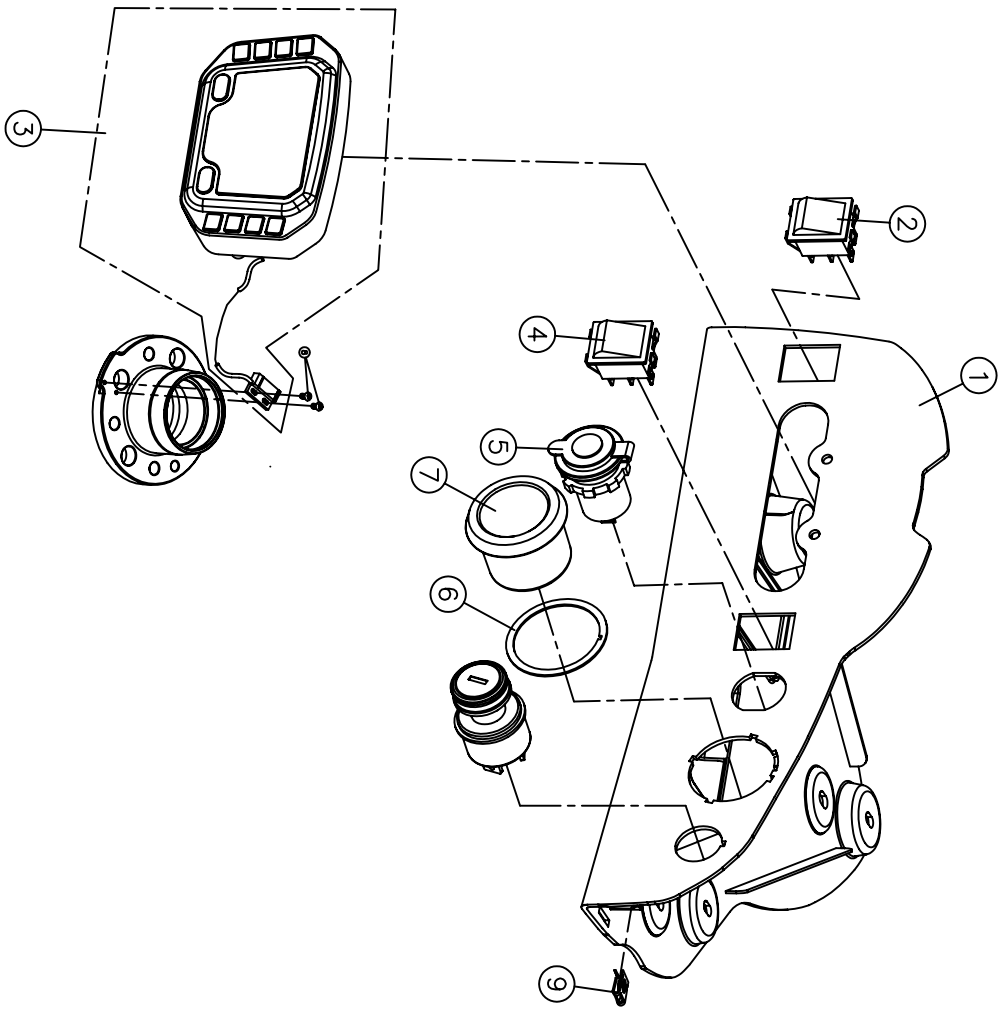

F15. COOLING SYSTEM

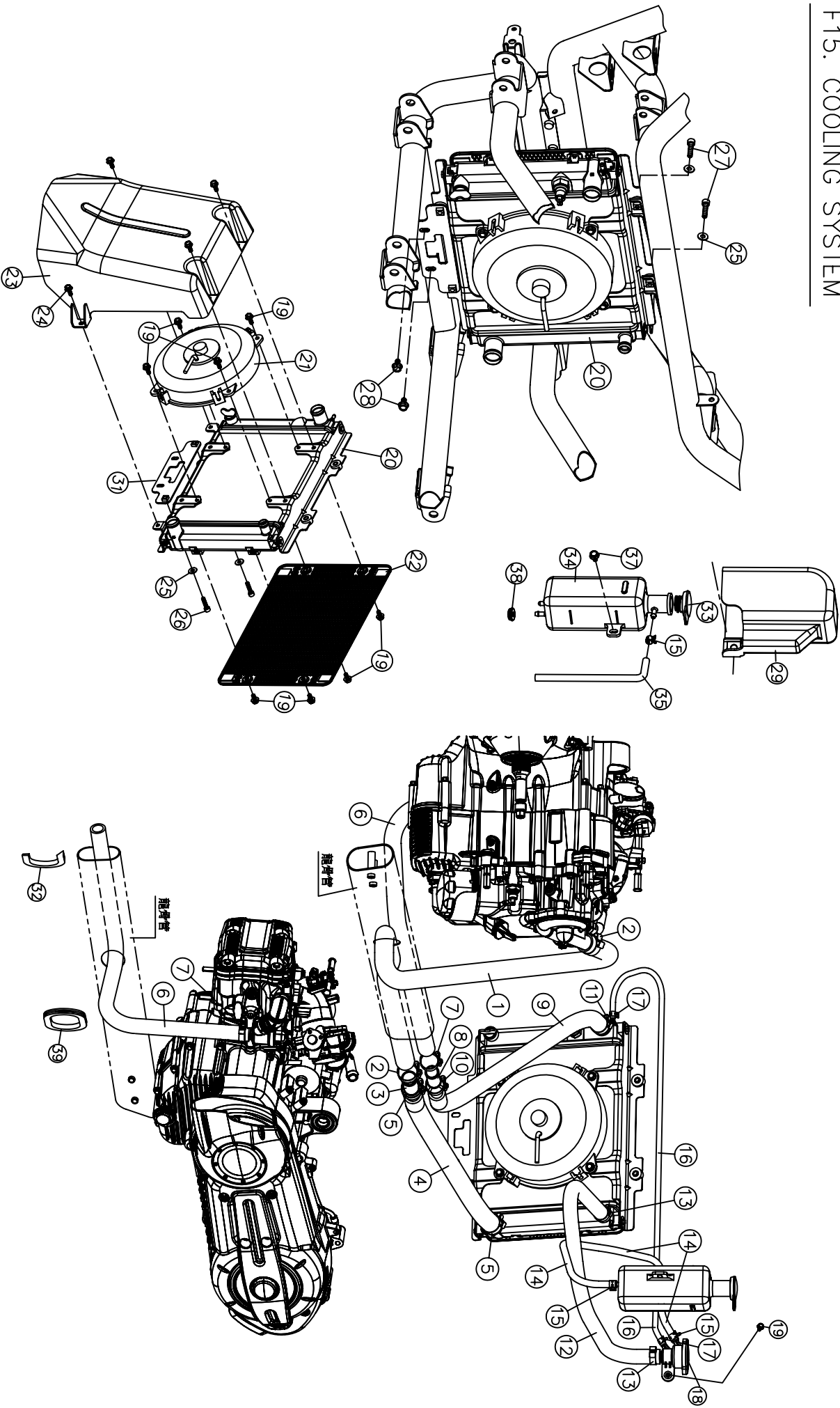

F15. COOLING SYSTEM

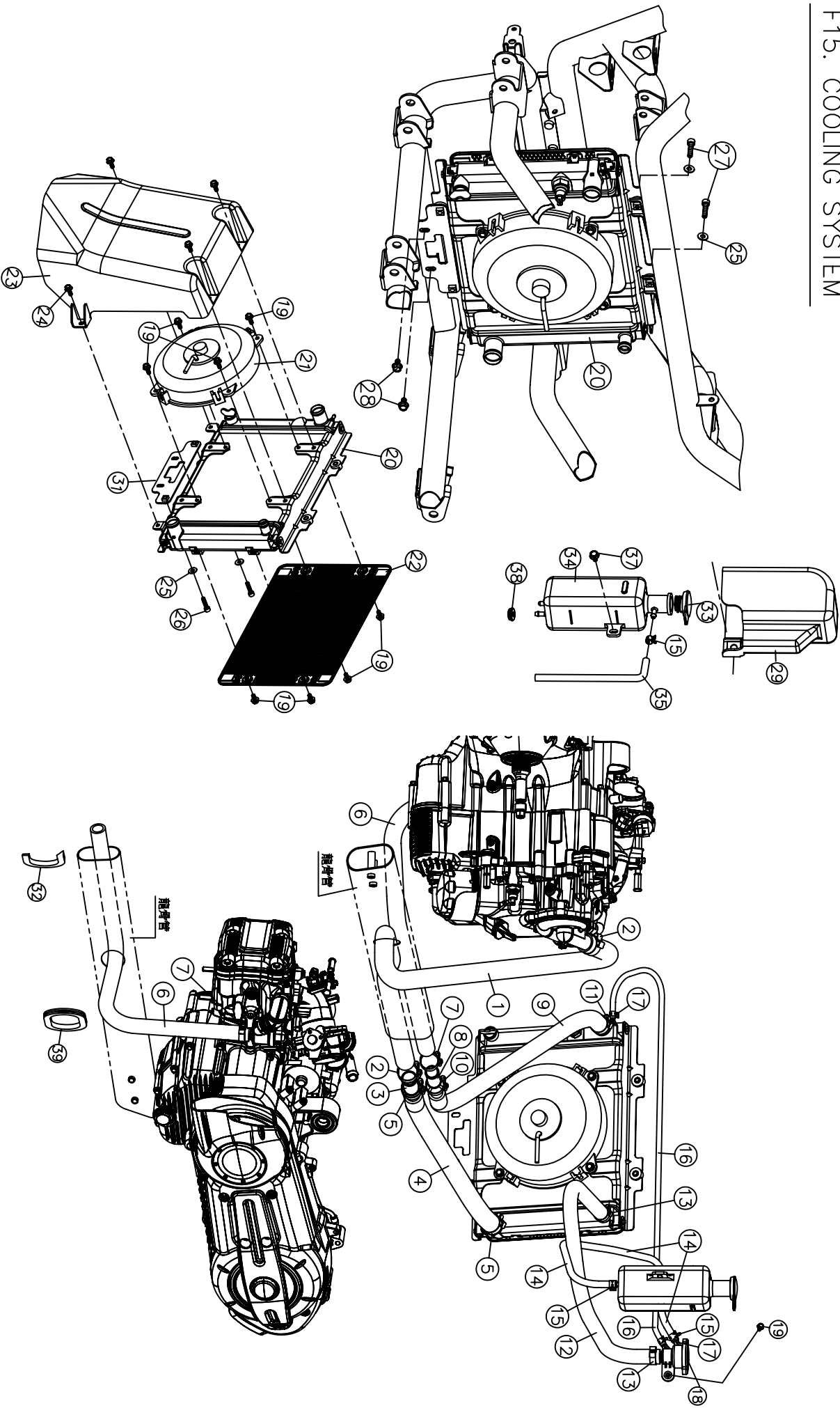

F16. ELECTRIC PARTS

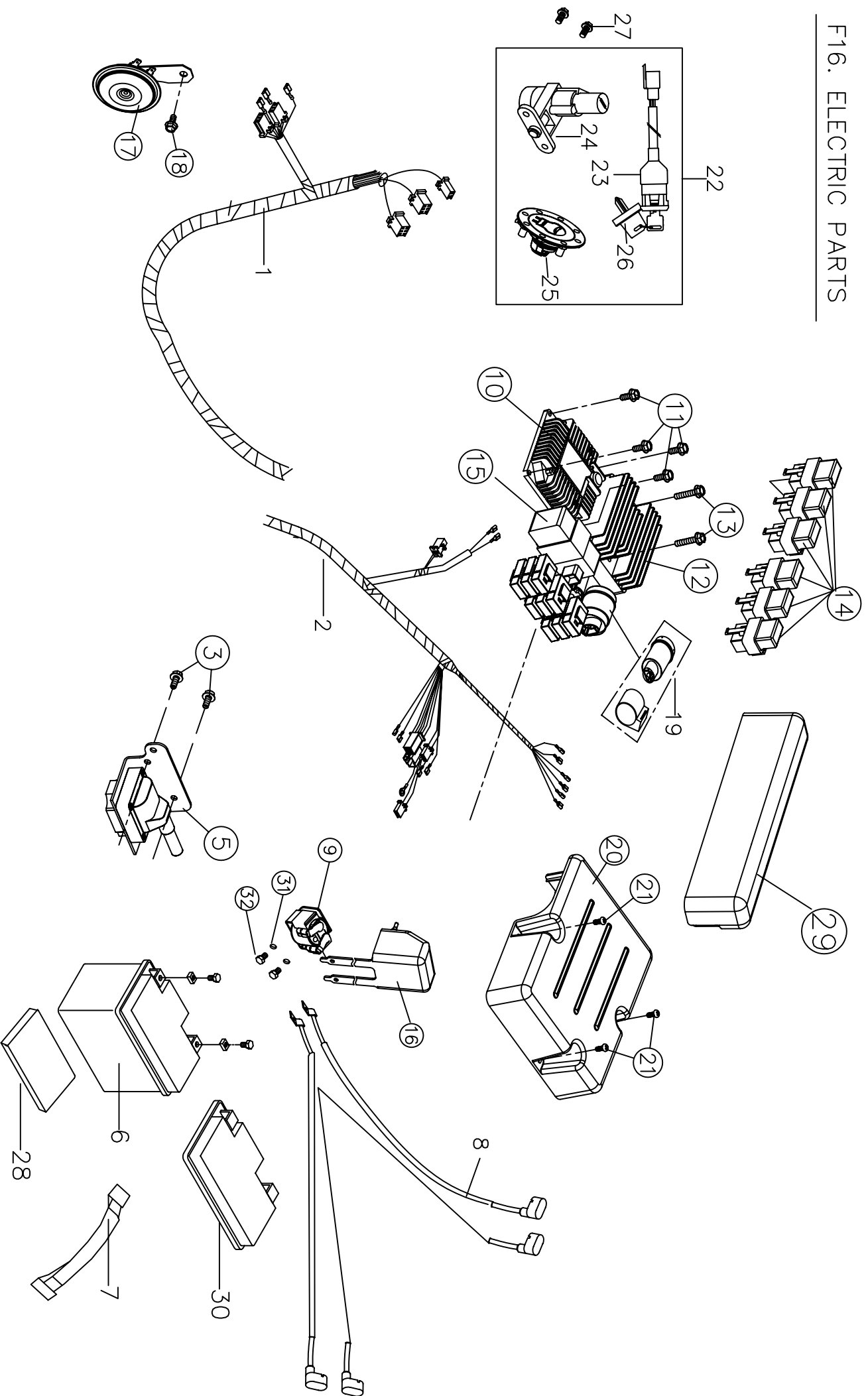

F16. ELECTRIC PARTS

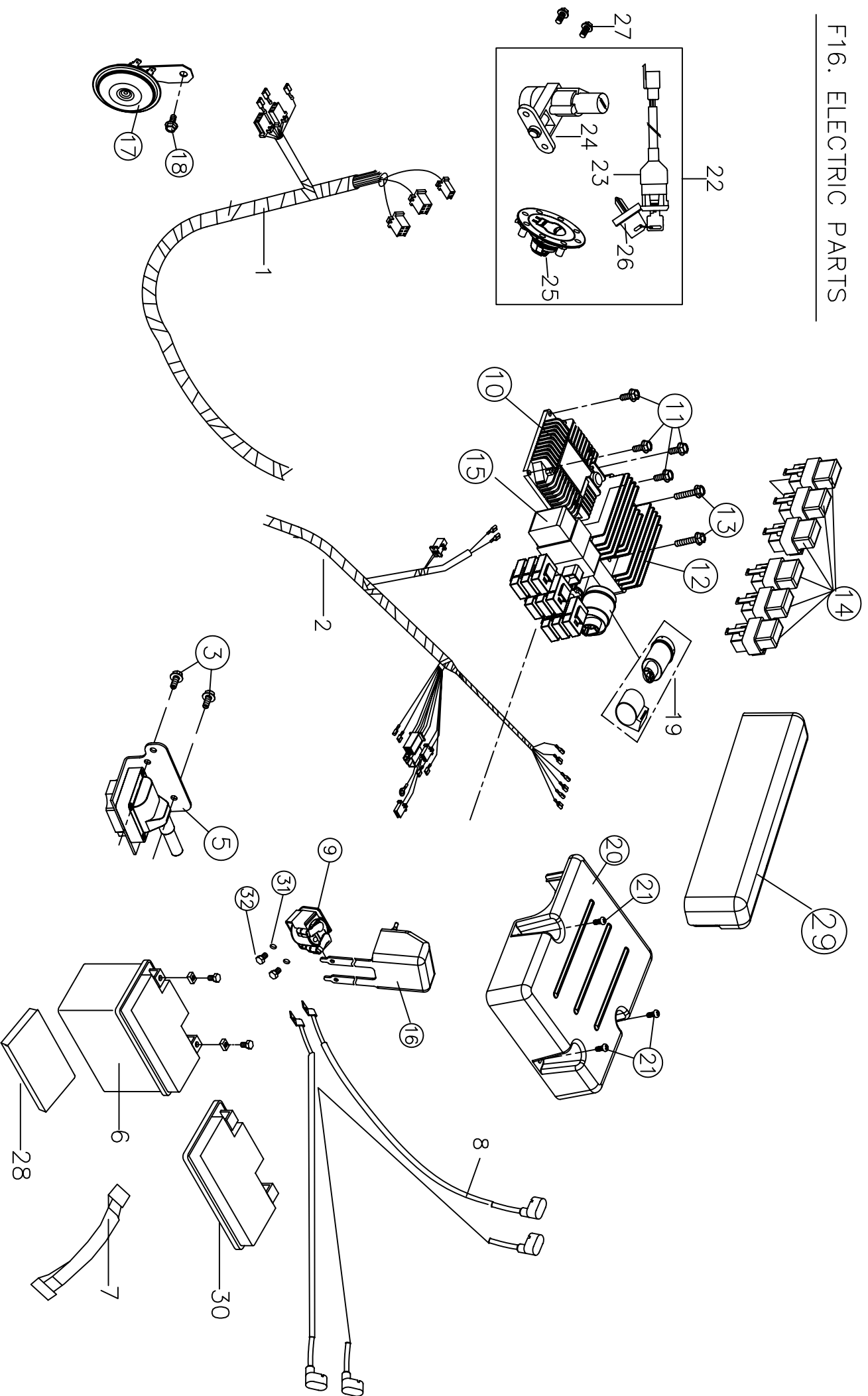

BR-500 LABELS

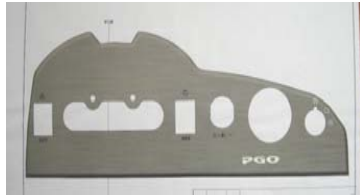

1

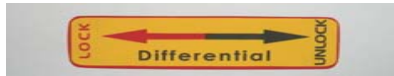

2



3



4



5



6



7

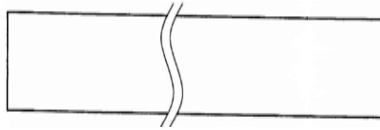

8



9

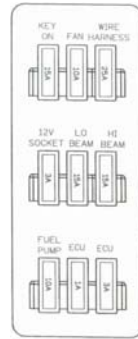

10



13



14



11

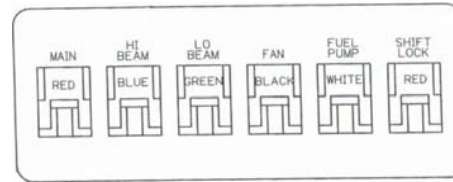

12

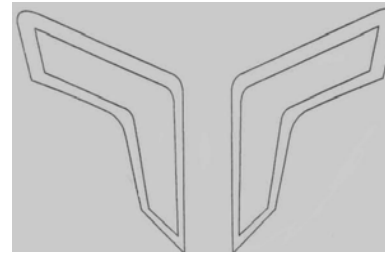

15

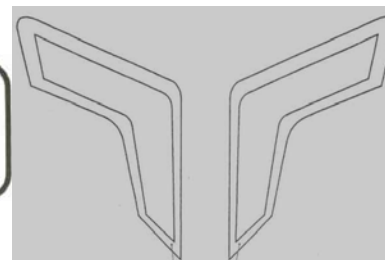

16

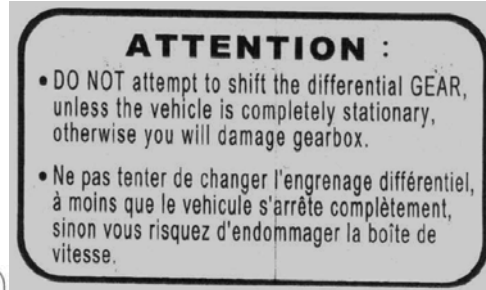

17

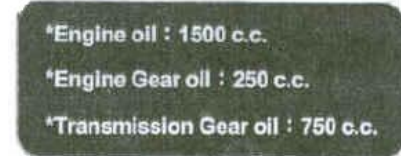

18



19



20



21