

Celebrating **50 Years** of Excellence.

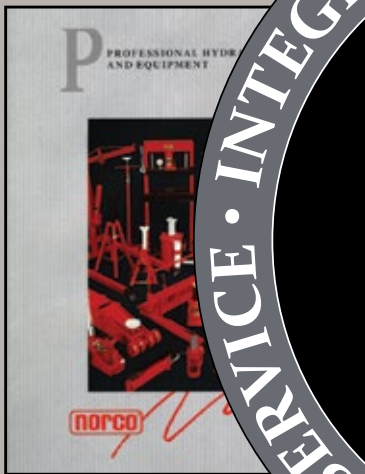
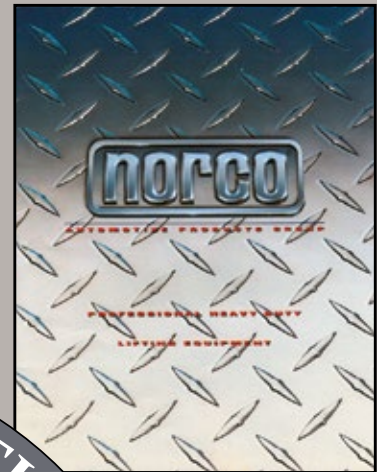
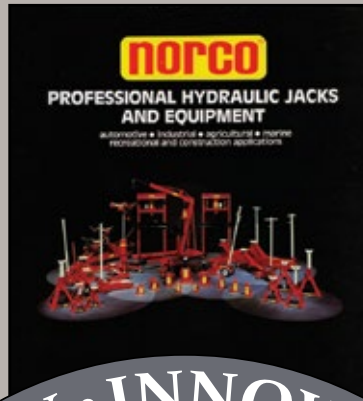
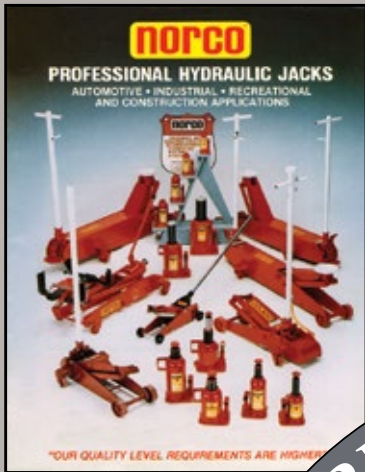

1964

**norco**<sup>®</sup>  
PROFESSIONAL LIFTING EQUIPMENT

**50**  
YEARS

SERVICE • INTEGRITY • INNOVATION • PERFORMANCE • QUALITY

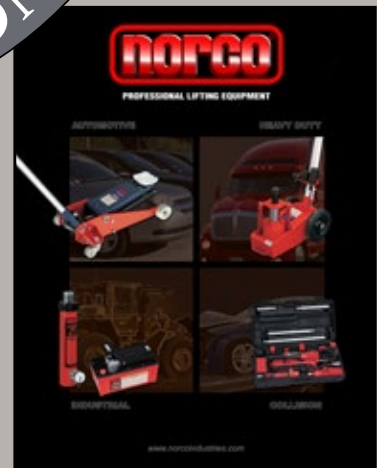
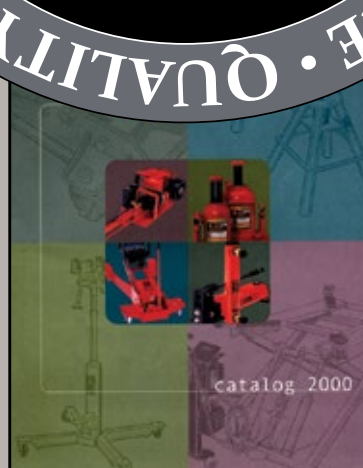
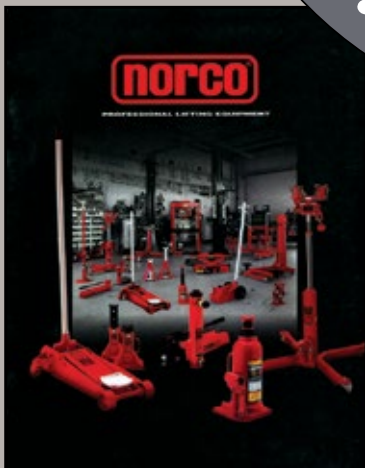

[www.norcoindustries.com](http://www.norcoindustries.com)



## NORCO Professional Lifting Equipment brand is proud to announce our 50th Anniversary!

The Tallmans built NORCO on the principles of providing our customers with quality products that exceed their expectations for performance, safety, and reliability, all at a competitive cost. We know we've been doing the right thing because, after half a century, the NORCO Brand is known around the world. When it comes to product development, "When Safety Depends on Performance" isn't just some tagline, it is our core value.

While we are proud of the products that we provide, we are most proud of the meaningful relationships that we've built along the way. The long-term relationships with our customers, employees, suppliers, and service support network are testimonies to the integrity that is demonstrated by everyone here at NORCO. It has been said, "Time flies when you're having fun." At NORCO not only have we had a lot of fun but we've made a lot of good friends along the way. For that we are most grateful.

From all of us at NORCO, we thank you for your continued loyalty and friendship. We look forward to providing you with another 50 years of quality products and service.



### USA Content and ASME / PALD

It is our intent to make as many products in the USA as possible. While we make some products that are 100% "Made in the USA," there are others with less U.S. content. We don't want to mislead the public, so we have come up with a single logo that will cover all of our USA products. When you see our new "U.S. Content" label next to a NORCO product, you can be assured that it has at least 51% USA content as required by the Buy American Act and Federal Acquisition Regulation (FAR).

Here at NORCO, we use the latest ASME/PALD guidelines for product development and testing. It ensures that our products are safe for the user and perform beyond their expectations. And, that's why all of our products, whether import or USA, are confidently covered by the NORCO Limited Lifetime Warranty. (Details on back cover)

Thank you again for the opportunity to offer you the best shop equipment value on the market.

**The NORCO Difference:**  
America's fastest and most durable

**norco AIR/HYDRAULIC AXLE JACKS** **1**



#### FEATURES

- 50" long "T" handle helps in positioning jack under vehicles with low overhang.
- The load release on the top mounted "T" handle allows operation at any handle position.
- Handle locking lever secures handle in either vertical, horizontal or 45 degree position.
- Compact design fits easily between tandem wheels.
- Rust inhibitive coating on ram and extension screw offers longer life.
- Large diameter wheels make maneuverability easy.
- Self-retracting ram eliminates manual lowering of jack.
- Safety by-pass system prevents cylinder damage.
- Safety overload system prevents jack from being used beyond its rated capacity.
- Integrated filter protects air motor.
- Fast lifting air motor.
- Three removable 2" diameter saddles with handle mounted saddle holder; 3/4", 2-1/4" and 4" in height.

**72200D**  
**22 TON CAPACITY**

**INTENDED USE**  
Ideal for heavy duty truck, agricultural and heavy construction equipment.

**72200D**  
(22 TON)

**72203**  
2-1/4" Extension Adapter Saddle

**72204**  
4" Extension Adapter Saddle



**72205**

**SADDLE ADAPTER KIT**  
Includes handle mounted saddle holder two adapters. Weight: 10 lbs.



MODEL NUMBER	CAPACITY	LIFT HEIGHT		STROKE	SCREW EXTENSION	OVERALL DIMENSIONS		P.S.I. RANGE	SHIPPING WEIGHT
		Low	High			Length	Width		
<b>72200D</b>	<b>22 Ton</b>	9"	18"	4.75"	4.25"	20"	13"	85-200	115 lbs.

**The NORCO Difference:**  
Its light weight makes it perfect for mobile repair service

**norco AIR/HYDRAULIC AXLE JACKS**

#### FEATURES

- Long handle with 36-1/2" reach helps in positioning jack under vehicles with low overhang.
- May be stored in a vertical position.
- Hand grip also works as a stand to store the jack in a vertical position.
- Compact design fits easily between tandem wheels.
- Parkerized coating on pump piston, extension screw and extension adapters and chrome coated ram offer protection against rust.
- Removable extension screw is used with the two 4" extension adapters (included) for added height when necessary.
- Self-retracting ram eliminates manual lowering of the jack.
- 5-1/4" diameter high impact composite wheels make maneuverability easy.
- Fast efficient air pump reduces lifting time and has a built-in relief mechanism which prevents the jack from being used beyond its maximum capacity.
- Convenient push button air valve connected to an in-line filter prohibits contaminants from entering the air/hydraulic system.

**72080A**

**STANDARD HEIGHT 20 TON CAPACITY**

**72090A**

**LOW HEIGHT 20 TON CAPACITY**

**INTENDED USE**  
Heavy duty truck, agricultural and heavy construction equipment. Ideal for loaded truck and trailer roadside service calls.

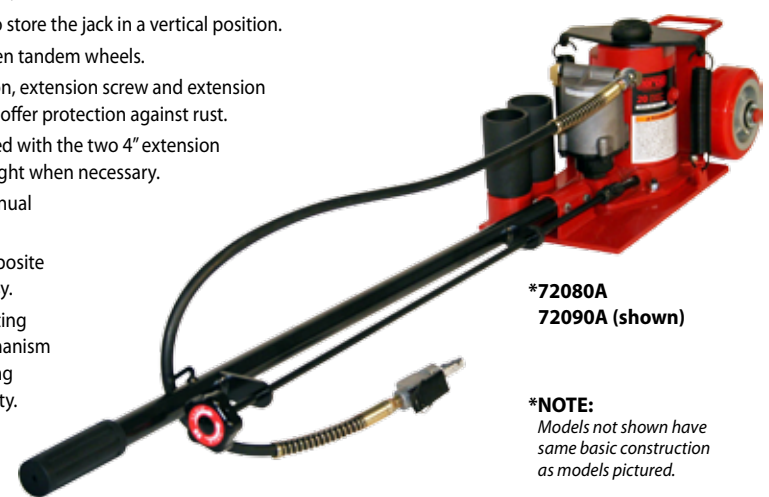

**\*72080A**  
**72090A (shown)**

**\*NOTE:**  
Models not shown have same basic construction as models pictured.

MODEL NUMBER	CAPACITY	LIFT HEIGHT		STROKE	SCREW EXTENSION	BASE SIZE	P.S.I. RANGE	SHIPPING WEIGHT
		Low	High					
<b>72080A</b>	<b>20 Ton</b>	11.125"	28.625"	6.625"	2.75"	9.25" x 17.25"	100-130	70 lbs.
<b>72090A</b>	<b>20 Ton</b>	8.625"	22.75"	4"	2.75"	9.25" x 17.25"	100-130	63 lbs.



**The NORCO Difference:**  
Tighter tolerances, better finishes,  
highest quality

**72212**

**55 / 37 / 23 / 12  
TON CAPACITY**

**72218**

**33 / 20  
TON CAPACITY**

**72225**

**50 / 25  
TON CAPACITY**

**INTENDED USE**

Heavy duty truck, rail, bus,  
agriculture and construction  
equipment applications.

**72244**

**44 TON CAPACITY**

**INTENDED USE**

Heavy duty truck, agricultural and  
heavy construction equipment.  
Ideal for loaded truck and trailer  
roadside service calls. Heavy enough  
for rail and bus work.

**FEATURES**

- Long "T" handle helps in positioning jack under vehicles with low overhang.
- Handle locking lever secures handle in either vertical, horizontal or 45 degree position.
- Safety overload system prevents cylinder damage.
- Rust inhibitive coating on rams offers longer life.
- Integrated filter protects air motor.
- Double acting pump raises ram more quickly to the load.
- Suspension loaded axle prevents wheel damage.
- Vacuum operated ram retraction eliminates manual lowering of jack.
- Safety button at the top of the handle can be pushed in to immediately stop the jack operation in case of emergency.
- Models 72212 and 72225 include a removable 2-3/4" diameter saddle, 2-9/16" and 5-7/8" long extensions with extension holder. Model 72218 includes 2" and 3-15/16" stackable extensions with extension holder.
- Model 72244 includes a removable 2-3/4" diameter saddle, 2" and 4" long stackable extensions and extension holder.

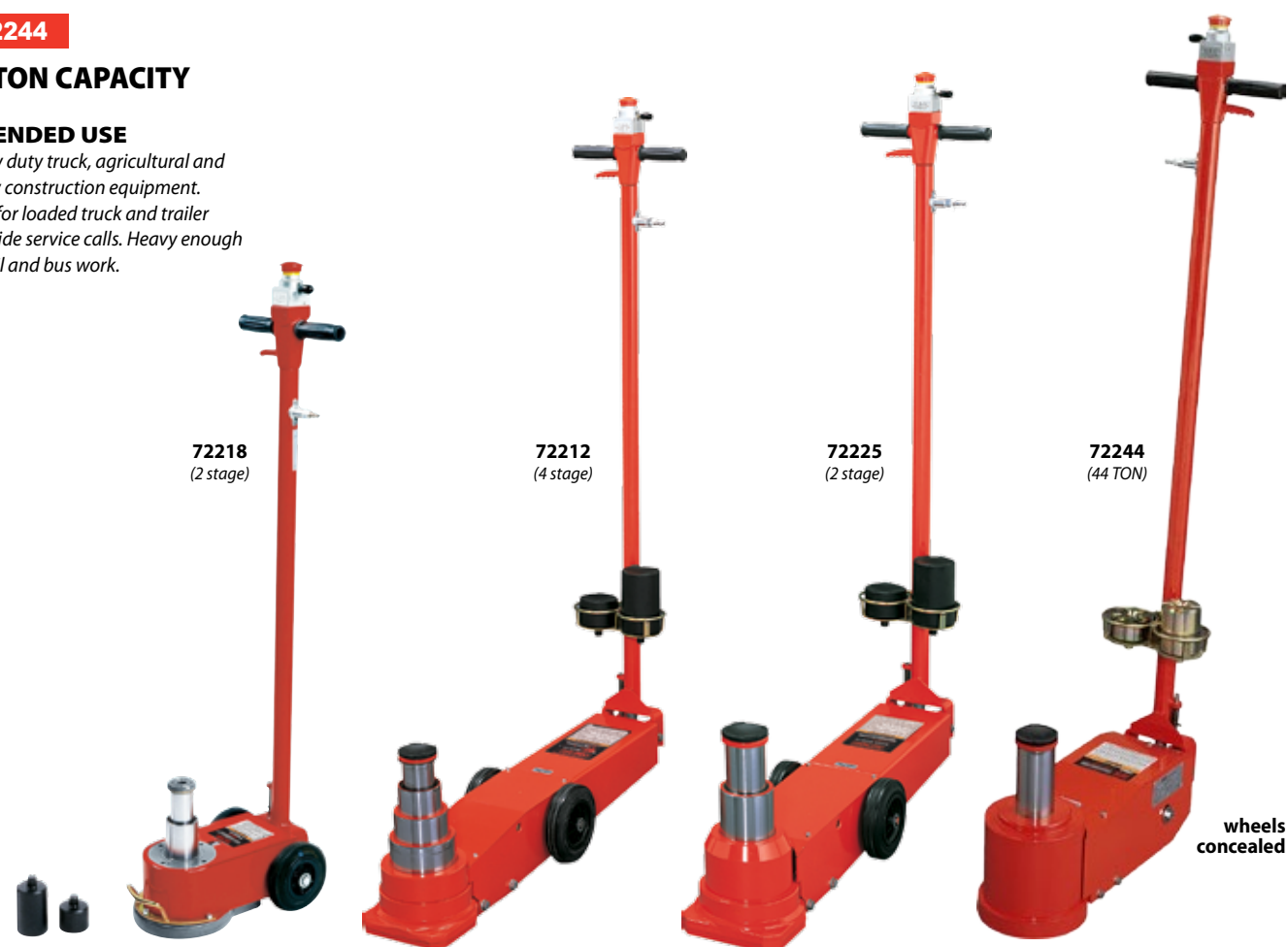

MODEL NUMBER	CAPACITY (TONS) @ LIFTING STAGE				LIFT HEIGHT		OVERALL DIMENSIONS		PISTON STROKE	HANDLE LENGTH	P.S.I. RANGE	SHIPPING WEIGHT
	1	2	3	4	Low	High	Length	Width				
<b>72212</b>	<b>55</b>	<b>37</b>	<b>23</b>	<b>12</b>	6"	15.375"	39.25"	8.625"	9.5"	61.75"	100-175	233 lbs.
<b>72218</b>	<b>33</b>	<b>20</b>	--	--	6"	12"	16"	6.75"	6.125"	49.25"	120-175	100 lbs.
<b>72225</b>	<b>50</b>	<b>25</b>	--	--	8.75"	16.5"	39.25"	8.625"	7.875"	61.75"	120-175	235 lbs.
<b>72244</b>	<b>44</b>	--	--	--	9.25"	15.625"	21.625"	8.125"	5.5"	61.75"	130-175	149 lbs.



**The NORCO Difference:**  
Highest 5 ton lift height on the market

**FEATURES**

- Chromed ram and dust seals prevent hydraulic contamination.
- Safety by-pass and overload systems protect hydraulic block.
- Air pump models can also be operated manually.
- All models except for the 72230A include the FASTJACK® feature which raises the jack's lifting saddle to the load with one pump of the "T" handle.
- Locking release lever secures handle in the vertical, 45 degree or horizontal position to lower the load on all models.

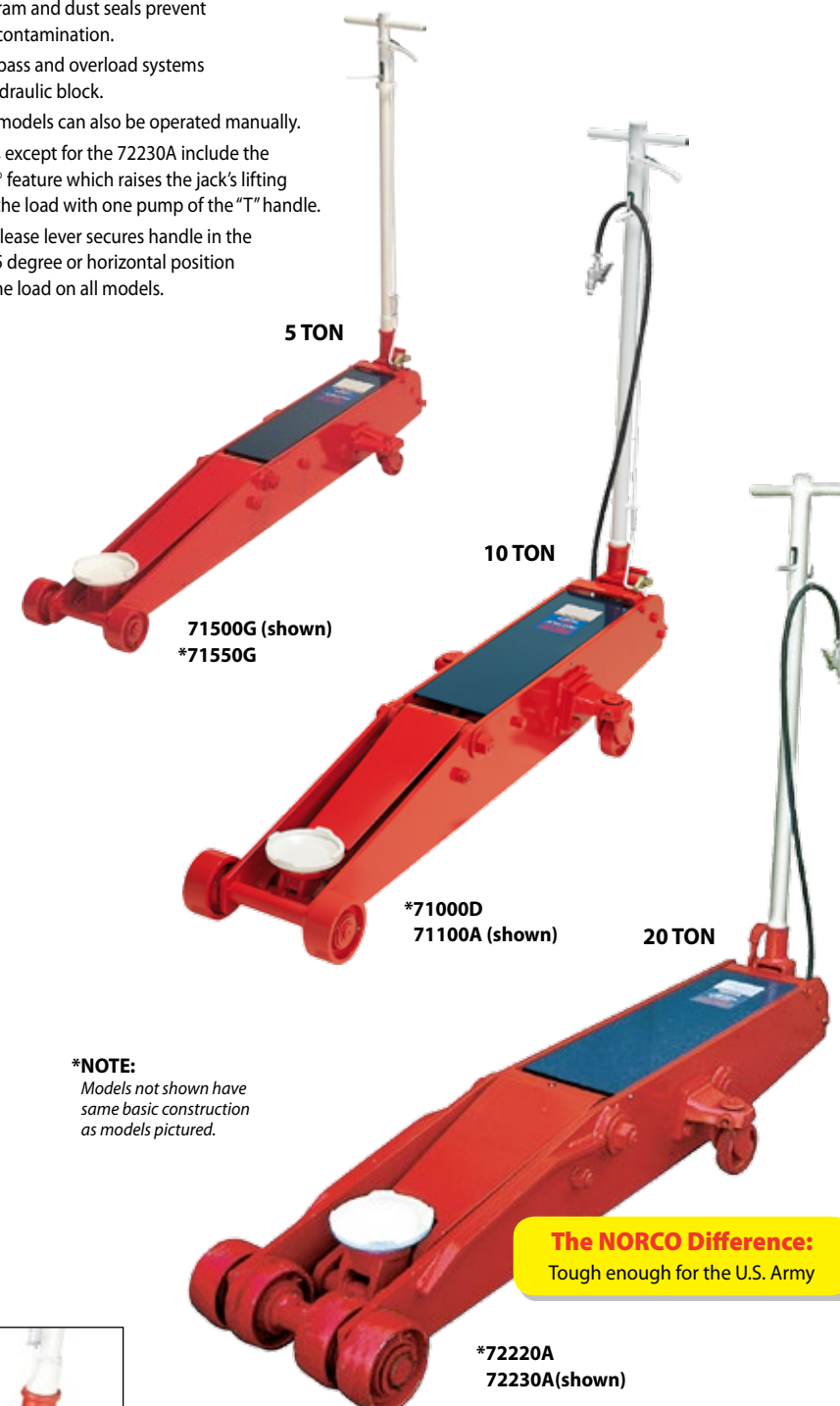

**\*NOTE:**  
Models not shown have  
same basic construction  
as models pictured.

**The NORCO Difference:**  
Tough enough for the U.S. Army



**FASTJACK®** mechanism  
raises the jack's lifting  
saddle to the load in  
one pump stroke.  
U.S. PATENT NUMBER  
7,055,801 B2



MODEL NUMBER	CAPACITY	LIFT HEIGHT		OVERALL DIMENSIONS		HANDLE LENGTH	SHIPPING WEIGHT
		Low	High	Length	Width		
<b>71500E</b>	<b>5 Ton</b>	5.625"	27.25"	62.25"	16.75"	40"	270 lbs.
<b>71550E</b>	<b>5 Ton @ 120 P.S.I.</b>	5.625"	27.25"	62.25"	16.75"	40"	270 lbs.
<b>71000D</b>	<b>10 Ton</b>	6.125"	27.25"	68.5"	21"	46.75"	455 lbs.
<b>71100A</b>	<b>10 Ton @ 120 P.S.I.</b>	6.125"	27.25"	68.5"	21"	46.75"	466 lbs.
<b>72220A</b>	<b>20 Ton</b>	7.25"	26.25"	71.5"	20.75"	45"	650 lbs.
<b>72230A</b>	<b>20 Ton @ 120 P.S.I.</b>	7.25"	26.25"	71.5"	20.75"	45"	670 lbs.

**FASTJACK® 71500G**

**5 TON CAPACITY**

**FASTJACK® 71550G**

**5 TON CAPACITY**

**(Air & Hydraulic)**

**INTENDED USE**

Truck fleet, truck and farm  
equipment dealers and bus  
company garages.

**The NORCO Difference:**  
One pump to reach the load

**FASTJACK® 71000D**

**10 TON CAPACITY**

**FASTJACK® 71100A**

**10 TON CAPACITY**

**(Air & Hydraulic)**

**FASTJACK® 72220A**

**20 TON CAPACITY**

**72230A**

**20 TON CAPACITY**

**(Air & Hydraulic)**

**INTENDED USE**

Heavy duty truck, heavy  
construction and agricultural  
equipment maintenance garages.

**71202A FASTJACK****2 TON CAPACITY FLOOR JACK****INTENDED USE**

A heavy-duty professional quality floor jack designed for a variety of automotive shop uses including the day to day rigors of the tire changing industry.

**71228****STEEL WHEEL KIT**

Fits model 71202A

Weight: 10 lbs.

**71226****HANDLE PROTECTOR KIT**

Fits models 71202A, 71233A & 71335  
Weight: 1 lbs.

MODEL NUMBER	CAPACITY	LIFT HEIGHT		OVERALL DIMENSIONS		SHIPPING WEIGHT
		Low	High	Length	Width	
<b>71202A</b>	<b>2 Ton</b>	3.5"	20.375"	28.75"	15.25"	102 lbs.

**71233A****2 TON CAPACITY DOUBLE PUMP FLOOR JACK****INTENDED USE**

An economical floor jack designed for a variety of automotive shop uses where strength, speed, and dependability are required.

**The NORCO Difference:**  
Economical performance

**FEATURES**

- Extremely low 2-3/4" low lift height.
- Safety by-pass system protects pressure cylinder.
- Safety overload system prevents jack from being used beyond its rated capacity.
- Heavy duty chassis for added strength and dependability.
- 50.25" long two-piece handle for easy shipping and storage.
- Foam handle sleeve is included to protect vehicles from damage.
- Dual pump piston design raises the jack to maximum height in 8-1/2 pump strokes.
- U-joint release mechanism for more control.

MODEL NUMBER	CAPACITY	LIFT HEIGHT		OVERALL DIMENSIONS		SHIPPING WEIGHT
		Low	High	Length	Width	
<b>71233A</b>	<b>2 Ton</b>	2.75"	20"	27.875"	14.625"	92 lbs.

**71330****3 TON CAPACITY LIGHTWEIGHT FLOOR JACK****INTENDED USE**

A lightweight jack designed for a variety of automotive shop uses. Ideal for roadside service calls.

**FEATURES**

- Thick aluminum side plates.
- 48" long two-piece handle with foam handle sleeve.
- Heavy duty aluminum front and rear wheels.
- Two-speed pump piston raises the saddle to the load quickly.
- Two grab handles provide more convenient lifting of the jack.
- Steel lift saddle for greater durability and strength.
- High lift height may be increased by 3" with optional model 71303 extension adapter.

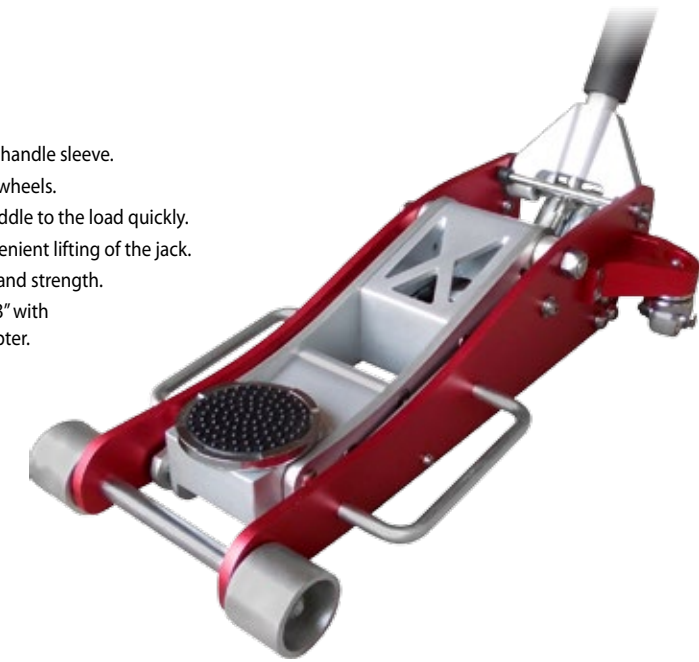

MODEL NUMBER	CAPACITY	LIFT HEIGHT		OVERALL DIMENSIONS		SHIPPING WEIGHT
		Low	High	Length	Width	
<b>71330</b>	<b>3 Ton</b>	3.75"	19"	26"	13.5"	59 lbs.

**71303****3" SADDLE EXTENSION ADAPTER**

Fits model 71330 & 71335

Weight: 5 lbs.



U.S. PATENT NUMBER D683104

**FEATURES**

- Steel hydraulic block construction includes a double pump piston design that quickly raises the jack to the maximum height.
- 50" long, two piece handle with knurled hand grip and foam handle sleeve provides:
  - Ease of pumping.
  - Longer reach for positioning under overhang.
  - Ease for transportation and storage.
  - Ease of pumping in tight quarters when second handle section is removed.
- 4" low and 21-3/8" maximum lift heights (without saddle adapter).
- 7" low and 24-3/8" maximum lift heights (with saddle adapter).
- Safety by-pass system protects pressure cylinder.
- Safety overload system prevents jack from being used beyond its rated capacity.
- Heavy-duty chassis for added strength and dependability.
- Also available is our unique 3" saddle extension adapter (Model 71303). Its patented design has been created to quickly lift the load. Since most SUVs and service trucks have a higher, low lift height, the increased height of the saddle allows for quicker positioning and quicker lifting of the vehicle. It saves time and effort and increases shop efficiency.

**The NORCO Difference:**  
Highest lift height on the market with 71303 extension adapter



MODEL NUMBER	CAPACITY	LIFT HEIGHT		OVERALL DIMENSIONS		SHIPPING WEIGHT
		Low	High	Length	Width	
<b>71335</b>	<b>3-1/2 Ton</b>	4"	21.375"	28.5"	14.375"	106 lbs.

**71335****3-1/2 TON CAPACITY SUV & SERVICE TRUCK JACK****INTENDED USE**

A heavy-duty floor jack designed for a variety of automotive shop uses including the added capacity and maximum lift height required to handle most SUVs and 1 Ton+ service trucks.

**71303****3" SADDLE EXTENSION ADAPTER**

Fits model 71330 & 71335

Weight: 5 lbs.



U.S. PATENT NUMBER D683104

**The NORCO Difference:**

Spring-loaded locking mechanism and hidden foot pads

**81004C & 81006D****PAIRS OF STANDS  
3 & 6 TON CAPACITY***(Each Stand)***INTENDED USE***For automotive use where vehicle is to be supported before making repairs.***FEATURES**

- Unique spring loaded pawl provides constant locking pressure against lifting column.
- Four legged base with foot pads for added strength and a more secure footing on asphalt.
- Common machine bolt secures lifting column to stand and provides added strength when stand is continuously lifted and handled by the column.
- Recessed column saddle for acceptance of vehicle panel rail (model 81004C only).
- Positive lock handle cannot be disengaged until load is off the saddle column. Lock handle can be used as a carrying handle.

**ALL STANDS ARE INTENDED TO BE USED IN PAIRS.****81012****PAIR OF STANDS  
12 TON CAPACITY***(Each Stand)***INTENDED USE***Fleet garages, agricultural and construction maintenance shops.***81004C**  
*(3 TON)***81006D**  
*(6 TON)***81012**  
*(12 TON)*

MODEL NUMBER	CAPACITY (Each Stand)	HEIGHT		HEIGHT INTERVALS	BASE SIZE	SADDLE SIZE	SHIPPING WEIGHT
		Low	High				
<b>81004C</b>	<b>3 Ton</b>	12"	17.5"	.5625"	7.5" x 7.875"	1.125" x 4.625"	19 lbs.
<b>81006D</b>	<b>6 Ton</b>	16.25"	24.875"	.625"	10" x 11"	1.125" x 4.875"	30 lbs.
<b>81012</b>	<b>12 Ton</b>	19.625"	29.375"	1.25"	13" x 15"	1.625" x 4.75"	86 lbs.

**TRUCK RAMPS** **NORCO****The NORCO Difference:**

Your choice of narrow or wide ramps

**82019****82020****PAIR OF TRUCK RAMPS  
20 TON CAPACITY***(10 Ton Each Ramp)***INTENDED USE***Elevates front or rear of vehicle for access to frame and components. Particularly useful on vehicles with low profile or ground-effects.***FEATURES**

- Handles tires with up to 16" tread widths.
- Telescopic 34" T-handle extends and lifts up to expose wheels for easy maneuverability around the shop. Retracts for easy storage.
- Perforated holes in ramps provide traction for the tires.
- Non-skid rubber base pads prevent slippage when driving onto or off of ramps.

**\*82019  
82020 (shown)**

MODEL NUMBER	CAPACITY (Each Ramp)	OVERALL DIMENSIONS			SHIPPING WEIGHT
		Length	Width	Height	
<b>82019</b>	<b>10 Ton</b>	48.25"	12.625"	9"	204 lbs.
<b>82020</b>	<b>10 Ton</b>	50.5"	18.375"	9.25"	346 lbs.

**\*NOTE:** Model not shown has same basic construction as model pictured.**The NORCO Difference:**

We offer a choice of American or import models

**81205****IMPORT 81205i****PAIR OF STANDS  
5 TON CAPACITY***(Each Stand)***INTENDED USE***Low profile design in order to support forklifts and heavy machinery.***81208****IMPORT 81208i****PAIR OF STANDS  
SHORT HEIGHT  
10 TON CAPACITY***(Each Stand)***81209****IMPORT 81209i****PAIR OF STANDS  
MEDIUM HEIGHT  
10 TON CAPACITY***(Each Stand)***81210****IMPORT 81210i****PAIR OF STANDS  
HIGH HEIGHT  
10 TON CAPACITY***(Each Stand)***INTENDED USE***Fleet garages, agricultural and construction maintenance shops where a pin type height adjustment column is desired.***81225****IMPORT 81225i****PAIR OF STANDS  
25 TON CAPACITY***(Each Stand)***INTENDED USE***Fleet and maintenance garages where low profile stands are used to support trucks and loaded trailers.***81205 (shown)  
\*81205i  
(5 TON)****FEATURES**

- Pin type support column adjusts to four different height positions.
- Heavy duty adjustment pin is secured to stand to prevent loss.
- Handle provides ease of positioning and carrying.
- 9" square base secures and stabilizes load.

**\*NOTE:***Models not shown have same basic construction as model pictured. Import models differ slightly from models made in U.S.A.***FEATURES**

- Pin type support column adjusts to multiple height positions. See specification chart below.
- Adjustment pin is secured to stand to prevent loss.
- Four legged base made of heavy schedule 2" diameter pipe for added stability.
- Large support saddle with locating lugs position and center load.

**\*81208  
\*81208i  
(SHORT HEIGHT)****81209 (shown)  
\*81209i  
(MED. HEIGHT)****\*81210  
\*81210i  
(HIGH HEIGHT)  
(10 TON)****81225 (shown)  
\*81225i  
(25 TON)****FEATURES**

- Pin type support column adjusts to four different height positions.
- Adjustment pin is secured to stand to prevent loss.
- Handle provides ease of positioning and carrying.
- 3/8" thick solid steel base plate for added stability.

**ALL STANDS ARE INTENDED TO BE USED IN PAIRS.**

MODEL NUMBER	CAPACITY (Each Stand)	HEIGHT		HEIGHT INTERVALS	BASE SIZE	SADDLE SIZE	SHIPPING WEIGHT	
		Low	High					
<b>81205</b>	<b>81205i</b>	<b>5 Ton</b>	9.5"	15.75"	3 x 2"	9" x 9"	3" x 4.5"	38 lbs.
<b>81208</b>	<b>81208i</b>	<b>10 Ton</b>	10.5"	17"	4 x 1.5"	12.5" x 12.5"	3" x 5"	60 lbs.
<b>81209</b>	<b>81209i</b>	<b>10 Ton</b>	18.5"	30"	7 x 1.5"	17" x 17"	3" x 5"	80 lbs.
<b>81210</b>	<b>81210i</b>	<b>10 Ton</b>	28"	47"	10 x 2"	16" x 16"	3" x 5"	106 lbs.
<b>81225</b>	<b>81225i</b>	<b>25 Ton</b>	12"	20"	3 x 3"	10" x 10"	2.25" x 3.25"	65 lbs.



81022A



IMPORT 81022Ai

## 20 TON CAPACITY

## INTENDED USE

To stabilize and assist in supporting the front or rear end of a loaded or unloaded tractorless trailer. Sold individually but generally used in pairs.

81022A  
81022Ai  
(20 TON)

81033A

## 3/4 TON CAPACITY

81034A

## 3/4 TON CAPACITY

## INTENDED USE

Designed to support vehicle components, not the vehicle. Ideal for exhaust system installation, shock absorber replacement and any task which requires relieving pressure off components.

81034A (shown)  
81033A (without pedal)  
(3/4 TON)81035A  
(1-1/2 TON)

81035A

## 1-1/2 TON CAPACITY

## INTENDED USE

To assist in stabilizing and supporting a vehicle that is raised by an in-ground or above-ground lift. Should be used in pairs.

81036A



## 1 TON CAPACITY

## INTENDED USE

For lifting and positioning exhaust systems, shock absorbers and MacPherson struts. Hydraulic power will assist in freeing frozen spring shackles, aligning wheels and steering gear adjustments.

81036A  
(1 TON)

MODEL NUMBER	CAPACITY (Each Stand)	LOW HEIGHT	EXTENDED HEIGHT	BASE SIZE	SADDLE SIZE	SHIPPING WEIGHT
81022A 81022Ai	20 Ton	39"	50.625"	14" Dia.	4.5" x 5"	52 lbs.
81033A	3/4 Ton	55.25"	81.5"	12" Dia.	1.625" x 5.25"	36 lbs.
81034A	3/4 Ton	55.25"	81.5"	12" Dia.	1.625" x 5.25"	40 lbs.
81035A	1-1/2 Ton	48.875"	85.375"	12" x 12" x 12"	3.25" x 3.25"	48 lbs.
81036A	1 Ton	56.25"	94.375"	12" Dia.	4" x 6.25"	51 lbs.



## FEATURES

## (Models 81022A &amp; 81022Ai)

- Meets OSHA requirements for supporting trailers when loaded or unloaded.
- 14" diameter base provides maximum leveling stability.
- Quick adjust spin handle for ease of turning.
- Large diamond plate saddle to grip the load.
- 1-1/2" diameter, grade 5, heavy duty screw and nut provide maximum strength and fine adjustment.

## FEATURES

## (Models 81033A &amp; 81034A)

- Lightweight, slender design makes handling easy, even in close quarters.
- Quick adjust spin handle with thrust bearing eliminates wear and provides ease of turning under load.
- Foot pedal (Model 81034A only) generates 1" additional stroke and 400 pounds of force at the saddle.
- Pedal may be locked in vertical position for storage or shipment.
- 1-1/4" diameter acme threaded screw has 26-1/4" of travel.

## FEATURES

## (Model 81035A)

- An adjustment pin chained to the stand secures the support column at 6 different height positions.
- Quick adjust spin handle with thrust bearing eliminates wear and provides ease of turning under load.
- 1-1/4" diameter acme threaded screw has 6-1/2" of travel for fine adjustment.
- 5/8" thick rubber saddle pad.

## FEATURES

## (Model 81036A)

- Foot activated pump and lowering pedals allow use of both hands to position components.
- Spring return lowering pedal automatically closes the release valve when foot is removed from pedal.
- 16" hydraulic travel.
- Telescopic support tube with nine height adjustments at 2-1/2" increments.
- A 12" diameter, 3/8" thick steel base provides added stability.
- Two 3" diameter wheels provide easy maneuvering of stand into work position or around the shop.

## FEATURES

- Supports a vehicle with or without tires.
- Allows FWD vehicle to be easily moved in the service bay when drive train has been removed.
- Universal design fits any car without the need for additional vehicle adapters.
- Quick and independent width and height adjustments. Fully adjustable outriggers to fit any vehicle frame width. Threaded lift saddles with rubber pads are independently adjustable and provide maximum frame protection.
- Does not require installation to the subframe or engine/transaxle cradle mounting holes.
- Can be used in pairs for maximum maneuverability in tight places.
- Four 6" diameter ball bearing mounted swivel caster wheels rated at 900 pounds capacity each.



MODEL NUMBER	CAPACITY	HEIGHT ADJUSTMENT	WIDTH	LENGTH ADJUSTMENT	SHIPPING WEIGHT
78090	3,600 lbs.	12.75" to 15.75"	17"	30" to 60"	65 lbs.

**The NORCO Difference:**  
 Smooth and easy operation

**NORCO MECHANICAL SCISSORS JACK**



## FEATURES

- Combination right and left hand threaded drive screw for faster rising.
- Includes 2-piece extra long 22.5" crank handle for easier operation under load, longer reach and convenient storage when not in use.

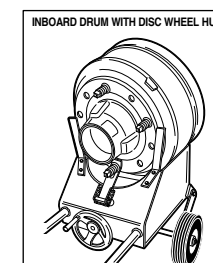
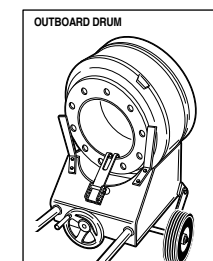

MODEL NUMBER	CAPACITY	LIFT HEIGHT		BASE DIMENSIONS	SADDLE SIZE	SHIPPING WEIGHT
		Low	High			
82002C	1-1/2 Ton	3.75"	13.25"	4.25" x 7.375"	2" x 5.125"	10 lbs.

82002C

1-1/2 TON  
SCISSORS JACK
*Passenger car tire changing.*

## FEATURES

- Reduces lost-time injuries.
- Handles 15" and 16-1/2" drums.
- 35-1/2" handle for easy positioning during installation & removal.
- Machine rotating handle provides ease of raising and lowering drum.
- 8" diameter ball bearing wheels, semi-pneumatic tires and 3/4" diameter axle provide easy maneuverability and balance of drum.
- Adjustable angle bracket secures both outboard and inboard mounted drums with disc wheel hubs to the drum handler's carriage.
- Detachable handle for convenient storage.



MODEL NUMBER	LIFT HEIGHT		OVERALL DIMENSIONS		SHIPPING WEIGHT
	Low	High	Length	Width	
72040B	10.25"	15.25"	62.5"	21"	64 lbs.

**NORCO BRAKE DRUM HANDLER**

72040B

## INTENDED USE

Designed for removing, installing and transporting outboard mounted brake drums and inboard mounted drums with disc wheel hubs.

**The NORCO Difference:**  
 Handles inboard & outboard drums

78090

## 3600 LBS. CAPACITY

## INTENDED USE

For easy movement of vehicles that have been rendered inoperable due to engine / transaxle removal or other mechanical problems. Frees up lifts and floor jacks for other work to be performed. Used in automobile repair, collision repair, and vehicle inspection applications.

## 79324F

3 TON CAPACITY  
AIR / HYDRAULIC  
PUMP OPERATED

## INTENDED USE

For use in conjunction with above ground lifts. The bridge straddles the lift rails and raises the vehicle's tires off the rails for wheel alignment, brake, tire and suspension work.



## FEATURES

- Push button air/hydraulic pump provides safe, quick lifting.
- The lifting pads safely support the vehicle on the bridge and the adjustable lift arms span up to 60".
- Universal mounting brackets adjust to a lift rail opening of 46-1/2".
- Flat-end and hook-end adapter brackets are equipped with spring-loaded roller bearings for smooth maneuverability of bridge on lift rails. These brackets are sold separately.
- Mechanical stop prevents accidental lowering of bridge.
- Lowering is accomplished with one hand on the release lever and the other hand releasing the mechanical stop.
- Equipped with rubber faced saddle for differential lifting.

MODEL NUMBER	CAPACITY @ 100 P.S.I.	LIFT HEIGHT	DIMENSIONS			SHIPPING WEIGHT
			Length	Width	Height	
<b>79324F</b>	<b>3 Ton</b>	Up to 8"	35"	19.5"	9.5"	290 lbs.

## 79327D

HOOK-END  
ADAPTER  
BRACKET KIT

enables the Rolling Lift Bridge to roll on the rails of the lift. Weight: 12 lbs. per set of 4.

## AIR LIFT JACK

## IMPORT 82999i

## 10 TON CAPACITY

## INTENDED USE

Truck and farm equipment dealer garages, heavy duty construction repair shops and bus company garages.

## FEATURES

- Three-way heavy duty air valve provides fine control when lifting or lowering a vehicle.
- Automatic safety lock engages in six different height positions independent of air pressure.
- Designed for lifting entire front or rear of a vehicle.
- Front swivel caster wheel and two 12-1/4" diameter pneumatic rear tires provide easy maneuverability.
- Adjustable lifting saddles can be raised and extended to desired position.



MODEL NUMBER	CAPACITY @200 P.S.I.	LIFT HEIGHT		OVERALL DIMENSIONS			SADDLE REACH	SHIPPING WEIGHT
		Low	High	Length	Width	Height		
<b>82999i</b>	<b>10 Ton</b>	12.83"	44.72"	40.59"	34.72"	67.75"	11.18"	792 lbs.

## The NORCO Difference:

Unique combination of adapters allows use on most drive-on four-post lifts or quick-lube pits

## 79328C

## 9" EXTENSION ADAPTERS

for use with light duty trucks, vans and 4x4's. The adapter increases the outer saddle height on the sliding lift rail from 1-1/4" to 10-1/2". Weight: 19 lbs. per pair.

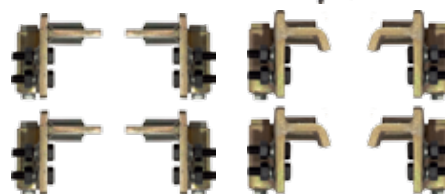
79326D  
SOLD IN KITS79327D  
SOLD IN KITS

## NOTE:

Adapter bracket kits must be ordered separately to adapt the universal mounting brackets to the above ground lift's rails. The majority of applications will require model 79326D flat-end or model 79327D hook-end adapter kits. Other kits are available upon request.



## The NORCO Difference:

The longest reach in the industry

## FEATURES

- Three-way heavy duty air valve provides fine control when lifting or lowering a vehicle.
- Automatic safety lock engages in five different height positions independent of air pressure.
- Includes extension tubes and adjustment pins for added height requirements.
- Two 10" diameter solid wheels are strategically located for better positioning and maneuverability.
- Scissors action frame design with four 5" diameter steel wheels provides maximum stability during lifting and lowering.
- Large air cylinder requires only 100 p.s.i. air pressure to lift 5 ton capacity.
- Over four feet of reach between cylinder and center line of lifting saddle.



MODEL NUMBER	CAPACITY	LIFT HEIGHT		OVERALL DIMENSIONS			SADDLE REACH	SHIPPING WEIGHT
		Low	High	Length	Width	Height		
<b>82995</b>	<b>5 Ton @ 100 P.S.I.</b> <b>7 Ton @ 150 P.S.I.</b> <b>8-1/2 Ton @ 180 P.S.I.</b>	10"	50"	80.5"	38"	53.75"	50"	935 lbs.

## The NORCO Difference:

Perfect for lifting trailers

## 82990C

## 10 TON CAPACITY

## INTENDED USE

Garages / repair shops of truck, farm equipment, construction equipment and bus companies. May be used in pairs. Ideal for crowded conditions that require single point contact.



MODEL NUMBER	CAPACITY @172 P.S.I.	LIFT HEIGHT		OVERALL DIMENSIONS			STROKE	SHIPPING WEIGHT
		Low	High	Length	Width	Height		
<b>82990C</b>	<b>10 Ton</b>	17.75"	49.375"	58"	13.625"	17.75"	11.5"	178 lbs.

**The NORCO Difference:**  
Inexpensive high quality engine support

**78099**

**700 LBS. CAPACITY  
4 POINT ENGINE  
SUPPORT TOOL**

**INTENDED USE**

The main transverse support bar mounts on the shock strut towers to support engines. Heavier engines can be supported by using one or both front support adapters on the transverse support bar. Weight: 52 Lbs.



**FEATURES**

- Fully adjustable strut tower mounts can be positioned on the transverse support bar up to 47-1/2" apart to fit most vehicles.
- Two front support adapters can mount directly onto the transverse support bar and easily be adjusted to fit any engine compartment configuration.
- Support bar and adapters are made of lightweight steel tubing, welded together in a parallel configuration to prevent flexing and provide full length positioning of the hooks and adapter front mounting feet.
- Three 1/2" diameter hooks 14" long and spin knobs provide strength and quick adjustment to support the engine.

**The NORCO Difference:**  
All-new tech friendly design

**72050E**

**1/2 TON CAPACITY**

**INTENDED USE**

For removal and installation of automobile and light truck transmissions or differentials.

**FEATURES**

- Wide chassis with open front provides:
  - Wider opening for saddle and transmission to come lower to the ground for easy removal.
  - Efficient load distribution and stability.
  - Easy access to saddle tilt knobs.
- Fully adjustable universal saddle with adjustable corner brackets and safety chain.
- Safety by-pass system prevents damage to cylinder.
- Safety overload system prevents jack from being used beyond its rated capacity.
- Full 360 degree rotating pump handle operates in any position.
- Flash chromed ram inhibits rust from entering the hydraulic system.
- Four full-swivel ball bearing caster wheels for easy positioning.
- Wide chassis for efficient load distribution and stability.



MODEL NUMBER	CAPACITY	LIFT HEIGHT		OVERALL DIMENSIONS		SADDLE SIZE	SHIPPING WEIGHT
		Low	High	Length	Width		
<b>72050E</b>	<b>1/2 Ton</b>	7.375"	32.125"	36"	26.5"	7.125" x 8.125"	152 lbs.



**NOTE: See optional adapters and saddles on page 18-19.**

**The NORCO Difference:**  
Designed with the service professional in mind

**FEATURES**

- Wide chassis with open front provides:
  - Wider opening for saddle and transmission to come lower to the ground for easy removal.
  - Efficient load distribution and stability.
  - Easy access to saddle tilt knobs.
- Fully adjustable universal saddle with adjustable arms to position the transmission.
- Heavy duty chain with convenient chain tensioner secures load to the saddle.
- Safety by-pass system prevents damage to the hydraulic cylinder.
- Safety overload system prevents jack from being used beyond its rated capacity.
- Full 360 degree rotating handle operates in any position.
- Flash chromed ram inhibits rust from entering the hydraulic system.
- Four 4" diameter full-swivel ball bearing caster wheels for easy positioning.



**72000E (shown)  
\*72000Ei**

**\*NOTE:**  
Model not shown has same basic construction as model pictured. Import model differs slightly from model made in U.S.A.

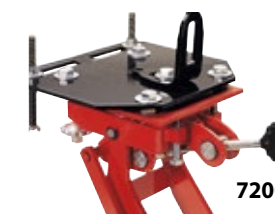

**72001**



**72003**

MODEL NUMBER	CAPACITY	LIFT HEIGHT		OVERALL DIMENSIONS		SADDLE SIZE	SHIPPING WEIGHT
		Low	High	Length	Width		
<b>72000E</b> <b>72000Ei</b>	<b>1-1/2 Ton</b>	7.75"	36.5"	45"	28"	10.25" x 15.25"	310 lbs.



**U.S. CONTENT** **72000E**

**IMPORT 72000Ei**

**1-1/2 TON CAPACITY**

**INTENDED USE**

For heavy truck transmissions. Ideally suited for truck dealers, maintenance and heavy duty transmission repair centers.

**OPTIONAL EQUIPMENT**

**U.S. CONTENT** **72001**

**DIFFERENTIAL ADAPTER**

is used with models 72000E, 72000Ei, 72700A and 72701A jacks only. Adapter fits most differentials and replaces the universal saddle when used. Weight: 29 lbs.

**U.S. CONTENT** **72003**

**FULLER® EATON® ROADRANGER® ADAPTER**

is used with models 72000E & 72000Ei jacks only. Weight: 21 lbs.

**The NORCO Difference:**  
Unique saddle handles the largest transmissions

**FEATURES**

- Fully adjustable saddle with adjustable angle brackets to position the transmission.
- Four 4" high risers handle transmissions with offset transfer cases.
- Two heavy duty ratchet tie-downs conveniently secure the load to the lifting saddle.
- Safety by-pass and overload systems to prevent cylinder damage and prevent the jack from being used beyond its rated capacity.
- Full 360 degree rotating handle operates in any position.
- Flash chromed ram inhibits rust from entering the hydraulic system.
- Four full-swivel ball bearing 4" caster wheels for easy positioning.



MODEL NUMBER	CAPACITY	LIFT HEIGHT		OVERALL DIMENSIONS			SADDLE SIZE	SHIPPING WEIGHT
		Low	High	Length	Width	Height		
<b>72025</b>	<b>1-1/2 Ton</b>	4.75"	36.5"	43.25"	32.75"	12"	18.25" x 15.25"	414 lbs.



**U.S. CONTENT** **72025**

**1-1/2 TON CAPACITY**

**INTENDED USE**

Same as the model 72000E but with a wider chassis opening plus a broader lift range to handle a larger variety of transmission configurations.



72675



**1,250 LBS. CAPACITY**

**INTENDED USE**

The Power Train Lift/Table not only handles transmissions and fuel tanks, but also engines and transaxles, rear ends and leaf springs. Also serves as a work table where the components can be lowered to a stable and secure work height for repair.



**FEATURES**

- An air/hydraulic foot pump includes a metered valve for safe lowering of the load.
- The pump can be removed from its holder, placed closer to the lift saddle, leaving hands free to accurately position the load.
- Fully adjustable saddle with two ratchet tie-downs secure the load to the saddle.
- Four swivel ball bearing caster wheels with polyurethane tread protect floors yet provide easy maneuverability.
- The rear caster wheels have a double locking feature. One lock prevents the rear wheels from turning when the lift is used in a repair mode. The other locks the rear casters in a fixed direction to provide steering ability.
- The optional model 72508 Fuel Tank Saddle Adapter (page 18) can quickly and easily be installed.

72850A



**2,500 LBS. CAPACITY**

**INTENDED USE**

This lift table handles power train components like engines and their transmissions, engines with trans-axle assemblies, rear ends and large electric vehicle batteries. It will also serve as a work table where components can be lowered to a convenient work height for repairs.



**FEATURES**

- An air/hydraulic foot pump includes a metered valve for safe lowering of the load.
- Five foot extension hose with quick disconnect fittings stores in the lift base. The foot pump can be removed from its holder and hydraulic hose quickly and easily extended by 5' using the extension hose. This provides hands free operation of the pump anywhere around the lift's perimeter.
- Scissors lift design provides easy 360° access to any component.
- Two heavy duty ratchet tie-downs are included to safely secure the load on the lift table.
- Table top height from 31" to 80-1/2".
- Four 8" diameter swivel caster wheels for easy maneuverability. Front wheels can be locked in position for steering. Rear wheels can be locked to prevent the lift from rolling.



MODEL NUMBER	CAPACITY @100 P.S.I.	LIFT HEIGHT		OVERALL DIMENSIONS			TABLE SIZE	SHIPPING WEIGHT
		Low	High	Length	Width	Height		
<b>72675</b>	<b>1,250 lbs.</b>	30"	77"	65"	43"	51.25"	14" x 31"	480 lbs.
<b>72850A</b>	<b>2,500 lbs.</b>	31"	78"	50"	33"	35"	19" x 36"	665 lbs.

72700A

**1 TON CAPACITY**

**INTENDED USE**

Designed for the removal, installation and transportation (in the lowered position) of heavy duty truck transmissions that are raised by an in-ground or above-ground lift.



**FEATURES**

- Fully adjustable universal saddle with adjustable corner brackets and safety chain.
- Safety overload system prevents jack from being used beyond its rated capacity.
- 2" diameter, flash chromed, single stage ram provides added stability throughout the entire lift range.
- Foot operated pump and lowering pedals allow use of both hands to position and align saddle with transmission.
- Wide base with four 3-7/8" diameter heavy duty swivel ball bearing caster wheels provides stability and easy maneuvering.

**NOTE: See optional adapters and saddles on pages 13 & 18.**

MODEL NUMBER	CAPACITY	LIFT HEIGHT		BASE DIMENSIONS	SHIPPING WEIGHT
		Low	High		
<b>72700A</b>	<b>1 Ton</b>	45.75"	74.25"	38" x 38"	292 lbs.

**The NORCO Difference:**  
Maneuverability and stability for safe transmission service

**FEATURES**

- Air/hydraulic foot pump provides hands free operation and easy convenient lifting.
- Metered pump valve provides safe lowering of load.
- Fully adjustable universal saddle with adjustable arms to position the transmission.
- Heavy duty chain with convenient chain tensioner secures load to saddle.
- 2" diameter, flash chromed, single stage ram provides added stability throughout the entire lift range.
- Wide base with four 3-7/8" diameter heavy duty swivel ball bearing caster wheels provides stability and easy maneuvering.

**NOTE: See optional adapters and saddles on pages 13 & 18.**

MODEL NUMBER	CAPACITY @100 P.S.I.	LIFT HEIGHT		BASE DIMENSIONS	SHIPPING WEIGHT
		Low	High		
<b>72701A</b>	<b>1 Ton</b>	41.25"	69.375"	37.5" x 38"	273 lbs.

72701A

**1 TON CAPACITY AIR/HYDRAULIC**

**INTENDED USE**

Same as the model 72700A but with the added convenience of an air/hydraulic foot pump.



**The NORCO Difference:**  
The widest variety of transmission  
jacks on the market

**72500E**

### TELESCOPIC 1/2 TON CAPACITY SINGLE PUMP

**INTENDED USE**

Designed for the removal, installation and transportation (in the lowered position) of transmissions and transfer cases on passenger cars, vans and light trucks that are raised by an in-ground or above-ground lift.

**FEATURES**

- Fully adjustable universal saddle with hand adjustable corner brackets and safety chain.
- Safety overload system prevents jack from being used beyond its rated capacity.
- Foot operated pump and lowering pedals allow use of both hands to position and align saddle with transmission.
- Two-stage flash chromed rams inhibit rust from entering hydraulic system.
- Wide base with four easy rolling 4" diameter swivel ball bearing caster wheels, provides stability and easy maneuvering in its lowered position.
- Polyurethane wheels provide protection for expensive tile and epoxy floors.

MODEL NUMBER	CAPACITY	LIFT HEIGHT		BASE DIMENSIONS	SHIPPING WEIGHT
		Low	High		
<b>72500E</b>	1/2 Ton	35"	72"	34" x 37"	176 lbs.

**The NORCO Difference:**

The economy of manual operation with the speed of air models

**NOTE: See optional adapters and saddles on pages 18-19.**

**72550B FASTJACK**

### TELESCOPIC 1/2 TON CAPACITY DOUBLE PUMP

**INTENDED USE**

Designed for the removal, installation and transportation (in the lowered position) of transmissions and transfer cases on passenger cars, vans and light trucks that are raised by an in-ground or above-ground lift.

**FEATURES**

- Fully adjustable universal saddle with hand adjustable corner brackets and safety chain.
- Safety overload system prevents jack from being used beyond its rated capacity.
- Foot operated pump and lowering pedals allow use of both hands to position and align saddle with transmission.
- Two-stage flash chromed rams inhibit rust from entering hydraulic system.
- Wide base with four easy rolling 4" diameter swivel ball bearing caster wheels, provides stability and easy maneuvering in its lowered position.
- Two times faster rising action as model 72500E with no load or a load up to 400 pounds.
- Same rising action as model 72500E for loads between 400 and 1,000 pounds.
- Polyurethane wheels provide protection for expensive tile and epoxy floors.

**U.S. PATENT NO. 5,975,496**  
(Double Pump Design)

MODEL NUMBER	CAPACITY	LIFT HEIGHT		BASE DIMENSIONS	SHIPPING WEIGHT
		Low	High		
<b>72550B</b>	1/2 Ton	35"	72"	34" x 37"	178 lbs.

**FASTJACK 72450B**

### TELESCOPIC 1/2 TON CAPACITY AIR/HYDRAULIC

**INTENDED USE**

Designed for the removal, installation and transportation (in the lowered position) of transmissions and transfer cases on passenger cars, vans and light trucks that are raised by an in-ground or above-ground lift.

**U.S. PATENT NO. 7,171,807**

MODEL NUMBER	CAPACITY	LIFT HEIGHT		BASE DIMENSIONS	SHIPPING WEIGHT
		Low	High		
<b>72450B</b>	1/2 Ton	36"	75"	34" x 34"	175 lbs.

**FEATURES**

- Air/hydraulic foot pump provides hands free operation and easy, convenient lifting.
- Metered pump valve provides safe lowering of load.
- Fully adjustable universal saddle with hand adjustable corner brackets and safety chain.
- Safety overload system prevents jack from being used beyond its rated capacity.
- Two-stage flash chromed rams inhibit rust from entering hydraulic system.
- Wide base with four easy rolling 4" diameter polyurethane, swivel ball bearing caster wheels (one is a locking caster wheel) provides stability and easy maneuvering in its lowered position.
- Polyurethane wheels provide protection for expensive tile and epoxy floors.

**NOTE: See optional adapters and saddles on pages 18-19.**

**The NORCO Difference:**

Simultaneous operation of two-stage ram for speedy transmission repair

**FEATURES**

- Air/hydraulic foot pump provides hands free operation and easy, convenient lifting.
- Metered pump valve provides safe lowering of load.
- Fully adjustable universal saddle with hand adjustable corner brackets and safety chain.
- Safety overload system prevents jack from being used beyond its rated capacity.
- Two-stage flash chromed rams inhibit rust from entering hydraulic system.
- Wide base with four easy rolling 4" diameter polyurethane, swivel ball bearing caster wheels (two are locking caster wheels) provides stability and easy maneuvering in its lowered position.
- Comes with a larger 10-1/4" x 15-1/8" saddle plate and four adjustable "L"-shaped locating bars.
- Polyurethane wheels provide protection for expensive tile and epoxy floors.

**FASTJACK 72475A**

### TELESCOPIC 3/4 TON CAPACITY AIR / HYDRAULIC

**INTENDED USE**

Designed for the removal, installation and transportation (in the lowered position) of transmissions and transfer cases on passenger cars and up to one ton capacity vans and trucks that are raised by an in-ground or above-ground lift.

**U.S. PATENT NO. 7,171,807**

MODEL NUMBER	CAPACITY	LIFT HEIGHT		BASE DIMENSIONS	SHIPPING WEIGHT
		Low	High		
<b>72475A</b>	3/4 Ton	36.5"	75.25"	36" x 36"	196 lbs.



For use with all NORCO floor and under hoist transmission jacks.

72531

**AUTOMOTIVE TO HEAVY DUTY SADDLE ADAPTER****INTENDED USE**

Allows any automotive adapter to be attached to any heavy duty under hoist transmission jack. Weight: 18 lbs.



72531

**The NORCO Difference:**

Unique vehicle & service specific adapters save time and enhance safety

This unique adapter allows any NORCO automotive transmission saddle adapter to be used with the NORCO heavy duty transmission jacks: 72700A or 72701A. This economical design can save a shop thousands of dollars by allowing one transmission jack to be used for both heavy duty truck and automotive applications.

72514

**MERCEDES 722 ADAPTER****INTENDED USE**

For use on Mercedes #722 transmissions. Weight: 12 lbs.



72514

An optional saddle adapter which is used in conjunction with a NORCO under hoist transmission jack to remove, install and transport (in the lowered position) later model Mercedes 722 transmissions.

72508

**FUEL TANK SADDLE****INTENDED USE**

An optional saddle adapter which is used in conjunction with a NORCO transmission jack to remove, install and transport (in the lowered position) automobile and light truck emptied fuel tanks and other undercar components. Weight: 37 lbs.

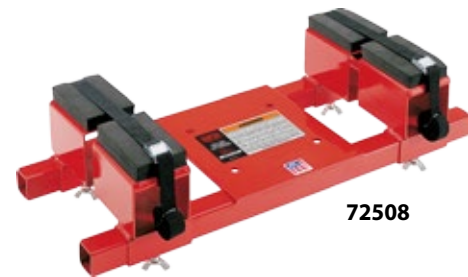

72508

**FEATURES**

- Handles automotive and light duty truck fuel tanks up to 40 gallon capacity. Tanks are to be emptied before handling.
- Four adjustable support risers with rubber pads protect the fuel tank and can be quickly positioned to fit many shapes and sizes.
- Includes two load restraint straps.

72525

**QUICK-ADJUST SADDLE****INTENDED USE**

An optional saddle that replaces the 4 adjustable corner brackets found on the standard universal saddle. Weight: 19 lbs.



72525

**FEATURES**

- Quickly adapts to the existing universal saddle plate.
- Four low profile ratcheting arms quickly and easily adjust to the transmission pan configuration.

72529



Diesel Exhaust Adapter for F-250, 350, 450, 550 Super Duty with a 6.7L Diesel. Weight: 42 lbs.



72529

72034

**CLUTCH SADDLE 300 LBS. CAPACITY****INTENDED USE**

An optional saddle adapter which is used in conjunction with all NORCO under hoist transmission jacks (pages 16-17). Weight: 22 lbs.



72034

For use with all NORCO floor and under hoist transmission jacks.



72509

For use on Ford 5R55W, 4R70W, AX4N, AXOD METRIC transmissions. This one adapter can quickly and easily be adjusted to fit four different transmission configurations. Weight: 38 lbs.



72509



72004

For use on Ford 6R140 Transmissions. Weight: 32 lbs.

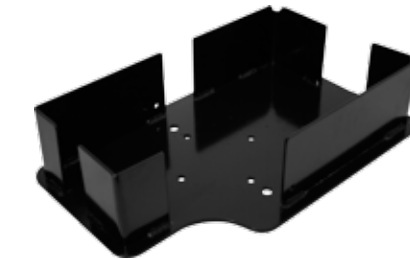

72004

**CD4E VEHICLE APPLICATIONS:**

1994–2002 Mazda 626 4-cylinder  
1994–1997 Mazda MX-6 4-cylinder  
1994–1997 Ford Probe 4-cylinder  
1995–2000 Ford Contour  
1995–2000 Mercury Mystique  
1995–2007 Ford Mondeo (up to Mondeo III 4 cylinder model)  
1999–2002 Mercury Cougar  
2001–2007 Ford Escape  
2001–2006 Mazda Tribute  
2005–2007 Mercury Mariner



72513



72513

For use on Ford CD4E transmissions. Weight: 17 lbs.

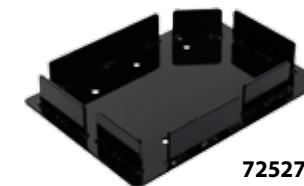

72527

**4F27E VEHICLE APPLICATIONS:**

Ford EcoSport with 2.0L Duratec engine  
Ford Focus with 2.0L Zetec engine & 2.3L Duratec engine  
Ford Fiesta 2008+, with 1.4L, 96hp engine  
Mazda Protegé  
Mazda3  
Mazda6



72527

For use on Ford 4F27E transmissions. Weight: 15 lbs.

**6R80 VEHICLE APPLICATIONS:**

2008–2010 Ford Expedition  
2008–2010 Lincoln Navigator  
2008–2010 Ford Explorer  
2007–2010 Ford Explorer Sport Trac  
2008–2010 Mercury Mountaineer  
2009–2012 Ford F-150  
2011 Ford Territory (SZ-series TCDi model)  
2011–2012 Ford Mustang V6, GT



72528



72528

For use on Ford 6R80 transmissions. Weight: 24 lbs.



72512

For use on Ford and Lincoln 6F50 and GM 4T60E transmissions. Weight: 25 lbs.

72507B



For use on Ford E40D, 5R110 and 4R100 truck transmissions. F250 - F550 Super Duty. Weight: 35 lbs.



72507B



72512



**72035****300 LBS. CAPACITY  
TELESCOPIC  
UNDER HOIST  
AIR / HYDRAULIC****INTENDED USE**

Designed for the removal, installation and transportation (in the lowered position) of 14" and 15-1/2" heavy duty clutches and flywheels on trucks that are raised by an in-ground or above-ground lift.

**FEATURES**

- Tilting saddle activated by an integrated screw with machine handle enables the clutch to be positioned in either a horizontal position for clearing underneath truck or vertical position for installation and removal.
- 2" and 1-3/4" diameter spline shafts rotate 360° for clutch and engine alignment.
- Air/hydraulic foot pump provides hands free operation and easy, convenient lifting.
- Metered pump provides safe lowering of load.
- Two-stage flash chromed rams inhibit rust from entering hydraulic system.
- Polyurethane wheels provide protection for tile and epoxy floors.

U.S. PATENT NO. 7,171,807

MODEL NUMBER	CAPACITY	LIFT HEIGHT		BASE DIMENSIONS	SHIPPING WEIGHT
		Low	High		
<b>72035</b>	<b>300 lbs.</b>	38.25"	73.5"	35" x 35"	159 lbs.

**The NORCO Difference:**

Allows for easy clutch repair with or without a lift

**72030B****300 LBS. CAPACITY  
FLOOR MODEL TYPE  
HYDRAULIC****INTENDED USE**

To remove, install and transport (in the lowered position) both 14" and 15-1/2" heavy duty clutches and flywheels.

**FEATURES**

- Clutch/flywheel removal and installation becomes a one man job.
- Tilting saddle enables clutch to be positioned in either horizontal position for clearing underneath truck or vertical position for installation and removal.
- Adjustment bolt on saddle aligns clutch and flywheel.
- Spline shaft rotates 360 degrees, turns left and right for clutch and engine alignment. 2" and 1-3/4" spline shafts included.
- Conveniently located release valve and 360 degree rotating pump handle allow jack to be operated in any work position.

**OPTIONAL EQUIPMENT  
for models 72030B and 72035****72033****FLYWHEEL ADAPTER**  
Weight: 7 lbs.

MODEL NUMBER	CAPACITY	LIFT HEIGHT		OVERALL DIMENSIONS		SHIPPING WEIGHT
		Low	High	Length	Width	
<b>72030B</b>	<b>300 lbs.</b>	11.5"	37.75"	35"	26.5"	148 lbs.



**The NORCO Difference:**  
The most innovative saddle!

**72036C****5 TON CAPACITY  
@ SCISSORS END  
AND POST****INTENDED USE**

A versatile jack having a low enough profile to raise forklifts and a high enough profile to raise farm equipment, tractors and some earthmoving equipment.

**FEATURES**

- Two lift points (saddle & post) for numerous lifting applications.
- Two-position saddle at scissors end can be quickly rotated to handle either edges or flat surfaces of a load.
- 2-1/2" low lift height at scissors end.
- 30" removable handle for ease of pumping and storage when not in use.
- Metered release mechanism provides slow, controlled lowering of the load.
- Safety overload valve prevents jack from being used beyond its rated capacity.

**TWO-POSITION SADDLE @ SCISSORS END**

Lifts at edge

Lifts flat surfaces



MODEL NUMBER	CAPACITY	LIFT HEIGHT				OVERALL DIMENSIONS		SHIPPING WEIGHT
		POST Low	POST High	SCISSORS Low	SCISSORS High	Length	Width	
<b>72036C</b>	<b>5 Ton</b>	17.375"	31"	2.5"	18.25"	30.25"	8.375"	104 lbs.

**The NORCO Difference:**  
The most economical tire lever

**NORCO** TIRE DOLLIES**82310****NARROW SINGLE TIRE  
HANDLER DOLLY****82312****WIDE SINGLE TIRE  
HANDLER DOLLY****INTENDED USE**

To provide added leverage to easily remove or install truck tire-and-wheel assemblies.

**FEATURES**

- Heavy-duty tubular steel construction capable of handling 300 pounds.
- Easy grip handle along with improved "bent arm" design improves leverage for easier installation and minimizes back strain.
- Steel alignment rollers allow simple alignment of the wheel to the wheel studs.
- Spring-loaded kickstand offers convenient storage.
- Two models capable of handling tire diameters from 24 to 48 inches.



82310

82312

MODEL NUMBER	HANDLES TIRES	OVERALL DIMENSIONS		SHIPPING WEIGHT
		Length	Width	
<b>82310</b>	<b>24" - 36"</b>	42.5"	24.75"	19 lbs.
<b>82312</b>	<b>36" - 48"</b>	41"	32"	22 lbs.



**82302B** **1/2 TON CAPACITY**

**INTENDED USE**  
For the removal and installation of single, tandem and duplex tires and wheels which are mounted on trucks that are supported above ground level.

**The NORCO Difference:**  
Side-shift feature makes for easy wheel alignment

**82304** **1/2 TON CAPACITY AIR/HYDRAULIC**

**INTENDED USE**  
This uniquely crafted wheel lift is designed for the removal and installation of single, tandem, and duplex tires and wheels which are mounted on trucks that are supported above ground level.

**FEATURES**

- Heavy duty lift arms made with ball bearing conveyer rollers which allow easy rotation of wheels for alignment with bolt pattern.
- 7-1/2" of side to side lift arm adjustment eliminates the trial and error method of aligning the rim's lug holes with the wheel drum.
- A 1,500 pound capacity heavy duty winch with 5 to 1 gear ratio provides ease of operation.
- The winch gear design acts as a brake and allows the load to be lowered incrementally if desired and without the need for constant hand pressure against the crank handle.
- A hydraulic jack tilts the lift arms to match the angle of the spindle.
- Safety chain provided to secure tires and wheels to the dolly.
- Maneuverability is made easy by means of two rear mounted ball bearing caster wheels. The caster wheels include a locking mechanism which can prevent the dolly from moving.



**FEATURES**

- The unique, open-chassis design allows for much easier alignment than with the center post designs of our competition.
- Air-operated pump allows the unit to lift the load effortlessly.
- Heavy duty lift arms made with ball bearing conveyer rollers which allow easy rotation of wheels for alignment with bolt pattern.
- 39-1/2" lift range.
- 7" of side to side lift arm adjustment allows for the easy alignment of the rim's lug holes with the wheel.
- 1,000 pound capacity.
- A hydraulic jack provides tilt to the lift arms for easy alignment.
- Safety chain provided to secure tires and wheels to the dolly.
- Maneuverability is made easy by means of two rear mounted ball bearing swivel casters. The caster wheels include a locking mechanism which can prevent the dolly from moving.



MODEL NUMBER	CAPACITY	LIFT HEIGHT		LIFT ARMS			SIDE TO SIDE ADJ.		OVERALL DIMENSIONS			SHIPPING WEIGHT
		LOW	HIGH	WIDTH	LENGTH	TILT ANGLE	LEFT	RIGHT	L	W	H	
<b>82302B</b>	<b>1/2 Ton</b>	3"	41.25"	24.25"	21"	-2° to +30°	3.25"	4.25"	45.75"	43.75"	62"	315 lbs.
<b>82304</b>	<b>1/2 Ton</b>	2.125"	39.5"	30.875"	22.125"	-2° to +30°	2.5"	4.5"	49.625"	44.625"	69.875"	476 lbs.



**TIRE LIFTER** **NORCO**

**82305** **300 LB. CAPACITY SINGLE TIRE LIFTER**

**INTENDED USE**  
To safely assist a technician with the removal and installation of single wheels on vehicles that are supported on a lift.



**FEATURES**

- Maneuverability is made easy by means of four swivel caster wheels. Two rear caster wheels include a locking mechanism which can prevent the dolly from moving.
- Unique offset design offers open access from the rear to mount wheel to the vehicle.
- Onboard rollers make for easy stud-to-hole alignment.
- Air-operated pump allows the unit to lift the load effortlessly.
- 6-1/4" low height of support legs.



MODEL NUMBER	CAPACITY	LIFT TRAVEL	LIFT ARMS			OVERALL DIMENSIONS			SHIPPING WEIGHT	
			LOW HT.	HIGH HT.	WIDTH	LENGTH	L	W		H
<b>82305</b>	<b>300 lbs.</b>	51"	2"	53"	20" I.D. / 24" O.D.	17.5"	39"	31.75"	79"	215 lbs.

**The NORCO Difference:**  
Designed and built in America

**82300D** **1 TON CAPACITY**

**82301D** **1 TON CAPACITY**

**INTENDED USE**  
For the removal and installation of single, tandem and duplex tires and wheels.

**FEATURES**

- Rear swivel caster wheel and rigid front wheels provide positive steering for the model 82300D. Swivel caster wheels both fore and aft provide side to side maneuverability for the model 82301D.
- 4" wheels with polyurethane tread protect floor.
- Lift arms can be adjusted in closer to handle the more common dual wheel combinations and then adjusted outward to handle the larger combinations.
- Lift arms with ball bearing rollers easily rotate vehicle rim for bolt pattern alignment.
- Lift arms supported at both ends minimize wheel movement.
- Adjustable height push bar provides unobstructed access to hub area.
- 3-1/4" travel adjustment on rear caster wheel matches lifting arms with spindle angle.
- Safety chain included to secure wheel assembly to dolly during removal and transport.

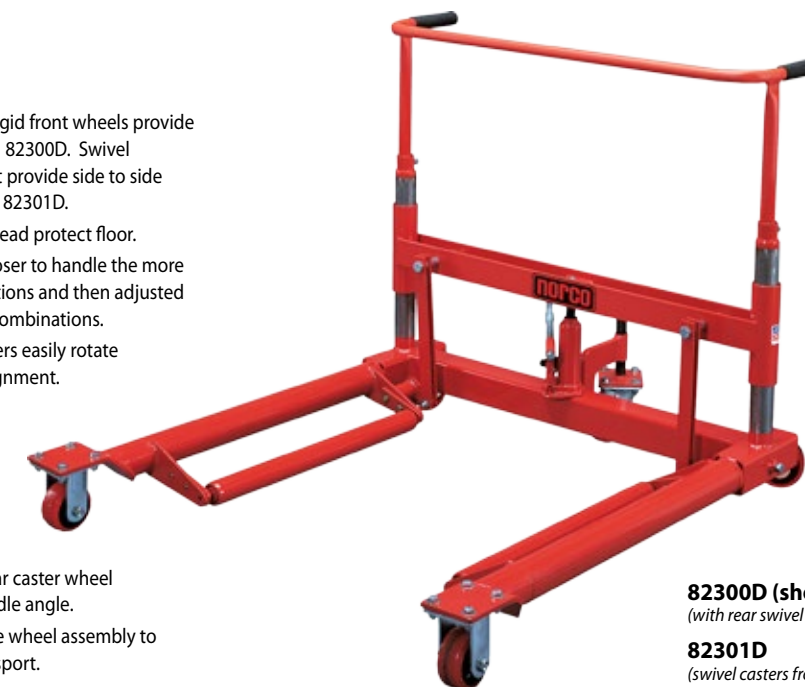

**82300D (shown)**  
(with rear swivel caster)

**82301D**  
(swivel casters front & rear)  
(1 TON)



MODEL NUMBER	CAPACITY	LIFT TRAVEL	OVERALL DIMENSIONS			SHIPPING WEIGHT
			Length	Width	Height	
<b>82300D</b>	<b>1 Ton</b>	7.5"	50.5"	44.5"	39"	207 lbs.
<b>82301D</b>	<b>1 Ton</b>	7.5"	50.5"	44.5"	39"	209 lbs.

**FEATURES**

- Dolly handles any tire diameter and up to 1,500 lbs. combined tire and wheel weight.
- Three 4" diameter swivel ball bearing caster wheels provide easy maneuverability & positioning.
- Travel adjustment on rear locking caster wheel matches lifting arms with spindle angle.
- 6' chain included to secure wheel assembly to dolly during removal & transport.
- Quick disconnect push/pull handle provides unobstructed access to hub area.



**82320** **3/4 TON CAPACITY**

**INTENDED USE**  
For the removal and installation of single, tandem and duplex tires and wheels.



MODEL NUMBER	CAPACITY	LIFT TRAVEL	LIFT ARMS		OVERALL DIMENSIONS			SHIPPING WEIGHT
			SPREAD	LENGTH	L	W	H	
<b>82320</b>	<b>3/4 Ton</b>	4.75"	26"	24.5"	43.5"	39.5"	35"	175 lbs.

**78106A**   
**FOLDABLE ENGINE CRANE**  
**2,500 LBS. CAPACITY**

**INTENDED USE**  
 Designed to raise, lower and transport automobile engines, transmissions, differentials and other heavy loads with minimal effort.

**FEATURES**

- Four position telescopic boom with 3/8" proof chain and swivel mounted hook.
- 3 ton capacity hydraulic power unit provides faster raising action and a large diameter ram to withstand angle loads.
- Low profile design (4-3/4" from top of legs to ground) allows positioning under low ground clearance vehicles.
- Quick foldable legs and boom save shop space (22-1/2" x 51-3/4") and prepare crane for transport or storage within seconds.
- 4" diameter front wheels and locking rear caster wheels provide positive steering and easy maneuvering. Locking caster wheels secure crane from moving when in use.



**Folded Position**

**78204A**   
**1/2 TON CAPACITY TRUCK CRANE**

**INTENDED USE**  
 Same as the model 78106A but mounts in the bed of a truck or on a loading dock.



**FEATURES**

- Four position telescopic boom that folds down for traveling position or storage.
- 5 to 1 gear ratio winch with 20 foot long 1/4" diameter steel cable and hook pulls the load toward the boom.
- Winch gear design acts as a brake and allows the load to be lowered incrementally if desired and without the need for constant hand pressure against the crank handle.
- Hydraulically activated boom lifts the load to the desired height.
- Crane swivels 360 degrees but can be locked in position.

**The NORCO Difference:**  
 Designed and built in America

**78600B**   
**3 TON CAPACITY AIR/HYDRAULIC FLOOR CRANE**

**78605A**   
**3 TON CAPACITY ELECTRO/HYDRAULIC FLOOR CRANE**

**INTENDED USE**  
 For lifting heavy items including removal and installation of diesel engines and often their transmissions.

**FEATURES**

- Multiple boom positions and leg extensions ranging from 49" to 81" provide maximum stability.
- Boom swivels 10 degrees right or left if base cannot be centered under the load.
- Floor lock secures crane from moving when in use.
- Model 78600B includes a foot activated air/hydraulic foot pump requiring 100 P.S.I. air pressure.
- Model 78605A includes an electro/hydraulic pump requiring 115 VAC.

**NOTE:**  
 See information concerning air and electro/hydraulic pumps on page 37.

\*Model not shown has same basic construction as model pictured.



**\*78600B  
 78605A (shown)  
 (3 TON)**

MODEL NUMBER	BOOM CAPACITY @ LENGTH	BOOM HEIGHT		OVERALL DIMENSIONS			SHIPPING WEIGHT
		Min.	Max.	Height	Width	Length	
<b>78106A</b>	<b>2,500 lbs. @ 43"</b>	0"	88"	70.75"	51.75"	74.5"	320 lbs.
<b>78204A</b>	<b>1/2 Ton @ 46.25"</b>	0"	68.5"	64"	14"	46.25"	180 lbs.
<b>78600B</b>	<b>3 Ton @ 65"</b>	13"	149.5"	90.5"	51"	75"	1,150 lbs.
<b>78605A</b>	<b>2 Ton @ 97"</b>	13"	149.5"	90.5"	51"	75"	1,182 lbs.



**The NORCO Difference:**  
 Increased technician safety by leveling the load



**78115**  
 (1,500 LBS.)

**FEATURES**

- Designed to hook to a crane or hoist to handle and position large, bulky components.
- The horizontal tilt can be adjusted to compensate for off-center loads, or adjusted to a certain angle for a component being positioned.
- Large adjustment handle allows for quick and easy leveling of the load.
- Can be used with NORCO Model 78106A Engine Crane.



**78606**  
 (6,000 LBS.)

**FEATURES**

- Designed to hook to a crane or hoist to handle and position large, bulky components.
- The horizontal tilt can be adjusted to compensate for off-center loads, or adjusted to a certain angle for a component being positioned.
- Adjustment screw can be used manually or with air tools.
- Can be used with NORCO Model 78600B or 78605A Engine Cranes.
- 5/16" Alloy Grade 80 chain.
- Position of hooks adjusts from 32" to 48".

**78115**  
**1,500 LB. CAPACITY ENGINE LOAD LEVELER**

**INTENDED USE**  
 Designed to attach to a crane to position automobile and light truck engines and other vehicle components.

**78606**   
**6,000 LB. CAPACITY ENGINE LOAD LEVELER**

**INTENDED USE**  
 Designed to attach to a crane to position heavy duty truck engines and other vehicle components.



MODEL NUMBER	CAPACITY	OVERALL DIMENSIONS			CHAIN LENGTH	SHIPPING WEIGHT
		Length	Width	Height		
<b>78115</b>	<b>1,500 lbs.</b>	28.25"	2.375"	8.125"	27"	20 lbs.
<b>78606</b>	<b>6,000 lbs.</b>	32.187"	5"	15.625"	26.875"	69 lbs.

**OPTIONAL EQUIPMENT**

**78109**   
**TRANSMISSION ADAPTER**

replaces engine mounting fingers and converts engine stand into a transmission service stand.  
 Weight: 11Lbs.



**FEATURES (78108 / 78108i)**

- Same as the models 78100 and 78100i but with upgraded wheels which include locking front caster wheels.
- Four bolts disassemble stand for transporting or storage.

**FEATURES (78100 / 78100i)**

- Fully adjustable engine mounting head.
- Long handle and 360 degree rotating head easily position engine.
- One bolt disassembles stand for transporting or storage.
- Heavy wall tubing prevents excessive frame flex.
- 2 rigid wheels in back and 2 swivel caster wheels in front provide maximum stability and support.



**78108  
 78108i**  
 (1,250 LBS.)

**78100  
 78100i**  
 (1,000 LBS.)



MODEL NUMBER	CAPACITY	OVERALL DIMENSIONS			FINGER ADJUSTMENT		SHIPPING WEIGHT
		Length	Width	Height	Height	Width	
<b>78100</b> <b>78100i</b>	<b>1,000 lbs.</b>	37"	34.5"	38"	12"-15.5"	15"-18"	87 lbs.
<b>78108</b> <b>78108i</b>	<b>1,250 lbs.</b>	39"	36.5"	39"	12"-15.5"	15"-18"	115 lbs.

**NORCO** ENGINE STANDS

**The NORCO Difference:**  
 A choice of USA made or import stands

**78100**   
**IMPORT 78100i**  
**1,000 LBS. CAPACITY ENGINE STAND**

**INTENDED USE**  
 For safe handling and positioning of most automotive engines.

**78108**   
**IMPORT 78108i**  
**1,250 LBS. CAPACITY ENGINE STAND**

**INTENDED USE**  
 Same as models 78100 and 78100i but with heavier construction to handle the largest V8s.

**The NORCO Difference:**  
Gear-driven 360 degree rotation  
makes for easier repairs

**78200A**  
**2,000 LBS. CAPACITY ENGINE STAND**

**INTENDED USE**  
A twin-post design capable of handling large automotive engines and small diesel engines ranging between 1,250 and 2,000 pounds.



**FEATURES**

- Includes two universal mounting plates, rotating shaft, eight fully adjustable arms and all the related mounting hardware.
- Rotating shaft with mounting plate telescopes inside the post receiver for fine adjustment when mounting ends or sides of engines. Mounting plates can be adjusted 36-1/4" apart.



Shown with optional 78201 engine adapters.

**OPTIONAL ENGINE MOUNTING ADAPTERS (FOR MODEL 78200A)**

**MODEL 78201**

Ford 6.0L and 6.4L Engine Adapter for 78200A  
Weight: 31 lbs.



**MODEL 78202**

Ford 6.2L Engine Adapter for 78200A  
Weight: 37 lbs.



**MODEL 78203**

Ford 6.7L Engine Adapter for 78200A  
Weight: 37 lbs.



**78125A**  
**1,250 LBS. CAPACITY ENGINE STAND**

**INTENDED USE**  
For safe handling and positioning of automotive engines weighing up to 1,250 pounds.

**FEATURES**

- 50:1 ratio gearbox activated by hand crank easily turns the 360 degree rotating head to the desired work position.
- Fully adjustable engine mounting head.
- Two rigid wheels in back and two swivel caster wheels in front provide maximum stability and support. One locking caster wheel secures the stand in the desired work location.
- Telescopic base locks into any one of four different positions to extend the length of the stand for added stability when required.



MODEL NUMBER	CAPACITY	HEIGHT	WIDTH		LENGTH		SHIPPING WEIGHT
			Front	Rear	From	To	
<b>78125A</b>	<b>1,250 lbs.</b>	42"	21.25"	40"	38.25"	53.25"	179 lbs.
<b>78200A</b>	<b>2,000 lbs.</b>	42"	21.25"	40"	38.25"	53.25"	289 lbs.



**The NORCO Difference:**  
Gear-driven 360 degree rotation  
makes for easier repairs



78160

**3 TON CAPACITY DIESEL ENGINE STAND**

**INTENDED USE**  
For safe handling and positioning of most diesel engines.



**FEATURES**

- Mounting head tilts for engine clearance in 360 degree rotation.
- 95 to 1 worm gear drive and long handle provide easy engine rotation.
- Floor lock keeps stand from moving during repairs.
- Universal adapter included.
- Optional adapters available.













MODEL NUMBER	CAPACITY	OVERALL DIMENSIONS			WHEEL DIAMETERS		ROTATIONAL CLEARANCE FROM MTG. HEAD TO GROUND	SHIPPING WEIGHT
		Length	Width	Height	Front	Rear		
<b>78160</b>	<b>3 Ton</b>	54.25"	50"	45"	7"	5.75"	35.25" to 43.25"	631 lbs.



**OPTIONAL ENGINE AND TRANSMISSION MOUNTING ADAPTERS**



- 78162:** Detroit Diesel Engine Adapter for 53, 71, and 92 Series Engines.
- 78163:** Cummins Engine Adapter for a Wide Range of Cummins Engines Including: NH, NTC, NTE, N14 855, V6 378; 504, 555, and V8 903; In-Line 6 KT 1150M. L10 (Now ISL).
- 78164:** Caterpillar Engine Adapter for In-Line 6 models: 1673, 1674, 1693, 3306, & 3406 engines. V8 models: 1100, 3208, and 3408.
- 78165:** IH and Ford Engine Adapter for International Harvester engines: DT-466 In-Line 6 DV-550, MV-404, MV-446, V304, V435, V392, 4-152, 4-194, 4-196, 9.0 liter V8. Ford 6.9L and 7.3L Engines.
- 78166:** Mack Engine Adapter for the following In-Line Six Cylinder Engine Series: 672, 673, 675, 711.
- 78167:** Detroit Allison Transmission Adapter for AT, MT, VS, VH, and V730.
- 78168:** Detroit Diesel Engine Adapter for V6 and V8, Series 71 Engines.
- 78169:** Caterpillar Engine Adapter for 3114, 3116, 3176 (Truck or Marine).
- 78170:** Mack Engine Adapter for V8 1000, E6 and E7 In-Line 6 Cylinder Engines.
- 78172:** Volvo Engine Adapter for TD67 (developed 1964), TD71 (developed 1984) Engines.
- 78173:** Detroit Allison Transmission Adapter for HT740D, HT750, HT750CT, CLBT, CR/DR.
- 78174:** Ford New Holland Adapter for 6.6L and 7.8L Engines.

 <b>78162</b> 65 lbs.	 <b>78163</b> 53 lbs.	 <b>78164</b> 77 lbs.	 <b>78165</b> 66 lbs.
 <b>78166</b> 56 lbs.	 <b>78167</b> 27 lbs.	 <b>78168</b> 55 lbs.	 <b>78169</b> 48 lbs.
 <b>78170</b> 42 lbs.	 <b>78172</b> 50 lbs.	 <b>78173</b> 63 lbs.	 <b>78174</b> 63 lbs.

**The NORCO Difference:**

Welded frame means no assembly required

**78013A**



**12 TON CAPACITY HAND PUMP OPERATED**

**FEATURES**

- Manual pump power unit with "Parkerized" pump piston, ram and extension screw to inhibit rust from entering the hydraulic system.
- Pair of bed plates included.
- Shielded heavy duty ram return springs.
- Power unit is bearing mounted for horizontal movement on head channel.
- Zero distortion, heavy duty structural steel frame.
- Optional equipment below can be used on model 78022D press. Model 78000 arbor plates and model 78032 bearing puller below can be used on model 78013A press.



**INTENDED USE**

Straightening, bending & pressing. Removing & installing gears, bearings & bushings.

**78024**

**25 TON CAPACITY AIR/HYDRAULIC PUMP OPERATED**

**INTENDED USE**

Straightening, bending and pressing. Removing and installing gears, bearings and bushings.

**FEATURES**

- Air/hydraulic foot pump provides hands free operation.
- Note:** See page 36 for additional information on the model 910130A pump.
- Pair of bed plates included.
- Self-retracting ram can slide for horizontal movement on head channel.
- Zero distortion, heavy duty structural steel frame.
- Liquid filled gauge measures ram force and internal working pressure.
- Optional equipment, Model 78025 Accessory Kit can be used on this press. (see below)

**NOTE:**  
Model not shown has same basic construction as model pictured.



**78013A**  
(12 TON)  
**78022D (shown)**  
(20 TON)



MODEL NUMBER	CAPACITY	RAM TRAVEL	THROAT HEIGHT		THROAT WIDTH	BED HEIGHT ADJUSTMENTS	BETWEEN UPRIGHTS	BETWEEN BED RAILS	BASE		OVERALL HEIGHT	SHIPPING WEIGHT (Lbs.)
			MIN.	MAX.					WIDTH	DEPTH		
<b>78013A</b>	12 Ton	5.875"	5"	38.25"	25"	8 x 4.75"	5"	6"	34"	28"	70.625"	266
<b>78022D</b>	20 Ton	6.625"	7.125"	35.5"	30"	7 x 4.75"	6"	7"	40"	28"	70.625"	394
<b>78024</b>	25 Ton	8"	6.75"	40"	30.5"	8 x 4.75"	6"	7"	40"	28"	76.75"	430

**OPTIONAL EQUIPMENT:**

**78025**

**ACCESSORY KIT FOR 20 & 25 TON CAPACITY SHOP PRESSES**

Weight: 40 lbs.

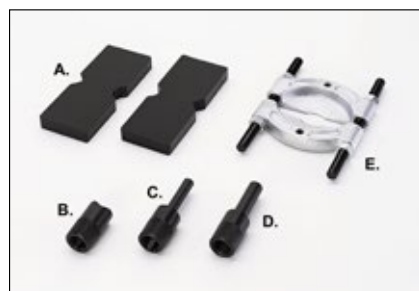

**INCLUDES:**

- A. MODEL 78033 - Arbor Plates
- B. MODEL 78028 - "V" Pushing Adapter
- C. MODEL 78029 - 3/4" Diameter Ram
- D. MODEL 78031 - 1" Diameter Ram
- E. MODEL 78032 - Bearing Puller



**78000**

**ARBOR PLATES**

A pair of 1" x 4" x 10" long steel plates with "V" cutout on one edge and circle cutout on the other. For 12, 20 and 25 ton capacity presses only. Weight: 20 lbs.



**78021**

**HYDRAULIC GAUGE WITH FITTINGS**

4" Diameter face designed to work with NORCO 12 & 20 ton presses. Weight: 2 lbs.



**78055A**

**50 TON CAPACITY HAND PUMP OPERATED**

**INTENDED USE**

Heavy duty use in truck garages and industrial workshops.



**78057A**

6.25" Stroke



**78077**

13.25" Stroke

**50 TON CAPACITY AIR/HYDRAULIC PUMP OPERATED**

**INTENDED USE and FEATURES**

Same as model 78055A but equipped with an air/hydraulic foot pump and model 910036A 10' hose. **Note:** See pages 36 & 37 for additional information on pumps.



**78058A**

6.25" Stroke



**78078**

13.25" Stroke

**50 TON CAPACITY ELECTRO/HYDRAULIC PUMP OPERATED**



**78110C**

**100 TON CAPACITY ELECTRO/HYDRAULIC PUMP OPERATED**

**INTENDED USE and FEATURES**

Same as model 78055A but the model 78058A is equipped with the model 910052A electro/hydraulic pump and the model 78110C is equipped with the model 910019B electro/hydraulic pump. **Note:** See page 37 for additional information on pumps.



**FEATURES**

- Safety overload system protects power unit.
- Hand operated winch raises and lowers press bed.
- Liquid filled gauge measures ram force in pounds and tons.
- Self-retracting ram is bearing mounted for lateral movement on head channel.

**The NORCO Difference:**

Welded frame means no assembly required

**78055A** (50 TON) **78058A (shown)** (50 TON)

**78057A** (50 TON) **78078** (50 TON)

**78077** (50 TON) **78110C** (100 TON)

**NOTE:**

Models not shown have same basic construction as model pictured.

**A. 78056A**



**50 TON CAPACITY PAIR OF ARBOR PLATES**

used with all 50 ton capacity presses. Weight: 108 lbs.



**78111A**



**100 TON CAPACITY PAIR OF ARBOR PLATES**

used with model 78110C shop press. Weight: 153 lbs.



**OPTIONAL EQUIPMENT:**

**78060**

**ACCESSORY KIT FOR 50 TON CAPACITY SHOP PRESSES**

Weight: 143.5 lbs.

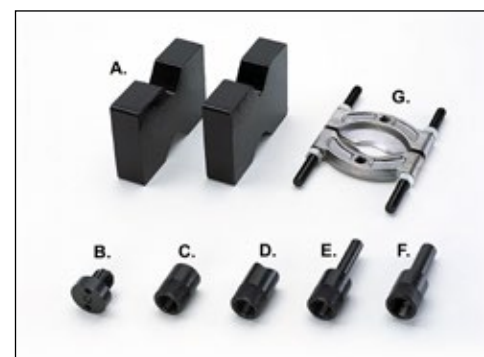

**INCLUDES:**

- A. MODEL 78056A - Arbor Plates
- B. MODEL 78059 - Threaded Adapter
- C. MODEL 78061 - Ram Cap
- D. MODEL 78062 - "V" Pushing Adapter
- E. MODEL 78063 - 1" Diameter Ram
- F. MODEL 78064 - 1-1/4" Diameter Ram
- G. MODEL 78066 - Bearing Puller



MODEL NUMBER	CAPACITY	RAM TRAVEL	THROAT HEIGHT		THROAT WIDTH	BED HEIGHT ADJUSTMENTS	BETWEEN UPRIGHTS	BETWEEN BED RAILS	BASE		OVERALL HEIGHT	SHIPPING WEIGHT
			MIN.	MAX.					WIDTH	DEPTH		
<b>78055A</b>	50 Ton	6.25"	7.5"	32.625"	34.5"	7 x 5"	5.625"	7.375"	50"	40"	72.75"	804 lbs.
<b>78057A</b>	50 Ton	6.25"	7.5"	32.625"	34.5"	7 x 5"	5.625"	7.375"	50"	40"	72.75"	801 lbs.
<b>78058A</b>	50 Ton	6.25"	7.5"	32.625"	34.5"	7 x 5"	5.625"	7.375"	50"	40"	72.75"	814 lbs.
<b>78077</b>	50 Ton	13.25"	7.5"	32.625"	34.5"	7 x 5"	5.625"	7.375"	50"	40"	72.75"	833 lbs.
<b>78078</b>	50 Ton	13.25"	7.5"	32.625"	34.5"	7 x 5"	5.625"	7.375"	50"	40"	72.75"	846 lbs.
<b>78110C</b>	100 Ton	10.25"	18.25"	45.75"	40.25"	8 x 4.5"	5.625"	9"	58"	40"	81"	1,777 lbs.



**The NORCO Difference:**

"Parkerized" moving parts offer corrosion protection

**BOTTLE JACKS**  
**2, 3, 5, 8, 12,**  
**20, 35, & 60**  
**TON CAPACITY**

**INTENDED USE**

For heavy duty truck, agriculture, construction, mining, mobile home, oil field, automotive, and marine applications where lifting, pushing, spreading, bending, pressing, or straightening are required.

**LONG HAND JACKS**  
**1-1/2 & 3 TON**  
**CAPACITY**

**INTENDED USE**

Various farm applications, but primarily used as original equipment for manufacturers of shop cranes, lift tables and any equipment requiring a long hydraulic stroke.

**FEATURES**

- Two piece zinc plated handle.
- Prevent rust with "Parkerized" pump piston, ram and extension screw.
- No leak "Uniweld" construction.
- 50% safety overload factor.
- State-of-the-art design reduces repair time.
- Longer wear life due to internally machined oil passages, smooth bearing surfaces and close tolerances.
- Lightweight forged base provides more steel only where strength is required.
- The heavy-duty extension screw and release valve were designed to eliminate parts and reduce the chances of breakage and excessive wear.
- Safety oil by-pass system prevents the ram from being overextended and causing damage to the cylinder.

**ADDITIONAL FEATURES**  
**12 and 20 TON CAPACITY**

- "G" models are designed with a removable plug so a gauge can be adapted to the jack. (See page 28 for model 78021 gauge.)

**ADDITIONAL FEATURES**  
**35 and 60 TON CAPACITY**

- All other features excluding extension screw.
- A safety overload system which prevents the jack from being used beyond its rated capacity.

**LONG HAND JACK FEATURES**

- Same as bottle jack features but designed with larger hydraulic units and larger ram diameters to withstand side loads.
- Larger diameter pump pistons for faster rising action.
- "Parkerized" rams and flash chromed pump pistons inhibit rust.



Note: Models not shown have the same basic construction as models pictured.



MODEL NUMBER	CAPACITY	LIFT HEIGHT		STROKE	SCREW EXTENSION	BASE SIZE	CARRY HANDLE	SHIPPING WEIGHT
		Low	High					
<b>76502A</b>	<b>2 Ton</b>	7.13"	14.5"	4.94"	2.44"	3.5" x 4.13"	No	6 lbs.
<b>76503A</b>	<b>3 Ton</b>	7.5"	15.56"	5.25"	2.81"	4" x 4.56"	No	8 lbs.
<b>76505A</b>	<b>5 Ton</b>	9.06"	18.88"	6.69"	3.13"	4.88" x 4.88"	No	11.5 lbs.
<b>76508A</b>	<b>8 Ton</b>	9.06"	18.75"	6.5"	3.19"	5.38" x 5.13"	Yes	14 lbs.
<b>76412A</b>	<b>12 Ton</b>	9.45"	18.9"	5.91"	3.54"	5.51" x 5.51"	Yes	18 lbs.
<b>76412AG</b>								
<b>76512A</b>	<b>12 Ton</b>	6.69"	13.19"	3.74"	2.76"	5.51" x 5.51"	Yes	15 lbs.
<b>76520A</b>	<b>20 Ton</b>	10.83"	20.2"	6.61"	2.76"	6.57" x 6.06"	Yes	31 lbs.
<b>76520AG</b>								
<b>76820A</b>	<b>20 Ton</b>	8.27"	14.96"	3.94"	2.76"	6.57" x 6.06"	Yes	25 lbs.
<b>76535</b>	<b>35 Ton</b>	11"	17.38"	6.31"	--	5.63" x 7.56"	Yes	42 lbs.
<b>76560</b>	<b>60 Ton</b>	12"	18.75"	6.69"	--	7.44" x 9.31"	Yes	82 lbs.
<b>LONG HAND JACKS</b>								
<b>76402A</b>	<b>1.5 Ton</b>	22.6"	41.9"	19.3"	--	4.05" x 4.57"	No	17.5 lbs.
<b>76403A</b>	<b>3 Ton</b>	24"	43.5"	19.5"	--	4.88" x 4.40"	No	24 lbs.

**The NORCO Difference:**

More quality features in a unique design

**FEATURES**

- Fast efficient air pump reduces lifting time and has a built-in relief mechanism which prevents the jack from being used beyond its maximum capacity.
- Convenient push button air valve connected to an in-line filter prevents contaminants from entering the air/hydraulic system.
- Unique design allows for manual operation when air is not available.
- Two piece zinc plated handle.
- Parkerized coating on pump piston, extension screw and extension adapters and chrome coated ram offer protection against rust.
- Longer wear life due to internally machined oil passages, smooth bearing surfaces and close tolerances.
- Safety oil by-pass system prevents the ram from being overextended and causing damage to the cylinder.
- Carrying handle.



\*Note: Models not shown have the same basic construction as models pictured.

76312A (shown)  
\*76320A  
\*76720A



MODEL NUMBER	CAPACITY	LIFT HEIGHT		STROKE	SCREW EXTENSION	BASE SIZE	P.S.I. RANGE	SHIPPING WEIGHT
		Low	High					
<b>76312A</b>	<b>12 Ton</b>	9.63"	19.75"	6"	4"	6.63" x 8"	100-130	24 lbs.
<b>76320A</b>	<b>20 Ton</b>	10.88"	20.5"	6.75"	2.75"	7.5" x 9.25"	100-130	41 lbs.
<b>76720A</b>	<b>20 Ton</b>	8.25"	14.5"	4"	2.25"	7.5" x 9.25"	100-130	34 lbs.

**76312A**

**12 TON CAPACITY**  
**STANDARD HEIGHT**

**76320A**

**20 TON CAPACITY**  
**STANDARD HEIGHT**

**76720A**

**20 TON CAPACITY**  
**LOW HEIGHT**

**INTENDED USE**

For use in heavy duty trucks, farm equipment, building construction, construction and mining equipment, mobile home set-up and oil field applications.

**The NORCO Difference:**

Portable lifting for professional or DIY

**NORCO PORTABLE MID-RISE LIFT**

**86002A**

**55" MID-RISE LIFT**  
**6,000 LBS. CAPACITY**

**INTENDED USE**

Lifts cars, vans and light-duty trucks for wheel and brake related repairs, tire and wheel changing, collision repair work and new car preparation.

**86010A**

**EXTENSION ADAPTERS**

For higher frame clearance vehicles. Includes four 4-1/2" extension adapters for use with swivel rubber lifting pads included with the 86002A. Weight: 18 lbs.

**FEATURES**

- Portable trolley supports the pump and maneuvers the lift from one service bay to another.
- Twin hydraulic cylinders and scissors lift design provide maximum support and stability.
- Hydraulic velocity fuses allow slow release of lift in the event of hose or hydraulic component damage.
- 4-1/2" low height for easy drive on and off.
- Fast and efficient operating pump powered by a 1 hp, 115 volt motor (1 year warranty on pump and motor).
- Sliding radius arms easily adjust to vehicle frame lift positions.
- Automatic mechanical safety lock will lock in a 24-1/2", 31", 36-3/4", 42-1/8", 46-1/2", 50-3/4", or 55" lift height.
- 12' hydraulic hose & 12-1/2' release cable.



MODEL NUMBER	CAPACITY	OVERALL DIMENSIONS		LIFT HEIGHT		SHIPPING WEIGHT
		Length	Width	Low	High	
<b>86002A</b>	<b>6,000 lbs.</b>	96.5"	39.75"	5.5"	55"	965 lbs.

**904004B****4 TON CAPACITY KIT  
(FORGED ADAPTERS)****904005A****4 TON CAPACITY KIT  
(CAST ADAPTERS)****INTENDED USE**

For collision repair, industrial and construction applications where convenience of hydraulic power can be utilized for spreading, clamping, pushing and lifting operations.

**NOTE: Cast & forged adapter components vary in size and are not interchangeable.**

**FEATURES**

- "Quick-Lock" design for fast and easy assembly and disassembly.
- Long handle provides ease of pumping.
- Thick walled extension tubes for added strength and longer life.
- Roto-molded plastic case for organized component storage and ease of carrying.
- Flexible hydraulic hose with spring guards at both ends.
- Forged steel adapters for added strength and durability (904004B/910005B).
- All casting parts are made of nodular cast iron (904005A/910006A).

**Kit Weight:**

904004B: 41 lbs.  
904005A: 42 lbs.

**The NORCO Difference:**

Multiple price points with cast or forged steel adapters

**4 TON kits include:**

- PLASTIC CASE
- 10,000 P.S.I. PUMP
- 6' HOSE
- 4" STROKE RAM
- WEDGE RAM (1/2 TON CAP.)
- 4", 8", 12" AND 16" EXTENSION TUBES
- TUBE CONNECTOR
- SERRATED SADDLE
- RUBBER HEAD
- WEDGE HEAD
- RAM TOE
- PLUNGER TOE
- RUBBER FACED FLAT BASE
- 90 DEGREE "V" BASE

**904004B (shown)**

**\*904005A**

(4 TON)

**910005B****10 TON CAPACITY KIT  
(FORGED ADAPTERS)****910006A****10 TON CAPACITY KIT  
(CAST ADAPTERS)****INTENDED USE**

Same as 4 ton kits but for heavier jobs such as automotive frame straightening.

**NOTE: Cast & forged adapter components vary in size and are not interchangeable.**

**FEATURES**

- All the same features found in the 4 ton kits.

**Kit Weight:**

910005B: 83 lbs.  
910006A: 77 lbs.

**10 TON kits include:**

- WHEELED PLASTIC CASE
- 10,000 P.S.I. PUMP
- 6' HOSE
- 6" STROKE RAM
- WEDGE RAM (1/2 TON CAP.)
- 5", 10", 14" AND 19" EXTENSION TUBES
- TUBE CONNECTOR
- SERRATED SADDLE
- RUBBER HEAD
- WEDGE HEAD
- 90 DEGREE "V" BASE
- FLAT BASE
- RAM TOE
- PLUNGER TOE

**910005B (shown)**

**\*910006A**

(10 TON)

**920020****20 TON CAPACITY KIT  
(FORGED ADAPTERS)****INTENDED USE**

A deluxe kit for repairing heavy road machinery, trucks, farm equipment and also used for some heavy construction applications.

**MODEL 920020 KIT includes:**

- STEEL CASE (1 OF 2)
- 2-SPEED PUMP
- 5' HOSE
- RAM, 5" STROKE
- 3-1/2" DIA. SADDLE (2)
- THREADED COUPLER (3)
- TOE LIFT
- WEDGE HEAD
- VEE HEAD
- STEEL CASE (2 OF 2)
- 3" EXTENSION TUBE (2)
- 5" EXTENSION TUBE
- 10" EXTENSION TUBE
- 20" EXTENSION TUBE
- 27-1/2" EXTENSION TUBE
- 6-1/2" DIA. BASE (2)

**FEATURES**

- Two steel cases with carrying handles share the weight for easier handling of kit.
- Two-speed pump quickly raises ram to load and secondary pump provides powerstroke.

**Kit Weight:** 152 lbs.**FEATURES**

- Heavy duty rubber hoses rated at 10,000 P.S.I. meet IJ-100 specifications. Hoses are rubber coated with 2 layers of braided steel and offer flexibility with little memory. Strain relief type fittings are crimped on for improved life and durability.
- Quick connect 3/8" high flow couplers allow fast set-up of hydraulic systems. All couplers include two-in-one dust cap for use on male and female coupler halves.



MODEL NUMBER	DESCRIPTION	CAPACITY	HOSE OR COUPLER I.D.	CONNECTION	WEIGHT
<b>910035A</b>	6.5' Long Hose	<b>10,000 P.S.I.</b>	.375"	.375 NPT Male Both Ends	4.5 lbs.
<b>910036A</b>	10' Long Hose	<b>10,000 P.S.I.</b>	.375"	.375 NPT Male Both Ends	7 lbs.
<b>910037A</b>	Coupler, Hose Half	<b>10,000 P.S.I.</b>	.375"	.375 NPT Male End	1 lbs.
<b>910038A</b>	Coupler, Cylinder Half	<b>10,000 P.S.I.</b>	.375"	.375 NPT Female End	1 lbs.

**HOSES AND COUPLERS****INTENDED USE**

These heavy duty hoses and couplers are used to join pumps and cylinders together (see pages 34-37).

**910043A & 925142A**

Heavy duty bases provide firmer and more stable footing for cylinders.

**910044A & 925143A**

Threaded male connectors adapt bases to the cylinders.

**910046A & 925141A**

Grooved saddles protect the cylinder ends and provide a better gripping surface.

**BASES, SADDLES & ATTACHMENTS****910048 & 925148**

Threaded adapters screw into the tops of the cylinders and provide a threaded connection for other attachments.

**910039 & 925045**

Base attachments are bolted to the bottom of the cylinders and are internally threaded to receive other attachments.

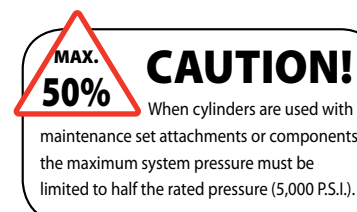

MODEL NUMBER	DESCRIPTION	CAPACITY	FOR USE ON CYLINDERS	CONNECTION (NPT)	WEIGHT
<b>910043A</b>	3.5" x 6.5" Base	<b>5 Ton</b>	10 Ton Cap.	1.25 x 11.5 Female	3.5 lbs.
<b>925142A</b>	6.5" Dia. Base	<b>12-1/2 Ton</b>	25 Ton Cap.	2 x 11.5 Female	9.5 lbs.
<b>910044A</b>	Male Connector	<b>5 Ton</b>	10 Ton Cap.	1.25 x 11.5 Male	0.5 lbs.
<b>925143A</b>	Male Connector	<b>12-1/2 Ton</b>	25 Ton Cap.	2 x 11.5 Male	4.5 lbs.
<b>910046A</b>	1.375" Dia. Grooved Saddle	<b>10 Ton</b>	10 & 15 Ton Cap.	—	0.5 lbs.
<b>925141A</b>	2" Dia. Grooved Saddle	<b>25 Ton</b>	25 Ton Cap.	—	0.5 lbs.
<b>910048</b>	Threaded Adapter	<b>5 Ton</b>	10 & 15 Ton Cap.	1.25 x 11.5 Male	1 lbs.
<b>925148</b>	Threaded Adapter	<b>12-1/2 Ton</b>	25 Ton Cap.	2 x 11.5 Male	2.5 lbs.
<b>910039</b>	Base Attachment	<b>5 Ton</b>	10 Ton Cap.	1.25 x 11.5 Female	2 lbs.
<b>925045</b>	Base Attachment	<b>12-1/2 Ton</b>	25 Ton Cap.	2 x 11.5 Female	5.5 lbs.

**910100B****FLOW CONTROL VALVE**

Manually adjusted fine metering valve rated at 10,000 P.S.I. that fits between the pump and cylinder. The valve controls the flow of oil returning to the reservoir when pressure is released. Valve includes 3/8" NPTF male and female connections. Weight: 1 lb.

**CYLINDERS**

**INTENDED USE**

For many applications including shop, agricultural, automotive / truck service needs and construction maintenance applications where lifting, pushing, pulling, bending or holding may be required.



**NOTE:**  
Models not shown have same basic construction as model pictured.



**SINGLE-ACTING CYLINDERS**

MODEL NUMBER	CAPACITY	STROKE (Inches)	OIL CAP (Cu. In.)	CYLINDER BORE DIA. (Inches)	CYLINDER EFFECTIVE AREA(Sq.In.)	RETURN SPRING	HEIGHT		OUTSIDE DIA.		THREAD SIZE		SHIPPING WEIGHT
							Min.	Max.	Piston	Cylinder	Piston (NPT)	CYL COLLAR (Inches x Thrd.)	
910026A	10 Ton	6.13	13.67	1.69	2.23	YES	12.5"	18.63"	1.5"	2.25"	1.25 x 11.5	2.25 x 14	10 lbs.
910027A	10 Ton	2.13	4.75	1.69	2.23	YES	4.5"	6.63"	1.5"	2.25"	---	2.25 x 14	6 lbs.
910029A	10 Ton	10.13	22.59	1.69	2.23	YES	16.5"	26.63"	1.5"	2.25"	1.25 x 11.5	2.25 x 14	14 lbs.
910030	10 Ton	12	26.76	1.69	2.23	YES	15.75"	27.75"	1.5"	2.25"	---	2.25 x 14	16.5 lbs.
910047	10 Ton	14	31.22	1.69	2.23	YES	17.75"	31.75"	1.5"	2.25"	---	2.25 x 14	18 lbs.
915006	15 Ton	6	18.84	2.00	3.14	YES	10.69"	16.69"	1.63"	2.75"	---	2.75 x 16	15 lbs.
925026B	20 Ton	1.75	7.77	2.38	4.44	YES	3.88"	5.63"	2.00"	3.63"	---	---	11 lbs.
925023	25 Ton	4	20.60	2.56	5.15	YES	8.5"	12.5"	2.25"	3.38"	---	3.31 x 12	18 lbs.
925024	25 Ton	10.25	52.79	2.56	5.15	YES	14.75"	25"	2.25"	3.38"	---	3.31 x 12	31 lbs.
925025A	25 Ton	6.25	32.19	2.56	5.15	YES	14.88"	21.13"	2.25"	3.38"	2 x 11.5	3.31 x 12	22 lbs.
925027A	25 Ton	14.25	73.39	2.56	5.15	YES	22.88"	37.13"	2.25"	3.38"	2 x 11.5	3.31 x 12	39 lbs.
930003	30 Ton	2.44	15.85	2.88	6.50	YES	4.63"	7.06"	2.62"	4.00"	---	---	15 lbs.
950005	50 Ton	2.38	22.91	3.50	9.63	YES	4.81"	7.19"	2.75"	5.00"	---	---	24 lbs.
955019A	50 Ton	6.25	69.06	3.75	11.05	YES	11.13"	17.38"	3.13"	5.00"	---	5 x 12	51 lbs.
999000	100 Ton	10.25	211.66	5.13	20.65	YES	17.69"	27.94"	4.13"	7.00"	---	6.89 x 12	160 lbs.

**DOUBLE-ACTING CYLINDERS**

MODEL NUMBER	CAPACITY (Tons)		STROKE (Inches)	OIL CAP (Cu. In.)		CYLINDER BORE DIA. (Inches)	CYLINDER EFFECTIVE AREA(Sq.In.)	HEIGHT		OUTSIDE DIA.		SADDLE DIAMETER	COLLAR THREAD SIZE	SHIPPING WEIGHT	
	Push	Pull		Push	Pull			Min.	Max.	Piston	Cylinder				
910010	10	4	10	22.33	8.00	1.69	2.23	.80	16.125"	26.13"	1.38"	2.88"	1.38"	2.25 x 14	28 lbs.
930008	30	5	8.25	53.67	25.00	2.88	6.51	3.00	15.25"	23.5"	2.13"	4.00"	2"	3.31 x 12	40 lbs.
955106	50	10	6.125	67.77	21.00	3.75	11.06	3.40	13.06"	19.19"	3.13"	5.00"	2.81"	5 x 12	67 lbs.
999106	100	48	6.625	136.93	63.00	5.13	20.65	9.60	14.06"	20.69"	3.75"	7.00"	3"	6.88 x 12	135 lbs.

**WEDGE RAM**

MODEL NUMBER	CAPACITY	ARM HEIGHT		OVERALL DIMENSIONS			CYLINDER AREA (Cu.In.)	OIL CAP (Cu.In.)	SHIPPING WEIGHT
		CLOSED	OPEN	HEIGHT	WIDTH	LENGTH			
910028A	1 Ton	.38"	3.69"	2.01"	2.01"	8.78"	1.00	.61	5 lbs.

**FEATURES**

- Lightweight aluminum body.
- Extremely durable.
- Ships completely assembled with coupler, shutoff, and base.
- The perfect cylinder for heavy-duty road service.
- These portable cylinders lift 50 tons with 10,000 P.S.I. hydraulic pumps.



955055

**50 TON ALUMINUM RAM w/ BASE & SHUTOFF VALVE**

**INTENDED USE**  
Made for lifting heavy off-road and construction equipment.



MODEL NUMBER	CAPACITY	STROKE (Inches)	OIL CAP (Cu. In.)	CYLINDER BORE DIA. (Inches)	CYLINDER EFFECTIVE AREA(Sq.In.)	RETURN SPRING	HEIGHT		OUTSIDE DIA.		SHIPPING WEIGHT
							Min.	Max.	Piston	Cylinder	
955055	50 Ton	6.25	69	3.75	11.05	YES	11.75"	18"	3.13"	6"	39 lbs.

**COMPATIBILITY CHART**

HYDRAULIC CYLINDERS (Page 34)

PUMPS (Pages 36-37)	910010	910026A	910027A	910028A	910029A	910030	910047	915006	925023	925024	925025A	925026B	925027A	930003	930008	950005	955019A	955055	955070	955106	999000	999106	
910017B		●	●	●	●	●	●	●	●	●	●	●	●	●	●	●	●	●	●	●	●	●	●
910018B		●	●	●	●	●	●	●	●	●	●	●	●	●	●	●	●	●	●	●	●	●	●
910019B		●	●	●	●	●	●	●	●	●	●	●	●	●	●	●	●	●	●	●	●	●	●
910020		●	●	●	●	●	●	●	●	●	●	●	●	●	●	●	●	●	●	●	●	●	●
910052A		●	●	●	●	●	●	●	●	●	●	●	●	●	●	●	●	●	●	●	●	●	●
910130A		●	●	●	●	●	●	●	●	●	●	●	●	●	●	●	●	●	●	●	●	●	●
910140		●	●	●	●	●	●	●	●	●	●	●	●	●	●	●	●	●	●	●	●	●	●
925009A		●	●	●	●	●	●	●	●	●	●	●	●	●	●	●	●	●	●	●	●	●	●
925010A		●	●	●	●	●	●	●	●	●	●	●	●	●	●	●	●	●	●	●	●	●	●
925011		●	●	●	●	●	●	●	●	●	●	●	●	●	●	●	●	●	●	●	●	●	●
925012A		●	●	●	●	●	●	●	●	●	●	●	●	●	●	●	●	●	●	●	●	●	●
925013B		●	●	●	●	●	●	●	●	●	●	●	●	●	●	●	●	●	●	●	●	●	●
925014	●																						

**Note:** A dot inside a square indicates there is sufficient oil in the pump to operate the cylinder to maximum extension. Although some pumps and cylinders are compatible, the useable oil capacity in both are so close that longer hoses (requiring more oil) that connect both components may prevent the pump from operating the cylinder to maximum extension.

**The NORCO Difference:**  
Safe, reliable, dependable performance

**910017B 910018B**  
**910130A 910140**

**10,000 P.S.I. CAPACITY**

**INTENDED USE**

For automotive / truck, industrial & construction jobs. The added convenience of an air motor reduces pumping time and effort to activate cylinders.

**FEATURES**

- Designed to utilize exhaust air to help power the pump, requiring only 80 P.S.I. air pressure to develop 10,000 P.S.I. hydraulic pressure.
- Air exhaust muffler for quieter operation.
- Air and oil inlet filters for reduced risk of damage from contamination.
- Designed with durable light weight, corrosion resistant plastics.
- Foot pedal provides hands free pumping and release of load.
- Designed to be used with a single-acting cylinder.
- Internal pressure relief valve for overload protection.
- Model 910018B has two-gallon capacity steel reservoir body.



910017B



910018B



910130A



910140

**FEATURES**

Same as the models 910017B and 910018B but with added features:

- The model 910130A pump is equipped with a more durable aluminum reservoir.
- Both models 910130A and 910140 come with two different size poppit valves that can be quickly and easily installed. Poppit valves reduce the return flow of oil back to the pump's reservoir providing a safer controlled lowering of load.
- The model 910140 pump is equipped with a thick wall aluminum extruded reservoir.

**910020**

**3,250 P.S.I. CAPACITY**

**INTENDED USE**

Same as the model 910017B, but with a steel reservoir body, a manually activated push button for pumping and a lever for release of load. The pump operates in all positions for increased versatility in use and mounting.



MODEL NUMBER	HYDRAULIC PRESSURE RATING (P.S.I.)	USABLE OIL CAP. (Cu. In.)	OUTPUT FLOW RATE (Cu. In. Per Min.)		AIR PRESSURE RANGE (P.S.I.)	AIR CONSUMPTION (scfm)	VALVE FUNCTION	SOUND LEVEL (dBA)	THREAD CONNECTIONS		DIMENSIONS (Inches)			WEIGHT (Lbs.)
			No Load	Load					AIR (NPT)	HYDRAULIC (NPT)	Length	Width	Height	
<b>910017B</b>	10,000	127	60	10	25-125	12	Advance / Hold Retract	76	.25"-18	.375"-18	13.63"	6.19"	8.19"	14
<b>910018B</b>	10,000	462	60	10	25-125	12	Advance / Hold Retract	76	.25"-18	.375"-18	13.63"	12"	11.38"	38
<b>910020</b>	3,250	36	40	8	60-120	9	Advance / Hold Retract	85	.25"-18	.125"-27	15.5"	4.5"	5"	9
<b>910130A</b>	10,000	122	80.5	12.8	40-170	24	Advance / Hold Retract	85	.25"-18	.375"-18	12.5"	5.75"	8"	22
<b>910140</b>	10,000	462	80.5	12.8	40-170	24	Advance / Hold Retract	85	.25"-18	.375"-18	14"	8.5"	10.75"	44

**The NORCO Difference:**  
Portable and durable high performance

**STEEL HAND PUMP FEATURES**

**925009A, 925010A, & 925013B**

- 3/8 NPT hose connection on all pumps.
- Internal pressure relief valves for overload protection.
- External load release valve for single-acting cylinder operation.
- Two-speed pump operation on model 925013B for reduced operator fatigue.

**LIGHTWEIGHT HAND PUMP FEATURES**

**925011, 925012A, & 925014**

- Same as for the steel hand pumps but with the following additions:
- Durable glass-filled nylon reservoir and nylon encapsulated aluminum pump base for maximum corrosion resistance and lightweight handling.
- Two-speed pump operation on models 925011 and 925014 reduces handle strokes by as much as 78% over single speed pumps.
- Integral 4-way valve on the model 925014 for operation of double-acting cylinders.
- Handle lock for easy carrying.
- Non-conductive fiberglass handle for operator safety.

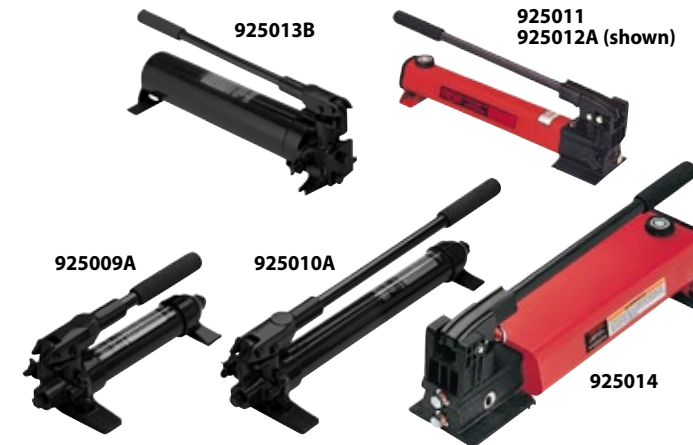

**NOTE:**  
Models not shown have same basic construction as model pictured.



**HAND PUMPS**

**INTENDED USE**

For many applications including shop, agricultural, automotive/truck service needs and construction maintenance applications where high pressure pumps are required to activate cylinders rated as high as 55 ton capacity.

PUMP TYPE	Single Speed	Two Speed	Steel	Light Weight	MODEL NUMBER	PRESSURE RATING (P.S.I.)		USABLE OIL CAP. (Cu. In.)	OIL DISPLACEMENT PER STROKE (Cu. In.)		MAXIMUM HANDLE EFFORT (Lbs.)	PISTON STROKE (In.)	DIMENSIONS (Inches)			PUMP HANDLE ARC	WEIGHT (Lbs.)
						1st. Stage	2nd. Stage		1st. Stage	2nd. Stage			Length	Width	Height		
●			●		<b>925009A</b>	2,850	—	18	.16	—	57	.81	13.38	5.25	5.25	40°	11
●			●		<b>925010A</b>	10,000	—	40	.16	—	111	.81	23	5.25	5.25	40°	13
	●			●	<b>925011</b>	200	10,000	55	.687	.151	93	1.00	21.63	4.75	7	50°	9
●				●	<b>925012A</b>	10,000	—	55	.151	—	85	1.00	21.63	4.75	7	50°	9
	●		●		<b>925013B</b>	350	10,000	134	.99	.15	104	1.00	22.5	5.75	7	50°	24
	●			●	<b>925014</b>	400	10,000	155	2.40	.151	95	1.00	21.75	4.75	9	50°	22

**The NORCO Difference:**  
Best in class

**910019B**

**FEATURES**

- Two-speed design reduces cycle times for improved productivity.
- Single-phase 115 VAC, 1 hp induction motor will start at full load and stand up to continuous duty applications. Requires a steady power supply.
- 10 foot pendant controls the motor operation.
- Manual advance/retract valve control for single-acting cylinders.
- LCD display provides a number of diagnostic and readout capabilities.



910052A

**910052A**

**FEATURES**

- Lightweight and compact design.
- High strength molded shroud with integral easy-carry handle protects motor from contamination.
- 115 VAC, 1/2 hp motor operates on voltages as low as 60 volts.
- 10 foot pendant for operator safety.
- Two-speed motor design with 3-way 2-position valve for use with single-acting cylinders.



910019B

**910019B and 910052A**

**10,000 P.S.I. CAPACITY**

**INTENDED USE**

Same as for the air/hydraulic pumps but will handle single-acting cylinders up to 100 ton. The added convenience of an electro-hydraulic pump reduces pumping time and effort.

**NOTE: All electrical motors are warranted against defects in material and workmanship for one year from the date of end user's purchase.**



MODEL NUMBER	HYDRAULIC PRESSURE RATING (P.S.I.)		USABLE OIL CAP. (Cu. In.)	OUTPUT FLOW RATE (Cu. In. Per Min.)		CURRENT DRAW (Amps.)	MOTOR VOLTAGE (VAC)	SOUND LEVEL (dBA)	THREAD CONNECTION (NPT)	VALVE TYPE	DIMENSIONS (Inches)			WEIGHT (Lbs.)
	1st. Stage	2nd. Stage		1st. Stage	2nd. Stage						Length	Width	Height	
<b>910019B</b>	450	10,000	462	400	40	20	115	75	.375"-18	Advance / Retract	19	9.75	23	73
<b>910052A</b>	200	10,000	238	200	20	9.5	115	85	.375"-18	Advance / Hold Retract	14.5	12.25	14.75	31

# A NATIONAL NETWORK OF AUTHORIZED SERVICE CENTERS PROVIDE PROFESSIONAL NORCO SERVICE AND REPAIR

## LIMITED LIFETIME WARRANTY *Effective: February 25, 2010*

NORCO Professional Lifting Equipment's products and parts<sup>1</sup> are warranted against defects in materials and workmanship for the life of the product or the part.

This warranty is expressly limited to persons who purchase NORCO products or parts for the purpose of resale or use in the ordinary course of the buyer's business.

This warranty does not cover any product or part that has been abused, misused, worn out, neglected, ground or otherwise altered, used for a purpose other than for which it was intended, or used in a manner inconsistent with any instructions regarding its use. In addition, this warranty does not cover any chains, batteries or electric motors, which are sold with NORCO products. All electric motors are separately warranted by their manufacturer under the conditions stated in the separate warranty.

THIS WARRANTY IS EXCLUSIVE AND NORCO MAKES NO OTHER WARRANTY OF ANY KIND WHATSOEVER, EXPRESS OR IMPLIED, WITH RESPECT TO THE SPECIFIED PRODUCTS OR PARTS MANUFACTURED AND/OR SOLD BY IT, INCLUDING, BUT NOT LIMITED TO, IMPLIED WARRANTIES OF MERCHANTABILITY OR FITNESS FOR A PARTICULAR PURPOSE OR ANY OTHER MATTER. No agent, employee or representative of NORCO, or any other person, has authority to bind NORCO to any affirmation, representation or warranty concerning NORCO products or parts except as set forth herein.

If any NORCO product or part is determined by NORCO, in its sole judgment, to be defective, NORCO will, at its option, either repair or replace such defective product or part. THIS REMEDY SHALL BE THE EXCLUSIVE REMEDY AVAILABLE FOR ANY DEFECTIVE NORCO PRODUCT OR PART AND FOR ALL DAMAGES RESULTING FROM ANY CAUSE WHATSOEVER, INCLUDING, WITHOUT LIMITATION, NORCO'S NEGLIGENCE. IN NO EVENT SHALL NORCO BE LIABLE TO ANY BUYER OR OTHER PERSON FOR CONSEQUENTIAL OR INCIDENTAL DAMAGES OF ANY KIND OR NATURE WHATSOEVER, WHETHER FOR DEFECTIVE OR NONCONFORMING GOODS, OR UNDER ANY THEORY OF LIABILITY, INCLUDING, BUT NOT LIMITED TO, BREACH OF CONTRACT (EXPRESS OR IMPLIED), NEGLIGENCE, STRICT LIABILITY OR OTHERWISE. The purpose of this exclusive remedy shall be to provide the buyer with repair or replacement of NORCO products or parts determined by NORCO to be defective in material or workmanship. This exclusive remedy shall not be deemed to have failed of its essential purpose so long as NORCO is willing and able to repair or replace said defective product or part in the prescribed manner.

<sup>1</sup> Excludes equipment and part numbers as noted in the NORCO Professional Lifting Equipment catalog or other literature, which have a separate Limited One-Year Warranty.

NORCO's four distribution centers ensure quick delivery across North America.

