



Precision's durable all stainless steel cabinets have been designed to provide commercial caterers with reliable, energy and cost efficient refrigerated storage solutions. Proudly made in the UK, these slimline cabinets are capable of meeting the highest demands of commercial kitchens all around the world - especially when space is at a premium.



Non-Gastronorm Shelving System With Anti-Tilt Slides

Key Features:

Stainless Steel Interior & Exterior

Designed To Operate In 43°C Ambient

Built-In Air Rear Duct For Even Temperature Distribution

R290 Hydrocarbon Refrigerant

Zero ODP Injected Polyurethane Insulation - 60mm

-2 / +10°C Refrigerator Temperature Range

Electronic Controller With Easy Read LCD Screen

Hot Gas Defrost

Door Locks Fitted As Standard

Rifle Bore Coated Evaporators

Ergonomic Flush Door Handle

Non Gastronorm Shelving System - (GN1/1 Pans Can Fit On Shelves) - Anti Tilt Slides

Hi / Lo Audio Visual Temperature Alarms

Condensing Unit Safety System To Protect Compressor From Blocked Condensers

Self Closing Doors

Heavy Duty Brake & Swivel Castors

Wast Heat Recovery Condensate Vaporiser System

Options:

Extra Std Nylon Coated Shelves / Slides

Extra Shelf / Pan Slides

Fish Shelving - 7 x GN1/1 - 100mm Deep - Stainless Steel Pans & Slides per section with Slime Trays

Stainless Steel Back

Left Hang Hung Door

Adjustable Legs

Remote - Excludes Condensing Unit But Includes R404a Expansion and Solenoid Valve (Fitted)

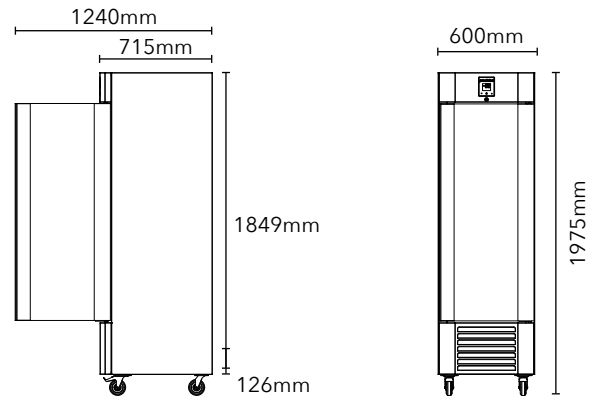

Model	MPU401	LPU401
Type	Refrigerator	Freezer
Material	ST/ST Int/Ext	ST/ST Int/Ext
Shelf Size	418 x 530mm	418 x 530mm
Number of Shelves	3	3
Max Number of Shelves (100mm Spacing)	9	9
Temperature Range	-2 / +15°C	-18 / -22°C
Exterior WxDxH (mm)	600x715x1975	600x715x1975
Net Usable Volume (litres)	264	264
Weight (KG)	110	120
Refrigerant / GWP	R290 /3	R290 /3
Refrigeration Watts (+45°C Condensing)	373	449
Evaporating Temp	-10°C	-30°C
Heat Rejection Watts	287	513
Noise Output (dBa)	67	69
Power	230 / 50 / 1	230 / 50 / 1
Running Current (Amps/Watts)	1.8 / 287	3.6 / 513
Energy Consumption / 24hrs - kWh*	1.28	6.14
Energy Consumption / Year (AEC) - kWh*	467	2241
Energy Efficiency Class*	C	E

*Tested to EN16825 Climate Test Class 4 - M1 Classification Test for Refrigerators / L1 Classification Test for Freezers

We are constantly innovating and improving our products. Please always check our website for the most up-to-date version of this spec sheet