



Product catalogue

Nilar EC

Energy storage with Nilar hydride[®]
battery technology

The ultimate sustainable energy storage solution. One that is efficient, safer and has a much smaller environmental footprint than other solutions in its class.

Who we are

Nilar brings you the next generation in modular power technology with the bi-polar Nilar Hydride[®] energy storage. The unique design of the battery delivers high power and assures reliability from a lighter, smaller and greener unit. From its two R&D departments in the USA and Sweden the company has revolutionized the way industrial batteries are constructed, developing a unique energy storage system that can be easily scaled to fit different applications. With a fully automated production line, the batteries are produced from battery cell to complete system at the company's state-of-the-art factory in Sweden.

Contents

Who we are	2	Electrochemistry	16
The Nilar EC battery and energy storage solutions	3	Operating features	18
Nilar Applications	4	Discharging.....	18
Home/Business storage	5	Charging	20
Commercial and Industrial energy storage solutions	5	Self discharge.....	20
EV-charge support.....	5	Cycle life	21
Nilar bi-polar modular design	6	Safety	22
The Nilar EC - Energy Compact battery pack ...	8	Transport	24
Nilar battery pack features	9	Sustainability	25
Nilar EC design	10	Nilar system components	26
Pack design	11	Battery system components	26
Nilar System Solutions	12	Integrated monitoring unit	27
Function description	12	Signals IMU	27
Nilar Battery Management System	13	BMS.....	27
Nilar EC System configurations	14	Programmable logical controller (PLC).....	27
		Circuit breaker	28
		Fuse.....	28
		Current sensor.....	28
		Insulation monitoring	28
		Cut-off contactor	28
		Fans.....	28
		Products	30

The Nilar EC battery and energy storage solutions

The EC in Nilar EC stands for Energy Compact. That's because the battery has an energy optimized cell design and more than 50% higher volumetric energy density than its predecessor. This new design has resulted in a 30% smaller unit, which gives it a remarkable gain in power to size ratio. The new battery has been developed to handle energy storage demands of key applications and to meet the growing need of reliable peak shaving and time shifting solutions. With our bi-polar Nilar Hydride® battery technology we can offer our customers a safer, more reliable and greener unit that can operate on a wide temperature range, with high power and long calendar lifetime.

Solutions and applications

Enormous infrastructure investments are required to upgrade the grid to cope with the long-term demands of the fast emerging electric vehicle market and the rise in distributed energy use from intermittent sources, such as wind and solar power.

In order to develop a fully functional smart grid, smart energy storage solutions are the only way forward for many governments and energy providers. But this should not be considered a short-term solution. With the right system, energy storage can act as an effective buffer for many years to come and be equally effective if and when grid upgrades are carried out.

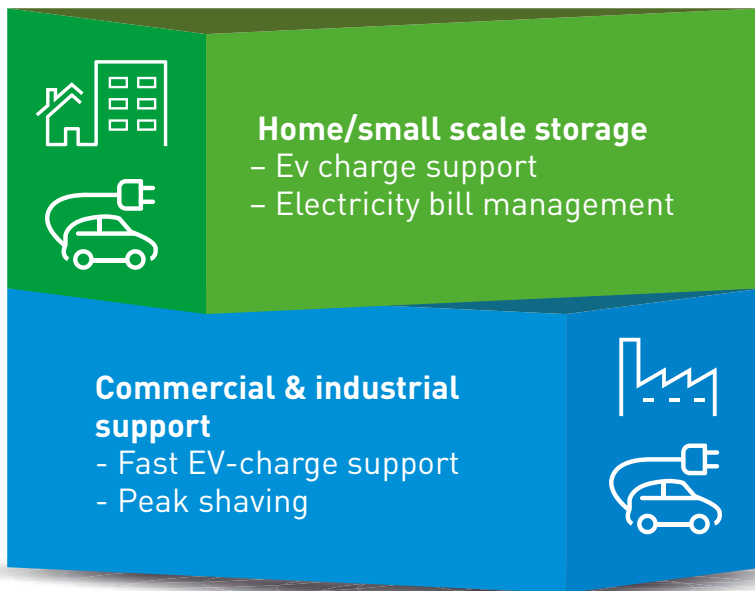

Benefits in brief:

- Safer than "safe"¹
- Environmentally-friendly
- Fully recyclable
- Long service life
- Wide temperature range
- Maintenance free

Advanced energy storage:

- Small scale storage
- Commercial & industrial storage
- EV-charging
- Uninterruptible power supply (UPS)

1) Nilar provides battery systems that are safer than many so called "safe" solutions available on the market. The Nilar battery system contains water based, nonflammable electrolyte. It does not generate short circuit failure even under low temperature charging. The electrodes cannot ignite spontaneously and will not cause heat propagation between modules. That's why we argue that we are safer than "safe".

Nilar Applications

Smart grid applications

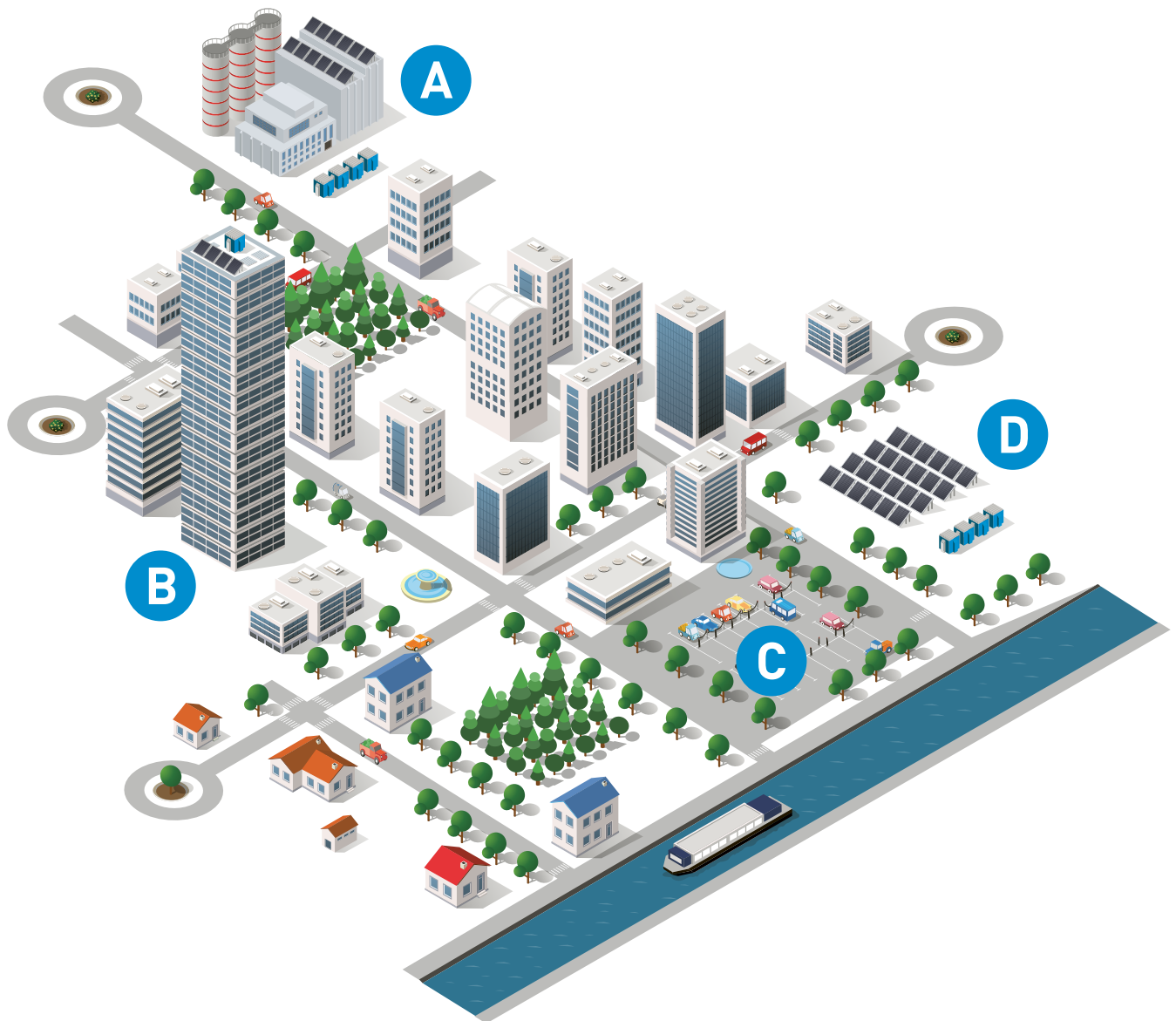

A. Renewable energy storage – Zero emission, micro grid solution for industrial application

B. Energy storage for smart offices – Interconnected energy management system with bi-polar technology

C. Re-conceptualising shopping malls – Energy conservation for a greener shopping environment

D. EnergyHub – Intelligent energy management of solar power with effective storage

Applications

One single Nilar EC battery pack can store 1,44 kWh of energy and charge and discharge multiple times per day without impacting performance. With our powerful and compact solution we provide more energy at a lower cost, when and where it's needed.

Home & small scale storage

Nilar offers small to medium scale solutions that are ideal for safe energy storage in homes, businesses, apartment blocks and housing estates. When connected to solar or wind power stations you get full advantage of the intermittent nature of sustainable energy. The combination of Nilar's smart Battery Management System (BMS) and our energy compact batteries delivers the ideal energy buffer to boost grid supply during busy and peak periods in order to lower tariff fees.

The Nilar solutions gives you the possibility to take control of your energy consumption, also known as Electricity Bill Management.

Commercial support

According to the European Environmental Agency, energy consumption will increase dramatically over the coming years. Thousands of cars will be charged simultaneously in relatively concentrated areas. To prepare for this, Nilar offers energy storage solutions for reliable EV-charging while relieving stress on the grid.

Fast EV-charging requires powerful energy storage solutions that enables tariff fee reductions while delivering peak-shaving capabilities. The Nilar solutions are reliable and able to handle continuous charge and discharge for years to come. Many stations will be located in busy, well-populated areas, for which the safer Nilar solutions are suitable. For environments with fluctuating climates, the use of Nilar batteries is advantageous with its ability to operate in a wide temperature range. In addition, Nilar provides you with environmentally-friendly solutions.

Industrial support

With electricity prices fluctuating throughout the course of the day, utilizing energy stored during low-tariff fee periods can deliver considerable savings. With the right energy storage system and an understanding of the tariff fee structures of energy providers creating strong financial viability, production plants can run the way they were intended, at a lower cost.

For further savings an energy storage solution can be connected to sustainable energy sources. Energy will only be transferred from the grid at off-peak times if the intermittent sources have not provided enough energy for full charge.



Nilar bi-polar modular design

The 12 V Module is the building block of Nilar battery packs. As a building block, it provides excellent flexibility in battery pack voltage together with easy sizing towards different requirements and monitoring for battery management. The patented Nilar bi-polar cell design and electrode technology allows for a high quality and fully automated manufacturing process. The design is comprised of several patented and unique solutions developed by Nilar. The Nilar inventions cover important areas regarding environment, safety, product quality, life and cost. The 12 V module is sealed and contains no screws.

This also contributes to the easy assembling and disassembling. The outer contact plates acts as current collectors for all cells in the module, thus reducing the volumetric overhead and inherently results in a uniform current flow across the cell. This makes it ideal for high discharge rate applications. As a result of this, the bi-polar design has a great advantages compared to the cylindrical and prismatic technologies in terms of volumetric overhead. The uniform current and resistance paths promote uniform heat generation, which enables even ageing of the cells and ensures longer cell life.

The unique and patented Nilar Hydride® battery is based on a bi-polar design, where cells are laid horizontally and stacked on top of one another to gain maximum space efficiency.

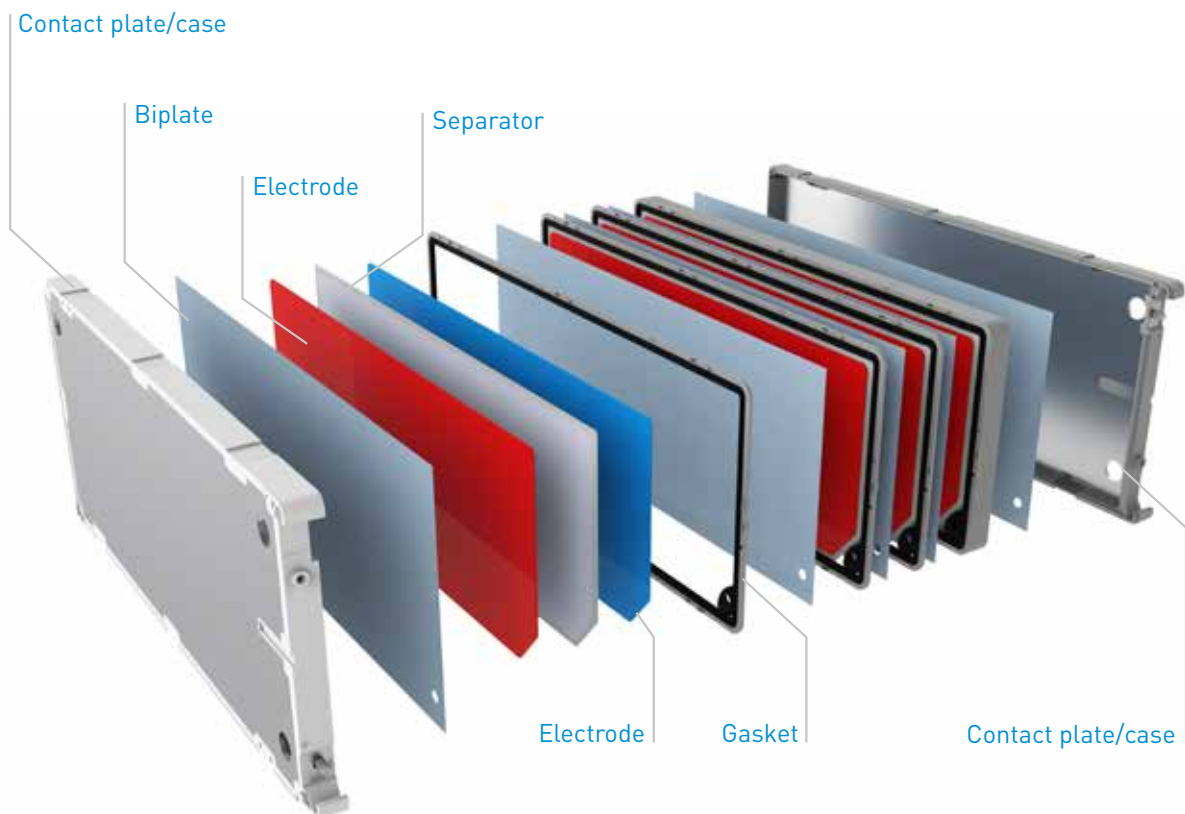

Figure 1.
Battery module expanded view.

Electrodes

The positive and negative electrodes are manufactured by a patented method for compression of dry powders without any expensive plate support material, binders or volatile organic solvents. Active materials and additives, as dry powders, are mixed with each other before being compressed in a calender system to form continuous sheets of compressed electrode material. The sheets of active materials are cut into electrode plates.

The electrode manufacturing process produces electrode with very high accuracy on dimensions, weight and capacity, contributing to the high quality of Nilar battery packs.

Separator

The separator prevents electrical contact between the positive and negative electrodes in the cell while holding the electrolyte necessary for ionic transport. The superior conductivity and safety of the water based electrolyte used in the cells allows for the separator to act as an electrolyte reservoir. The high conductivity of the electrolyte also allows for a relatively thick separator, effectively preventing short circuits from any potential defects in the separator or foreign particles.

Electrolyte

The electrolyte in the cell provides means for ionic conductivity in the cell. The water-based electrolyte has important intrinsic features like low cost, fast filling time and excellent ionic conductivity over a wide temperature range. The electrolyte also possesses attractive safety features such as non-combustibility and energy-absorbing capability.

The electrolyte is a solution of potassium hydroxide. The design is a so-called starved electrolyte design with little free volume of electrolyte in the cells. All of the electrolyte volume is absorbed by the positive and negative electrodes and the separator. The electrolyte will maintain its function over the service life of the battery without refill.

Biplate

The biplates, together with the gaskets, are means for sealing each cell. The biplates also provide electrical contact between cells. In the Nilar bi-polar design the current is perpendicular to the electrode and bi-plate surface, making the whole biplate area used for current transfer between cells. This substantially reduces resistance and optimizes uniformity of current distribution over the biplate and electrode surface. This biplate design is part of the Nilar patent portfolio.

Gasket

Each cell is surrounded by a gasket. The gasket together with the biplates provide a seal between the interior of the cell and the exterior. The hydrophobic properties of the gasket prevent the creation of electrolyte bridges between adjacent cells.

Case

The case is part of the sealing of the module together with the contact plate. The case is extruded onto the sides of the contact plate. The two case/contact plate units on each side of the 10 cell stack are connected by laser welding, forming a sealed 12 V module. Fittings in the case also make sure that all 12 V Modules are aligned when assembled into battery packs.

Contact plate

The contact plate is the positive and negative terminal on the module and is also a part of the module enclosure. The contact plate is made of aluminium. Besides transferring electrical current, the contact plate also serves as a heat conductor moving heat from the cells to the long sides of the 12 V Module. This solution is patented by Nilar and enables efficient and low cost air cooling of battery packs.



The Nilar EC battery pack

Typically, each battery pack contains between 8-12 modules (12V per module). In turn, every module contains 10 battery cells. Nilar battery packs can deliver high discharge power and accept high charge power. At low cycle duty, more charge and discharge power are available, depending on the battery system and application. Battery packs are designed to be used in systems with a maximum battery voltage up to 800 VDC.



Figure 2.
Nilar EC Battery packs.

- Nilar Hydride® bi-polar design enables Nilar to offer safer, more reliable and cost efficient energy storage solutions.
- High energy density with excellent discharge power capability over a wide temperature range.
- The Nilar battery requires very low to no maintenance and is a sealed design with no emissions of gases or electrolyte during its service life.
- The Nilar battery is easy to transport and is not affected by any costly or complicated transport regulations.
- The Nilar battery contains none of the regulated heavy metals mercury, cadmium and lead. The design has been developed to enable a cost efficient recycling process and a high degree of reusable materials.

Nilar EC pack features

Nominal voltage

The cell voltage of a battery cell is governed by the electrochemical potentials of the active materials used in the negative and positive electrodes and the electrolyte. For the hydride system used in Nilar battery packs, the nominal cell voltage is 1.2 V. The Nilar 12 V module is comprised of 10 cells connected in series within the module, achieving a nominal module voltage of 12 V. The nominal voltage of Nilar battery packs is determined by the number of 12 V modules connected in series within the battery pack. Battery packs are connected in series to match the required system voltage, forming a string. The nominal voltage of a string equals the number of battery packs multiplied by the nominal battery pack voltage.

Rated capacity

The battery capacity is rated in ampere-hours (Ah) and denotes the quantity of electricity a fully charged battery can deliver at a 5 h discharge to 1 V per cell at +20°C. Nilar 12 V modules have a capacity rating of 10 Ah. Nilar battery packs are made with a number of 12 V modules connected in series and therefore the rated battery pack capacity is 10 Ah. To meet the required capacity of a Nilar battery installation, the battery packs, or battery strings, are connected in parallel. The total battery capacity is given in multiples of 10 Ah.

Operating voltage

Typical cell operational voltage is minimum 1 V per cell at discharge to maximum 1.6 V during charge. This corresponds to a 10 - 16 V range for the module.

Operating temperatures

The batteries can be operated in temperatures from -20°C to +50°C.

Intermediate state of charge

Batteries can be stored or operated at an intermediate state of charge without loss of performance.

Installation

At normal operating conditions, Nilar battery packs do not produce any emissions; therefore, they require no forced ventilation during operation.

Reliability

The Nilar battery is a stable electrochemical system. The design mitigates corrosion to prevent premature and unpredictable end of life. The design is virtually shock and vibration resistant. Testing shows a graceful decline in performance over the life of the pack.

Storage

Nilar battery packs can be stored several years without loss of performance.

Maintenance

Nilar battery packs use a sealed design that requires minimal maintenance, for many applications no maintenance at all is required.

Service life

Nilar energy storage solutions achieve >2000 cycles.



Figure 3.
Front view of battery pack.

Nilar EC design

The bi-polar design enables Nilar to produce modular batteries with improved volumetric power density and simplified battery construction. The modular concept makes it easy to match packs to different design requirements and to refit existing batteries to new demands in run-time or power. The main advantage of the bi-polar design utilized by Nilar is the common and shared large area current collector. This important feature reduces the volumetric overhead and inherently results in uniform current flow across the cell. Uniform current and resistance paths promote uniform heat gradients over the electrodes. A uniform battery temperature promotes a uniform electrochemical aging of the electrodes in the modules, which translates into a long service life.

Nilar battery packs are optimized for installation in large format energy storage systems. The batteries can be installed in cabinets or racks. A battery management system is integrated on the battery packs together with industrial connectors for electrical and communication interfaces. The electronic battery pack system, communication bus and the battery pack are designed to fulfil requirements for electrical safety in battery systems with a nominal voltage up to 600V.



Figure 4.
Battery pack expanded view.

Pack design

The pack design achieves a compact assembly of cells and other components required in a battery pack to meet required system voltage and run-time. A typical pack consists of 12 different types of components, assembled to a pack by a pick and place manufacturing process, followed by electrolyte filling and formation by a few cycles of charging and discharging to activate the electrochemical system in the cells.

End-piece

There is one end-piece on each side of the battery pack. Together with the steel bands the end-pieces provides uniform cell compression over the electrode surfaces, impact protection to the cell stack and electrical insulation from the pack potential.

The end-pieces also serves as a support structure for the electronic battery pack monitoring system mounted on one of the end-pieces.

Integrated monitoring unit

The integrated monitoring unit (IMU) is an electronic monitoring system, enclosed in a case and attached to the battery pack end-piece. The IMU monitors the conditions of the battery pack and communicates the measured data to the PLC.

Pressure sensor

The integrated pressure sensor enables recording of battery pack pressure. This signal is used for battery pack diagnostics and for high precision charge management. The risk of venting by overcharging the battery pack is eliminated by this unique feature.

Rupture disc

The Nilar battery pack is fitted with a rupture disc located on the rear side of the battery pack that is activated at a pressure of 7 bar. During normal and mildly abusive conditions, the battery pack is sealed with no emission of gases or electrolyte. In normal operation the internal pressure of the Nilar battery pack is below the activation pressure of the rupture disc.

Module

The 12 V module is the building block for all Nilar batteries. The 10 cells are connected in series to create modules with a rated capacity of 10 Ah and nominal voltage of 12 V.

Contact plate

The contact plate electrically connects the adjacent modules in the pack and thus eliminates the need for external connectors between modules.

Cooling

The patented integrated cooling solution has optimized heat dissipation from the long sides on the battery pack, allowing for easy and low cost air cooling with minimal increase in system volume and low fan power.

The patented design has the heat conducting from the contact plates to the long side surface of the 12 V module, where stacked modules increase the effective surface area for air cooling.

Nilar System Solutions

Function description

An energy storage from Nilar consists of innovative and environmentally-friendly batteries that are based on a bipolar modular battery solution. The modules, in turn, can be assembled into battery packs of different capacity (Ah) and/or voltages (V) in a very simple stacking operation. These battery packs are arranged in string configurations, where each string is controlled and isolated by fuses and connectors in an IT installed set up. To maintain a long service life, Nilar Electric Energy Storage (EES) is equipped with a Battery Management System (BMS). The BMS monitors the batteries state-of-charge (SoC), when the system is fully charged, when the capacity is low and protects the batteries from becoming overcharged or undercharged. The BMS informs the Energy Management System (EMS) via a fieldbus communication protocol, which can be configured to Modbus RTU, Modbus TCP IP or CANopen/CAN. The BMS sends information about recommended charge and discharge power, provides the EMS with SoC, warnings (near limits) and alarms (beyond recommended limits).

- **The main components of Nilar energy storage systems are:**

- Nilar Battery Management System (BMS)
- Nilar battery packs with integrated monitoring units
- Current sensors
- Programmable logical controller
- Circuit breakers
- Fuses

- **Communication interfaces**

The Nilar BMS can be configured to communicate by:

- Modbus TCP IP
- Modbus RTU
- CANopen/CAN

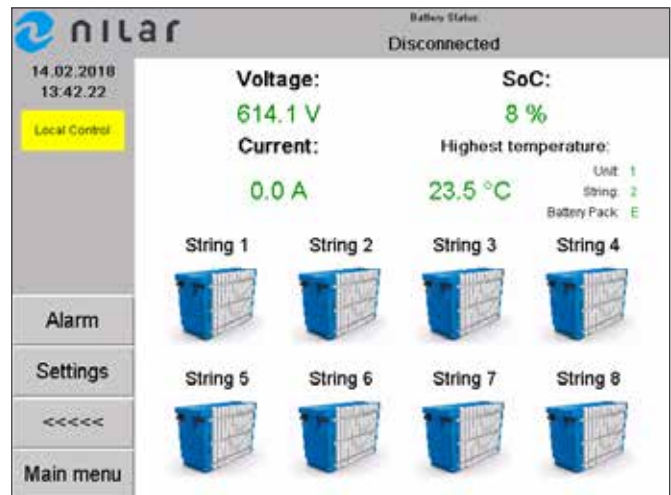

Figure 5. Example of the Nilar Human Machine Interface (HMI) with a configuration of 8 battery strings.

- **System voltage**

Nilar energy storage solutions can be configured for nominal voltages between 96 to 600 VDC with an operating voltage window between 10% below and 25% above nominal voltage

- **System documentation**

Nilar provides all necessary documentation to integrate the system into an existing EMS of the customer.

Documents provided:

- Function description
- Installation and maintenance manual
- System specifications

Nilar battery management system

Battery Management System schematic overview

The EES is controlled by a Battery Management System (BMS) that protects and controls the batteries to maintain a long service life. The BMS includes Programmable Logic Controller (PLC), Human Machine Interface (HMI), fuses and contactors in a master set-up. Each battery has its own integrated monitoring unit (IMU) that communicates via an isolated communication bus to the PLC system. The EES can be scaled up in order to cater the energy demand depending of the required capacity for the application. The maximum number of units an EES can be extended to is four (4) units, one master BMS (HMI/PLC) and three (3) slaves (PLC). Each PLC can handle up to 40 monitoring units which gives an energy storage capability of up to 57,6 kWh per PLC. The monitoring unit is placed on each battery pack and connected to the PLC by insulated CAN communication. In multiple configurations (more than one unit), the HMI is collecting all data from the batteries and provides an easy access for the EMS with just one access point. Further information about the BMS functions and interface data can be found in the documentation Nilar Function description, which is provided by Nilar upon request.

Energy Management system overview

The Energy Management System (EMS) is a higher level system that monitors, controls and optimizes the performance of the energy system. The EMS communicates with the BMS and commands the BMS by signals. The signal descriptions can be found in the Nilar Function Description, which can be provided upon request.

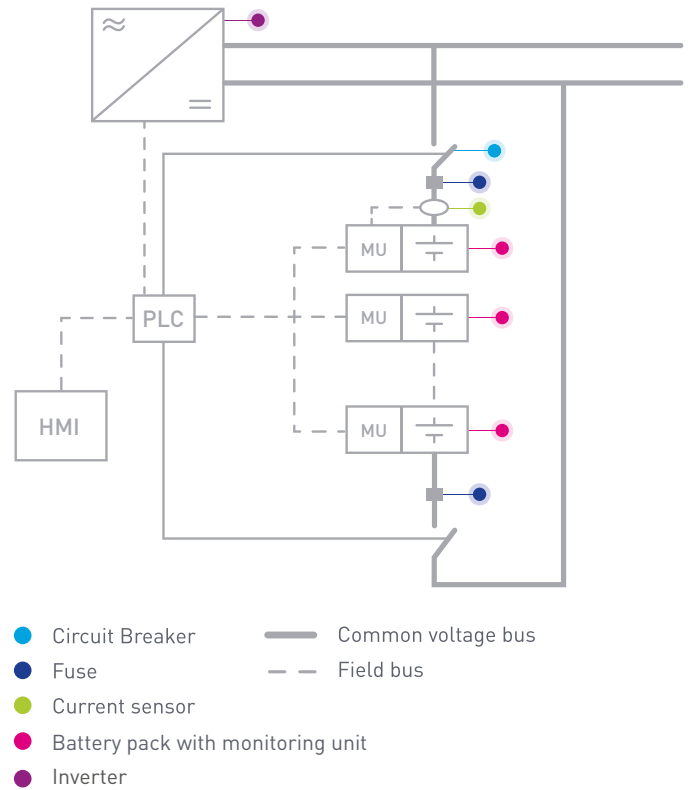

Figure 6.
BMS schematic overview.

Nilar EC System configurations

The Nilar energy storage system solutions can be configured according to different setups, creating flexibility towards customers and a user-friendly experience.

To enable the Nilar Energy Storage System to operate according to the following specifications, an inverter is required to handle charging and discharging of the energy storage and for the conversion between AC/DC. Nilar can assist you upon request to find the correct inverter to match your Energy Storage System.

An EMS is also required to the demanded energy input or output from the Energy Storage System according to application demands via the BMS. The inverter can be controlled by the Nilar BMS or the EMS.



System configurations

- Flexible solution
- Dynamic solution
- Basic solution

Flexible solution

The EMS sends signals to the BMS asking if it can start charging or discharging with the demanded amount of power [kW]. The BMS can in turn answer Yes, No or Standby. If the BMS gives the answer Yes or No, the EMS will communicate this to the inverter and decides when to start charging or discharging.

EMS controlled inverter

- Open integration
- Customer inverter control
- Customer system control (EMS)

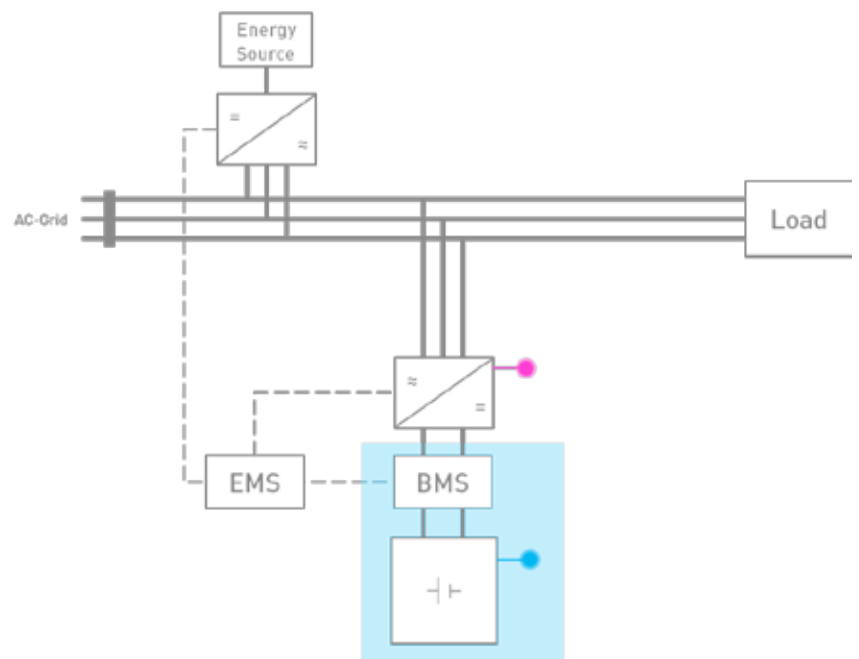
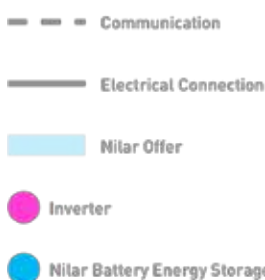

Figure 7.
Flexible solution configuration scheme.

Dynamic solution

The EMS sends signals to the BMS, asking if it can start charging or discharging with the demanded amount of power [kW]. The BMS in turn can answer Yes, No or Standby. If the answer from the BMS is Yes or No, the BMS will communicate this to the inverter and decides when to start charging or discharging.

- BMS controlled inverter**
- Nilar chosen inverter
 - Nilar inverter control
 - Customer system control (EMS)

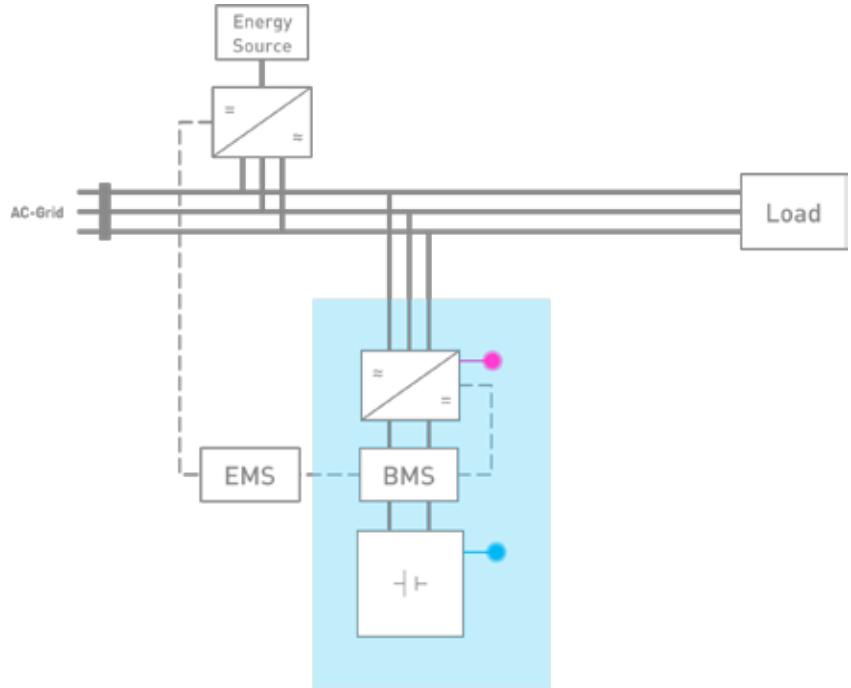
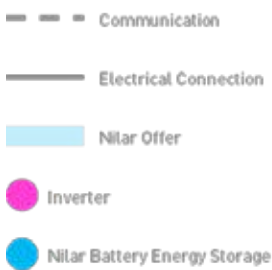

Figure 8. Dynamic solution configuration scheme.

Basic solution

In a Basic solution the BMS receives signals from the energy meter. The single functionality of the energy meter is to show if energy is flowing towards the grid or towards the load. The BMS can then decide if the Nilar battery system should charge or discharge, depending on the production of the energy source and the load.

- Stand alone system solution**
- Energy meter
 - Nilar inverter control
 - Nilar system control

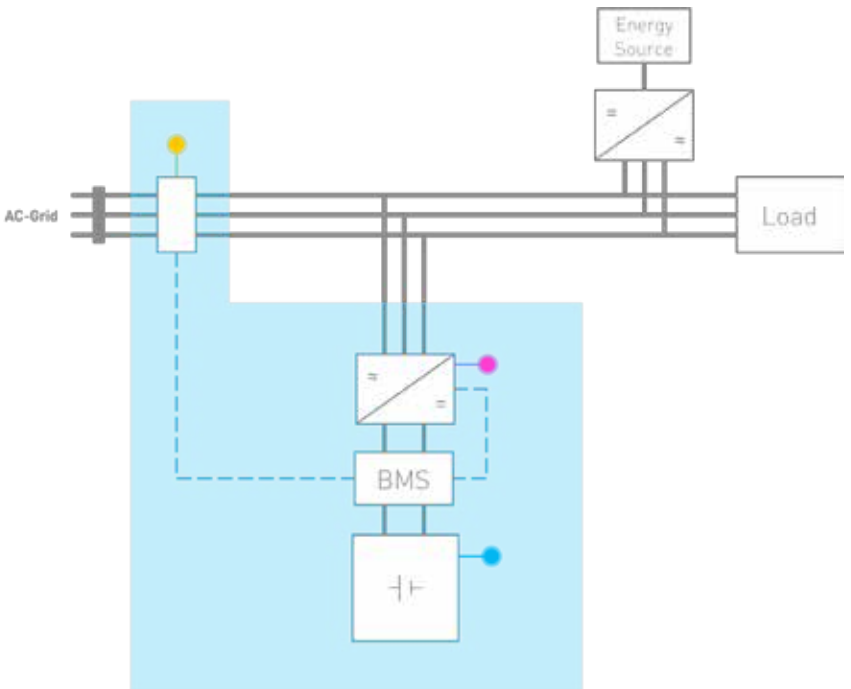
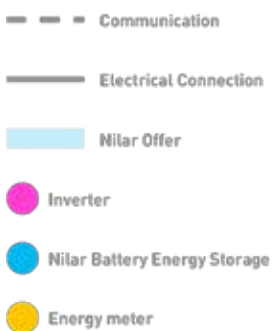

Figure 9. Basic solution configuration scheme.

Electrochemistry

The Nilar Hydride® bi-polar battery module (NiMH) consists of ten cells in series. Each cell contains two electrodes (a positive and a negative), electrolyte, and a separator in-between the two electrodes. The table below describes the compounds in the cell that are active during charge and discharge of the cell.

The electrolyte is involved in the chemical reactions at the electrode surface together with the active material during charge and discharge, but is not consumed by the reactions. The strength of the electrolyte is not changed during any of these modes.

	Charge products	Discharge products
Positive material	Nickel (III) oxyhydroxide (NiOOH)	Nickel (II) hydroxide (Ni(OH) ₂)
Negative material	Metal hydride (MH)	Metal alloy (M)
Electrolyte	KOH	KOH

Discharge

When the battery is discharged, hydrogen moves from the negative active material (MH) to the positive active material (NiOOH). In this process, the metal hydride (MH)

is drained of hydrogen and the positive active material is reduced to Nickel hydroxide (Ni(OH)₂).

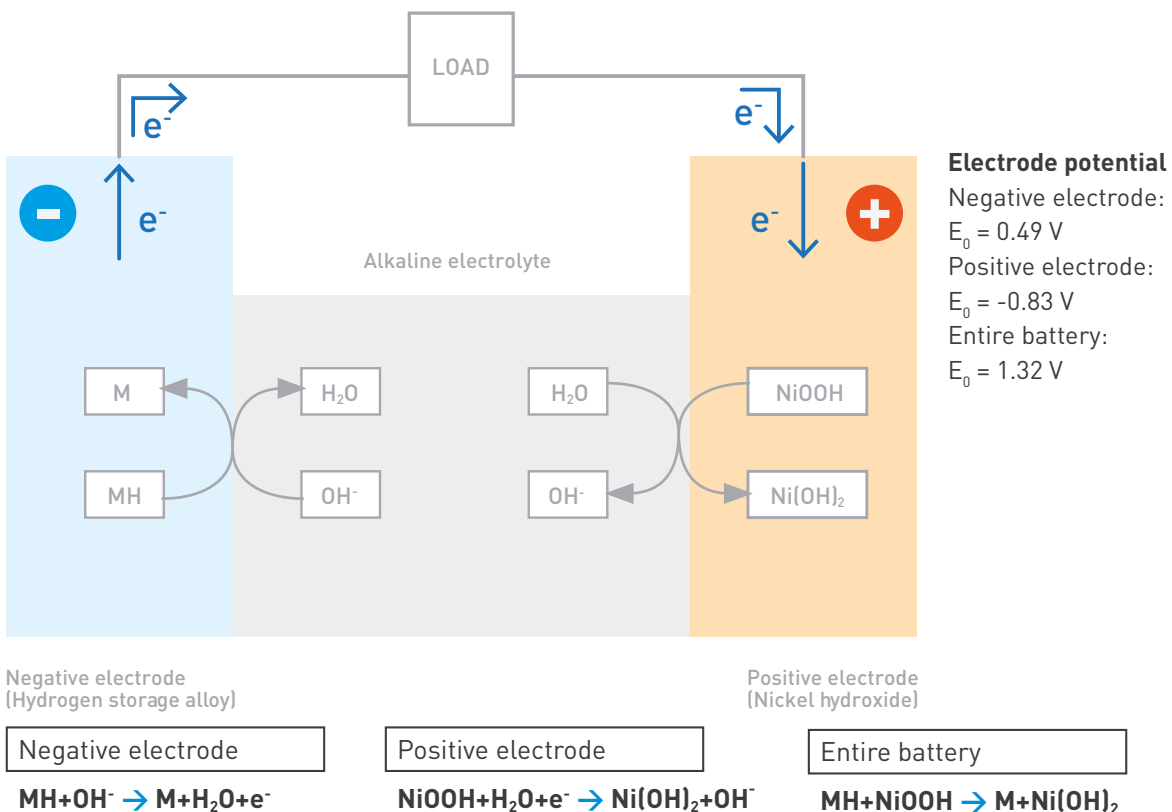

Figure 10.
Electrochemical reaction during discharge.

Charge

During charge, the hydrogen moves in the opposite direction as compared to the discharge. As the battery is charged, Nickel hydroxide ($\text{Ni}(\text{OH})_2$) in the positive electrode lose hydrogen and the metal alloy (M) take up hydrogen to form a metal hydride (MH). When losing

hydrogen, the Nickel hydroxide ($\text{Ni}(\text{OH})_2$) oxidizes and the positive active material becomes Nickel oxyhydroxide (NiOOH).

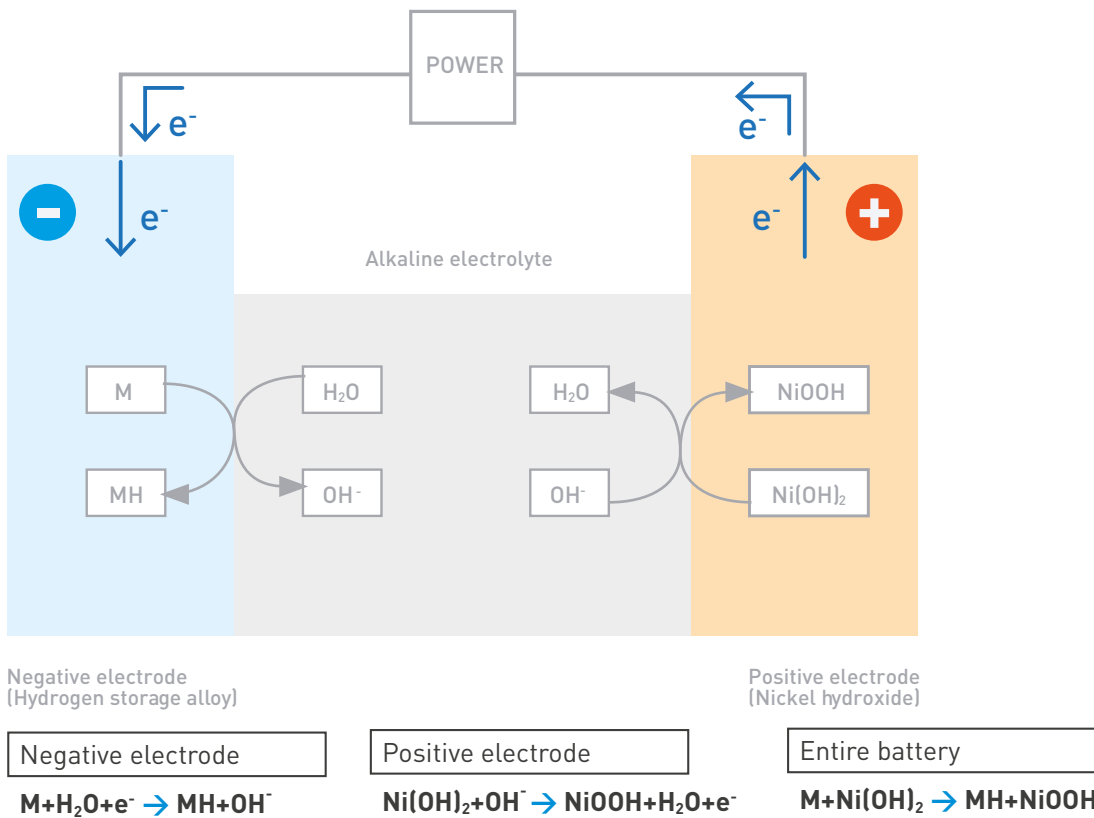

Figure 11.
Electrochemical reaction during charge.

Operating features

Discharging

Discharge performance

After a moderate initial voltage drop the discharge voltage is stable over more than 80% of the discharge and ends with a distinct knee at end of the useful capacity. Discharge voltage is dependent on discharge rate, temperature and the state-of-charge. The discharge voltage decreases with increased discharge rates and decreasing temperature. The discharge performance is affected moderately at elevated temperatures, but at low temperatures the effect of temperature on discharge performance is more pronounced due to the increase in resistance. The discharge capacity, or the run-time to end of discharge, is mainly affected by discharge rate and temperature. Delivered capacity depends on the selected discharge cut-off voltage and decreases with increasing discharge cut-off voltage.

Test currents are expressed as multiples of the rated capacity value denoted by "C" [e.g. a discharge current of 2C for a Nilar battery pack with a rated capacity of 10 Ah equals 20 A).

Discharge rates

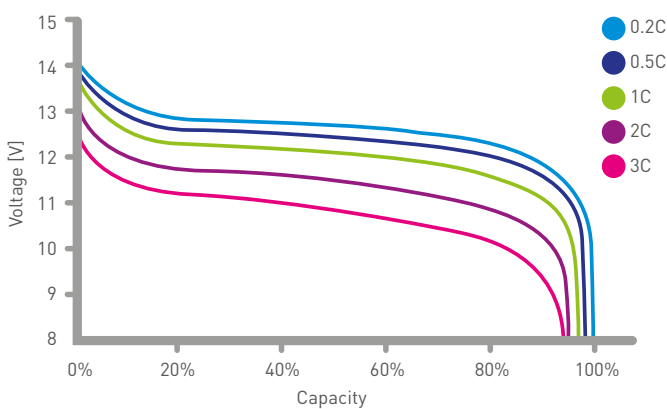

Figure 12. Typical voltage profiles for constant current discharges with various discharge rates. Charging and discharging made at +20°C.

Discharge temperature range

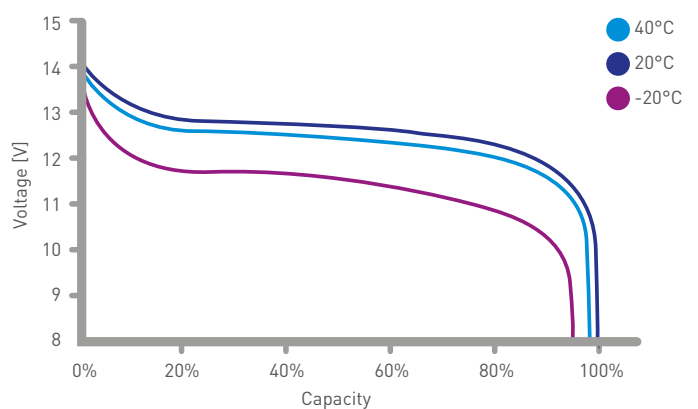

Figure 13. Constant current discharge with 0.2C at various temperatures. The battery was fully charged at +20°C, acclimatized for 12 h at test temperature and then discharged.

Discharge cut-off voltage

It is recommended to terminate discharge on a preset minimum allowed voltage to optimize performance and life of the battery. With proper settings for the end of discharge voltage (EODV), utilization of capacity is optimized and risk of detrimental deep discharge of individual cells or modules is minimized.

EODV is a function of discharge rate, battery size and environmental conditions. Lower cutoff voltage can be used at low temperatures and high discharge rates for better utilization of the capacity. Deep discharge, and especially reversed polarity, will have a detrimental effect on the performance.

Discharge resistance

The resistance varies with temperature and state of charge. At +20°C the optimum resistance is achieved between 80 to 30% state of charge. Below 20% state of charge the resistance increases significantly. The resistance increases with decreasing temperature.

Discharge capacity over temperature range

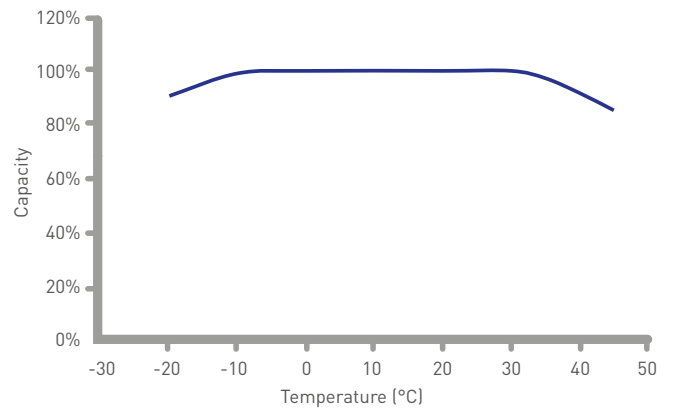

Figure 14. Constant current discharge capacity at various temperatures. The battery was fully charged at +20°C, acclimatized at test temperature for 12 h and then discharged with 0.2C to 1 V per cell at test temperature.

Discharge cut-off voltages

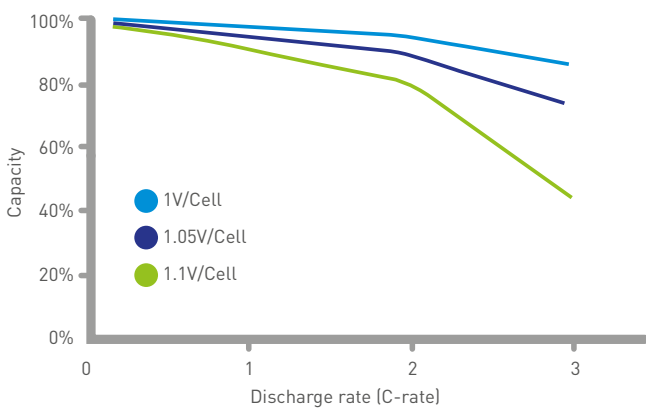

Figure 15. Available constant current discharge capacity for various discharge cutoff voltages. Constant current discharge with 0.2C at +20°C.

Resistance, temperature range and charge levels

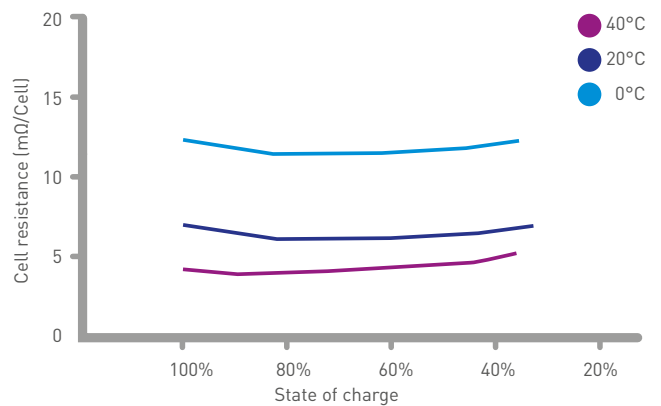

Figure 16. Cell resistance at various temperatures and charge levels. 30 seconds pulse duration and a discharge pulse current of 3C.

Charging

Recommended charge procedure

The recommended charge procedure is constant current charge with charge termination based on rate of temperature increase (dT/dt), together with a maximum allowed pressure and pack temperature. Nilar battery packs can be charged with power ranging from zero up to fast charging with 3C. As a standard charge, the recommended charge rate is 0.3C with a rise in temperature, dT/dt , corresponding to 0.3°C in 2 minutes. The charge procedure can be used for charging battery packs with battery pack temperature in the range of -20°C to +50°C. Within this temperature range, a fully discharged battery is recharged within 3.5h. Charging shall be terminated when either the maximum allowed battery pack temperature or pressure is reached, which are 58°C and 5.5 bar, respectively.

An inherent feature of the Nilar Hydride® electrochemical system at charging is the build-up of pressure and temperature at the end of the charge. The unique battery pack pressure sensor, integrated in Nilar battery packs, together with measured battery pack temperature, are efficient means to secure charge termination over the whole temperature and power range. At low temperatures the charge rate can be limited by an increased voltage. At elevated temperatures the maximum charge rate is limited by the rise in temperature and pressure at end of charge.

Cell balancing

For a battery in service, the cells in the battery will settle at various charge levels over time. This is due to temperature gradients in the battery causing small variations in self discharge rate and impedance. The result is reduced run-time and, in extreme cases, accelerated ageing of the battery due to deep discharge or overcharge of individual cells in the battery. Balancing of cells in Nilar battery packs can be achieved simply by a limited overcharge allowing the low capacity cells to become fully charged. Heat generated at overcharge is detrimental to the performance and has to be considered in the charge procedure. Cell balancing is included in the electronic charge solutions provided by Nilar.

Typical terminal voltage, pressure and temperature when charging a 12 V / 10 Ah Nilar battery pack at +20°C with a constant current charge rate of 0.2C is shown in Figure 17.

Charge characteristics

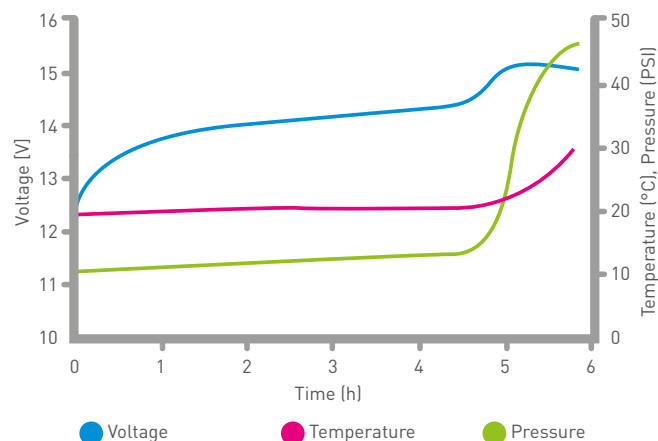

Figure 17.

Typical charge characteristics at +20°C. Constant current charging with 0.2C.

Self discharge

The state of charge of a Nilar battery pack during storage slowly decreases with time due to self discharge. The self discharge is caused by internal electrochemical reactions that slowly discharge the battery. The self discharge rate is high over the first days of storage, but then levels out to a few percent per month depending on temperature. The rate of self discharge is increased at elevated temperatures and decreases at low temperatures. A fully charged Nilar battery pack stored at +20°C will lose about 6% capacity after one day and 13% capacity after 28 days. Parasitic loads on the battery from charger, load and electronic systems will increase the rate of capacity loss during storage. This is common with all Hydride (NiMH) chemistries.

Cycle life

Cycle life is the number of charges and discharges a battery can achieve before the discharge capacity drops to a predetermined capacity. A number of circumstances have to be considered when estimating cycle life. Among the most important are temperature, charge method, charge

and discharge rates, depth of discharge and environmental aspects. The largest impact on the cycle life comes from the battery pack temperature, the charge procedure, and the depth-of-discharge (DoD), which is the state-of-charge (SoC) operating window. The more shallow a battery is cycled, the higher the number of cycles until the battery is unable to sustain the required service.

One of the superior features of Nilar batteries is the very stable performance over life. Typically, the impedance of a battery increases when the battery is used. This results in reduced run time and finally, depending on how end of life is defined, the battery is not able to perform as required. The stable and well defined performance over life experienced with Nilar batteries is a consequence of the intrinsic features of the Nilar Hydride® technology together with the

high manufacturing quality gained by the Nilar patented bi-polar design. The main ageing mechanism is dry-out, causing a slow increase in impedance over cycles. Capacity is not deteriorated during cycling. Nilar Hydride® batteries can be stored for many years without loss of performance. There is no decomposition of the electrolyte at full charge nor solid electrolyte interface consuming charge carriers with detrimental effect on capacity and impedance. Cell impedance in a Hydride (NiMH) cell is determined by the amount of electrolyte in the separator. Over time, the electrolyte in the separator decreases (dry-out) with a slow decrease in conductivity. Finally, depending on the load, the run time of the battery is down to a level where the battery is considered as spent. End of life is often defined as 80% of initial capacity but can be based on other application specific constraints or capacity levels.

Self discharge over various temperatures

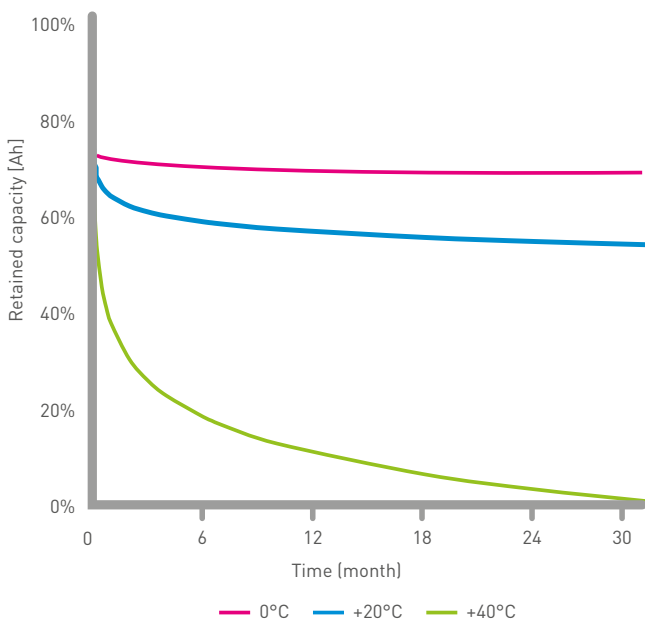

Figure 18. Self discharge when charged to 75% SoC. Typical charge retention at +20, +40 and 0°C at various storage periods.

Cycle life as a function of SoC-window.

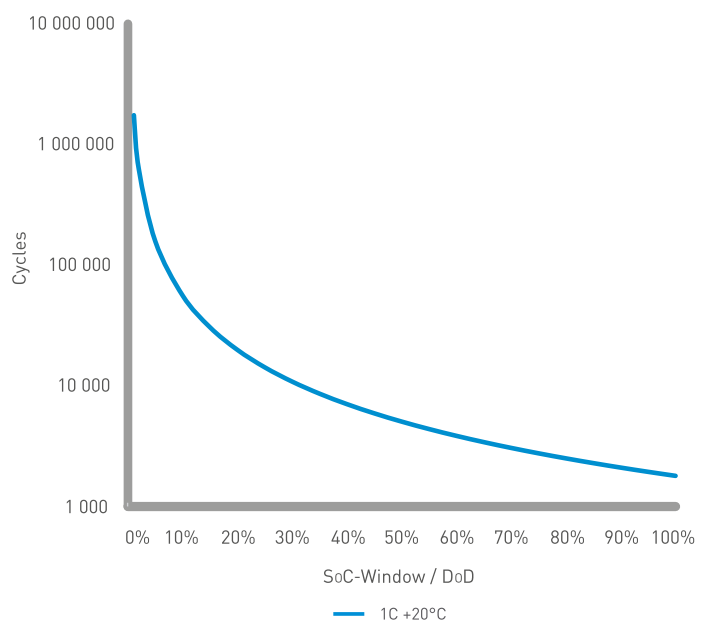

Figure 19. Cycle life as a function of SoC-window.

Safety

Nilar Hydride® batteries are based on a mature technology that has been used commercially for over 25 years for a variety of applications including consumer products, electric vehicles, hybrid electric vehicles, and stationary power applications. The introduction of batteries into cars are now driving the safety regulations both for vehicles and other battery applications, such as energy storage.

The main safety benefits of Nilar batteries are:

- Battery system with water based, non-flammable electrolyte⁽¹⁾: No risk of spontaneous fire or explosion.
- No risk of short circuit generation even under low temperature charging as observed in other solutions: No risk of spontaneous release of energy, rapid temperature increase with fire and explosion as potential consequences.
- Electrodes contained in Nilar modules cannot ignite or react spontaneously: No risk of heat propagation between modules under normal operation and rest periods⁽²⁾.

A significant part of the Battery Management System (BMS) functionality is to keep the battery from states which may affect reliability and safety. This mainly concerns the prevention of overcharge, over-temperature and short circuits.

But even in the case of BMS failing or malfunction, Nilar batteries show a high degree of passive safety under abusive treatment⁽³⁾:

- **Overcharge:** The Nilar systems can manage an overcharge with 0.2C for 5 hours, or with 1C for 30 minutes without venting. During overcharging with higher current over longer periods of time, the maximum pressure limit of 5.5 bar might be exceeded and, consequently, the safety vents could open, releasing gas.
- **Over-discharge and reversal:** Over-discharge of modules down to 0 V is not critical for safety since it does not cause a pressure nor a temperature increase. However, it does damage the battery beyond use and should be avoided. Continuous reversal can lead to an internal pressure build-up, activating the safety valves and causing a gas release. Any associated temperature increase will be modest and non-critical.
- **Short circuit:** To prevent short circuit, Nilar has installed fuses on both the positive and negative side of each string.
- **External heat / fire:** If an external fire would occur near the battery bank, the fire should be extinguished by water or CO₂, in the same way as a corresponding electronics fire. If the fire is not extinguished, the heat will eventually cause the Nilar batteries to ventilate. This scenario should be addressed in the same way as a corresponding fire in a lead-acid battery installation.

(1) Electrode materials in Hydride batteries (NiMH) are chemically stable when in contact with the electrolyte. There are no heat generating reactions taking place between the electrode materials and the electrolyte and no solid electrolyte interface is needed to protect the electrolyte from electrode materials. This can be compared to chemistries containing highly flammable organic electrolyte. If the organic electrolyte is catching fire, explosive and poisonous gases are released.

(2) Propagation is a dangerous phenomenon that can occur in batteries based on other chemistries, where one cell that has run into thermal runaway can spread the heat to other cells, in that way initiating thermal runaway in other cells and causing a cascade effect.

(3) Several battery chemistries require a very strict safety region when it comes to upper voltage limits, temperature limits and current limits. If you pass the set limits you enter the safety critical region where thermal runaway can be triggered by internal short circuits and/or external heat. For example, during deep discharge or overcharge.



Nilar batteries are also certified for transport via road, rail, sea or air, without the need for heavy and expensive explosion-proof containers.

Transport

One of the advantages with Nilar battery packs, as compared with many other battery types, is that UN approved packaging and marking is not required for transport by sea, road, rail and air.

No dangerous goods documentation is required when transporting Nilar battery packs by road or rail.

A dangerous goods declaration is required if batteries are transported by sea in quantities of over 100 kg in one transport unit. Nilar battery packs are then defined as dangerous goods, class 9. UN number and Proper Shipping Name are UN 3496 and Batteries, Nickel-Metal Hydride respectively.

Transportation of Nilar systems is easy to manage, since the IMDG Code provisions do not apply on Hydride batteries (NiMH) contained in or packed with equipment, according to Special Provision 963.

An Air Waybill or similar is required if batteries are transported by air. Nilar battery packs are not classified as dangerous goods and belong to the entry "Batteries, dry" in the list of dangerous goods in IATA (no UN number). If an Air Waybill is used, the words "Not Restricted" and the Special Provision number (A123) must be included in the description of the substance on the Air Waybill, according to IATA-DGR.

For several other battery chemistries, heavy regulations apply for all modes of transport, especially regarding transport by air. For those classified as fully regulated dangerous goods, strict regulations and even training courses may be required for the personnel involved in the transportation.

Standards:

- Transport UN38.3 Test T1 Altitude & Test T3 Vibration
- Transport ADR-S SP238 Test A



Sustainability



Nilar EC batteries are made with minimal hard-to-recover raw materials. Unlike most industrial batteries, Nilar Hydride® batteries do not contain, nor need cadmium, mercury or lead to deliver powerful results. And unlike many other chemistries, which are often more costly to recycle than mine, nickel is an actively recycled and reused material.

Nilar batteries are fully recyclable. From the nickel used to power them to the seals and casing used to the contact plates transferring the energy, the different elements that make up the battery can be reused in industrial manufacturing, such as the production of new Nilar batteries. The Circular Economy philosophy has been a central part of the R&D process for Nilar EC, reducing cost and the environmental impact of the batteries.

Handling of battery waste in Europe is regulated according to Battery Directive 2006/66/EC and EU Member state national legislation. Nilar takes full responsibility for taking back Nilar batteries and for the recycling process of them. Returned batteries are systematically recycled and the materials are re-used either in new batteries or in other industries.

Nilar innovations for high recycling efficiency:

- Developed method for the re-use of battery material in our production line.
- Fully recyclable
- Low usage of hard to recover raw materials

When your Nilar battery is ready for disposal it is recommended to send the battery to the local Nilar battery dealer or to Nilar AB.

Nilar products are compliant with the following directives and regulations:

- EU-directive 2006/66/EG ('Battery Directive'). The batteries do not contain the heavy metals mercury or cadmium.
- Waste Electrical and Electronic Equipment (WEEE) Directive 2012/19/EU
- Restrictions of certain hazardous substances according to RoHS Directive 2011/65/EU.
- Nilar products are in compliance with Regulation (EC) No. 1907/2006 concerning the Registration, Evaluation, Authorization and the Restriction of Chemicals (REACH).

Nilar system components

Battery system components

Each EES consists of several battery strings, with battery packs connected in series to match the required system voltage. To meet the required energy content, battery strings are connected in parallel. Strings are fitted with circuit breakers on both sides of the string and one current sensor for monitoring of charge and discharge currents.

The following components are found in a battery string (example based on a battery string consisting of 4 battery packs):

- Battery packs with monitoring units (4pcs)
- Circuit breakers (2pcs)
- Current sensor (1pcs)
- String fuses (2pcs)
- RJ-45 network cables (5pcs)
- 24VDC power cable for IMU (1pcs)
- String power cables (5pcs)

EMC standards:

IEC 61000 -4-2:2009, -4-4:2012, -4-5:2006, -4-6:2009, -4-3:2006 + A1 + A2, 61000-6-3:2007 + A1

Electrical cabinet standards:

IEC 61439-1 & -2

Batteripack standards:

- Safety : IEC 62485-2
- Performance: IEC 62675
- Transport UN38.3 Test T1 Altitude & Test T3 Vibration
- Transport ADR-S SP238 Test A



Figure 20.
Cabinet 11,5 kWh cross-section view.

Integrated monitoring unit

The integrated monitoring unit (IMU) is mounted on each battery pack. The unit is monitoring potentials for every 10 cells in the pack together with pack temperature and pressure. Processed data is communicated via a field-bus interface to the PLC. The integrated monitoring units are powered by an external power supply of 24 VDC (not from the pack). The communication between the PLC and the integrated monitoring unit is a CAN bus using the CANopen application programming interface. CANopen uses ISO-11898:2003 standard CAN with an 11-bit identifier. The range of bus signalling rates is 125 Kbps to 1 Mbps. The monitoring unit bus rate is set to 250 Kbps.

Signals IMU

The following signals are monitored by the IMU. The IMU is tested according to standard IEC 61010-1.

- **Module voltages**

The voltage monitors detect the voltage of each module. If the actual voltage is out of the defined range an alarm will be triggered. In addition to the module voltages, the combined voltage of the battery pack is also measured and presented as a total voltage value.

- **Current**

The current sensor gives information about the current flow direction and value. If the current is out of the defined range an alarm will be triggered.

- **Pressure**

An internal battery pressure sensor measures the relative pressure in each battery pack. Due to the common gas space in the Nilar bi-polar pack design, all the cells in the battery pack have the same pressure. If the pressure is out of the defined range an alarm will be triggered and communicated to the external battery management system. The external battery management system is programmed to disconnect the battery pack if it reaches the pressure limit.

- **Battery temperature**

There is one temperature sensor in each battery pack that measures the temperature. If the temperature is out of the defined range an alarm will be triggered and communicated to the external battery management system to prevent the battery from overheating. The communicated information also has the purpose to detect when a full charge cycle is completed.

- **Fan**

The settings for the fan can either be adjusted as a 0-100% speed or as a target temperature. These settings are defined in an external battery management system.

BMS

Nilar BMS is based on specific characteristics of Nilar battery packs and is developed to optimise utilisation of installed battery capacity and service life. The BMS will issue warnings or alarms to higher level systems when battery conditions are out of range. If critical conditions are detected in a string, the BMS will disconnect the string. The settings are optimised by Nilar depending on the system and application.

Programmable logical controller (PLC)

The controlling system that controls the BMS consists of two (2) PLC units and one (1) HMI. It ensures that the battery system runs in a safe way and manages information from the IMU, EMS and the inverter.

The first PLC is the battery system PLC that monitors data from the MUs and controls switching on and off each battery string. The second PLC is combined with a HMI panel. This PLC manages alarms, presents the actual status of the battery system and controls the low voltage inverter. Mutual data is exchanged between the PLCs as well as between the PLC and the inverter. The communication is executed in Modbus.

Circuit breaker

Two circuit breakers per string are required to enable disconnection of the string from the common voltage bus. The circuit breakers are hardwired to and controlled by the PLC. Circuit breakers can be provided on request.

Fuse

Two fuses per string are recommended, one on the negative and one on the positive side and located close to the string.

Current sensor

The current sensor provided by Nilar is an automotive grade current transducer. It has galvanic isolation between the primary circuit (high power) and the secondary circuit (electronic circuit). The open loop transducers use a Hall-effect integrated circuit. There is one current sensor per string, mounted on the battery pack on the negative side of the string.



Figure 21.
Rack 48 kWh and Rack 57,6 kWh.

Insulation monitoring

The insulation monitor is used for an IT- setup installation. The insulation resistance between system lines and system earth is measured. If this falls below the adjustable threshold values, the output relays switch into the fault state. The insulation monitor is an ABB CM-IWN with a coupling unit ABB CM-IVN. The coupling unit is used to achieve a measuring range up to 1000 VDC.

Cut-off contactor

The cut-off contactor is used to open and close a battery string when the BMS signals that the battery string is going to be charged or discharged. The cut-off contactors are placed on both the plus side and the minus side of the battery string.

Fans

Fans are placed on the back of the cabinet in order to cool the battery packs and are controlled by the IMU. The BMS communicates to the IMU which temperature is desired and the IMU controls the fans in order to maintain that temperature. The fans can be of various types, most commonly provided with 24 VDC from the BMS cabinet (other alternatives in the voltage range 12-30 VDC are also possible).



Products

In a common voltage bus system, with a fixed voltage window, the battery capacity required to meet the designed run time of the battery is determined by the number of strings connected in parallel on the common voltage bus. Each string increases the battery rated capacity by 10 Ah. The rated battery energy equals the rated pack energy in Wh multiplied by the number of packs in the battery.

Battery size is determined by a number of application-specific features such as voltage window, load profile, required run time and recharge opportunities. System design should also be considered. For instance, a system supported by photovoltaic arrays will require a different battery size than a hybrid system powered by a combustion engine and

a battery. Charging infrastructure is also important: the number of charging stations or frequency of short recharging together with installed charger power will impact the optimum battery size. Nilar will work with you to determine the appropriately-sized system for your application.

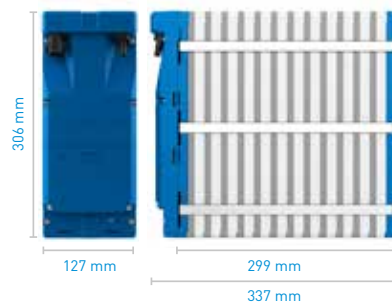

Figure 22. Measurement illustration of 144V battery pack with length incl. and excl. Integrated Monitoring Unit.

BATTERY PACK	Art. nr.	Product description	No. of battery modules	Pack voltage (V)	System voltage (V)	Rated capacity (Ah)	Energy (kWh)	Weight (kg)	Depth (mm)	Height (mm)	Width (mm)
EC-96V-10Ah	20-0010	Battery pack 96V +IMU	8	96	96	10	0,96	23,6	248	306	127
EC-108V-10Ah	20-0011	Battery pack 108V +IMU	9	108	108	10	1,08	26,2	273	306	127
EC-120V-10Ah	20-0012	Battery pack 120V +IMU	10	120	120	10	1,2	28,8	293	306	127
EC-144V-10Ah	20-0013	Battery pack 144V +IMU	12	144	144	10	1,44	34	337	306	127

CABINET	Art. nr.	Product description	No. of battery packs	Pack voltage (V)	System voltage (V)	Rated capacity (Ah)	Energy (kWh)	Weight (kg)	Depth (mm)	Height (mm)	Width (mm)
ECH-576V-11,5kWh	20-0020	Cabinet 11,5 kWh	8	144	576	20	11,5	352	655	1033	701
ECH-576V-17,2kWh	20-0021	Cabinet 17,2 kWh	12	144	576	30	17,2	518	655	1388	701
ECH-576V-23kWh	20-0022	Cabinet 23 kWh	16	144	576	40	23	684	655	1743	701
ECH-576V-28,8kWh	20-0023	Cabinet 28,8 kWh	20	144	576	50	28,8	850	655	2098	701

RACK	Art. nr.	Product description	No. of battery packs	Pack voltage (V)	System voltage (V)	Rated capacity (Ah)	Energy (kWh)	Weight (kg)	Depth (mm)	Height (mm)	Width (mm)
ECI-600V-48kWh-M	20-0024	Rack 48 kWh Master	40	120	600	80	48	1402	615	1996	1509
ECI-600V-48kWh-S	20-0026	Rack 48 kWh Slave	40	120	600	80	48	1402	615	1996	1509
ECI-576V-57,6kWh-M	20-0025	Rack 57,6 kWh Master	40	144	576	100	57,6	1610	615	1996	1509
ECI-576V-57,6kWh-S	20-0027	Rack 57,6 kWh Slave	40	144	576	100	57,6	1610	615	1996	1509

Racks



Figure 23.
 Rack 48 kWh and Rack 57,6 kWh

Cabinets

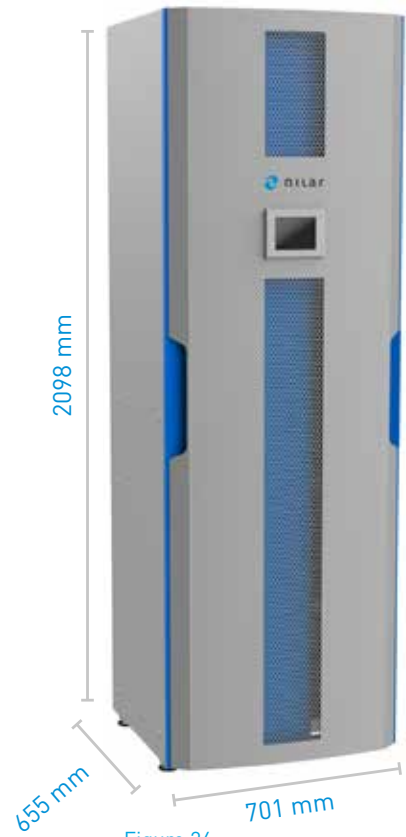

Figure 24.
 Cabinet 28,8 kWh

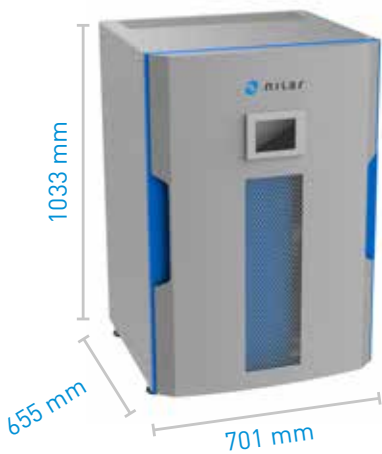

Figure 25.
 Cabinet 11,5 kWh

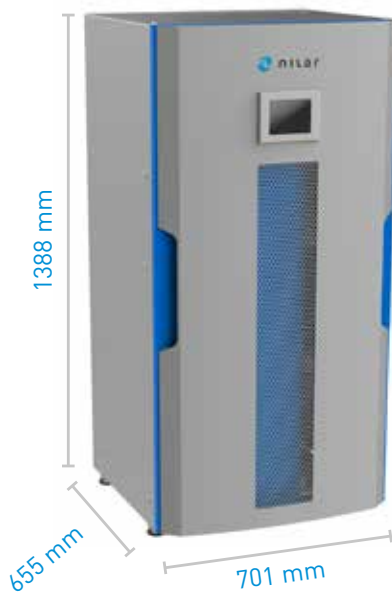

Figure 26.
 Cabinet 17,2 kWh

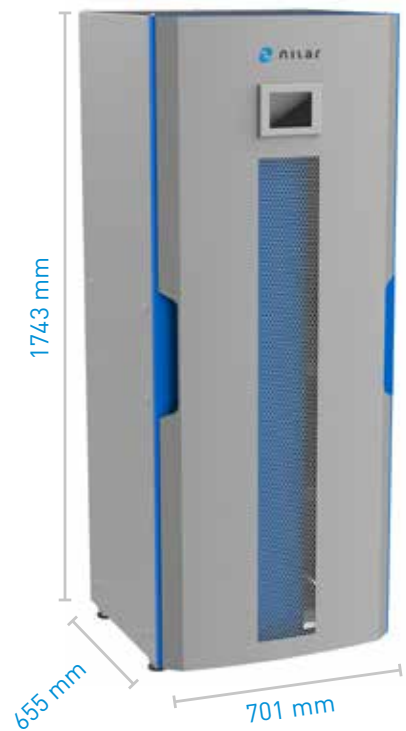

Figure 27.
 Cabinet 23 kWh



Visit our website at www.nilar.com
to find out who your local distributor is.

Nilar AB
Headquarters and Sales

Stockholmsvägen 116 B
SE-187 30 Täby
Sweden
Phone: +46 (0)8 768 00 00
Email: sales.europe@nilar.com

Nilar AB
R&D and Production

Bönnavägen 55
Box 8020
SE-800 08 Gävle
Sweden
Phone: +46 (0)26 960 90
Email: production@nilar.com

Nilar Inc.
R&D and Sales

10800 E. Bethany Drive, Suite 525
Aurora, CO 80014
USA
Phone: +1 720 446 0169
Email: sales.america@nilar.com