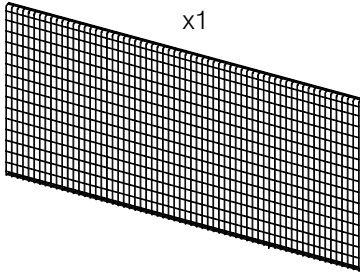
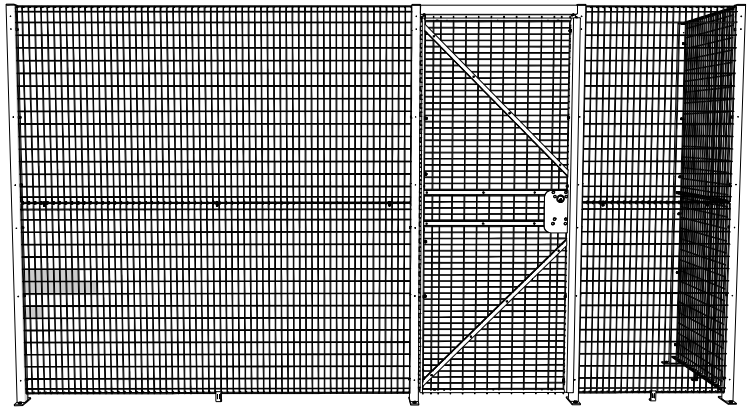
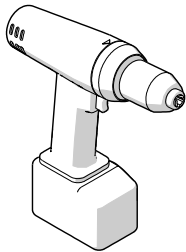
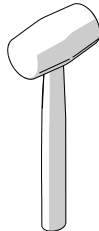
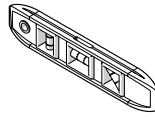

PARTS PROVIDED:

 WELDED WIRE PANEL
 (VARIOUS SIZES)

TOOLS REQUIRED:

ELECTRIC DRILL

 Ø 5/16" & Ø 3/8"
 MASONRY BIT

MALLET

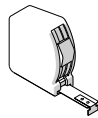
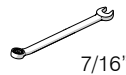
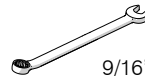

LEVEL

 MEASURING
 TAPE

 OPEN END
 WRENCH

WIRE CUTTERS

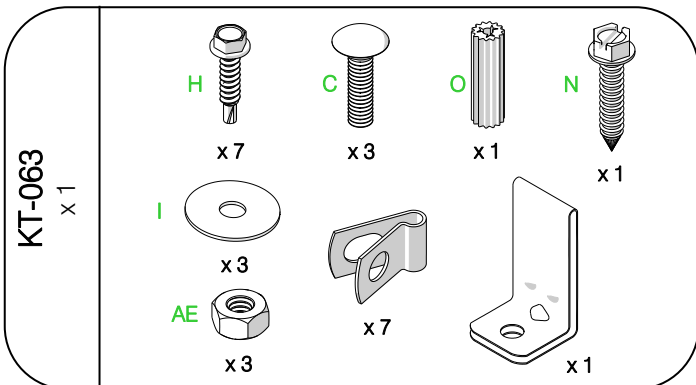

LADDER

HARDWARE PROVIDED:

HARDWARE LIST:

- (C) 1/4"-20 x 1" SQUARE NECK CARRIAGE BOLT
- (H) #12-14 x 1" HEX HEAD SELF-DRILLING SCREW
- (I) 1/4" FLAT WASHER
- (N) #14-10 x 1-1/4" SLOTTED HEX HEAD SMS
- (O) #14 x 1" TUBULAR PLASTIC ANCHOR
- (P) 3/8" x 3-3/4" WEDGE ANCHOR
- (AE) 1/4"-20 HEX NUT

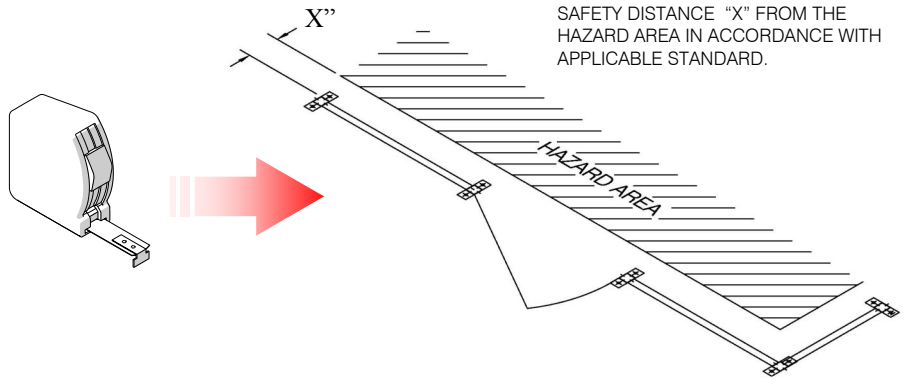
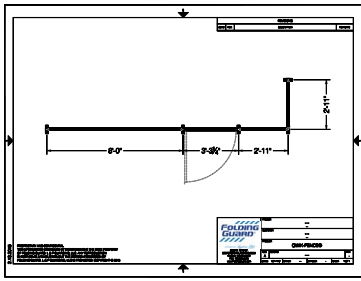
1

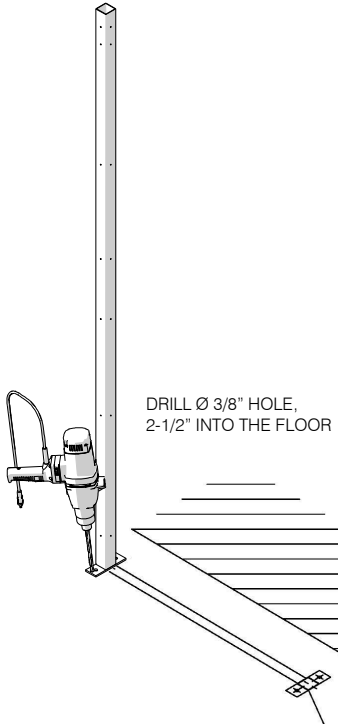

2



3

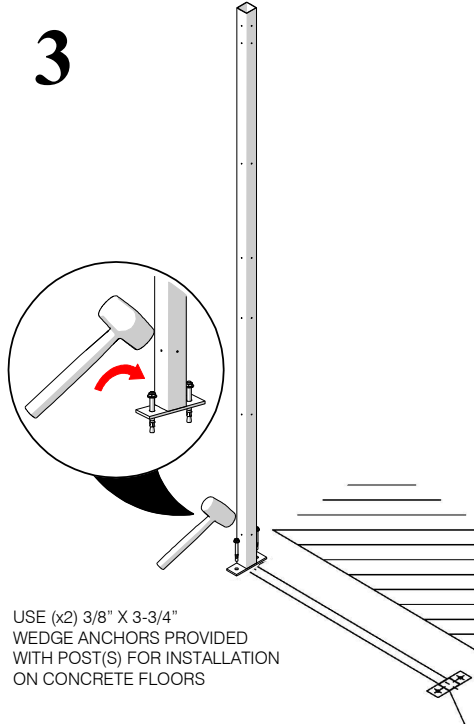

4

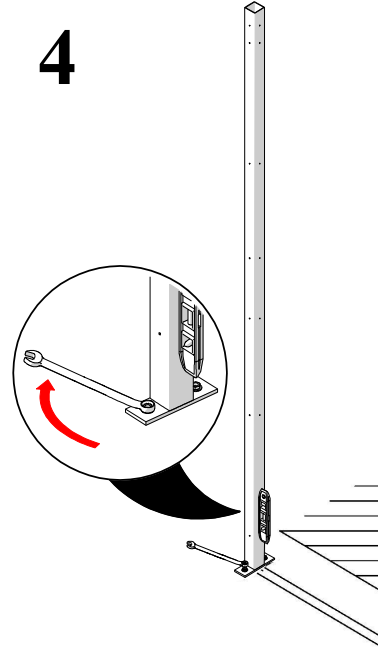

5

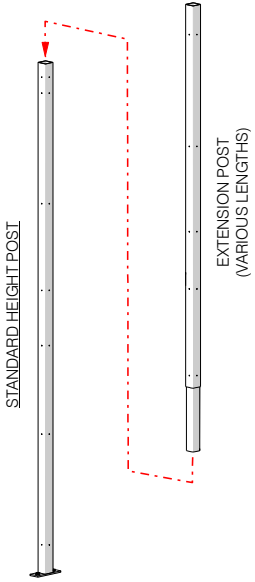

NOTE: STEP 5 IS FOR PARTITION TALLER THAN 8'-0" HIGH ONLY

6

