

Vectus – Intelligent Transport

Jörgen Gustafsson, M. Sc., M.B.A.
CTO Vectus Ltd.
jorgen.gustafsson@vectuspvt.com

Abstract

PRT, Personal Rapid Transit, is a transportation concept with small vehicles on a low weight structure, that combines many of the best aspects of today's urban public transport, and packages them together with unparalleled service and lower total cost of ownership. Vectus, with operations in Korea and Sweden, is at the forefront of PRT technology. Vectus has built a PRT test track in Sweden for validation of the system, and for obtaining safety approval. For the test-track, in-track linear motors are used powered by standard industry inverters combined with an in-house control concept. The system and its operational experiences are described.



What is PRT

PRT has been discussed as a concept for decades, and extensive research and various investigations have been made about its potential as a transportation system for tomorrow. Apart from a German effort in the 1970s, it was not until recently that more significant investments have been made with a view to actually developing a system that can be said to truly comply with the definition of “full” PRT. Vectus is one of the few companies that have built a full scale test track, and is able to supply a complete commercial system. Recently, in just the last few years, the interest and understanding of PRT as a public transport mode has been booming among city planners and transportation experts. What is PRT? The following characteristics define PRT and also the Vectus system.

Very small vehicles are used, at least they are considered small in mass transit terms. Typically they seat 4 – 6 passengers. The small size of the vehicles also gives a low weight, comparable to conventional automobiles.

The small vehicles run on a track with its own right of way. Very often PRT is envisaged to run as an elevated system, giving the advantages of flexible integration into cities without creating barriers and with minimal footprint in cities with scarce ground space.

The operation of the system can be compared to a conventional taxi operation. There are no timetables, and once you are en-route, you do not stop at any intermediate station. All stations, or stops, are offline, i.e. any vehicles having business at a stop to pick up or drop off passengers go onto a short sidetrack, and this keeps the main line free for other vehicles to pass without any restriction. After a trip is completed, and if there is no requirement for an empty vehicle elsewhere in the system, the vehicle will wait at the station, and hence save energy. This also provides excellent service for the next passenger arriving at the station, since the vehicle is already there waiting for the passenger. There will naturally be situations where empty vehicles will need to be moved in the system to match passenger flows, and part of the key to a successful PRT is in the optimization and logistics of the overall system.



Figure 1. First complete vehicle in full operation Summer, 2007.

For the system to be able to transport large numbers of people, a large number of vehicles are required. These will be capable of running quite close to each other, and the Vectus system has a headway of about 3 seconds between vehicles. With such a short headway, line capacities comparable to tram lines can be achieved.

With the stations located off-line, the vehicle will accelerate and then run at its operational speed all the way to its destination. This means that the average speed will be almost the same as the operational speed. Compared to city buses, trams and metro trains, which achieve average speeds in the range of 15-30 km/h, PRT can with a comparably low top speed of about 45 km/h give a shorter travel time compared to today's mass transit systems. Considering that, except for peak hours, there is no waiting time and overall travel time is significantly reduced.

The small vehicles, or more specifically the low weight of the vehicles, plus the distribution of the weight given by the distance between the vehicles, combined with the low speed, significantly reduces the

structural requirements on the infrastructure (the track) compared to e.g. trams or metro trains. This makes it possible to build a light elevated track at a fraction of the cost that is typical for conventional rail systems.

The switching mechanism for turning right or left in switches is located on the vehicle. It is the vehicle that steers itself rather than any moving parts in the track. To have on-board switching is a requirement to handle the short headways. Moving and securing a mechanical switch in timeframes of less than three seconds is simply not practical.

To fully understand the concept of PRT, one must understand the layout of the system. The system is typically configured with a number of interconnected one-way loops rather than the bi-directional corridors that characterize today's rail mass transit systems. In this way, with about the same amount of track, a system can cover a much larger area. Since station spacing does not impact journey time or the efficiency of the system, the stations can be located where they are best needed, and give tight mesh coverage when needed. With the loops, there will be some destinations where you will have to travel "around the block", but the additional time for this is negligible when considering the overall time savings compared to other modes of public transport.

The installation cost is lower than for conventional rail systems, and the operating cost is also kept low primarily due to the fact that the vehicles are driverless. This also enables the operation to run 24/7, around the clock, with very little additional cost, and most of the time, there will be vehicles waiting at the station when the passengers arrive, giving an unsurpassed level of service.

There are also several possibilities for using the same network for freight at off-peak hours. Variations of the vehicles to accommodate e.g. small containers, pallets etc. are easy to build, and give additional benefits in many applications.

Vectus Test Track

The Vectus decision to build a test track was made in 2005 after series of simulations of the top level control and logistics of larger systems along with various test set-ups of critical key components and solutions. The purpose has not only been to prove the technology, it was also a necessary way forward in order to establish the standards and requirements for transit authority approval, and to make a complete safety case including verification and validation. It is also an excellent showpiece for prospective clients as well as a good basis for further development and testing.

In May 2006 it was time for ground breaking in what was formerly a football field close to the university in Uppsala, Sweden. The track was built in UK and shipped by trucks and erected at the site in Sweden on the foundations. The track was swiftly prepared and the first test runs occurred in December, 2006 with a vehicle chassis. The vehicles were also manufactured in UK. However, the control system, the electrical system (propulsion) and most of the systems engineering work (safety, reliability, EMC etc.) was done in Sweden.

The test track is about 400m long. It is designed to make all critical tests for proving the required functionality of a commercial system. For the control system verification there is also an elaborate and comprehensive emulation environment. It has one outer loop, which is the main track, and one station track with a station. The whole outer loop is built at an angle, where the rightmost point is lowest and the leftmost point the highest point. In between there is a gradient of 1:50.

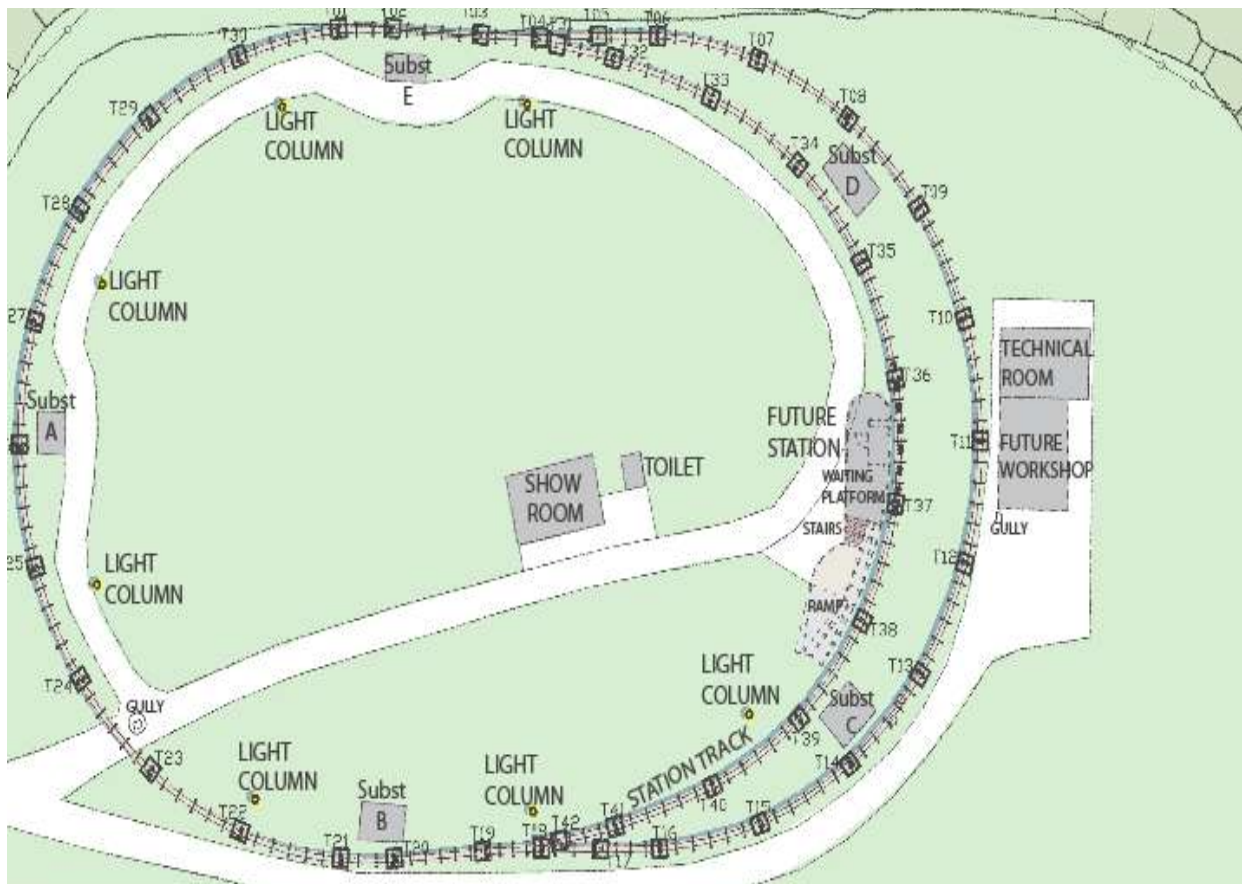

There are three vehicles. The vehicles have been designed to give a flavor of how a real system might look, whereas the track and other systems have been designed solely from the point of view of being efficient for testing purposes.

A complete safety case has been done for the Vectus system, and the test track. The control system has been given a third party assessment. The Vectus system has been approved by the Swedish Railway Authority, and meets the same safety levels for both passengers and third parties, the same as conventional railway, metro trains and trams in Europe. The test track is now being used for endurance testing as a way to prove the reliability and availability analysis.

In-track LIM (Linear Induction Motor) rationale

For a system with high numbers of vehicles in relation to the length of the track, the reliability of the vehicles is of outmost importance. In order to run with short headway, including very tight margins between nominal operating point and the “speed – free distance” safety-brake application curve, precise and consistent performance of the drive system is a vital component.

Linear motor drives have often been the choice in other PRT concepts. This is also the case in the Vectus system. Vectus has built its own control system to be able to handle all types of propulsion solutions, but for the test track built during 2006, and operated since then, the choice fell to an in-track LIM propulsion solution.

The main reasons for this were:

- The system should be capable of handling snow and ice conditions without any performance degradation. Linear motors give the same thrust regardless of the available friction between wheel and rail, both in motoring as well as in braking.

- To give maximum reliability and safety, the problems often related to the power transfer to the vehicles were eliminated by not needing an electrical current collection system. This also is a safety improvement, further reducing any risk for electrocution by having all electrical installations safe to touch by means of conventional cables.
- The vehicles could be made simpler, and overall maintenance requirements were minimized.
- Noise is an important consideration in any urban installation. Compared to a typical conventional tire drive with motors and gearboxes, it is quieter.
- Higher availability by offering less dependency on individual propulsion components.
- Local requirements for higher thrust can be handled in the track by e.g. higher thrust LIM, or positioning same thrust LIMs closer to each other. With this, the vehicles need not be dimensioned for the worst case thrust situation along the track, but rather the track can be built and locally adapted to give local performance as required.
- Easier track design and installation are possible with easily adjustable motors rather than the complexity of having a reaction plate in the track.

The linear motor has been specially designed and built for Vectus' PRT requirements by Force Engineering in England. The inverters are standard industrial inverters supplied by Parker Hannifin in Sweden (previously SSD). The control and associated electronics, software, etc. has been developed in close collaboration with Noventus, Sweden.



Figure 3. The test track with “double density” linear motors in the acceleration ramp out from the station in Swedish winter weather. The blue building contains the electrical equipment and the propulsion inverters, and cables are routed from the building to each LIM. In a commercial application this will all be integrated into the track using custom- built, small size inverters fully utilizing the short duty cycle for each LIM.

The supply of on-board power for control electronics and air conditioning is not obvious with in-track LIM. At the test track there is a combination of on-board batteries being charged whenever the vehicle is idle at station stops combined with an alternator being driven off one of the vehicle wheels to provide

power while running. If the on-board power requirements become extreme, this may not be adequate. Hence, Vectus for their PRT system has designed the control and safety systems so any drive technology using current collection can be easily implemented if required.

Propulsion system description

The electrical system is shown in figure 4. It has been built with the requirement that any single fault will not cause more than every second LIM to be inoperative, and then only for a limited part of the track. As the PRT system almost always has the vehicle running at close to top speed, any individual LIM not working will not be a stopping fault. It will in fact hardly be noticed at all, the vehicle will just coast past the failed unit, into the next LIM.

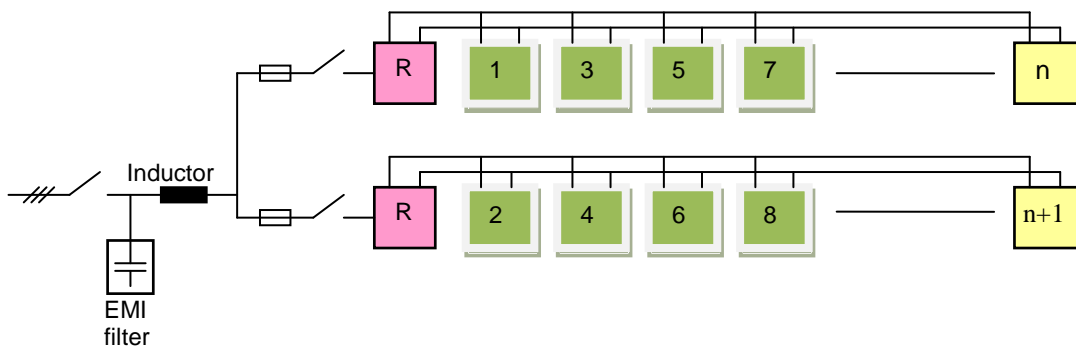

Figure 4. The incoming 3-phase AC supply first passes standard switchgear and filters. It then supplies two banks of inverters (green). Each bank has a common rectifier (pink) supplying the inverters via an internal DC bus. The number of inverters in each bank is a trade-off with the cabling to the actual linear motor. For a commercial system a different concept would be deployed. For the test track there are a maximum of 9 inverters for each bank. The number inside the green inverter boxes indicate the linear motor number (LIM are supplied from alternating banks, so that two in a row will not be affected by typical single point failures).

The general concept is to have a number of inverters connected to one rectifier unit. The inverters then drive every second LIM, so a failed rectifier (DC supply), or depending on the power-supply design, even an AC power-supply failure, will still not give consecutive LIM failure.

The test track vehicles have a 3.5-meter-long reaction plate along the centre line of the vehicles. This in turn has given a spacing of the LIMs of 3.5 meters, so there is always the same total coverage of reaction plate and LIM. In several areas of the track the LIMs are located closer due to geometrical constraints e.g. in switches etc. In the acceleration zone after the station, there are twice as many LIMs (spacing of 1.75 m) in order to give the required thrust so that the acceleration required to get the vehicle up to operating speed before entering the switch is achieved.

At a nominal speed of 12.5 m/s, each LIM (with an active length of 1m) is passed by some part of the reaction plate for a vehicle moving distance of 4.5 m. For a vehicle movement of 2.5 m, the LIM is fully covered by the reaction plate. The other 2 m has only partial coverage of the reaction plate. The inverter is switched on just before the vehicle front approaches the LIM, and is switched off again when the

vehicle has passed. Duration of this is about 1/3 of a second, and then the LIM and associated inverter is idle until next vehicle comes, which in a minimum headway situation would be approximately 3 seconds later. This gives a duty cycle of about 1 in 8 to 1 in 10. The inverters utilized for the test track are standard industrial VVVF inverters controlled via a CAN bus (Controller Area Network) interface from a Vectus-developed motor controller. Voltage and frequency is varied throughout the whole passage of each LIM to give the vehicle exactly the right speed regardless of running resistance or other loads, or overlap between LIMs etc.

One of the challenges in any linear motor application is to have a small air gap between the motor and the reaction plate. With the motors in-track, the problem to maintain a small air gap is of a different nature since the length of the reaction plate is much longer than the length of a motor. This obviously puts restrictions on how small the air gap can be in vertical curves, and it is inevitable that the air gap will vary as the vehicle passes a motor, due to the track being convex or concave compared to the straight reaction plate.

Furthermore, when going through a transition curve there is a track twist, which with a completely stiff chassis (reaction plate) would mean that one wheel loses contact with the track. To solve this, the vehicle reaction plate is made in two separate halves that can rotate in relationship to each other. Because of this, each reaction plate half is kept level between the front or rear pair of wheels. Therefore the actual length of the reaction plate which is subject to a certain track twist is only half of the total length, which enables an overall smaller gap between linear induction motor and the reaction plate. This arrangement also prevents the wheel from unloading in track twist conditions. The short interruption of the reaction plate does not give any noticeable impact on the thrust, but is at lower speeds clearly distinguishable in the LIM current wave shape.

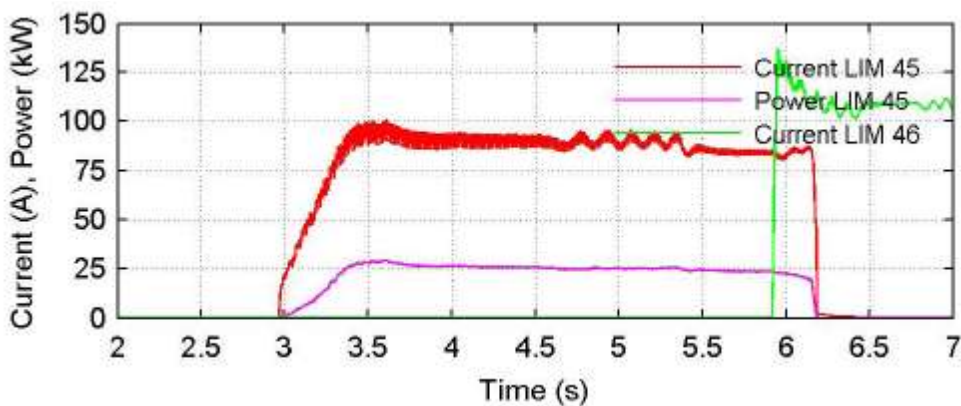

Figure 5. Current to a linear motor when accelerating from very low speed. Oscillation occurs when reaction plate discontinuity passes across the motor.

Control system description

The control loop for the system is split between the vehicle and the track-mounted equipment. The control feedback loop starts on the vehicle, where position and speed is determined. This information is sent to the wayside motor controller, which determines which inverter shall be active (two or more are active at the same time when the reaction plate overlaps several LIMs). Based on the reference speed and the actual speed of the vehicle, the thrust is controlled by varying voltage and frequency. The timing

for switching on and off each inverter (so that there is power on a LIM only when there is a reaction plate at least partially covering it) is also handled by the motor controller based on the vehicle's own positioning information. This means that there are no active components in the track, except for the motors that are very rugged and are encased in stainless steel enclosures. The data transfer and accuracy of the information makes it possible to control the speed very accurately even at quite low speeds (down to less than 0.5 m/s).

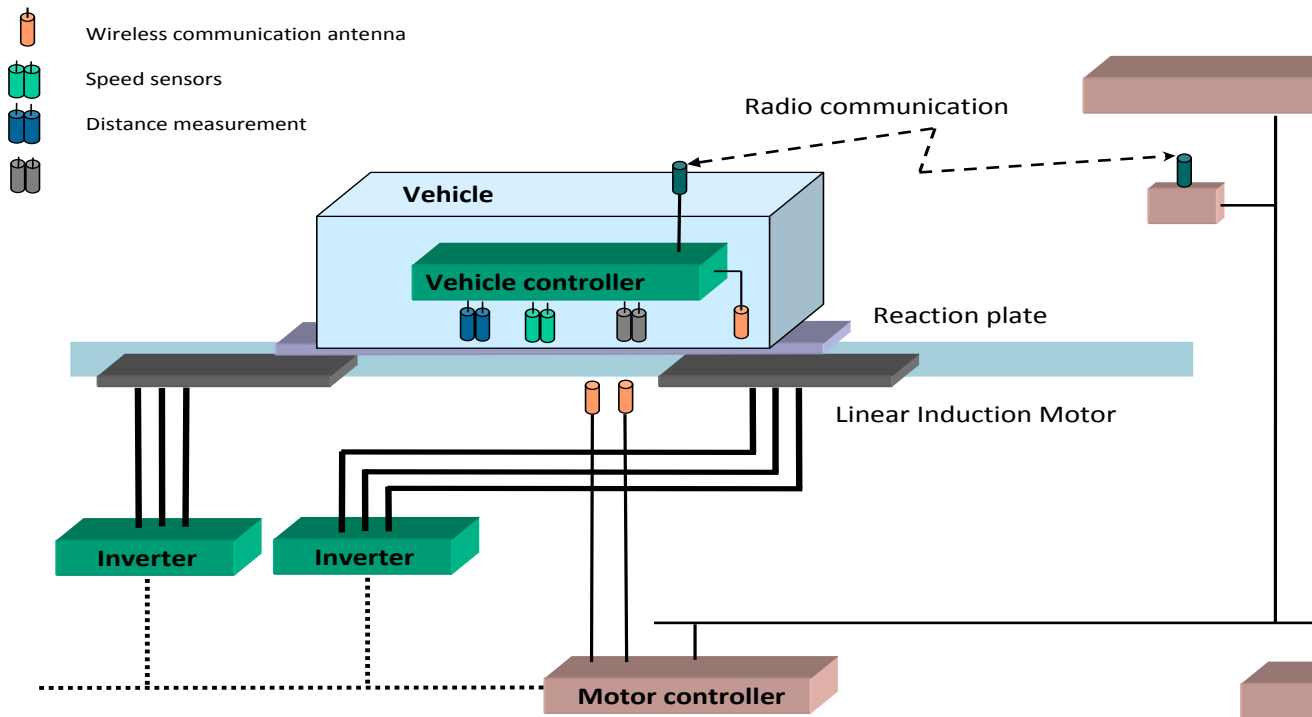

Figure 6. Separate, redundant speed sensors and encoders for distance measurement are located on each vehicle. The information is processed on-board the vehicle, and data is forwarded via redundant radio links to the track-side system. The track system consists of motor controllers that does the actual control loop processing, and via a CAN bus interface communicates to a series of inverters, giving commands for voltage and frequency.

The motor control required is best illustrated by the example in figure 7. The plot (figure 7) shows a fairly light vehicle running around the track with constant power and frequency supplied to all the LIMs. As can be seen, the speed varies significantly as the vehicle goes around the track. The larger sinusoidal shape is due to the fact that the track is an oval shape put on an incline, i.e. speed decreases when going uphill, and increases when going downhill. The smaller variations are due to the fact that the LIMs are spaced with the actual length of the reaction plate. As expected and calculated, when the reaction plate is halfway over two LIMs, the total thrust is slightly higher compared to when the reaction plate fully covers only one LIM. This effect is more pronounced the lower the speed is. With the control engaged, and the frequency and voltage is controlled, based on the speed feedback from the vehicles, a speed curve for running around the same loop is basically a straight horizontal line. The accuracy of the speed is in the range of 0.05 m/s, based on time discrete radio feedback, with the possibility of transmission delays, etc.

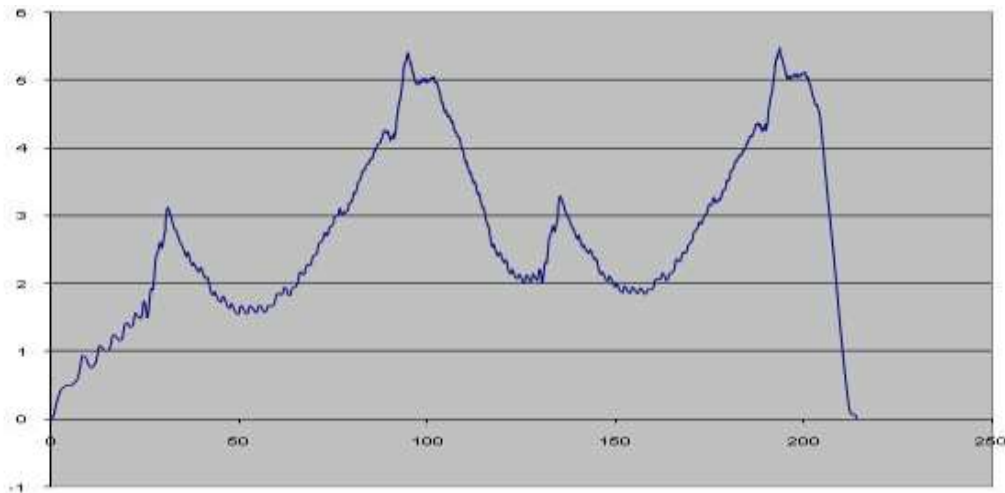

Figure 7. The blue line above shows the speed under inverter static control (a constant voltage and constant frequency). The horizontal axis is time (seconds). At time of 90 and 190 seconds the vehicle is going downhill and picking up speed due to gravity. The peaks at time 3, 90, 140 and 190 are at the switches where there are several linear motors at closer distance than the typical 3.5 giving an increased thrust. This is due to the geometrical constraints of where to locate the linear motors in the switch.

The vehicle positioning is also very accurate, to within a few centimeters. The timing for switching on and off is very important for overall energy consumption. If switching on is done too early, the inverter will supply a motor with the equivalent of a missing rotor, and the current will quickly go to the limitation of the inverter, with a high phase angle.

Some sample curve shapes are shown in figure 8 showing the electrical current when passing a LIM. The current is high when entering and leaving, as the reaction plate coverage is low. The best energy efficiency would be to only have the LIM on when fully covered, but that is not practical as there is not enough time to ramp the inverter up and down, and without a ramp, the sudden energizing of the LIM causes both a sudden attraction force, and also of course, a longitudinal oscillation since power would not be on all the time to give a smooth, continuous thrust.

In figure 8 three adjacent LIMs' current is shown. At some short distance before the middle LIM a sensor was located which indicates when the reaction plate is above the sensor. This is represented by the black line in the figure. As can be seen, the center LIM (red) is switched on approximately when the reaction plate is at the sensor (about 10-15 cm before the LIM), and as the coverage of the LIM reaches the full length of the LIM, the current is reduced, and then increases again as the "stator" coverage again decreases. When the reaction plate leaves the sensor, the LIM still has to be switched on until the length of the reaction plate also has passed the plate.

Not shown in the picture, but as can be understood, the phase angle shifts significantly during the passage, and the high current is not a substantial load to the supply network. It is mostly a circulating current.

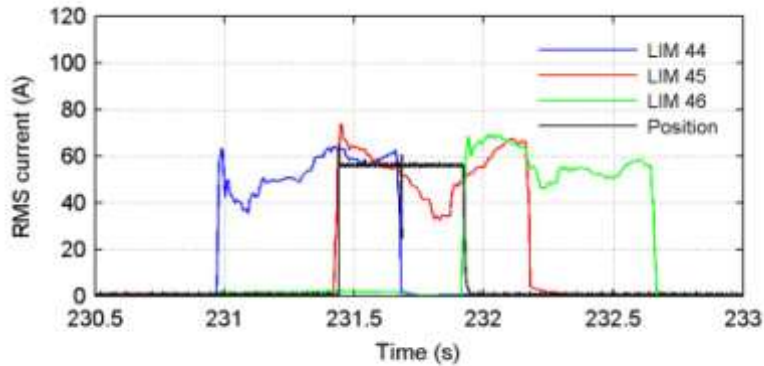

Figure 8 : Blue, red and green are the currents for three consecutive linear motors. The black line is an indication of reaction plate passage at one point in the track some distance ahead of the red linear motor. The RMS current for each motor are affected by the coverage of the reaction plate, and also of course by the control itself in maintaining constant vehicle speed.

It is for lower installation costs, and also for reliability and performance, advantageous to have a system where there are no active devices in the track to determine speed or position, and yet the control is done from the track. To further exemplify the level of control actually done, the chart in figure 9 shows the voltage demand for running at constant speed around the track, which as can be seen, is rapidly and frequently adjusted to maintain accurate speed. This control also works well at very low speeds, without any vibrations or other side effects at any speed.

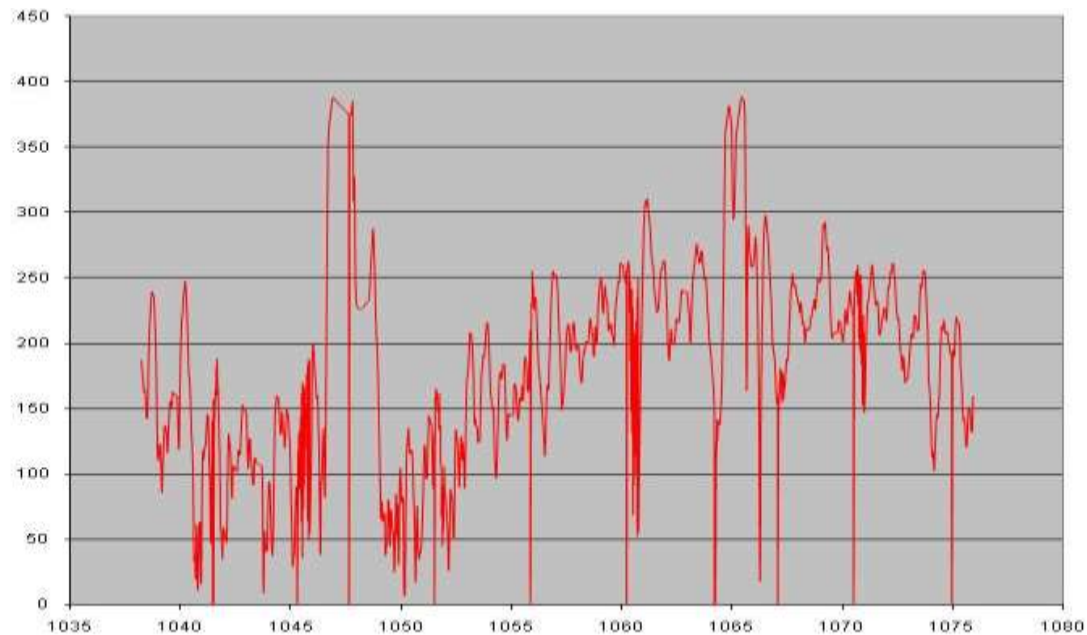

Figure 9: The red curve indicates the voltage (as a function of time in seconds) ordered by the motor controller going through a lap on the outer loop at constant speed. Same sinusoidal shape as given by the varying gravitational load on the vehicle going around a loop track tilted at an angle (also seen in the speed at constant power above) is clearly seen.

Figure 10 shows the dynamic performance. A speed reference of 4 is given initially, and full voltage is demanded to bring the vehicle up to the desired speed. It then controls the speed at 4 until a new reference of 8 is given after about 16 seconds. After about 28 seconds a speed reference of zero is given, and dynamic (electrical) braking brings the vehicle to a complete stop.

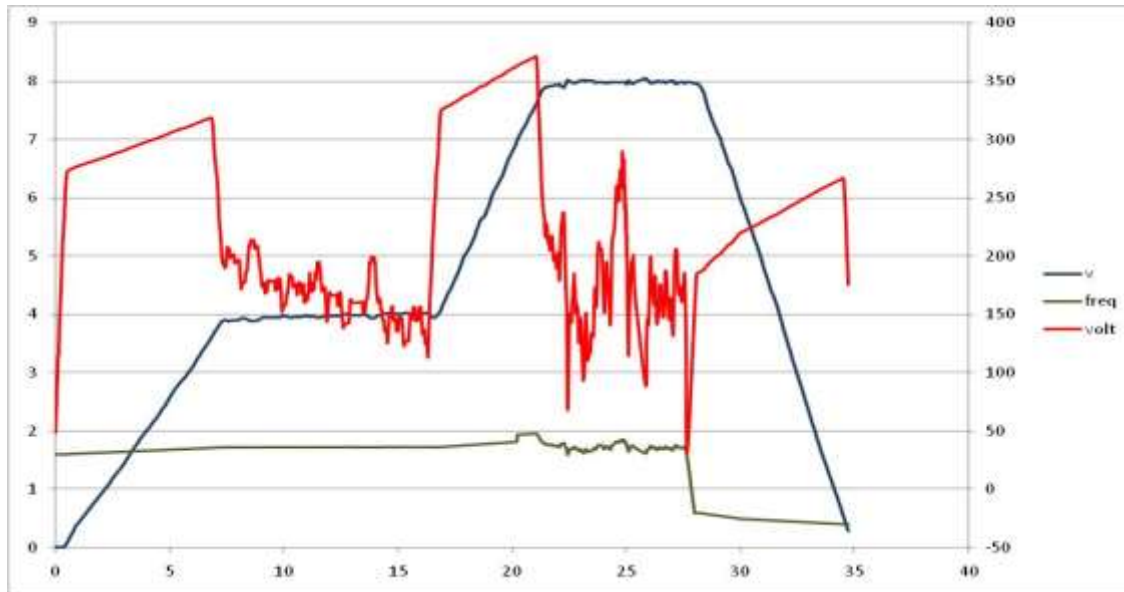

Figure 10: The red curve indicates the voltage (as a function of time in seconds) ordered by the motor controller (volts per right hand vertical scale). The dark blue line is the vehicle speed (m/s, left vertical axis). The green line indicates the frequency (Hz, right hand vertical scale).

Operational experience

One of the key challenges with PRT is to run vehicles with a short headway, and even more so, to be able to merge vehicles in a switch maintaining a short headway. With three vehicles on the test track this has been successfully demonstrated. The safety case has been completed, and the required authority approvals have been obtained to also carry passengers.

The reliability and availability targets for the system have been set very high. There has been a complete RAM (Reliability, Availability and Maintainability) analysis carried out, and the propulsion system has a very low share of any potential stops or delays. So far, with about 2 years of trial operation, there has been only one faulty component, a communication board for a CAN bus (Controller Area Network), automatically diagnosed and repaired in a matter of minutes. The fault had no real impact on operation of the track, and would have caused neither a stop nor a delay in a commercial application, confirming the RAM analysis.

Extensive testing has been carried out, and the calculated performance of the propulsion system has been accurate with the measurements. Maintaining air gap has not been an issue at all and there has not been any need for readjustment or corrections of the LIM height settings in the track. Operation in winter conditions has been flawless as well.

The next steps are to run the system and accumulate more mileage for experience feedback and further proving of the RAM models.



Conclusions

The test track has shown that the Vectus concept for Personal Rapid Transit fulfils all the required operating characteristics. This involves various attributes including safety, reliability and performance of the vehicles. The Vectus test track has clearly shown that it is possible to achieve this in a very attractive way using in-track linear motors. It is smooth, very quiet and reliable. The Vectus control has also been proven to work very well. It works without any active components in the track to detect vehicle position or speed. This is especially favorable in harsh conditions, in particular, with snow and ice conditions, and boosts the reliability of the system even further.

