

## INSTALLATION AND SERVICING INSTRUCTIONS FOR THE STRAXGAS THEME PLUS WITH 16" ECOTECH BURNER

(To be left with the appliance)

### Appliance data:

Type of gas	: Natural gas (G20) Cat. I2H	Propane gas (G31) Cat. I3P
Injector size	: 7 x 0.80 multihole	7 x 0.53 multihole
Injector marking	: 80	53
Gross heat input (high setting)	: 6.9kW (23,500Btu/h)	6.9kW (23,500Btu/h)
Gross heat input (low setting)	: 4.4kW (15,000Btu/h)	3.5kW (12,000Btu/h)
Supply pressure	: 20mbar (8in.w.g.)	37mbar (14.8in.w.g.)
Appliance test point pressure (cold)	: 19.0mbar ( $\pm$ 1.0mbar)	36.5mbar
Type of flue	: Class 1 (7in. dia.), Class 2 (5in. dia.) or precast block flue	
Minimum effective height of chimney	: 3m (10ft.)	3m (10ft.)
Ignition	: Piezo	Piezo
Spark gap	: 3.0mm min., 4.5mm max.	3.0mm min., 4.5mm max.
Dimensions:		
Width over frame excluding trims	: 473mm	
Height including frame	: 585mm (534mm Lowline Version)	
Depth	: 180mm	
Shipping weight	: 36kg	
Country of destination	: United Kingdom and The Republic of Ireland	

**NOTE: The Natural Gas and Propane Gas versions of this appliance are different models and cannot be converted from one gas to another.**

This appliance has been assessed by a Government appointed Notified Body and shown to meet the 'Essential Requirements' of the European Gas Appliance Directive.

The Directive lays down requirements for the safety of the appliance, together with its design, construction, and use of materials. It also requires the production process to be covered by an approved and monitored system of quality assurance.

## Mandatory requirements

Straxgas fires must be installed with due regard to the following mandatory regulations:

The relevant British Standard installation specifications and codes of practice, and Building Regulations issued by the Department of the Environment, and Building Standards (Scotland) Consolidated Regulations issued by the Scottish Development Board.

Gas Safety (Installation and Use) Regulations.

Failure to install this appliance correctly could lead to prosecution and render the guarantee invalid.

Attention is drawn to the latest edition of the following standards:

BS1251, Specifications of open-fireplace components.

BS5440, Part 1, Specification for installation of flues.

BS5440, Part 2, Specification for installation of ventilation for gas appliances.

BS5482, Part 2, LPG, installations in permanent dwellings.

BS5871, Part 2, Installation of decorative fuel effect gas appliances.

BS6891, Specification of low pressure gas pipework

BS8303, Replacing CP403.

This Straxgas appliance is an inset live fuel effect gas fire and must only be installed by a competent person (e.g. a C.O.R.G.I. member) in accordance with these installation instructions. This appliance must be installed in accordance with the rules in force, and used only in a sufficiently ventilated space. Consult these instructions before installation and use of this appliance.

**GB** Additional purpose made air ventilation is not normally required.

**IE & Northern Ireland** Ventilation must be provided in accordance with the rules in force.

---

## Preparation

### Before installation

Ensure that the local distribution conditions (identification of the type of gas and pressure) and the adjustment of the appliance are compatible. Refer to burner data badge plate.

### All types of flue

Ensure that:

- It only serves one fireplace
- Any terminal or cowl fitted is approved for use with this type of appliance.
- It is clear of any obstruction and any damper or restrictor is removed or fixed permanently in the fully open position.
- Any chimney used for an appliance burning a fuel other than gas must be thoroughly swept before installing any gas appliances.
- With an L.P.G. (propane) fire, any air supply entering the fireplace below floor level is completely sealed off.
- The chimney is properly sealed so that the combustion products do not come into contact with combustible materials outside the chimney.
- The base of the chimney is clear of loose debris, bricking up, etc.

Check with a smoke match that there is a positive updraught present. If a terminal is fitted check that it is free from obstruction and does not restrict the exit and safe dispersal of combustion products.

### Location

This appliance is not suitable for installation in a room containing a bath or shower.

The THEME PLUS may be installed to any of the following:

- A masonry chimney with a minimum cross sectional area of 24,000 sq.mm, lined flue with a minimum dimension of 100mm or a minimum diameter of 175mm and a minimum effective height of 3m and having a throat forming lintel conforming to BS1251. The appliance may be installed either: (a) without removing the chairbrick **but the spacer frame MUST be used**, (see Fig. 2a for minimum depth requirements), or (b) in a builder's opening with sufficient volume for debris collection conforming to Fig. 2b.
- A pre-cast block flue conforming to the requirements of BS1289 with a minimum cross sectional area of 16,500 sq.mm and a minimum dimension of 90mm. The appliance may be used with the spacing frame described above if it desired to fit a shallow mantel. See Figs 2c and 2d for minimum depth requirements. *Ensure that mortar fangs between the blocks do not protrude into the flueway. It is essential that the flue terminal does not restrict the flue flow and complies with BS1289; if not, replace with an approved terminal.*
- An insulated twin walled metal fluebox and flue system with a minimum diameter of 125mm, and minimum effective height of 3m. The system must conform to the constructional requirements of BS715 and Fig. 4.

The different types of installation are fully described in the next section.

The appliance must only be installed into an opening against a non-combustible wall.

### Clearances

If a shelf is to be fitted above the fire, perhaps as part of a surround, it must be positioned a minimum of 1m (39in.) above the top of the hearth, and project no more than 200mm (8in.) from the front plane of the opening. Combustible material such as wood may be fitted to within 100mm (4in.) of either side of the opening so long as it projects no more than 100mm (4in.) from the front plane of the opening.

Soft furnishings, decorations and some wall coverings may discolour or scorch if positioned too close to the fire

## Installing the fire

### Site preparation

The Straxgas Theme Plus must be installed on a level, non-combustible hearth in accordance with BS5871, Part 2. See also approved document J 1/2/3 "Heat Producing Appliances" issued by the Department of the Environment.

Clear the working area of all debris before removing the Straxgas appliance from the packaging.

### Items supplied

The following items will be found within the carton:

1. Convection box.
2. Separate flat trim, optional canopy trim, or spacer frame with box trim depending on options ordered.
3. Burner complete with controls
4. Restrictor plate, (use depends on type of installation).
5. Optional fret.
6. 1 back, 1 centre, & 2 front ceramic sections.
7. Coals (6 large, 4 small)
8. Foam sealing strip
9. Screws and wall plugs to complete the installation.
10. These installation instructions, guarantee card and end user operating instructions.

**Warning:** Only Straxgas approved ceramic blocks and coals, designed for this appliance, must be used with this burner. Use of ceramic components from any other supplier will invalidate the guarantee and may be dangerous.

When unpacking the appliance, avoid touching the visible, painted parts as the paint requires curing (this will take approximately 2 hours under fire. In some cases there may be a slight odour given off for a short period).

### Fret options

The following Straxgas frets are suitable for use with this appliance:

- Black finger (brass or stainless finials & ash pan ring)
- Brass finger
- Stainless finger (polished or satin)
- Classic, Silver Classic
- Gainsborough (all brass or black)
- Delta (polished or satin)

If a fret from another manufacturer is being used, it must comply with the minimum free area requirements shown in Fig. 1.

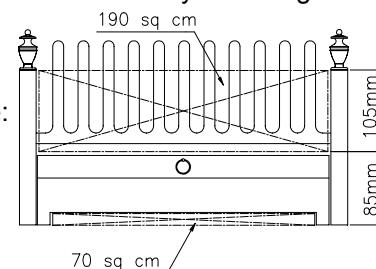

Fig. 1 Optional fret min. ventilation requirement

### Gas connection

Note: Gas connection shall be with rigid or semi-rigid pipe, by concealed connection only. A 15mm (10mm for propane) gas supply pipe with isolation cock should be brought to within 1M of the fireplace opening. The connection to the burner can be made from the right or left-hand side by a concealed pipe from behind the burner to the elbow on the left-hand side of the burner. Use a pre-punched hole in the convection box to allow the gas supply pipe to be installed. 8mm pipe is required for this purpose.

*When passing the pipe through brickwork or plaster, cap the end to prevent entry of debris.*

**WARNING: Always blow pipework through before connecting to appliance - contamination will permanently damage the burner.**

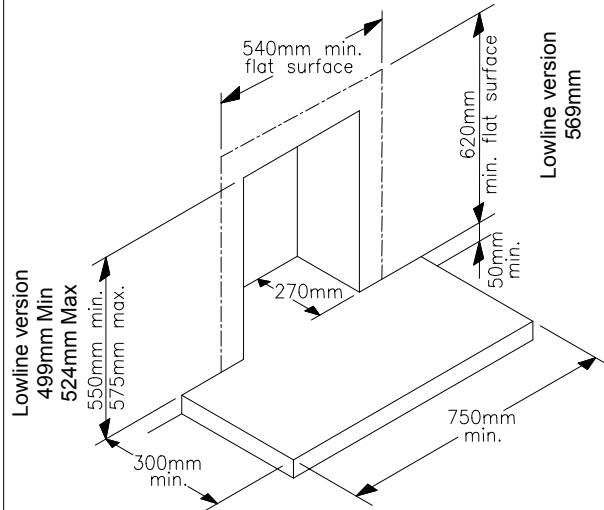
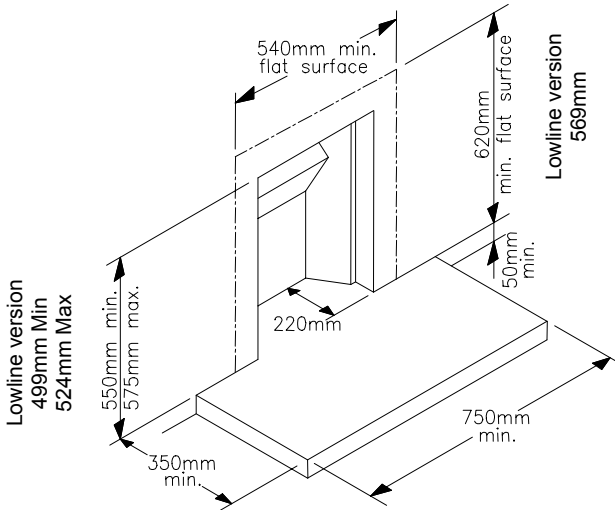
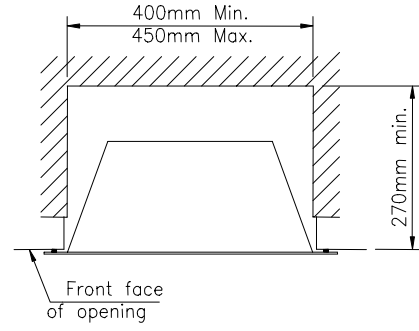
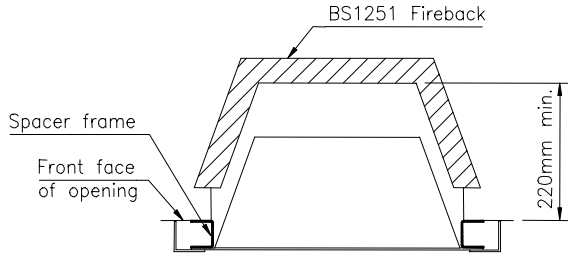

Fig.2a Masonry chimney with chairbrick

Fig.2b Masonry chimney without chairbrick

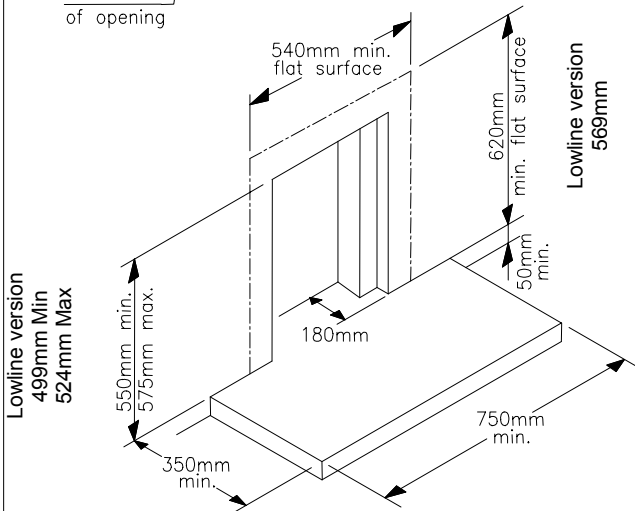
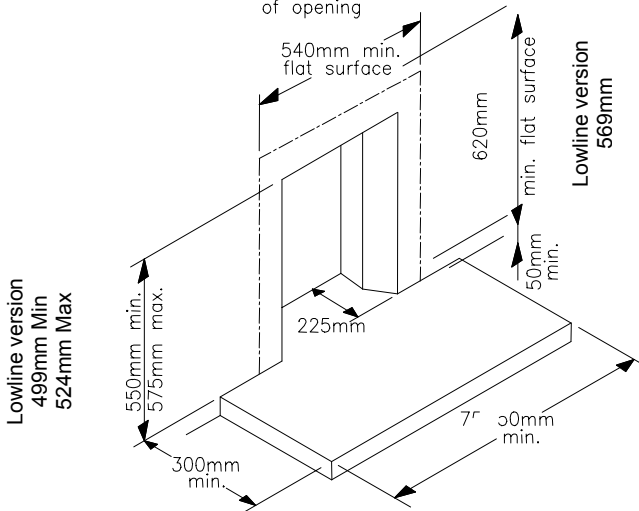
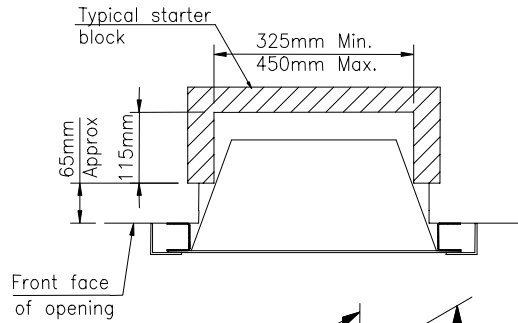
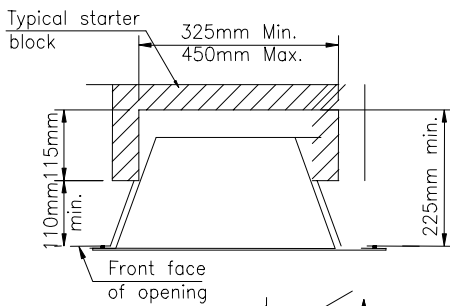

Fig.2c Pre-cast block flue

Fig.2d Pre-cast block flue used with spacing frame

## Assembly sequence

### Masonry chimney

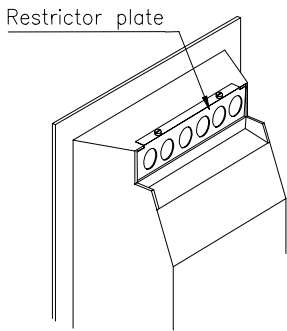

Fig.3 Fitting the restrictor plate

#### With chairbrick (Fig. 2a)

1. Attach the spacer frame to the back of the convection box flange using the four countersunk screws and nuts provided.
2. Fit the restrictor plate with its bottom edge inside the flue outlet, using 2 screws provided, as shown in Fig. 3.
3. Secure the self-adhesive foam sealing strip to the back of the spacer frame (Fig. 3a).
4. Slide the firebox into position, making sure that the sealing strip is compressed and forms an effective seal around the complete frame.
5. Drill the front face of the opening to match the 4 holes in the spacer frame and insert the plugs provided.
6. Secure the convection box using the screws provided or alternatively use optional wire fixing kit.

#### Without chairbrick (Fig. 2b)

1. Secure the self-adhesive foam sealing strip to the back of the convection box flange (Fig. 3a)
2. Fit the restrictor plate with its bottom edge inside the flue outlet, using 2 screws provided, as shown in Fig. 3.
3. Slide the convection box into position, making sure that the sealing strip is compressed and forms an effective seal around the complete frame.
4. Drill the front face of the opening to match the four holes in the flange of the appliance and insert the plugs provided.
5. Secure the convection box using the screws provided or alternatively use optional wire fixing kit.

### Pre-cast block flue (Figs. 2c and 2d)

**Note:** The outlet restrictor plate must not be used with this installation.

1. If the spacer frame is being used, attach it to the back of the convection box flange using the four countersunk screws and nuts provided.
2. Secure the self-adhesive foam sealing strip to the back of the spacing frame or convection box flange as appropriate (Fig. 3a).
3. Slide the convection box into position, making sure that the sealing strip is compressed and forms an effective seal around the complete frame.
4. Drill the front face of the opening to match the four holes in the flange of the appliance and insert the plugs provided.
5. Secure the convection box using the screws provided or alternatively use optional wire fixing kit.

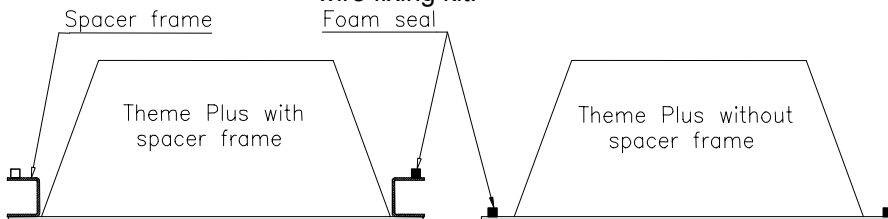
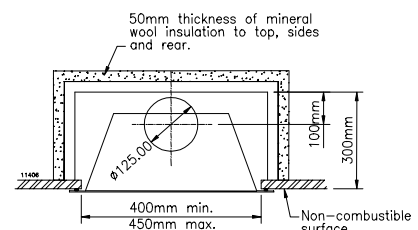

Fig.3a Attaching foam seal



### Wire Fixing Kit (Optional)

The kit supplied enables the convection box to be secured to the opening without drilling any holes in the surround.

Items supplied:

1. 2 wire ropes with fixed nipple
2. 2 Sleeve bolts and backnuts
3. 2 Adjustable nipples with clamp screws
4. 4 Screweyes and wall plugs

1. Mark out and drill 4 holes in the back of the opening to suit wall plugs supplied. See the drawing for dimensions. Insert the screweyes and align to allow the wires to pass through vertically.

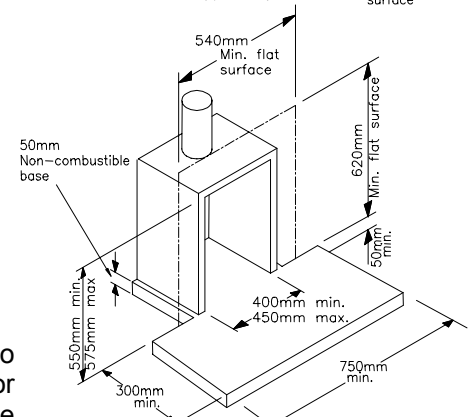
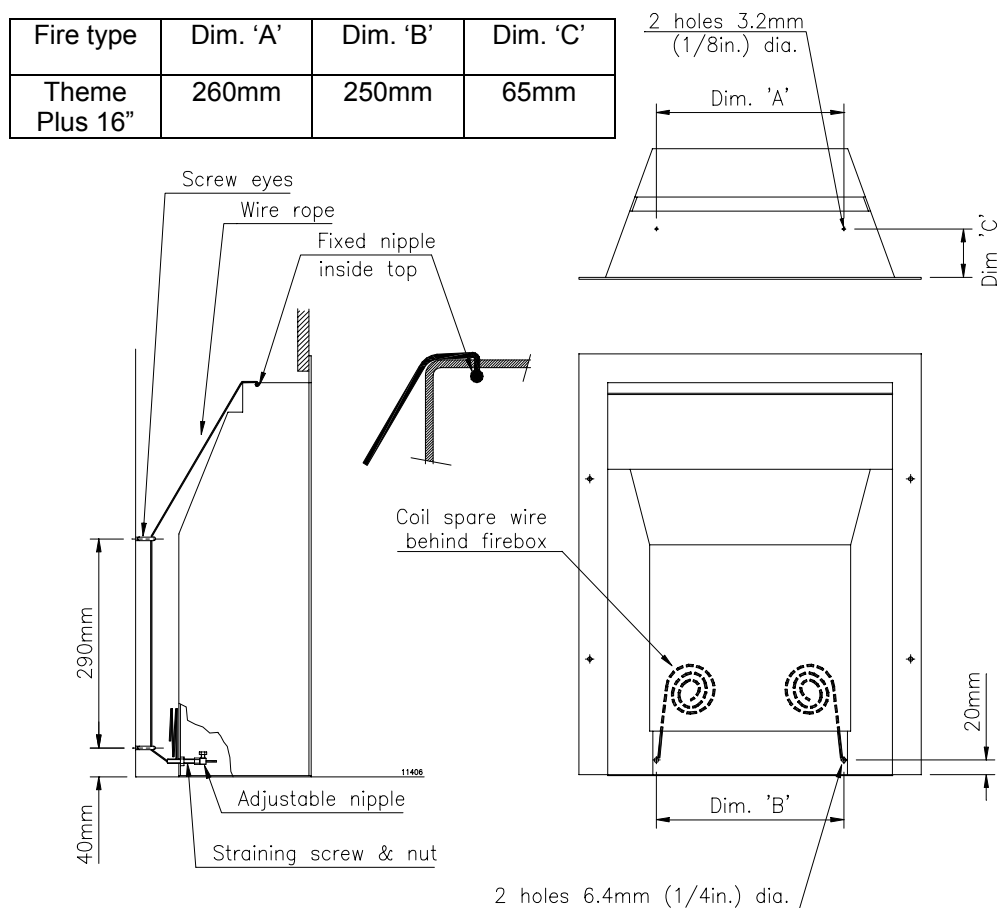

Fig.4 Metal fluebox and flue system

2. If the convector box has not been pre-punched for the wire ropes, drill the top and back shown in the drawing, removing burrs from the drilled holes.
3. Pass one wire rope through each top hole, from the inside out, and pull through until the fixed nipple rests against the inside of the top plate.
4. Place the convector box near the opening and pass each wire rope through the top and bottom screweyes, and back through the holes in the back of the convector box.
5. Push the convector box into the opening up to the surround, pulling the wire ropes through to take up all slack.
6. Run the backnuts up to the heads of the sleeve bolts, and thread a sleeve bolt over each wire rope, threaded end first.
7. Push the sleeve bolts into the holes in the back of the convector box as far as the backnuts.
8. Thread an adjustable nipple on to each wire rope up to the heads of the sleeve bolts. Pull any slack wire through the nipple and tighten the clamp screws.
9. Make sure that the foam seal behind the fire flange is compressed all round and then, using two spanners, screw the backnuts down the sleeve bolts in order to tension the wire ropes and hold the convector box against the surround.
10. Coil up surplus wire rope and store inside convection channel (see drawing). **Do not cut off surplus**; possible future removal and refitting of convector box requires the full length of wire supplied.



#### Metal fluebox and flue system (Fig. 4)

**Note:** The outlet restrictor plate must not be used with this installation.

1. The metal fluebox must stand on a non-combustible hearth of at least 50mm thickness.
2. The top, sides and rear of the box must be covered with a 50mm minimum thickness of mineral wool insulation.
3. Secure the self-adhesive foam sealing strip to the back of the convection box flange.
4. Slide the convection box into position, making sure that the sealing strip is compressed and forms an effective seal around the complete frame.
5. Drill the front face of the opening to match the 4 holes in the flange of the appliance and insert the plugs provided.
6. Secure the convection box using the screws provided.

## Final assembly for all types of flue

Following satisfactory installation of the convection box into the opening, proceed as follows:

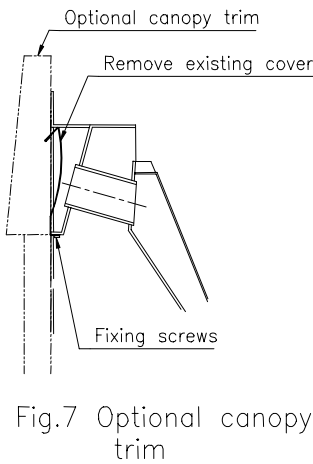

1. Secure the burner to the convection box using the two screws provided, through the holes in the front of the legs.
2. Connect the gas supply pipe to the inlet elbow.
3. The ceramic components are fragile and should be handled with care. Refer to Figs. 5 and 6 for positioning of ceramic fibre blocks and coals.
4. Place the chair shaped back ceramic on the burner, pushing it back against the upturned edge of the burner plate.
5. Place the centre ceramic on the back ceramic pushing it back to sit comfortably between the tapered sides.
6. Spring forward the slotted front plate and slide the front ceramics down as far as the stops.
7. Remove the coals from the bag; note that there are 2 sizes supplied with the burner. Place them on the ceramic blocks in accordance with Fig. 6.
8. If a flat trim or box trim has been supplied, attach it to the fire flange by means of the magnets. If the optional canopy trim has been supplied, first remove and discard the existing front cover by undoing the two screws in its bottom edge, then secure the canopy trim using the same fixings. (See Fig. 7)

**Note:** The flat trim and optional canopy trim cannot be used with the spacer frame.

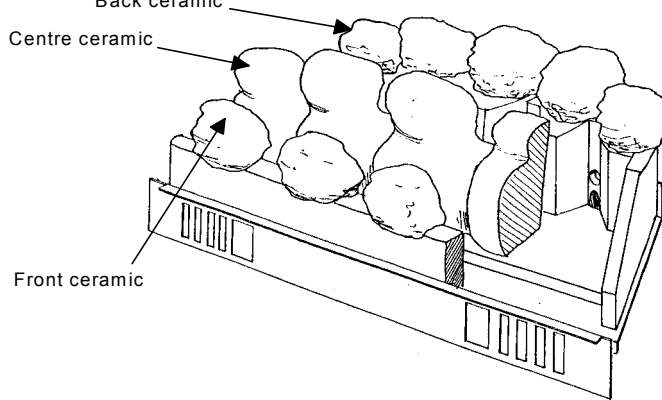

Fig.5 Assembling the ceramic blocks

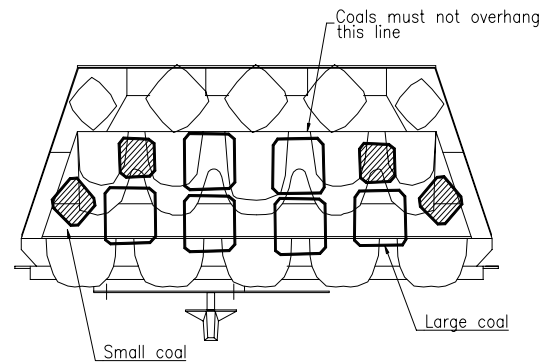
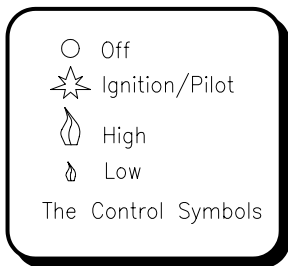

Fig.6 Placing the loose coals

## Leak test & pressure test



1. Turn on the main gas supply and check for gas soundness.
2. Remove pressure test screw, and fit pressure gauge to pressure test point.
3. Light the fire (see next section).
4. Turn control knob anti-clockwise to **High** position.
5. When the control knob is in the **High** position, you should have a gas pressure of 19.0mbar  $\pm$  1.0mbar when using natural gas and 36.5mbar for propane.
6. Extinguish the fire by turning the control knob clockwise to the **Off** position.
7. Remove the pressure gauge and replace the pressure test screw. Check again for gas soundness.
8. Fit the front fret by hooking the support lugs at each end over the slotted front plate on the burner (if using a Straxgas fret), or place an alternative front fret in front of the burner.

**Note:** If a fret from another manufacturer is being used, it must comply with the minimum free area requirements of Fig. 1.

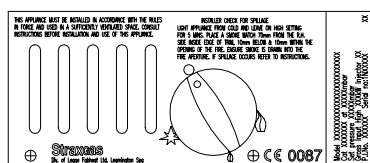

Fig.9 Data badge plate - propane version

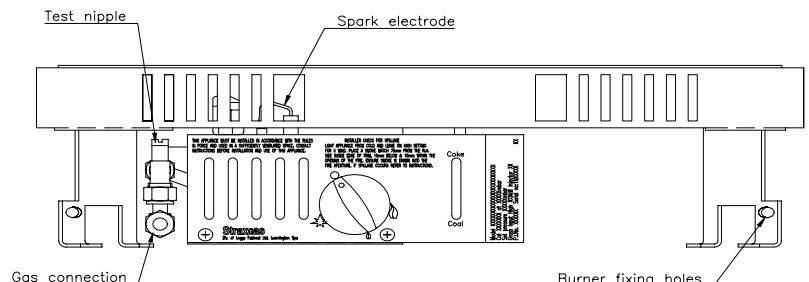

Fig. 8 The data badge plate & test

### **Lighting the fire**

The appliance Data Badge is positioned in front of the burner behind the fret and carries the control knob positions (Fig. 8 or 9 depending on gas type). The full lighting procedure is as follows:

1. Push control knob in as far as possible on gas control.
2. Turn knob anti-clockwise until a click is heard. The knob will stop at the ignition position and a spark should be seen at the tip of the ignition probe. At the same time the pilot flame should light. **KEEP THE KNOB PRESSED IN FOR 10 SECONDS.** If the pilot should fail to light, turn the control knob clockwise to the 'off' position, wait 3 minutes and repeat the procedure.
3. When the pilot flame is alight the control knob should be allowed to spring out slightly. Turn the knob fully anti-clockwise to the high position. The pilot flame should then ignite the main fire.
4. The height of the flames can be adjusted by turning the control knob between the low and high positions. Note that the knob 'latches' in position at either end of this movement and must be pushed in slightly before it can be turned.
5. The appearance of the flames can be altered by means of the air adjustment lever positioned to the right of the control knob (natural gas version only). Moving the lever up will admit more air and produce a 'coke fire' effect. Moving it down will close off some of the air and simulate a 'coal fire' with flickering flames.
6. To turn the fire off, depress the knob slightly and turn it to the pilot position.
7. To completely extinguish the fire depress the knob slightly and turn to the 'Off' position.

### **Check for clearance of products of combustion**

1. Light the fire.
2. Close all windows and doors.
3. After approximately 5 minutes place a smoke match 70mm from the right hand side, inside edge of the trim, 10mm below and 10mm within the opening of the fire as shown in Fig. 10, 10a, & 10b. Ensure that the smoke is drawn into the fire aperture. If spillage is detected, operate the fire for a further 10 minutes and repeat the test. If spillage is still detected introduce ventilation into the room by opening a window or door. If spillage is no longer detected then purpose made ventilation with a minimum area of 100 sq.cm must be provided. If after introducing ventilation into the room spillage is still detected, remove the restrictor plate if fitted (see Fig. 3) and retest for spillage. If spillage is still detected the cause must be discovered and the fault corrected. If the fault cannot be corrected, disconnect the gas supply to the appliance and seek expert advice. Possible causes of spillage are chimney restrictions, or an incorrect cowl or terminal.
4. If there is an extraction fan in a nearby room then the spillage test must be repeated with the fan turned on and any interconnecting doors between the fire and the fan location left open.

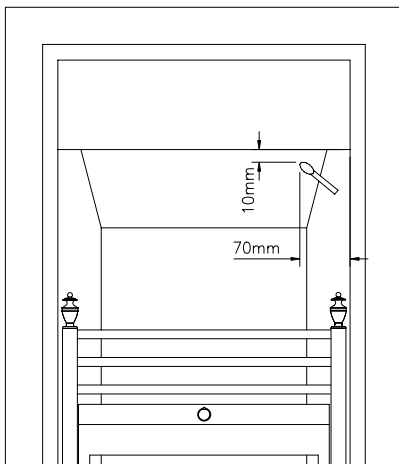

Fig.10

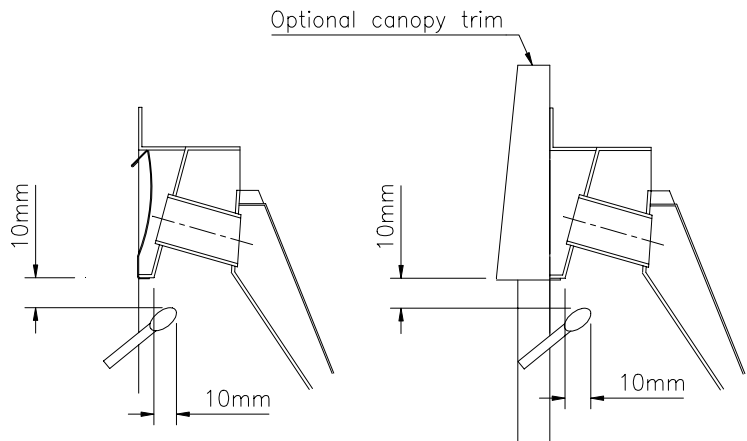

Fig.10a

Fig.10b



---

## Instruct the user

1. Hand over these Installation Instructions and the User Instructions to the person who is going to use the fire and explain how to light and operate the appliance. Explain how the fire may be lit, if necessary, by means of a long spill or taper.
2. Make certain that the user is aware that the ceramic blocks and coals must be located in accordance with the instructions, and that the appliance should be serviced at regular intervals by a competent person to ensure continued safe operation.
3. Explain that this appliance is fitted with an oxygen depletion sensor incorporated into the pilot body. Should the fire repeatedly extinguish itself, the cause should be sought and remedied as this may indicate spillage into the room of combustion products.
4. Indicate the tie-on warning label, which the customer must remove and read.
5. Advise the user that any smell given off by the appliance will clear away after a little use.
6. Point out that these instructions must be retained in a safe place for future use.

---

## Maintenance

Servicing should be carried out regularly by a competent person in accordance with these instructions and the relevant regulations, to ensure the safe and correct operation of the appliance.

At least once a year check for debris in the flueway. If soot has accumulated ensure that the chimney is swept clean.

Before commencing any service or replacement of parts, turn off the main gas supply **and ensure that the fire is cold.**

When ordering spare parts please quote appliance serial number which can be found on the data badge plate.

### Ceramics

Examine the coals and ceramic blocks for signs of cracking and replace if necessary. Handle the ceramic components with care. Dust off any soot or deposits with a soft brush. Do not vacuum clean.

### Removal of burner & convection box

1. Turn off the gas supply by the isolation cock.
2. Disconnect the 8mm pipe from the elbow at the left-hand side of the burner.
3. Remove the flat trim, box trim, or optional canopy trim.
4. Remove the 2 screws holding the burner to the convection box and lift the burner out of the opening.
5. Remove the 4 screws in the flange of the convection box, and lift the box out of the opening.
6. Examine the flue for debris and clean if necessary.
7. Reassemble in the reverse order.
8. After servicing check for gas soundness.

Following a service, a check should be made for clearance of combustion products. Follow the procedure detailed in these instructions.

### Cleaning the fire

**Black paint:** Use only a clean damp cloth. Do not use any cleaning agents.

**Brass parts:** Use Brasso or Duraglit ensuring that it does not come into contact with the black paint finish.

**IMPORTANT** - The paint finish is durable and heat resistant, however it will be damaged if plaster, cement or wallpaper paste is allowed to come into contact with it. **Protect the appliance during re-building or decorating work.**

---

## Replacement of parts

Before commencing any servicing always ensure that the fire is isolated from the gas supply and that the fire is cold. After servicing always check for gas soundness.

### Replacement of gas tap/FSD/piezo igniter

1. Turn off the gas supply by isolation cock.
2. Lift off the front fret and remove the coals and ceramic blocks.
3. Remove 2 screws holding burner to box.
4. Undo multidirectional gas connection.
5. Remove burner from the appliance.
6. Pull off control knob.
7. Remove the 2 screws securing the Data Badge plate and remove the plate.
8. Disconnect ignition lead to the igniter unit.
9. Disconnect all 3 gas connections to gas valve as well as the connection to the thermocouple.
10. Remove 2 screws securing the valve to the mounting bracket, and discard old tap/FSD/piezo igniter complete.
11. Assemble the new tap/FSD/piezo igniter on the mounting bracket. Ensure that the filter is in position in the pilot outlet orifice on the tap body.
12. Reassemble the appliance in reverse order.
13. Replace the ceramic blocks and coals (see Figs. 5 and 6).
14. Turn on the gas supply and check for soundness.

*Note: The igniter is not replaceable separately.*

### Replacement of main injector

1. Repeat operations 1 - 5, as described for 'Replacement of gas tap/FSD/piezo igniter'.
2. Remove gas pipe from gas valve to injector.
3. Unscrew injector and replace, making certain that the jet size stamping corresponds to the specification on the Data Badge plate.
4. Reassemble in reverse order.
5. Turn on the gas supply and check for soundness.

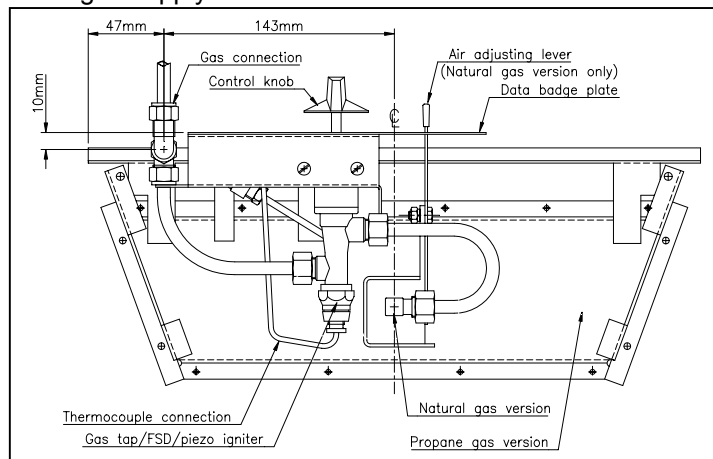

Fig. 11 Underside of burner

### Replacement of ignition & pilot assembly

1. Repeat operations 1 - 7, as described for 'Replacement of gas tap/FSD/piezo igniter'.
2. Disconnect thermocouple connection to the gas tap/FSD/piezo igniter.
3. Disconnect pipe from base of pilot burner tube.
4. Pull off connector on the base of the igniter probe.
5. Remove 2 screws on gas burner and remove ignition unit complete.
6. Fit new pilot assembly and reassemble in reverse order.
7. Turn on the gas supply and check for soundness.
8. Check operation of ignition system.

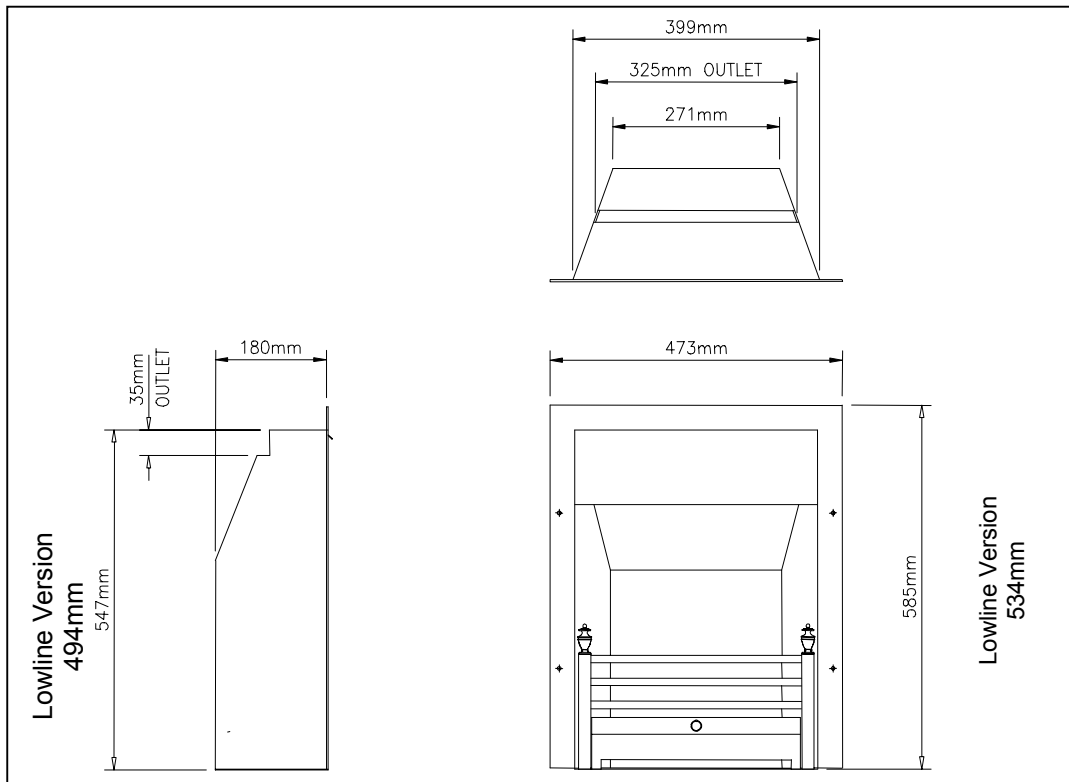

Fig. 12 Theme Plus outline drawing without trim

#### SPARE PARTS

When ordering spare parts please quote part numbers as listed below:

	NATURAL GAS	L.P.G. (Propane)
Gas tap / FSD / piezo igniter	BV50023	BV50147
Oxypilot assembly	BA50004	BA50041
Injector	BI70800	BI70530
Back ceramic	BC11300	BC11300
Centre ceramic	BC11296	BC11296
Front ceramic - set of 2	BC11295	BC11295
Set of 10 loose coals	BC50032	BC50032

NOTE: No liability can be accepted unless this product has been installed and operated strictly in accordance with these manufacturer's instructions  
 U.K. Registered Design 2040268. British Patent Application 9414887.1  
 Design right reserved © Legge Fabheat Ltd.

