

13" (330mm) Curb Mount Installation Instructions

Rooflights & Glazing UK Ltd

Tel: 0114 4081000

Email: sales@rooflightsandglazing.co.uk

IMPORTANT: Please take the time to read through the **ENTIRE** instructions prior to starting any work. Light Pipe material is very sharp when cut. Please use extreme caution when handling the light pipe. **AVOID LEAVING THE PIPE EXPOSED TO THE SUN WITHOUT THE PROTECTIVE COATING OR DIFFUSERS IN PLACE PRIOR TO INSTALLATION.**

PARTS LIST

- A. Clear UV Protected, High Impact Polycarbonate Dome
- B. (4) Phillips Head Stainless Steel 6mm Self-Tapping Screws
- C. Black Nylon Hair Gasket (self-adhesive)
- D. (4) 38mm Phillips Head Stainless Steel Screws (USED FOR SUSPENDED CEILING INSTALLATIONS ONLY)
- E. Commercial Pure Grade Aluminium Curb Flashing
- F. (4) 38mm Phillips Head Stainless Steel Screws
- G. Heavy Duty Foil Tape
- H. Light Pipe, (2) 610mm sections
- I. White Nylon Hair Gasket (self-adhesive)
- J. (8) Phillips Head Stainless Steel 12mm Self-Tapping Screws
- K. (4) U-channel PVC self-adhesive tabs
- L. (3) Black Speed Nuts
- M. Ceiling Ring
- N. (3) 38mm Phillips Screws
- O. (2) Small Clear Polycarbonate Lenses
- P. (1) Large Clear Polycarbonate Lens
- Q. High Impact Polycarbonate Diffuser
- R. White Powder Coated Aluminium Trim Ring
- S. Silicone (Not shown)

TOOLS POSSIBLY REQUIRED

- Drywall Saw • Reciprocating Saw • Measuring Tape
- Driver & Bits • Phillips Screwdriver • Torch
- Stud Finder • Marking Pencil • Tin Snips • Wire
- Hammer • Safety Goggles • Clamp

MATERIALS/TOOLS TO BUILD CURB

- 50mm x 150mm Pressure Treated Timber. The upstand needs to stand at least 150mm above the finished waterproofing so 150mm plus may be required if this is fitted within a warm (insulated) roof.

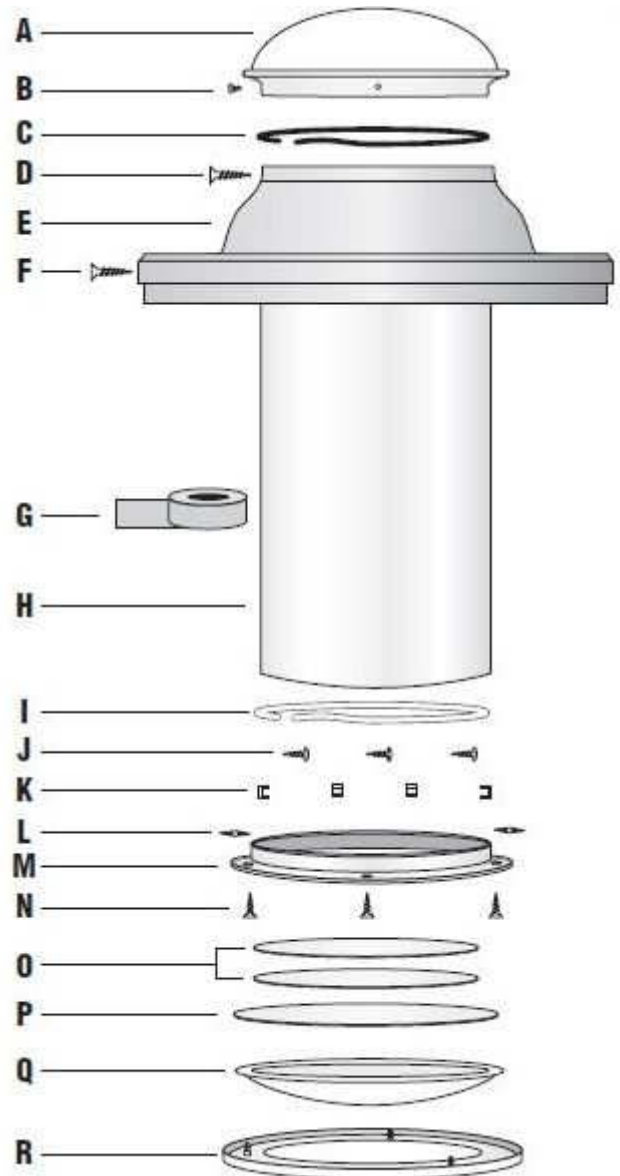

IMPORTANT: Prior to beginning the installation, it is helpful to plan the placement of the tubular skylight so that curb flashing and ceiling trim ring are aligned. Ensure that the curb is not installed over any framing trusses. **DO NOT CUT ANY STRUCTURAL FRAMING.**

INSTALLATION POINTERS

- *When determining location of the unit, southern exposure is recommended. Also consider potential problems such as objects shading the unit during certain times of the day.
- *Although adjustable elbows are available for use, straight light pipe runs result in higher light output and easier installation.
- *Prior to starting the job, cut packaging straps on the light pipe and uncoil the tubes. It is highly critical to check for obstructions above the ceiling which may hinder the installation. *If possible, visually check to ensure that there are no electrical wires or other obstructions where you plan to install the skylight. If you cannot check visually, use a piece of wire as outlined in Step 1.

Step 1

To facilitate installation, once the desired location is obtained, ensure that there are no obstructions between the roof and ceiling or on the roof. With a stud finder, if required, locate the ceiling joists and centre the ceiling ring (L) between joists as close to the desired installation area as possible. Mark the centre of the ceiling ring (L), drill a hole and insert piece of wire bent at a 90 degree angle. Rotate the wire around 360 degrees. While rotating, feel for resistance that could indicate wire runs or other obstructions.

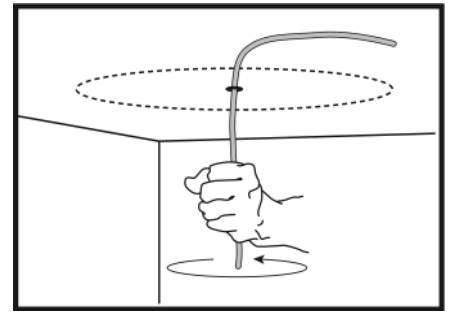

Step 2

If there are no obstructions, scribe mark around the ceiling ring inner ring (M). Using a Drywall saw, cut out the scribed mark in the ceiling plasterboard (if there are any other material in-situ then please check with our sales office for suitability – Please also check against harmful substances & products before cutting too).

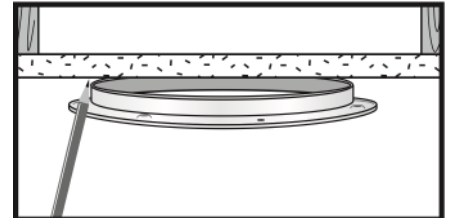

Step 3

Install the ceiling ring (M) on the ceiling. Place ceiling ring in the hole cut in Step 2. Peel the protective covering off the white horse hair gasket (I) and apply gasket to the inner lip of the ceiling ring (M). This gasket ensures a dust free fit between the light pipe and the ceiling collar. Secure the ceiling collar to ceiling by inserting a 38mm Phillips flathead screw (N) into one of the three pre-drilled dimpled holes and screwing it up through the drywall into speed nut (L) provided. Repeat this process for the other two screws.

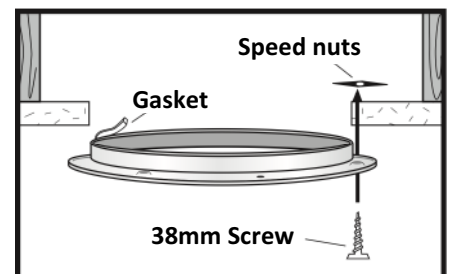

Step 4

Place a ladder under ceiling ring hole and place a torch on top of ladder. The resulting torch will mark the location for the centre of the hole. With a drill bit and appropriate extension rods, drill a pilot hole in the marked location on bottom side of roof. If attic is accessible, a plumb-bob may also be used.

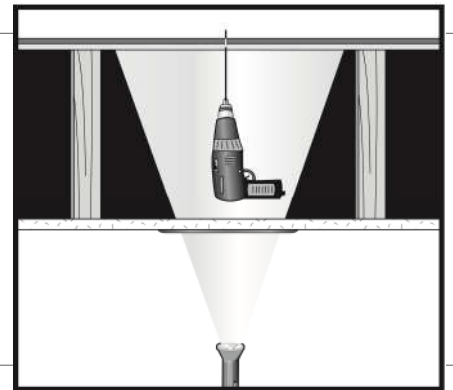

Step 5

Assemble a curb with the **outside** dimensions slightly smaller than the width of flashing (Approximately 536mm x 536mm). **The size of curb will vary depending on roofing material.** Use pressure-treated timber secured at all four corners with wood screws (use 50mm x 150mm timber - adhere to good practice codes). The upstand needs to stand at least 150mm above the finished waterproofing so 150mm plus may be required if this is fitted within a warm (insulated) roof. **PLEASE NOTE:** Do not build curb prior to being on site.

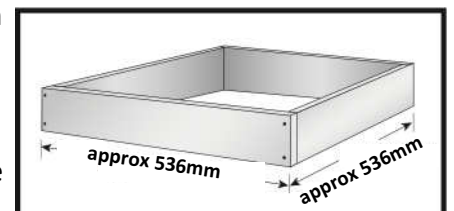

Step 6

On the roof, locate the centre of the hole drilled in Step 3. Centre the curb over the hole and ensure that the curb placement is NOT over any structural trusses. Outline the inside perimeter of the curb with a marking pencil. When using a reciprocating saw, cut out opening. **DO NOT CUT STRUCTURAL FRAMING.**



Step 7

Place curb over opening and fix into existing roofing using wood screws. If necessary, build blocking to ensure the curb is secure. Apply the appropriate waterproofing material to the curb to make the installation water tight.

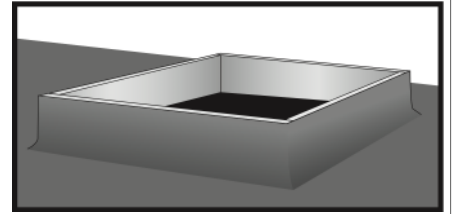

Step 8

Attach the skylight flashing (E) to the curb using the (4) 38mm Phillips head stainless steel screws (F) provided through the pre-drilled holes on the skylight flashing lip. Peel the protective backing off the black nylon horse hair gasket (C) and apply gasket to the INNER lip the flashing collar. Please bed the base curb mount on the upstand using the silicone provided (S)

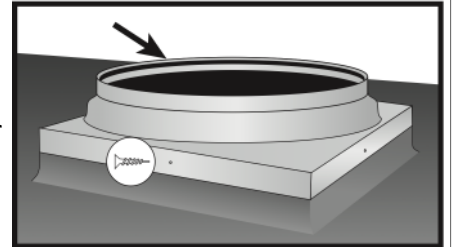

Step 9

To assemble light pipe (H), peel back the protective coating that covers the mirror coating about 25mm from the opposite edge of the double sided tape. Remove paper backing from the double-sided tape and overlap tube ends and seal edges. Put pressure on both sides of seal to ensure a good bond. Secure tube using the (2) 12mm self-tapping screws (J) provided. Then place foil tape (G) over the entire seam to strengthen seal. When joining two pipe sections together then place the crimped end into the next section of pipe. Secure with (2) 12mm self-tapping screws (J) provided and seal joints with foil tape (G).

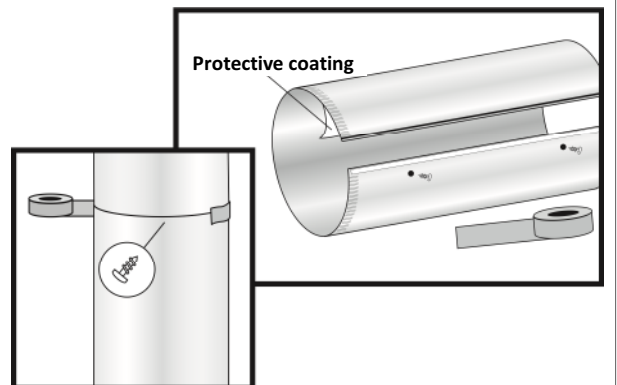

Step 10

Insert light pipe (H) through the curb-mount flashing (E) with the **crimped end down** and gently rock pipe back and forth with slight downward pressure until pipe terminates evenly with the inner collar of the ceiling ring (M). Clamp the light pipe to the flashing lip so that it does not slip down. Trim any excess light pipe with tin snips. **PLEASE BE CAREFUL WHEN TRIMMING AS THE TUBE HAS VERY SHARP EDGES**

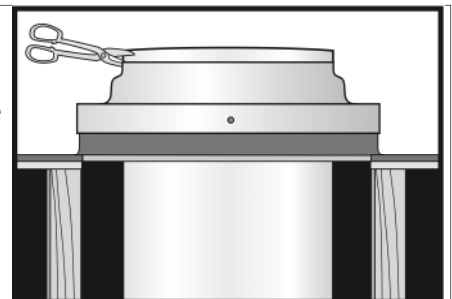

Step 11

Back inside, secure the bottom of light pipe to ceiling ring with (4) Tek screws (J).

SUSPENDED CEILING INSTALLATIONS:

Please contact our office for further advice on this type of install. This product will work in conjunction with a suspended ceiling but extra work & adaptation will be required to support the weight of the tubes.

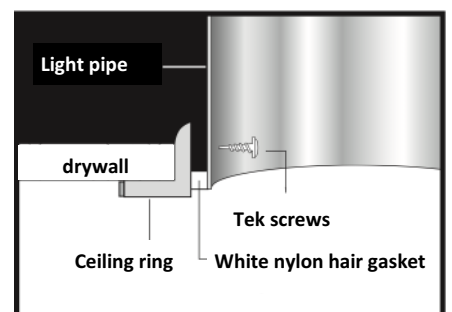

Step 12

Remove paper backing from the adhesive tape on the U-channels (K) and place 38mm from bottom of light pipe equidistant from each other so legs of the U-channels align vertically.

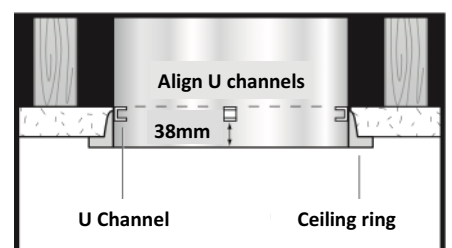

Step 13

Remove protective film from **both sides** of small lenses (**O**). Place one lens on TOP of the U-channel leg (**K**) and the other lens on the BOTTOM of U-channel leg (**K**) (see close-up).

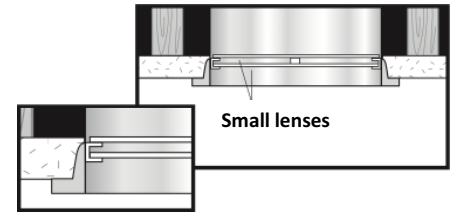

Step 14

Place the diffuser (**Q**) into the white powder coated trim ring (**R**). Remove protective film from **both sides** of large lens (**P**) and place on top of diffuser (**Q**).

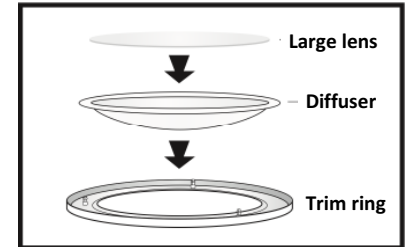

Step 15

Line up the three steel pins of the white ceiling trim ring (**R**) with the holes on the ceiling ring (**M**). Push up to snap in place.

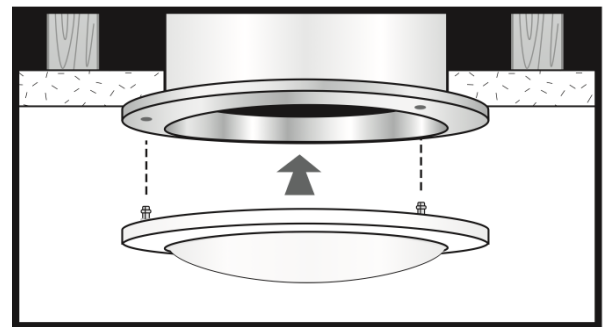

Step 16

Place the dome (**A**) on top of the flashing unit. Secure the dome to flashing by screwing in the (4) self-tapping Phillips head 6mm screws (**B**) provided into the pre-drilled holes in the dome collar.

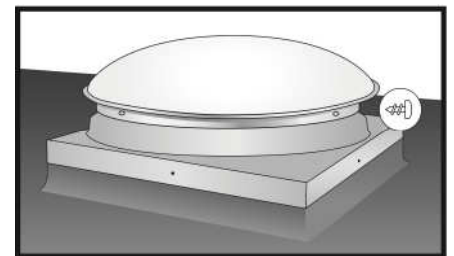

Supplied by;

Rooflights & Glazing UK Ltd
Unit 5 Ironbridge Ind. Estate
397 Retford Road
Sheffield
S13 9WA

T. 0114 4081000
F. 0114 2385511

Email: sales@rooflightsandglazing.co.uk
Web: www.rooflightsandglazing.co.uk



Comments;