

ROTOLOK

everything under control...

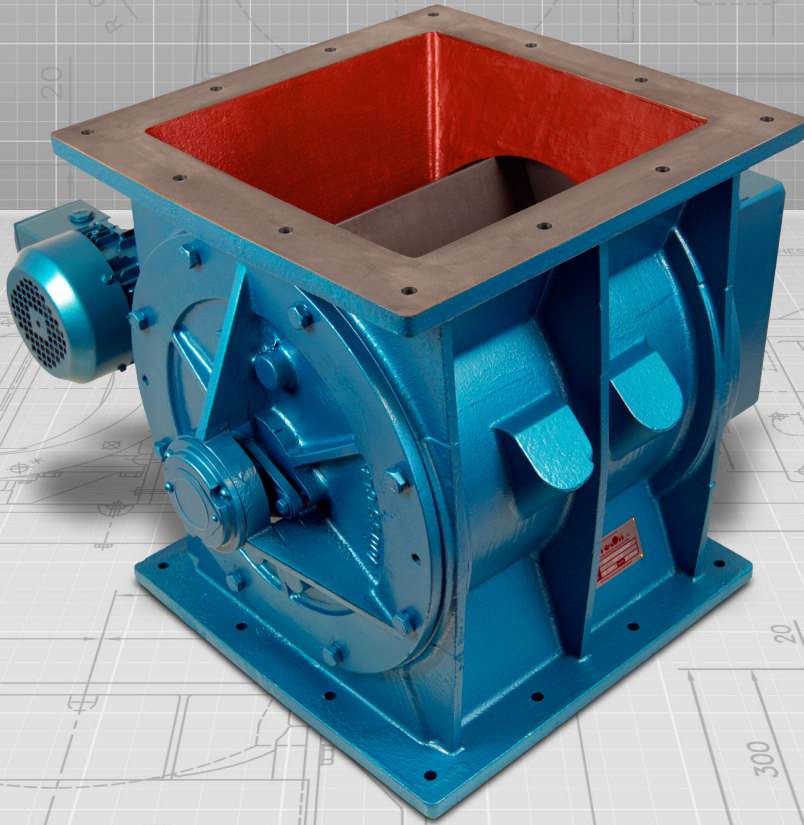

ROTOLOK USA

Industrial Ventures II
2711 Gray Fox Road
Monroe
North Carolina
28110
United States of America
Tel: +1 (704) 282 4444
Fax: +1 (704) 282 4242
www.rotolok.us
sales@rotolok.us

ROTARY VALVES & AIRLOCKS



INTRODUCTION

The prime function of a rotary valve is to regulate the flow from one chamber to another while maintaining a good airlock condition. The product is mainly in dry powder or granular form.

In the dust filtration field good airlocks are essential on cyclone and bag filter applications in order that the manufacturer's quoted high dust collection efficiencies can be maintained. Airlocks are also important in the pneumatic conveying industry, where product is regulated into a high pressure conveying line while minimising air leakage.

With Rotolok there are no double standards, all our standard valves are precision machined for close tolerances and minimal eccentricities. Pressure differentials to 20psi and temperatures to 750°F. We have made specials to handle temperatures covering 2190°F and pressures to 350psi.

STANDARD FEATURES

- Maximum number of blades in contact with body at one time without affecting throughput.
- Good throat opening at valve entry allowing high pocket filling efficiency.
- Minimum clearance at rotor tips and sides with body.
- Robust body adequately stiffened to prevent distortion.
- Heavy shaft diameters minimising deflection.
- Outboard bearings for non-contamination.
- Packing gland type seals.
- Maximising valve speed to 25 rpm -prolonging life, ensuring good throughput.
- Precision machining of components.

SPECIFICATION

Bodies

Cast Iron, Stainless Steel or Aluminum precision bored.

End Covers

Cast Iron, Stainless Steel or Aluminum spigot located in body for concentricity.

Rotor

Fabricated Mild or Stainless Steel.

Shaft Seal

Gland type with PTFE packing.

Bearings

Sealed-for-life ball type rigged outboard or high temperature above 480°F.

Drive

NEMA Frame C-Face TEFC motor mounted to parallel shaft gear reducer sidewall mounted to valve body complete with taper lock sprockets and chain all in an enclosed OSHA approved guard'

OPTIONS

- Quick Release Rotors
- Direct Coupled Drives
- Air Purge Glands
- Body Vents
- Inlet Vent Hoppers
- Dropout Boxes
- V.S. Drives
- Speed Switches
- Explosion Proof Motors
- Shear Plate Deflectors
- Tungsten Carbide Coating
- Hard Chrome Internals etc.

Quick Release Rotor Detail

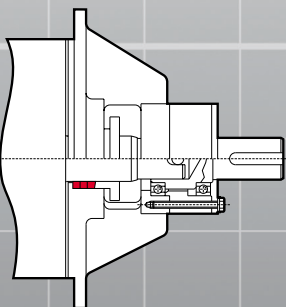

Air Purge Gland

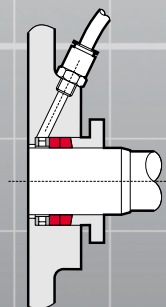

Body Vent

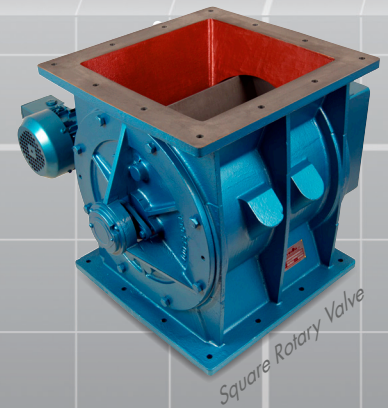
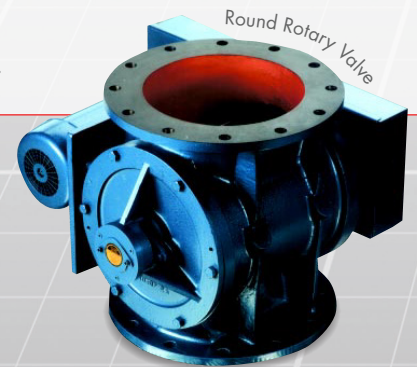
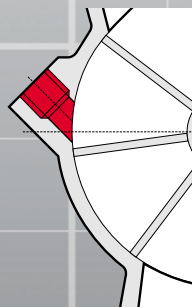

Planning-in detail for general guidance only

(To cover safety aspects ask for our safety leaflets)

Drillings are Rotolok standards. Variations can be made.

SQUARE INLET

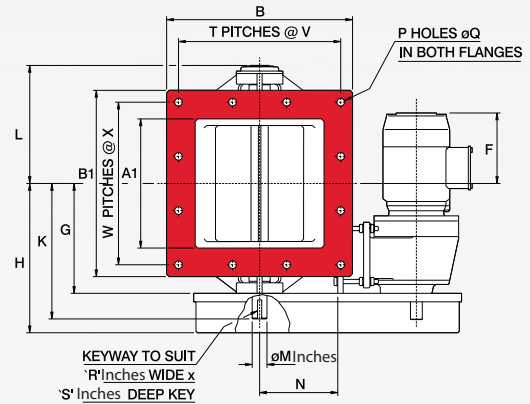
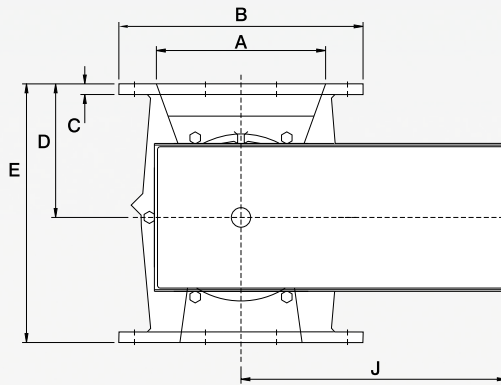

| Valve Size | A | A1 | B | B1 | C | D | E | F | G | H | J | K | L | M | N | P | Q | R | S | T | V | W | X | H.P. | |
|------------|--------|--------|--------|--------|-----|--------|--------|-------|--------|--------|--------|--------|--------|-------|--------|-------|------|-------|------|----------------|---------|-------|---------|-------|---|
| 5 | 5 | 5 | 8 7/8 | 8 7/8 | 1/2 | 3 7/8 | 7 3/4 | 7 7/8 | 6 1/4 | 9 1/8 | 16 | 8 7/8 | 7 | 1 1/8 | 4 7/8 | 3/16 | 3/16 | 3/16 | 1/4 | ON APPLICATION | | | 1 1/2 | | |
| 6 | 6 | 6 | 9 7/8 | 9 7/8 | 1/2 | 5 1/2 | 11 | 7 7/8 | 6 3/4 | 9 3/4 | 16 | 9 1/4 | 7 3/4 | 1 1/8 | 4 3/8 | 1/2 | 1/2 | 3/16 | 1/4 | 1/8 | 2 3/4 | 1/8 | 2 3/4 | 1 1/2 | |
| 8 | 8 | 8 | 11 7/8 | 11 7/8 | 5/8 | 6 1/2 | 13 | 6 3/4 | 7 7/8 | 10 3/4 | 16 | 10 1/4 | 8 7/8 | 1 1/8 | 5 7/8 | 1/2 | 1/2 | 3/16 | 1/4 | 1/8 | 3 3/8 | 1/8 | 3 3/8 | 1 1/2 | |
| 10 | 10 | 10 | 13 1/4 | 13 1/4 | 5/8 | 7 1/2 | 15 | 7 7/8 | 9 | 12 3/4 | 18 1/2 | 11 1/2 | 9 7/8 | 1 3/8 | 6 3/8 | 1/2 | 3/16 | 3/8 | 3/16 | 1/8 | 4 | 1/8 | 4 | 1 | |
| 12 | 12 | 12 | 15 3/4 | 15 3/4 | 1/2 | 9 1/8 | 18 1/8 | 6 3/4 | 10 1/4 | 13 7/8 | 18 1/2 | 12 7/8 | 11 | 1 7/8 | 7 1/8 | 1/2 | 1/2 | 3/8 | 3/16 | 1/8 | 4 1/8 | 1/8 | 4 1/8 | 1 | |
| 14 | 14 | 14 | 18 1/2 | 18 1/2 | 3/4 | 10 1/8 | 20 1/4 | 6 3/4 | 10 3/4 | 14 3/8 | 20 1/2 | 13 | 11 7/8 | 1 7/8 | 8 1/8 | 1/2 | 1/2 | 3/8 | 3/16 | 1/8 | 5 1/2 | 1/8 | 5 1/2 | 1 | |
| 16 | 16 | 16 | 21 1/4 | 21 1/4 | 3/4 | 11 1/8 | 22 7/8 | 4 1/2 | 13 | 16 3/4 | 24 1/2 | 15 7/8 | 13 7/8 | 2 | 9 1/4 | 1/2 | 1/16 | 3/8 | 3/8 | 1/8 | 6 1/2 | 1/8 | 6 1/2 | 1 1/2 | |
| 18 | 18 | 18 | 24 | 24 | 3/4 | 12 3/8 | 24 7/8 | 3 3/4 | 14 | 17 3/4 | 24 1/2 | 16 7/8 | 14 7/8 | 2 | 11 1/4 | 1/2 | 1/16 | 3/8 | 3/8 | 1/8 | 7 3/8 | 1/8 | 7 3/8 | 2 | |
| 20 | 20 | 20 | 25 3/4 | 25 3/4 | 3/4 | 13 3/8 | 26 3/8 | 5 | 15 | 18 3/4 | 27 1/2 | 17 7/8 | 15 7/8 | 2 | 11 7/8 | 3/8 | 1/16 | 3/8 | 3/8 | 1/8 | 5 13/16 | 3/16 | 5 13/16 | 2 | |
| 24 | 24 | 24 | 29 1/2 | 29 1/2 | 3/4 | 15 | 29 1/2 | 4 1/2 | 17 | 20 3/4 | 27 1/2 | 19 3/4 | 17 3/4 | 2 | 13 3/8 | 3/8 | 1/16 | 3/8 | 3/8 | 1/8 | 6 13/16 | 3/16 | 6 13/16 | 3 | |
| 30 | 29 1/2 | 29 1/2 | 39 3/8 | 39 3/8 | 1 | 19 3/8 | 39 3/8 | 3 | 19 3/4 | 25 1/4 | 35 3/8 | 23 3/8 | 20 1/2 | 2 3/4 | 17 1/8 | 15/16 | 1/16 | 3/8 | 3/8 | 1/2 | 1/4 | 5 7/8 | 1/4 | 5 7/8 | 3 |
| 36 | 36 | 36 | 45 7/8 | 45 7/8 | 1 | 23 3/8 | 47 1/4 | -1 | 23 7/8 | 29 1/2 | 39 3/8 | 27 7/8 | 24 3/4 | 2 3/4 | 21 1/4 | 15/16 | 7/8 | 13/16 | 1/2 | 1/4 | 6 7/8 | 1/4 | 6 7/8 | 5 | |

CIRCULAR INLET

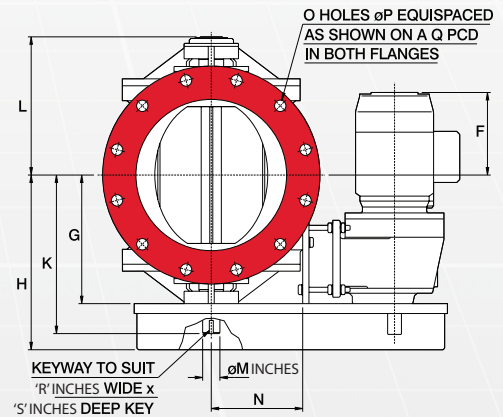
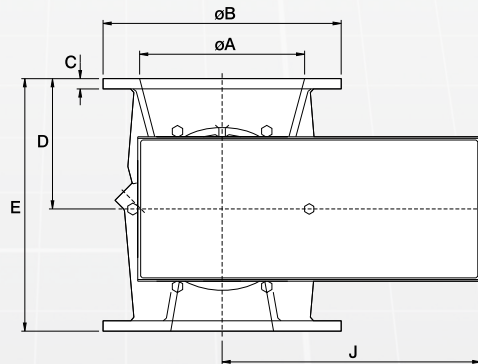

| Valve Size | A | B | C | D | E | F | G | H | J | K | L | M | N | O | P | Q | R | S | H.P. |
|------------|-------|--------|-----|--------|--------|-------|--------|----------------|--------|--------|--------|-------|--------|-------|--------|--------|-------|------|-------|
| 2 | 2 | 6 | 3/8 | 2 1/2 | 4 3/4 | * | 3 | ON APPLICATION | | | | | | | | | | | |
| 3 1/2 | 3 3/8 | 7 1/2 | 3/8 | 3 3/8 | 6 1/4 | * | 4 3/8 | ON APPLICATION | | | | | | | | | | | |
| 5 | 5 | 9 1/2 | 1/2 | 4 1/4 | 8 1/2 | 7 3/8 | 6 3/8 | 9 3/8 | 16 | 8 7/8 | 7 | 1 1/8 | 5 7/8 | 3/16 | 1 1/16 | 7 7/8 | 3/16 | 1/4 | 1 1/2 |
| 6 | 6 | 11 1/4 | 1/2 | 5 1/8 | 10 7/8 | 7 3/8 | 6 3/8 | 9 3/8 | 16 | 9 1/4 | 7 7/8 | 1 1/8 | 5 7/8 | 3/16 | 7/8 | 9 1/2 | 3/16 | 1/4 | 1 1/2 |
| 8 | 8 | 12 1/2 | 1/2 | 6 1/4 | 12 1/4 | 6 3/8 | 7 7/8 | 10 3/4 | 16 | 10 1/4 | 8 7/8 | 1 1/8 | 5 7/8 | 3/16 | 1 1/16 | 11 | 3/16 | 1/4 | 1 1/2 |
| 10 | 10 | 14 1/2 | 5/8 | 7 7/8 | 15 | 8 | 9 | 12 3/4 | 18 1/2 | 11 7/8 | 9 3/4 | 1 7/8 | 6 3/8 | 3/16 | 1 1/16 | 12 3/8 | 3/8 | 3/16 | 1 |
| 12 | 12 | 17 3/4 | 3/4 | 9 1/2 | 18 3/8 | 6 3/4 | 10 3/4 | 13 7/8 | 18 1/2 | 12 7/8 | 11 | 1 7/8 | 7 1/8 | 1/2 | 7/8 | 15 1/2 | 3/8 | 3/16 | 1 |
| 14 | 14 | 21 | 3/4 | 10 3/8 | 20 1/2 | 6 3/4 | 10 3/4 | 14 3/8 | 20 1/4 | 13 | 11 3/4 | 1 7/8 | 8 1/8 | 1/2 | 7/8 | 17 1/2 | 3/8 | 3/16 | 1 |
| 16 | 16 | 21 1/4 | 3/4 | 11 7/8 | 22 7/8 | 4 3/4 | 13 | 16 3/4 | 24 1/2 | 15 7/8 | 13 3/8 | 2 | 9 1/4 | 1/2 | 7/8 | 19 1/2 | 3/16 | 3/8 | 1 1/2 |
| 18 | 18 | 25 | 3/4 | 12 3/8 | 24 3/4 | 4 | 14 | 17 3/4 | 24 3/4 | 16 1/2 | 14 3/8 | 2 | 11 1/4 | 3/8 | 1 1/4 | 22 3/4 | 3/16 | 3/8 | 2 |
| 20 | 20 | 27 1/4 | 3/4 | 13 3/8 | 26 3/8 | 5 | 15 | 18 3/4 | 27 1/2 | 17 7/8 | 15 7/8 | 2 | 11 7/8 | 13/16 | 1 1/4 | 25 | 3/16 | 3/8 | 2 |
| 24 | 24 | 32 | 3/4 | 15 3/8 | 30 | 5 | 17 | 20 3/4 | 27 1/2 | 19 3/4 | 17 7/8 | 2 | 13 3/8 | 13/16 | 1 3/8 | 29 1/2 | 3/16 | 3/8 | 3 |
| 30 | 30 | 38 3/4 | 1 | 19 3/8 | 39 3/8 | 2 | 19 3/4 | 25 1/2 | 35 7/8 | 23 3/8 | 20 1/2 | 2 3/4 | 17 1/8 | 1 1/8 | 1 3/8 | 36 | 13/16 | 1/2 | 3 |

Rotolok manufactures and casts other valve sizes with rectangular & other non-standard inlets. If you are looking for something considered special it may be in our library of valves.

STANDARD ROTORS

Rotolok basically manufactures four types of rotor as outlined, but to give the plant engineer flexibility many variations can be accommodated, e.g. closed/tipped, reduced volume, staggered blades etc. We will make a rotor to suit your application - not our production.

VALVE SELECTION

The chart below gives theoretical and estimated throughputs on the basis of rotor speed. The theoretical figure is determined by the swept volume of the valve and is calculated on a pocket fillage of 100%. In practice this is seldom achieved as density, product characteristics, pressure differential, feeding methods, all affect the valve throughput efficiency. On these considerations the estimated figures are assessed and are more

acceptable for selecting the correct valve. e.g. Select a valve to handle 7 tons/hour of flour at 35 lb/cu. ft. Volume required = 7.0 x 2000 ÷ 35 = 400 cu.ft/hr.

From the chart, two valves economically cover this:

1. 10" Valve at 22 rpm.
2. 12" Valve at 10 rpm.

With flour being sluggish and the 10" unit on its uppermost speed, the selection is limited to the 12" unit.

Factors other than throughput can sometimes determine valve selection. This is particularly true on cyclone and filter applications where the valve inlet size to prevent bridging can become the governing factor, always with the proviso that the potential valve discharge rate exceeds the collecting rate.

| CAPACITY CHART IN CUBIC FEET/HR | | | | | | | | | | | | | |
|---------------------------------|------|------|------|-------|-------|-------|-------|-------|-------|-------|-------|-------|-----------|
| 36" | 1158 | 5792 | 9266 | 11583 | 13900 | 16216 | 18533 | 20849 | 23166 | 25483 | 27799 | 30116 | 100% |
| | 1158 | 5792 | 8803 | 10425 | 12232 | 13946 | 15568 | 16888 | 18069 | 18857 | 19737 | 20479 | Practical |
| 30" | 681 | 3405 | 5448 | 6809 | 8171 | 9533 | 10895 | 12257 | 13619 | 14981 | 16343 | 17704 | 100% |
| | 681 | 3405 | 5176 | 6128 | 7190 | 8198 | 9152 | 9928 | 10623 | 11086 | 11604 | 12039 | Practical |
| 24" | 356 | 1780 | 2848 | 3560 | 4272 | 4984 | 5696 | 6408 | 7120 | 7832 | 8544 | 9255 | 100% |
| | 356 | 1780 | 2706 | 3204 | 3759 | 4286 | 4785 | 5190 | 5554 | 5796 | 6066 | 6293 | Practical |
| 20" | 205 | 1024 | 1639 | 2048 | 2458 | 2868 | 3277 | 3687 | 4097 | 4506 | 4916 | 5326 | 100% |
| | 205 | 1024 | 1557 | 1843 | 2163 | 2466 | 2753 | 2968 | 3196 | 3334 | 3490 | 3622 | Practical |
| 18" | 149 | 743 | 1189 | 1487 | 1784 | 2082 | 2379 | 2676 | 2974 | 3271 | 3568 | 3866 | 100% |
| | 149 | 743 | 1130 | 1338 | 1570 | 1791 | 1998 | 2168 | 2320 | 2420 | 2533 | 2629 | Practical |
| 16" | 104 | 519 | 830 | 1037 | 1245 | 1452 | 1660 | 1867 | 2075 | 2282 | 2490 | 2697 | 100% |
| | 104 | 519 | 789 | 933 | 1096 | 1249 | 1394 | 1512 | 1618 | 1689 | 1768 | 1834 | Practical |
| 14" | 65.2 | 326 | 521 | 652 | 782 | 912 | 1043 | 1173 | 1303 | 1434 | 1564 | 1694 | 100% |
| | 65.2 | 326 | 495 | 587 | 688 | 784 | 876 | 950 | 1016 | 1061 | 1110 | 1152 | Practical |
| 12" | 45.4 | 227 | 363 | 454 | 545 | 636 | 727 | 818 | 908 | 999 | 1090 | 1181 | 100% |
| | 45.4 | 227 | 354 | 409 | 480 | 547 | 611 | 663 | 708 | 739 | 774 | 803 | Practical |
| 10" | 25.6 | 128 | 205 | 256 | 307 | 359 | 410 | 461 | 512 | 564 | 615 | 666 | 100% |
| | 25.6 | 128 | 195 | 230 | 270 | 309 | 344 | 373 | 399 | 417 | 437 | 453 | Practical |
| 8" | 12.7 | 63 | 101 | 127 | 152 | 177 | 203 | 2288 | 253 | 279 | 304 | 329 | 100% |
| | 12.7 | 63 | 96 | 114 | 134 | 152 | 171 | 185 | 197 | 206 | 216 | 224 | Practical |
| 6" | 5.0 | 25 | 40 | 50 | 60 | 71 | 81 | 91 | 101 | 111 | 121 | 131 | 100% |
| | 5.0 | 25 | 38 | 45 | 53 | 61 | 68 | 74 | 79 | 82 | 86 | 89 | Practical |
| 5" | 2.8 | 14 | 23 | 28 | 34 | 39 | 45 | 51 | 56 | 62 | 68 | 73 | 100% |
| | 2.8 | 14 | 22 | 25 | 30 | 34 | 38 | 41 | 44 | 46 | 48 | 50 | Practical |
| 3" | .96 | 4.8 | 7.7 | 9.6 | 11.5 | 13.4 | 15.4 | 17.3 | 19.2 | 21.1 | 23 | 25 | 100% |
| | .96 | 4.8 | 7.3 | 8.6 | 10.1 | 11.5 | 12.9 | 14 | 15 | 15.6 | 16.3 | 17 | Practical |
| 2" | .228 | 1.1 | 1.8 | 2.3 | 2.7 | 3.2 | 3.6 | 4.1 | 4.6 | 5.0 | 5.5 | 5.9 | 100% |
| | .228 | 1.1 | 1.7 | 2.1 | 2.4 | 2.7 | 3 | 3.3 | 3.6 | 3.7 | 3.9 | 4 | Practical |
| | 1 | 5 | 8 | 10 | 12 | 14 | 16 | 18 | 20 | 22 | 24 | 26 | |

Rotor Speed RPM

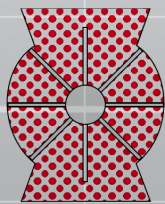

Open fixed bladed rotor
Suitable for general range of products and particularly suitable on conveying systems to pressure of 15 psi. Sealing is by packing gland type with standard packing being fluon or equal.

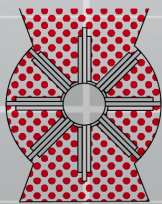

Open adjustable bladed rotor
Suitable for most products and pressure differentials to 20 psi. Blades are adjustable, reversible and replaceable and can be supplied in mild steel, PVC rigid, PTFE, stainless steel etc. to suit particular product. Can be adapted to suit highly abrasive materials.

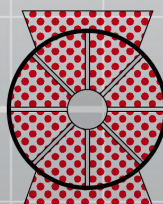

Closed rotor
Suitable for general use on filters, cyclones, silos, screw conveyors and on low pressure conveying systems. Sealing by means of packing gland.

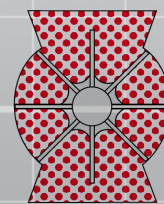

Scalloped rotor
Particularly suitable for "sticky" materials and discharge can be further aided by the application of PTFE coating, generally used in food processes where no product build-up can be tolerated. Pressures to 15 psi are applicable.

NOTES

Throughput

Certain products when fluidised can greatly exceed the conservative rating and on some applications, e.g. cement, 100% pocket fillage has been known to occur - similarly light products up to 15lb/cu. ft. the opposite effect can happen.

Temperature

Note: On any application above ambient (70°F) it is important to specify operating temperatures so rotor compensation for expansion can be adjusted as necessary

Conversions

Divide cubic feet/hr by 35.3 to obtain cubic metre/hr.

Theoretical capacity 100% pocket fillage efficiency.

Conservative estimates.