

OVER 150
NEW PRODUCTS!

Your
Source for **Effective**
Display and Merchandising



 **marketingIMPACT**
LIMITED

www.displaypeople.com



Marketing Impact is North America's premier supplier of retail merchandising and display products. Since we opened our doors in 1986, our focus has been on maximizing sales and simplifying inventory management on the shelves and floors of retail environments. From cutting-edge custom displays to common merchandising products and accessories, we are the supplier of choice for retailers of all kinds. For many reasons we are your source for effective display and merchandising.

- We offer a range of more than 4,000 functional, adaptable, innovative merchandising and display products with complimentary accessories.
- A large onsite inventory allows us to ship most orders in 24 hours or less.
- Our modern 58,000 square foot facility sports the capability to manufacture most of what we sell. Our team of creative designers and engineers have years of experience in continually developing functional and effective displays and merchandising products.
- Innovation and creativity have no boundaries at MIL since our constant research of trends always keep us a step ahead of the global marketplace.
- Outstanding customer service has always been a source of pride with our experienced representatives. They are always ready to provide fast and effective solutions to your merchandising challenges, and educated answers to any questions that you may have.

This catalogue is full of comprehensive display and merchandising products. No matter what your merchandising display requirements or needs, Marketing Impact has the products to help you maximize sales. If you can't find exactly what you're looking for, please call us! Our knowledgeable staff will work with you to create the ideal merchandising solution.

TABLE OF CONTENTS

P. SIGNHOLDER SYSTEMS

- 14 Signholder Frames
- 16 Aluminum Snap Frames
- 16 Reusable Magic Frames
- 17 Modular Signholder Systems
- 19 The Wobbler Sign System
- 20 Mounting Accessories & Bases
- 30 In-Store Advertising Clips
- 31 Coil Mounts
- 32 Floor Standing Signholders
- 34 Popular Signholder Kits
- 38 Signholder Solutions
- 41 Clear Signholder Solutions
- 43 Hanging Boards
- 44 Aisle Markers
- 47 Card Clips
- 50 Signholder & Base Clips
- 53 Clip-Ons

P. BROCHURE HOLDER & CUSTOM ACRYLIC

- 56 Brochure & Business Card Holders
- 61 Acrylic Accessories
- 62 Acrylic Engraving

P. DATA STRIPS & LABEL HOLDERS

- 64 Shelf Ticket Mouldings

P. MODULAR MERCHANDISING SYSTEMS

- 74 Modular Merchandising System
- 74 Spring-Loaded Pushers
- 76 Shelf Dividers
- 80 Shelf Management Mats & Trays
- 81 Snap Bars
- 82 Pusher Fronts & Paddles
- 84 Frame Holders
- 84 Hook Pushers
- 85 CD / DVD Pusher
- 87 Popular Shelf Pusher Kits
- 90 Kwickload™ Pusher System
- 95 Shelf Cooler Baffle / Support Bar
- 95 Kwickload™ Cooler Baffle
- 96 Hanging / Shelf Mounted Pusher System
- 98 Extruded Gravity Feed / Pusher System
- 104 Cooler Merchandising

P. SECURITY / LOSS PREVENTION

- 106 Security Pusher System
- 108 Lock Box
- 109 Security Flip Door
- 110 Secure Merchandiser Shelf
- 111 Invisi-Shield™
- 112 Fort Knox™ Security

P. HANGING RETAILERS & HOOKS

- 114 The MAX Hanging Merchandising System
- 118 Strip Retailers and Accessories
- 121 Display Components
- 127 Hooks, Hangers & Label Holders
- 130 Hang Tabs
- 132 Ceiling Hangers
- 134 Suction Cups
- 135 Fasteners
- 136 Floor Standing Merchandiser

P. MERCHANDISING SOLUTIONS

- 140 Multi-Purpose Adjustable Bin & Accessories
- 142 Cosmetic Merchandising Tray
- 142 Slatwall / Pegboard Accessories
- 145 Cooler Merchandising Racks
- 146 Produce Bin
- 147 Cool-Ads™
- 148 Inline Merchandising
- 150 Skid Fender
- 151 More Merchandising Ideas
- 152 Standard Corrugated Displays

P. BEVERAGE SYSTEMS

- 154 Whole Bean Merchandising
- 155 Gravity Pot & Merchandise Stands
- 156 Condiment Trays
- 157 Cup / Lid Organizers
- 158 Accessories

P. LIGHTING SYSTEMS

- 160 Efficient & Innovative Retail Lighting Solutions

P. CUSTOM DISPLAY

- 164 Counter Displays
- 165 Floor Displays
- 166 Sidewinders
- 166 Hanging Retailers & Ear Muffs
- 167 Bird Bath Displays
- 167 Skids and Gondolas
- 167 Vacuum Formed Displays
- 168 Injection Moulded Modular Displays
- 168 Custom Acrylic

Ordering
made
easy!

HEAD OFFICE
(905) 738 - 0888

TOLL FREE
(800) 410 - 0264

FAX
(905) 738 - 1334

EMAIL
sales@displaypeople.com



**BE SURE TO VISIT OUR WEBSITE
REGULARLY TO SEE OUR LATEST
INNOVATIONS.**

www.displaypeople.com

"Michael and the team at Marketing Impact have done a great job for Pamida. They have assisted us with many projects and have given creative, yet economical options for us to choose from."

Theresa Langabeer

Director of In-Store Marketing & Space Planning

Pamida Stores Operating Company, LLC

"Marketing Impact and SMW worked with us to create effective shelf management systems for deodorant, vitamins and DVD's.

When we needed a security system for razors, they created it.

Their turn-around times are quick. When there is a rush they come through. They are innovative and competitive."

Mike Angus

Director of Projects

Loblaw Companies Ltd.

"We have been working with Marketing Impact for well over 10 years now and their levels of service, turnaround and quality have always been exceptional. The timelines that we encounter are always challenging, if not unrealistic, but we have never been let down or disappointed. We have also challenged them to come up with solutions for displaying new and different products and their design input has been thoroughly thought out. There is always the right balance between aesthetics, cost and practicality. The team at Marketing Impact is always a pleasure to work with."

Walter Ciferons

Director of Design and Development

Shoppers Drug Mart

"Having worked with Marketing Impact on various projects for over 10 years, we have always greatly enjoyed our experience. In addition to the cutting edge designs and out of the box thinking, their entire team has always been receptive to our needs and provided us with the best quality products and service."

Mark Finkelstein

Retail Sales Director

PharmaSystems Inc.

"Zellers and Home Outfitters have worked with Marketing Impact for several years, and over that time, they have partnered with us to develop many creative, functional and cost effective merchandising and signage programs. They are very innovative, and you can count on their creativity to solve your challenges in-store. In short, I find them to be very customer focused, reliable and cost effective. I would not hesitate to recommend them to my industry colleagues."

John Watson

Director of Construction, Store Planning & Fixtures

Zellers and Home Outfitters Stores

 **marketing** **IMPACT**
LIMITED

*Always
Innovating*

LET US SHOW YOU HOW!

ORGANIZE, DISPLAY, UP-SELL, AND PUSH WITH MARKETING IMPACT'S
INNOVATIVE AND COST EFFECTIVE MERCHANDISING SOLUTIONS.

OVER 150 NEW PRODUCTS!

We are proud to include over 150 new solutions in our product line up. At Marketing Impact we're always innovating new products for all your merchandising and retail needs.

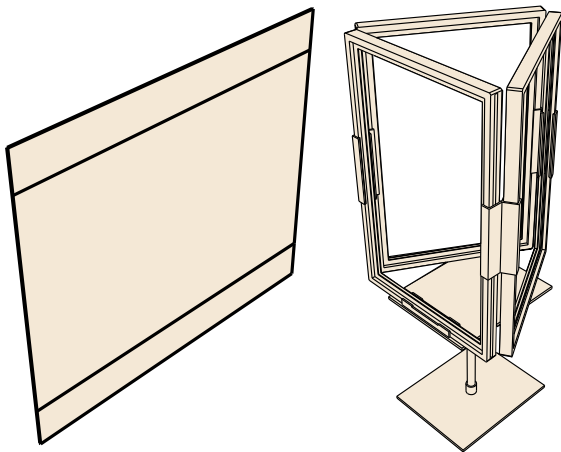

SIGNHOLDER SYSTEMS

WHAT'S NEW

2-Way Sign Grip Clip	Pg. 49
3-Way Copoly Signholder	Pg. 18
3-Way Countertop Signholder	Pg. 18
4-Sided Signholder	Pg. 42
4-Way Frame Connector	Pg. 17
4-Way Frame Kit	Pg. 17
Clear 3-Sided Signholder	Pg. 42
Dual Frame	Pg. 45
Dual Frame Connector	Pg. 45
Front Loading Aluminum Snap Frames	Pg. 16
Greeting Card Divider	Pg. 40
Peg Hook Signholder	Pg. 22
Pivoting Sign Clip	Pg. 47
Reusable Magic Frames	Pg. 16
Sign Riser	Pg. 45
Snap-It Signholder	Pg. 40

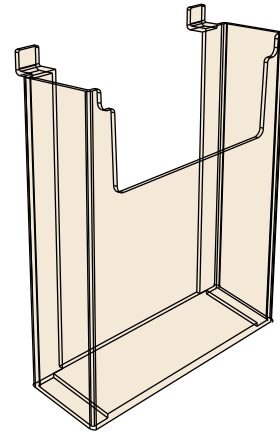

BROCHURE HOLDERS

WHAT'S NEW

Magazine Pocket Holder

Pg. 57

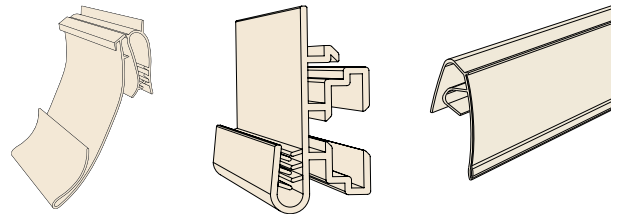

SHELF TICKETING STRIPS

WHAT'S NEW

4" Flip Channel	Pg. 65
Basket Clip	Pg. 69
Dual Frame	Pg. 72
Glass/Wood Label Holder	Pg. 70
Hinged Basket Clip	Pg. 69
SuperGrip™ 1" Flush Signholder	Pg. 69
SuperGrip™ 60 Degree Panel Former	Pg. 71
SuperGrip™ Signholder	Pg. 69
Wire Channel Clip	Pg. 65

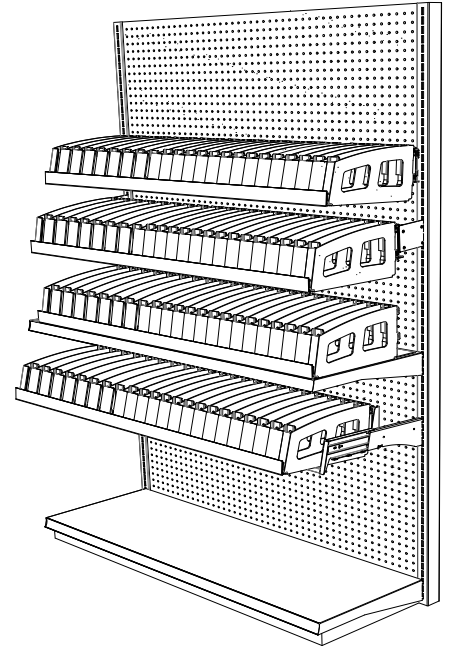
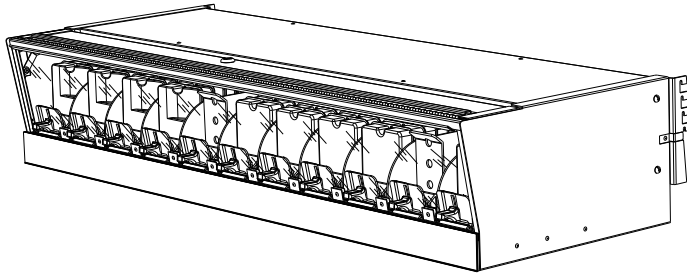
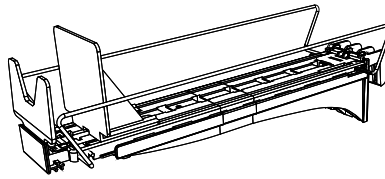
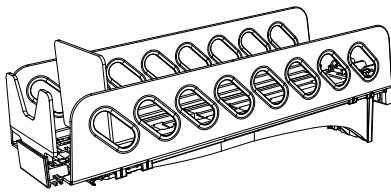

MODULAR MERCHANDISING SYSTEMS

WHAT'S NEW

Adapter Clips (Small & Large)	Pg. 103	Light Duty Extruded Track and Divider	Pg. 101
Adjustable Clip-In Divider	Pg. 77	Medium Duty Extruded Track and Divider	Pg. 101
Adjustable Crossbar	Pg. 94	Metal Deli Meat Shelf	Pg. 95
Adjustable Tray Style Pusher Kit	Pg. 89	Moulded Dividers	Pg. 94
Condiment System	Pg. 100	Pegboard Mount Light Duty Pusher System	Pg. 97
Custom Gravity Wedge	Pg. 103	Pegboard/Slatwall Clear U-Hook	Pg. 80
Drink System	Pg. 100	Pull Out Adjustable Crossbar Mount Light Duty Pusher System	Pg. 97
Extruded Divider	Pg. 102	Pusher Clear Front	Pg. 82, 92
Extruded End Cap	Pg. 102	Pusher Curved Front	Pg. 82, 92
Extruded Gravity Feed	Pg. 98	Shelf Cooler Baffle / Support Bar	Pg. 95
Flip Data Strip	Pg. 97	Shelf Mount Pusher with Adjustable Divider	Pg. 79
Greeting Card Divider	Pg. 78	Shelf Mounted Light Duty Pusher System	Pg. 97
Hanging / Shelf Mounted Pusher System	Pg. 96	Thin Adjustable Clip-In Divider	Pg. 77
Heavy Duty Extruded Track	Pg. 102	Slatwall / Pegboard & Wire Shelf Frame Holder	Pg. 84
Heavy Duty Extruded Track and Divider	Pg. 101	Spice System	Pg. 100
Hook Bar C-Clamp with Label Plate	Pg. 95	Support Bar	Pg. 94
Insert Shelf	Pg. 84	Tall Light Duty Paddle Straight	Pg. 83, 102
Kwickload™ Cooler Baffle	Pg. 95	Tall Light Duty Paddle with Angled Front	Pg. 83, 102
Kwickload™ Crossbar Mount Kit	Pg. 93	Upright Mount Light Duty Pusher System	Pg. 97
Kwickload™ Pivoting Label Holder	Pg. 92	Wire Dividers	Pg. 94
Kwickload™ Shelf Mount Plate	Pg. 93	Wire/Flat Fence Clear U-Hook	Pg. 86
Large Interlocking Pusher Tray	Pg. 79	Custom Gravity Wedge	Pg. 101

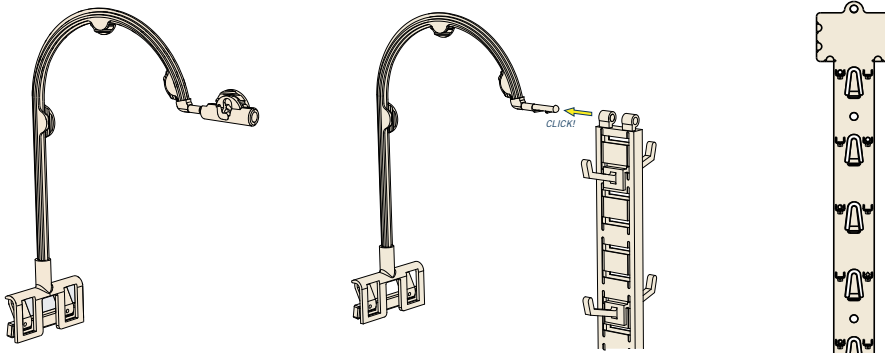

HANGING RETAILERS & DISPLAY COMPONENTS

WHAT'S NEW

3-Way Baffle	Pg. 137
3-Way Wire Carousel	Pg. 137
4-Way Baffle	Pg. 137
4-Way Wire Carousel	Pg. 137
Carry Handle Strap	Pg. 131
Clear Bown with Stem	Pg. 136
Cross Base	Pg. 138
Display Pole	Pg. 138
Double Sided Hanging Retailer Extender	Pg. 118
Giftcard Extender	Pg. 115
Heavy Duty Moulded Strip Retailer	Pg. 118

Large Handle Strap	Pg. 131
Light Duty Handle Strap	Pg. 131
Octagonal Base	Pg. 138
Revolving Clip Strip Display	Pg. 138
Sign Clip Adapter	Pg. 137
Small Handle Strap	Pg. 131
The MAX Counter Spinner	Pg. 117
The MAX Floor Spinner	Pg. 117
Trumpet Base	Pg. 138
Wire Dump Bin	Pg. 138

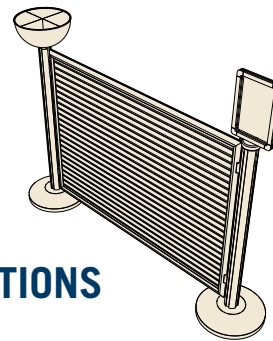
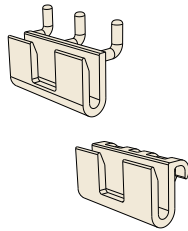
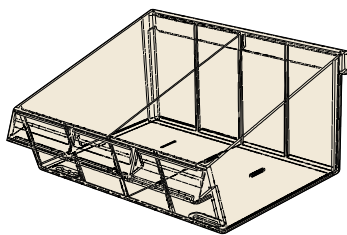

MERCHANDISING SOLUTIONS

WHAT'S NEW

Bowl Divider	Pg. 149
Bowl Divider with Signholder	Pg. 149
Cool-Ads™ Coupon Accessory	Pg. 147
Cool-Ads™ Plastic Handle	Pg. 147
Deskwindo™	Pg. 151
Grippa™ Mushroom Head Suction Cup	Pg. 141
Magazine Pocket Holder	Pg. 149
Merchandising Bowl	Pg. 149
Metal Basket	Pg. 150
Metal Tray	Pg. 150

Multi-Purpose Adjustable Bin Dividers	Pg. 141
Multi-Purpose Adjustable Bins	Pg. 141, 150
Pegboard / Slatwall Clear U-Hook	Pg. 141
Satin Aluminum Hinge Framed Slatwall	Pg. 148
Satin Aluminum Post with Grey Base	Pg. 148
Satin Aluminum Signholder with Swivel Mount	Pg. 149
Skid Fender	Pg. 150
Slatwall / Pegboard Frame Holder	Pg. 150
Cool-Ads™ Sound and Light Module	Pg. 147
Wire / Flat Fence Clear U-Hook	Pg. 141

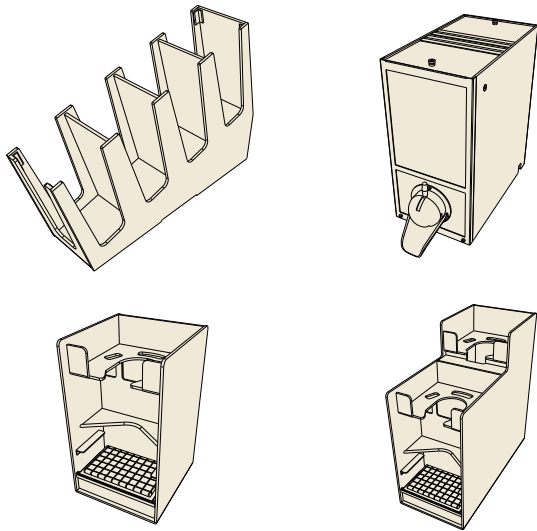

BEVERAGE SYSTEMS WHAT'S NEW

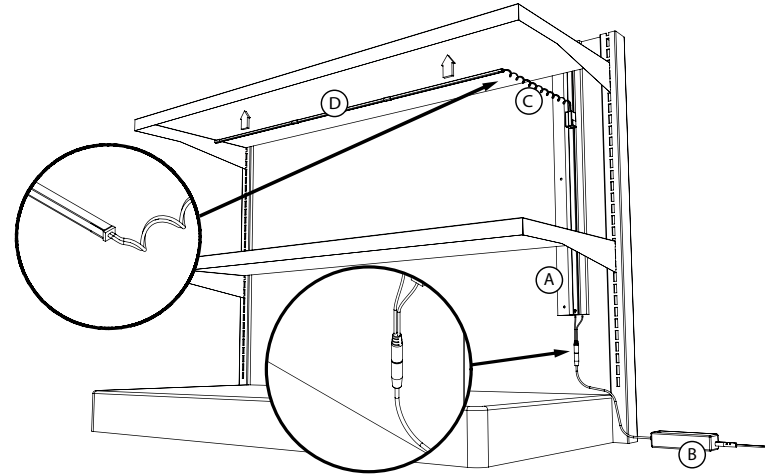

LIGHTING SOLUTIONS WHAT'S NEW

3 Level Lid Holder	Pg. 157
3 Silo Cup/Lid Holder with Stir Stick Caddy	Pg. 157
501 Whole Bean Free Flow Coffee	Pg. 154
700 Series Whole Bean Free Flow Coffee	Pg. 154
Clip-On Hot Beverage Sleeve Holder	Pg. 158
Condiment Tower	Pg. 155
Condiment Tray with Stir Stick Caddy	Pg. 156
Cutlery Tower	Pg. 158
Double Gravity Pot Stand	Pg. 155
Espresso Knock Boxes	Pg. 158
Hot Beverage Sleeve Holder	Pg. 158
Hot Beverage Sleeve Pusher	Pg. 158
Pastry Case	Pg. 158
Second Tier Condiment Tray Add-On	Pg. 156
Short Single Gravity Pot Stand	Pg. 155
Single Gravity Pot Stand	Pg. 155
Single Tier Condiment Tray	Pg. 156
Sloped Cup/Lid Holder	Pg. 157
Stir Stick/Straw Holder Add-On	Pg. 157
Syrup Racks	Pg. 158
Thermal Gravity Pot Beverage Dispenser®	Pg. 155
Two Tier Condiment Tray	Pg. 156

12" Power Feed	Pg. 161
60 Watt LED Plugin Driver	Pg. 162
Coloured LED Ribbon	Pg. 162
Indoor Colour Changing LED Tape	Pg. 162
Indoor LED Pencil Light	Pg. 161
LED Indoor Strip Tape	Pg. 161
Low-Voltage Vertical Power Strip	Pg. 160
Low-Voltage Wire Harness	Pg. 160
Male/Female LED Connector	Pg. 160
Outdoor High Output LED Tape	Pg. 161
Outdoor LED Tape	Pg. 161
Power Supply	Pg. 161
Powerstrip Connector Harness	Pg. 160
Super Slim LED Pencil Light	Pg. 160
Trio Edge Shelf Light	Pg. 162
Universal LED Lit Cornice	Pg. 162
Universal Undershef Light (Compression Fit)	Pg. 162
Wire Splice Extension Kit	Pg. 161

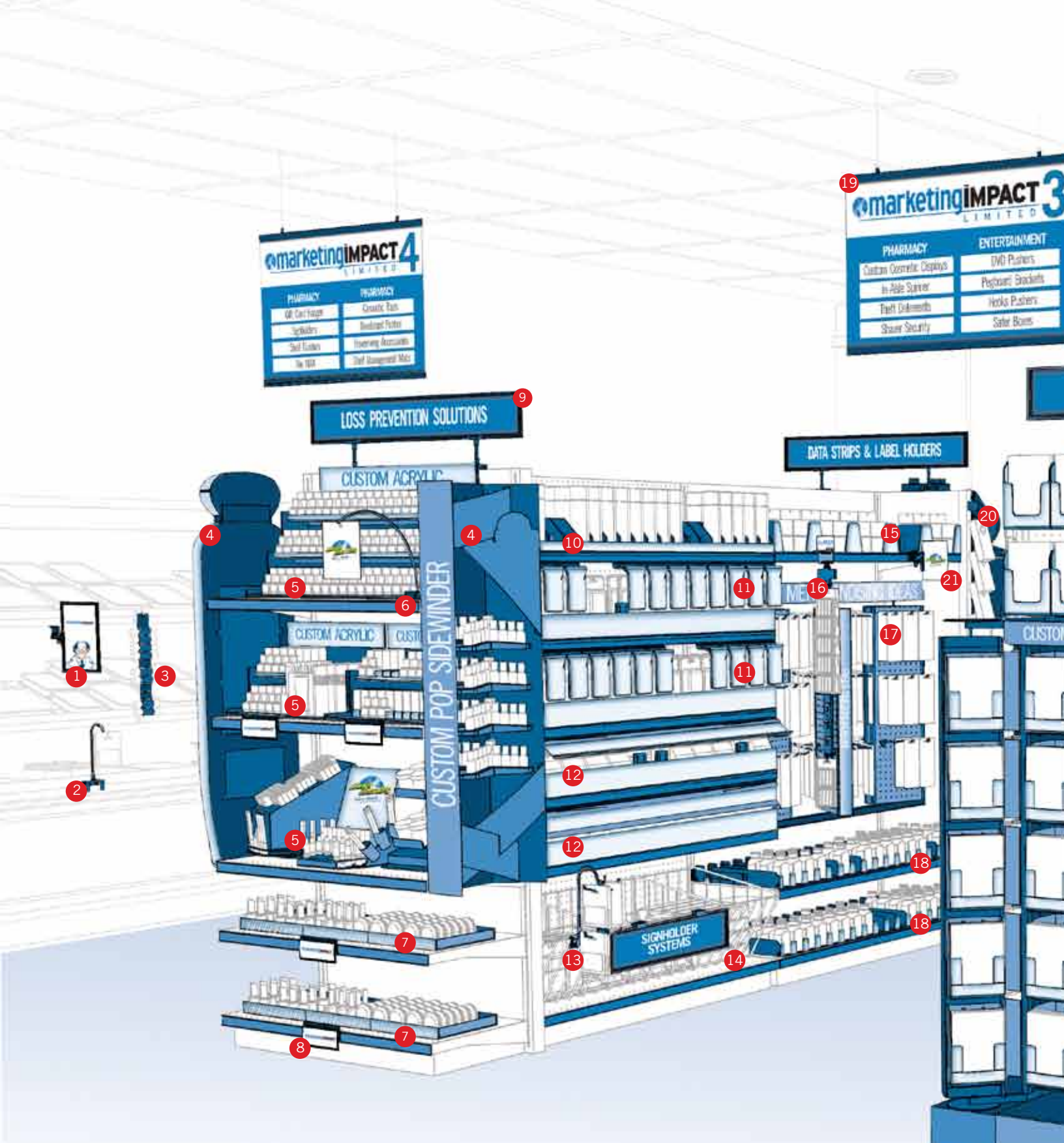

- | | | |
|---|---|---|
| 1 Sign Frame with Self-Centering Under Shelf Mount - p36 | 7 Shelf Management Mats - p80 | 13 The Gift Card Extender - p115 |
| 2 Gift Card Hanger - p19 | 8 Clear Dual Extrusion - p66 | 14 Signholder Frame 5½" x 24" with Wire / Bin Mount - p14, 23 |
| 3 Durable Vinyl Pouch Retailer with S-Hook - p120 | 9 Sign Frame with Two Magnetic Stem Bases, 5½ x 36" - p34 | 15 Snap-In Adjustable T Dividers p78 |
| 4 Custom Cosmetics POP Sidewinder - p164 | 10 Pharmacy Pusher Kit with 4" Adjustable Dividers - p87 | 16 The Max Hanger with Heavy Duty Strip Retailer - p115, 118 |
| 5 Custom Acrylic Cosmetic Displays p168 | 11 Invisi-Shield™ Panel Kit with Shelf Pusher Kit - p111 | 17 Custom In-Aisle Pharmacy Spinner - p164 |
| 6 The Wobbler with Gondola and Shelf Top Mount - p19 | 12 Security Flip Door & Alarm with Shelf Pusher kit - p109 | 18 2" Snap-In Adjustable Dividers with Front Stops - p76 |
| | | 19 Snap Banner Track - p151 |
| | | 20 Heavy Duty Moulded Strip Retailer & S-Hook - p118, 120 |
| | | 21 Self Centering C-Channel Mount with Strip Mount Gripper - p25, 28 |
| | | 22 Custom POP DVD End Cap p164 |

marketingIMPACT 2 LIMITED	
GROCERY	PRODUCE
Bottle Pusher	Del / Cheese Pusher
Candy Pusher	Produce Bin
Fold N Load Pusher	Produce Pusher
T-Dividers	Interlocking Trays

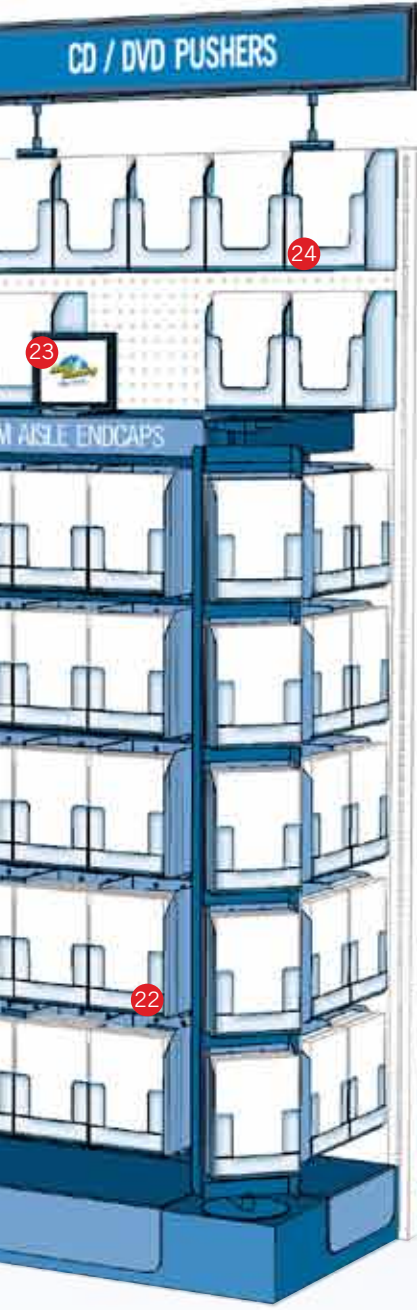

- 23 Sign Frame with Shovel Base 5 1/2" x 7" - p34
- 24 DVD Pusher Box - p85
- 25 Custom Pusher Trays - p79

- 26 Single Hook Snap-on Pusher p84
- 27 Loop Hook Snap-on Pusher p84
- 28 Large Divider - p78

- 29 Sign Frame with Self Centering Under-Shelf Mount - p37
- 30 Fold N Load™ Light Duty Pusher Kit - p87
- 31 Light Duty Pusher Kit with Fold-N Load™ & 3" Fence - p81, 87
- 32 Shelf Mounted Bottle Pusher System - 500ml - p88
- 33 Shelf Mounted Bottle Pusher System - 2L - p88
- 34 Custom POP Candy Sidewinder - p166

- 35 3 Way Pillar Floor Standing Sign - p33
- 36 Beverage Holder - p145
- 37 The Wobbler with Glass Suction Mount - p19
- 38 Durable Vinyl Pouch Strip Retailer with Suction Hook - p120, 134
- 39 Cooler Merchandiser Rack p145
- 40 Merchandiser Rack - 6 - p145

- 1 Small Produce Bin Set - p146
- 2 Sign Frame with Center Stem Base, 7"x11" - p35
- 3 Snap Banner Track - p151
- 4 Produce Pusher Kit - p88
- 5 The Wobbler with Clip-on Stem Base - p19, 21
- 6 Clip-on Spring Signholder - p54
- 7 Deli / Cheese Pusher Kit - p88
- 8 Self-Centering Under Shelf Swivel Mount with Strip Gripper - p28,25
- 9 Interlocking Pusher Trays - p79
- 10 Medium Duty Pushers with 3" Clear Front Fence - p75,81
- 11 Custom POP Candy Sidewinder p166
- 12 Custom POP Chocolate Tray p166
- 13 Wire Dump Bin - p138
- 14 Kwik Load™ Crossbar Pusher System - p90
- 15 Clip-on Spring Signholder - p54



- 16 Snap-In Adjustable Dividers p78
- 17 Double Label Holder- p71
- 18 Sign Frame with Two Magnetic Stem Bases, 5½" x 36" - p34
- 19 The Max with The Extended Max Hanger - p114, 115
- 20 Beverage Holder - p145
- 21 The Max Pocket with Versa Pusher Clip - p116
- 22 Merchandiser Rack - 6 - p145
- 23 Sign Frame with Self Centering Under Shelf Mount, 7"x11" - p36
- 24 Slatwall & Pegboard Adjustable Bracket - p84
- 25 The Max Spinner with The Max Spinner Bracket - p117
- 26 Shelf Extender - p145
- 27 Large Dividers - p78
- 28 Shelf Mounted Bottle Pusher Kit - p88
- 29 Universal Label Holder - p72



- 30 The Max 10" - p114
- 31 DVD / Video Game Pusher Kit p88
- 32 Fort Knox™ Security Box with Hanging Tab - p112
- 33 The Max 30" with The Max Hanger - p114, 115
- 34 Fort Knox™ Security Box - p112
- 35 Gift Card Hanger - p19
- 36 Single Hook Snap-On Pusher p84

- 37 Loop Hook Snap-On Pusher - p84
- 38 Heavy Duty Pusher with 3" Clear Front Fence - p75, 81
- 39 Custom POP Battery Display - p167
- 40 The Max 30" with Universal Bracket and The Max Card Holder - p114, 116
- 41 Cosmetic Trays - p80
- 42 Signholder Frame with Two Channel Clip Mounts - p14, 23
- 43 Pegboard / Slatwall Extension Mount with Strip Mount Card Holder - p21, 25

- 44 Custom POP Cosmetics Hanging Pegboard Display - p167
- 45 Multi-functional Adjustable Bins p141
- 46 Custom POP Floor Display - p167
- 47 Multi Use Medium Duty Pusher with Clear Front - p75, 92
- 48 Deodorant Pusher Kit - p87
- 49 Small Dividers - p78
- 50 Fold N Load™ Light Duty Pusher Kit for Pharmacy Products - p87

- 51 Multi Use Heavy Duty Pusher with Clear Front - p75, 92
- 52 4" Snap-In Adjustable Divider with Front Stops - p77
- 53 Custom POP Cosmetics Sidewinder p166
- 54 The Wobbler with Glass Suction Mount - p19
- 55 Cooler Merchandiser Rack - p145



SIGNHOLDER SYSTEMS

The most versatile systems of their kind in North America, with solutions for any signage need.



SIGNHOLDER FRAMES

Imperial and metric frames are moulded in high-impact styrene with mitered edges. Use horizontally or vertically. Standard colours are white, black, red and beige.

* Custom colours available. Minimum quantities apply.

US Patent #5,442,873 / Canadian Patent #2,114,091

Colours Available

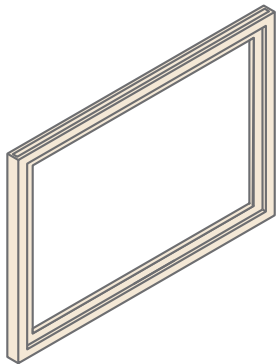

Imperial Frames

3½" x 5½"	SH0355
3¼" x 8¼"	SH0358
5" x 6"	SH0056
5½" x 7"	SH0557
7" x 11"	SH0711
8½" x 11"	SH0085
11" x 14"	SH0114
5½" x 24"	SHOMMF5524
5½" x 36"	SHOMMF5536

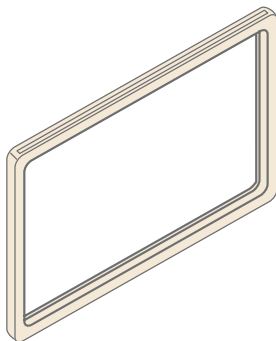

Metric Frames

220 mm x 185 mm	SHOMA1
279 mm x 219 mm	SHOMA4
210 mm x 148 mm	SHOMA5
148 mm x 105 mm	SHOMA6

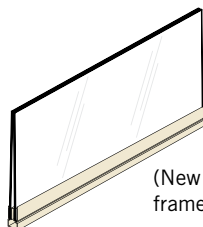

(New and improved frame base)

Frameless Signholder

Compatible with all mounting accessories. Can be used horizontally or vertically. Open on three sides for convenience. Frame base is available in white, black, red and beige.

US Patent #5625969

5½"W x 3½"H	CLFRALAN355
7"W x 5½"H	CLFRALAN557
11"W x 7"H	CLFRALAN711
11"W x 8½"H	CLFRALAN851
14"W x 11"H	CLFRALAN114
3½"W x 5½"H	CLFRAPOR355
5½"W x 7"H	CLFRAPOR557
7"W x 11"H	CLFRAPOR711
8½"W x 11"H	CLFRAPOR851
11"W x 14"H	CLFRAPOR114

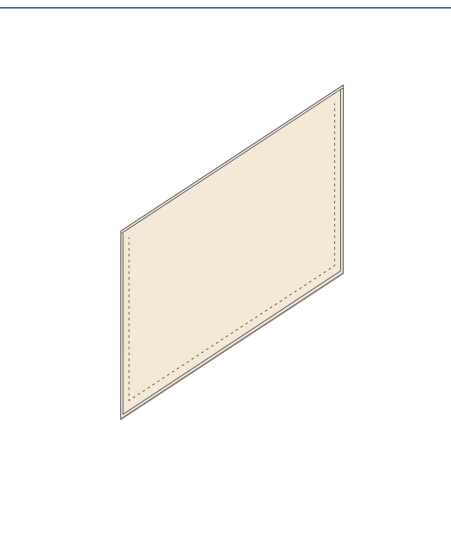

Clear Vinyl Pocket Signholders

Clear, rigid PVC pockets hold and protect standard size signs. Opening on one side. Can be used with Strip Mount or Multi-Use Coil Mount to attach to most shelves.

3-1/2" x 2-1/4"	DSP35225
3-1/2" x 5"	DSP355
4" x 6"	DSP46
5-1/2" x 7"	DSP557
8-1/2" x 3-1/2"	DSP8535
8-1/2" x 5-1/2"	DSP8555
11" x 7"	DSP117
8-1/2" x 11"	DSP8511
22" x 28"	DSP2228

* Custom colours available. Minimum quantities apply.

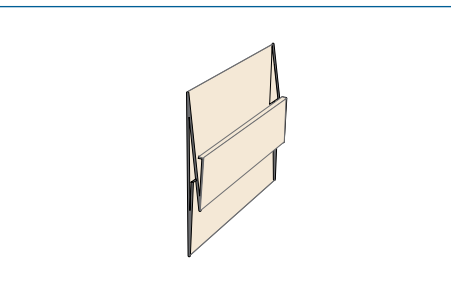

Clear Vinyl C-Channel Sign Holders

5"x 3½"	CCHANNELHLDR5X3
5"x 7"	CCHANNELHLDR5X7
7"x 11"	CCHANNELHLDR711

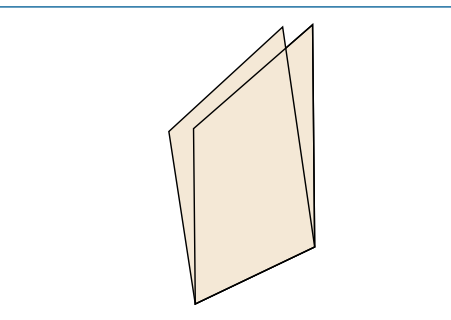

Clear Vinyl Foldover Sign Holders

3½"x 5½"	FOLDOVER3555
5½"x 7"	FOLDOVER557
7"x 11"	FOLDOVER711
8½"x 11"	FOLDOVER8511
11"x 14"	FOLDOVER114

ALUMINUM SNAP FRAMES

Available in various colours and sizes, this sign is built to last. It's simple design allows for easy graphic interchangeability. These snap frames are front loading, easy to hang, and sure to make any store message or advertisement stand out.

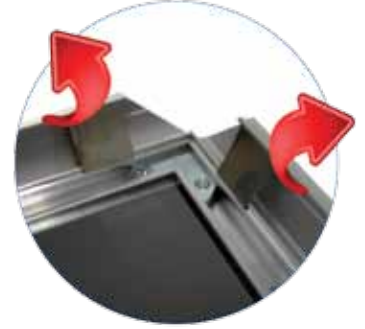

NEW

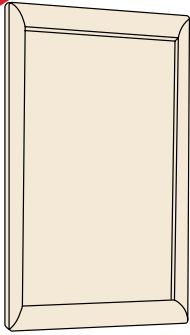

Front Loading Aluminum Snap Frame

7"x 11"	ALUSNAP0711
8½"x 11"	ALUSNAP8511
11"x 14"	ALUSNAP1114
11"x 17"	ALUSNAP1117
18"x 24"	ALUSNAP1824
22"x 28"	ALUSNAP2228

REUSABLE MAGIC FRAMES

A quick, clean and easy way to hang signage on any smooth flat surface. A special molecular gel allows repeated use while providing a secure attachment to walls or counters. No residual adhesive left behind!

Features and Benefits:

Eliminate messy tape from your windows. Magic frame stays up in hot or cold weather, unlike suction cups.

Display 2 sided signs.

Durable Clear plastic with white border or black.

Quickly display signs on:

- Cooler Doors
- Windows
- Deli Cases
- Any smooth flat surface



NEW

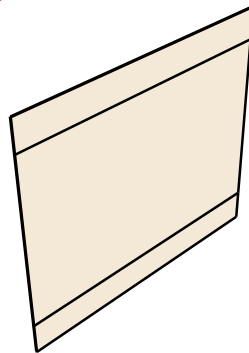

Reusable Magic Frame

3-1/2"W x 5-1/2"H	RSH03555
8-1/2"W x 5-1/2"H	RSH08555
7"W x 11"H	RSH00711
8-1/2"W x 11"H	RSH08511
17"W x 11"H	RSH01711
22"W x 28"H	RSH02228

* Please specify border colour when ordering.



MODULAR SIGNHOLDER SYSTEMS

MIX AND MATCH TO SUIT YOUR NEEDS!

In-store advertising is simple and effective with our full line of signholders and accessories. For shelves, slatwall, pegboard, glass, walls, or right on your merchandise, we have a signage solution for your specific requirements. Manufactured from high-impact styrene, they're built to last. Standard colours are white, black, red, and beige. Custom colours available.

HOW DOES IT WORK?

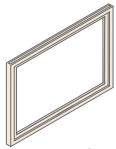

Choose the frame that's right for you.

We offer a variety of typical sizes, both imperial and metric. Our patented locking system keeps the sign securely in place, allowing you to display the frame vertically or horizontally.

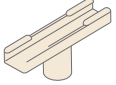

Add bases and accessories for total versatility.

Our selection of frames, bases and accessories gives you limitless solutions to all your signage challenges.

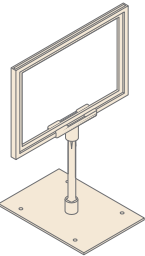
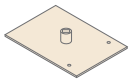

The result is a signage solution for your specific needs.

We have what you need to display your signs any way you require. Call us for innovative ideas.



Colours Available



NEW

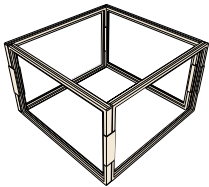

4-Way Frame Kit

- Kit Includes**
 4 – 11" W X 7" H Frames
 4 – Frame Connectors
 4 – Clear Vinyl Foldovers

FOURWAY117

* Please specify colours when placing order.

NEW

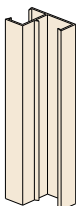

4-Way Frame Connector

Moulded in PVC in standard signholder colours.

3" Long

SHE0311



3-Way Signholder Kit

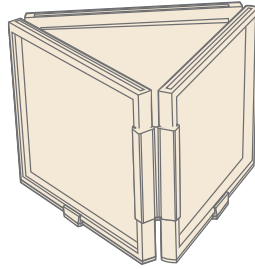

3½" x 5"	THREEWAYKIT355
5½" x 7"	THREEWAYKIT557
7" x 11"	THREEWAYKIT711
8½" x 11"	THREEWAYKIT851
11" x 14"	THREEWAYKIT114

Available in black, red or white. Custom colours available. Minimum quantities apply.

- Standard Kit Includes:**
 3 - Frames
 3 - Frame Connectors
 3 - Clear Vinyl Foldovers



Before



After

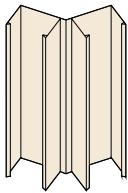

3-Way Frame Connector

Moulded in PVC in standard signholder colours.

SHE2498

NEW

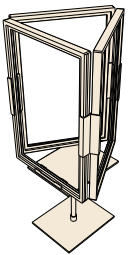

3-Way Counter Top Signholder

- Kit Includes**
 3 - 7" W X 11" H Frames
 3 - Frame Connectors (SHE2498)
 2 - Center Bases
 1 - Stem (6")

CTS0711-06

* Please specify colours when placing order.

NEW

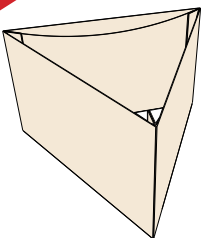

3-Way Copoly Signholder

Top loading, clear triangular signholder for signage measuring 11"W x 7"H

11"W x 7"H

TRI1107

*Custom sizes available. Minimum quantities apply.

SHOPPING CART / WALL MOUNT SIGNHOLDER

Weather resistant sign holder mounts to shopping cart or wall to display store messaging or advertising. Easy to install and change signage, no tools required.

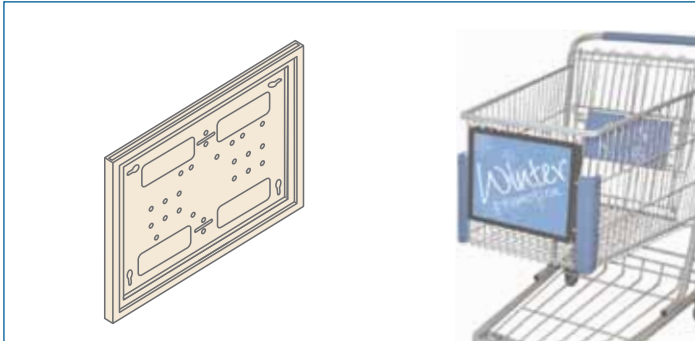

Shopping Cart/Wall Mount Sign Holder

Standard Kit Includes:

- 2 - Frames
- 2 - Clear Vinyl Foldovers
- 2 - Permanent Locking Straps

7"x 11"	CARTKIT711
8½"x 11"	CARTKIT8511

* Available in black, red, silver or white.
 ** Custom colours available. Minimum quantities apply.

GIFT CARD HANGER

The Gift Card Hanger lets product hang directly from the hook for an interesting free-floating effect. It is ideal for gift cards or cross merchandising. The unique base can mount to most wire and flat fences. It is molded in polycarbonate and is extremely durable and economic.



Gift Card Hanger

Fits most wire and flat fences. Moulded in polycarbonate. Available in Clear, White and Black.

	GIFTHOOK
--	----------

*Custom colours available. Standard colours are clear, black, and white. (Minimum Quantities Apply)

THE WOBBLER SIGN SYSTEM



The Wobler

The Wobler is one of the most versatile signholders. Signs hang directly from the Wobler's hook for an interesting free-floating effect. The curved stem can hang signs above and in front of product sitting on shelves or hanging on pegboard or wire.

Includes mount, 15" stem, connector and Curved Wobler moulded in polycarbonate.

Standard colours are clear, black and white. Custom colours available.

(*Please specify base style when placing order.)

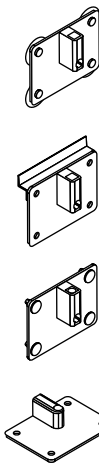

WOBBLER — GLASS

Wobler sold with 4 suction cups (unassembled) which allows signage to be displayed on a flat surface.

WOBBLER — SLATWALL

Wobler can be easily mounted onto slatwall to display signage.

WOBBLER — PEGBOARD

Wobler sold with 4 push pins (unassembled) which allows signage to be displayed from pegboard.

WOBBLER — GONDOLA and SHELF TOP

Wobler sold with base and curved stem and can be used on a gondola or shelf top.

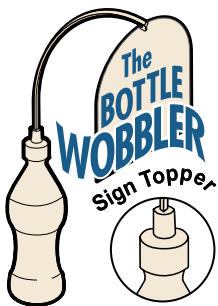

Bottle Top Holders

Works with signholders and wobblers.

Fits 1" Bottle Tops	BOTTLETOP01
Fits 1¼" Bottle Tops	BOTTLETOP02



MOUNTING ACCESSORIES & BASES

Easily attach signholder frames to standard and custom fixtures with our extensive range of accessories and bases. Standard colours are white, black, red and beige to coordinate with all of our signholder frames.

*Custom colours available. Minimum quantities apply.



Stem

Available in seven standard lengths.

2" / 51mm	SHA020
4" / 101mm	SHA003
6" / 152mm	SHA005
8" / 203mm	SHA004
10" / 254mm	SHA001
12" / 304mm	SHA002
15" / 381mm	SHA015

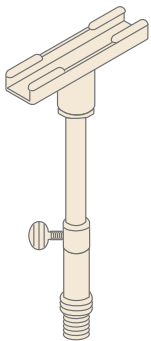

Telescopic Pole Mount

Chrome tube construction attaches to any base or standard fixture.
Stem mount (SHA010) sold separately.

12" - 24"	SHB018-SHORT
15" - 30"	SHB018
24" - 48"	SHB020
36" - 72"	SHB019

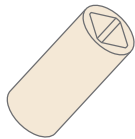

Stem Connector

Connects two stems for extra length.

	SHA006
--	--------

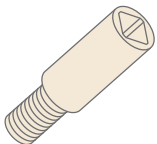

Threaded Stem Adapter

Connects a stem to your existing threaded fixture.

	SHA008
--	--------

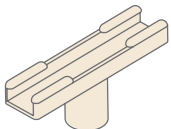

Stem Mount

Connects a frame to a stem. Moulded in K-Resin.

	SHA010
--	--------

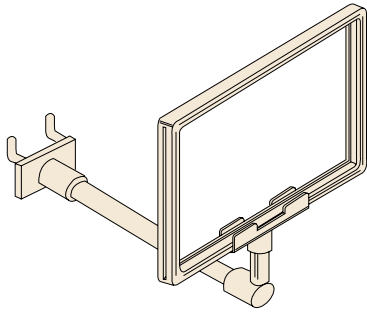

Shown with a 4" Stem

Sign Frame with Pegboard Extension Mount

*Also available with 2", 6", 8", 10", and 12" stem.

*Please specify stem length and kit colour when ordering.

3½" x 5½"	PS158-355
5½" x 7"	PS158-557
5" x 6"	PS158-056
7" x 11"	PS158-711
8½" x 11"	PS158-085
11" x 14"	PS158-114

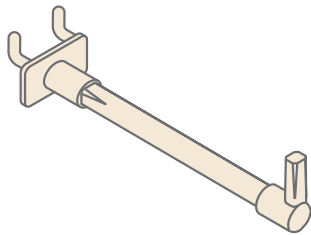

Pegboard / Slatwall Extension Mount

Available in seven standard lengths.

2" Stem	SHA102
4" Stem	SHA104
6" Stem	SHA106
8" Stem	SHA108
10" Stem	SHA110
12" Stem	SHA112
15" Stem	SHA115

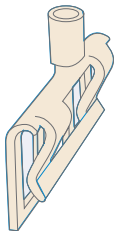

Clip-On Stem Base for Wire Grid / Basket Frame

Mounts to wire, and holds a variety of our signholders including the Wobbler.

	SHB131
--	--------

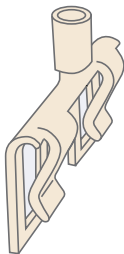

Clip-On Stem Base

Mounts to a flat fence and holds a variety of our signholders including the Wobbler.

	SHB130
--	--------

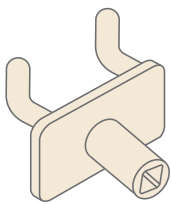

Pegboard / Slatwall Mount

Fits flush to standard pegboard and slatwall.

Fits 1/8" Pegboard	SHA021A
Fits 1/4" Pegboard	SHA021

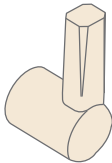

90° Elbow

Connects stem to frame at a 90° angle.

SHA011

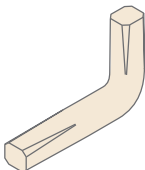

Male-Male Stem, 90°

For various signage applications.

SHA048

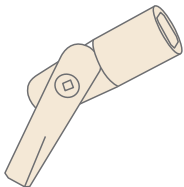

Pivoting Stem Connector

Allows a frame to pivot up to 90° so the sign can be read from above or below.

SHA049

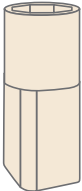

Stem Mount Reducer

Makes a standard 1/2" fixture compatible with our stems.

SHA050

NEW

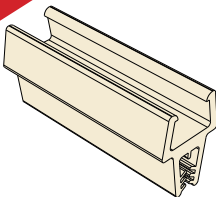

Peg Hook Signholder

Mounts onto the scan plate of a peg hook, or flat fence of a display

SHF0526



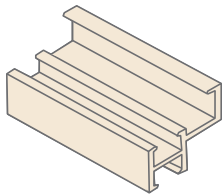

Slatwall Mount

For most slatwall installations. Molded in clear PVC.

Pack of 25

SHA030

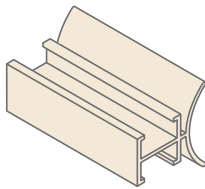

Channel Clip Mount

For use with most 1-1/4" price channels. Molded in clear PVC.

Pack of 25

SHA017

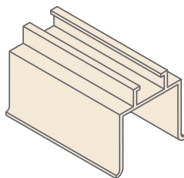

Saddle Clip Mount

For racks, gondolas and other fixtures. Molded in clear PVC. (Pack of 25)

1" wide

SHA012

1/2" wide

SHA013

1-1/2" wide

SHA1502

1-3/4" wide

SHA1752

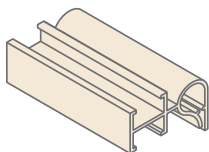

Wire / Bin Mount

Clips your sign to a wire bin or rack.

SHA016

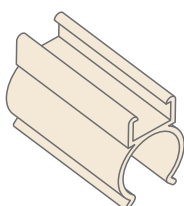

Tube-Clip Mount

For 3/4" to 1" tubes. Moulded in clear PVC. (Sold in Packs of 25)

1" diameter

SHA014CLEAR

3/4" diameter

SHA014CLEAR-SM

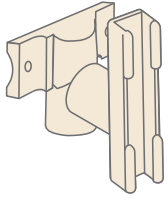

Self-Centering Pegboard / Slatwall Mount

Attaches a frame to a flat or solid surface. Mounting hardware available.

SHA035

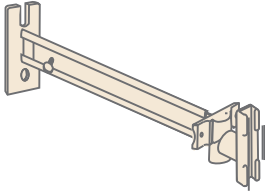

Self-Centering Mount on Expandable Bracket

Mounts to standard shelf uprights, extending sign frames beyond shelves and product. Extends 12" to 23" long.

SHA036

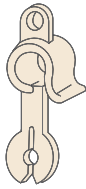

Wire Fence Clip

Clips your sign to a wire bin or rack.

(Requires Frame Mount **SHA041**)

SHA040

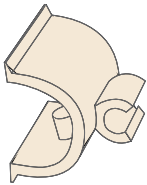

C-Channel Pivoting Connector

Connects your sign directly to a C-Channel.

(Requires Frame Mount **SHA041**)

SHA042

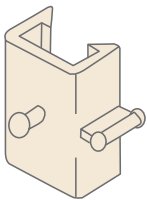

Frame Mount

For use with Wire Fence Clip (SHA024) or C-Channel Pivoting Connector (SHA042)

SHA041



Wire Fence Clip
SHA040

with Frame Mount
SHA041

C-Channel Pivoting
Connector
SHA042

with Frame Mount
SHA041

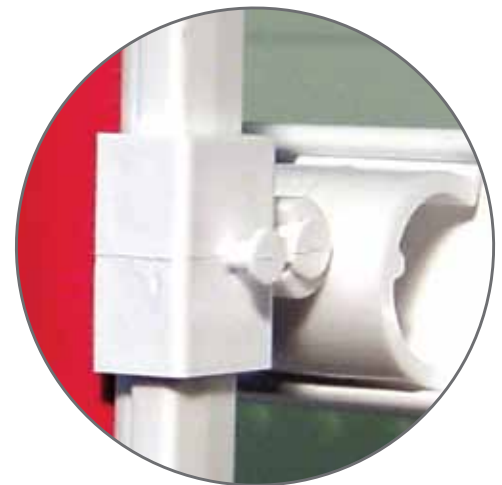



HOW DOES IT WORK?

The Strip Mount is one of our most versatile signholders. Grips card stock (10 pt. – 30 pt. thickness) or a Pocket Signholder simply and easily. Makes a great aisle marker when used with one of our Self-Centering Mounts.

Use with any of our mounting accessories and bases and your signage possibilities are almost limitless! Makes a great gondola topper too.

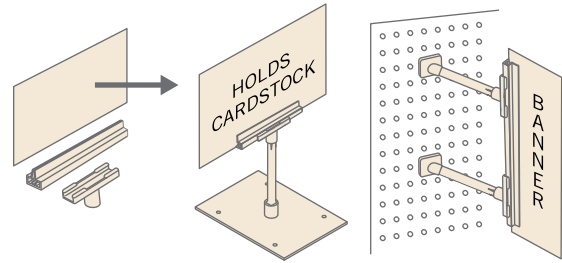

Strip Mount Card Holder
SHE2101

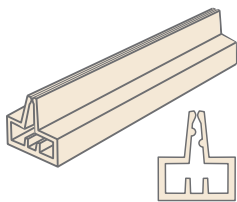

Strip Mount Card Holder

Compatible with our modular signholder system. Available in pieces 1" to 48" long.

SHE2101

*Available in clear and black.

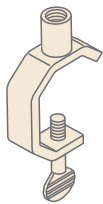

Universal Mount

For mounting to square and round tubing from 1" to 1-1/2". Solid steel with chrome finish.

SHA025

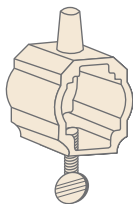

Universal Hang-Rod Clamp

Perfect for apparel and rack signing. Fits square, round and rectangular rods. (Clear plastic)

1 1/2" x 2-13/16" x 1"

SHA026

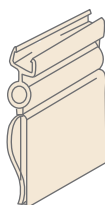

Carton/Basket Clip

For wire rack, bins, cartons, upright dividers, etc. Pivots to any angle. Moulded in clear PVC.

SHB038

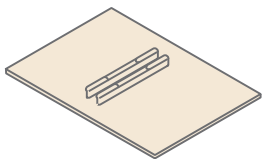

Flat Base

For tables, counters, shelves, and other flat surfaces.

SHB001

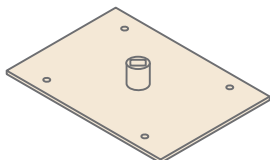

Center Stem Base

For tables, counters, shelves, and other flat surfaces.

SHB002

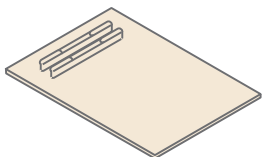

Flat Shovel Base

For end caps and bulk merchandise displays.

SHB005

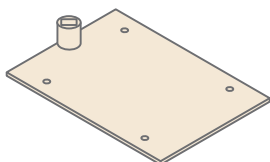

Single Stem Shovel Base

For stem signage on end caps and bulk displays. Pre-drilled holes in corners.

SHB006

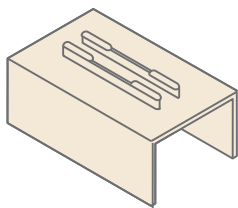

Gondola Center Flat Base

Custom formed to fit any size gondola top. Please provide dimensions when placing order.

SHB012

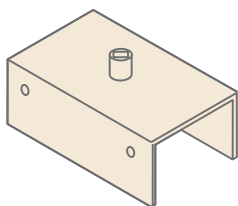

Gondola Center Stem Base

For use with stem signage on gondola tops. Custom formed to fit any size. Please provide dimensions when placing order.

SHB014





Magnetic Stem Base
SHB011



Carton / Basket Clip
SHB038

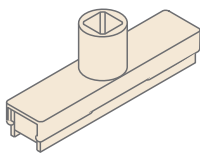

Magnetic Stem Base

Strong magnetic grip for use with metal shelving, racks, and cabinets. Match the colour to the frame.

SHB011

*Available in clear and standard colours.

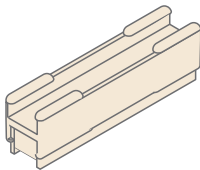

Parallel Magnetic Base

Strong magnetic grip for use with metal shelving, racks, and cabinets. Match the colour to the frame.

SHA027

*Available in clear and standard colours.

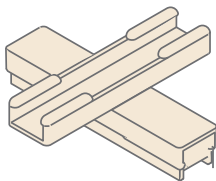

Magnetic Base-Cross

Strong magnetic grip for use with metal shelving, racks, and cabinets. Match the colour to the frame.

SHB028

*Available in clear and standard colours.

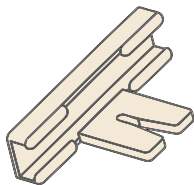

Wall Mount Clip

Easily attaches frames on flat surfaces.

SHA022

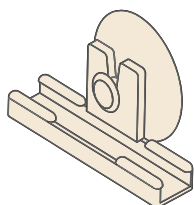

Suction Cup Mount

Mounts on glass and smooth surfaces.

SHA024

Shelf Top Centering Swivel Mount

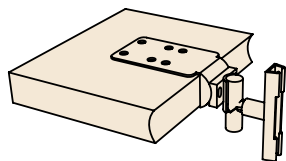

Attaches to most shelf edges.

SHA032

Self-Centering C-Channel Mount

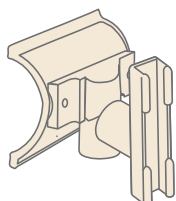

Attaches a frame to a front c-channel.

SHA033

Self-Centering Under Shelf Swivel Mount

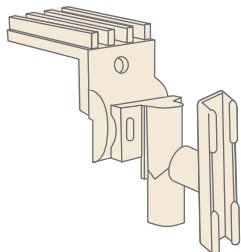

Attaches under the shelf and holds frame perpendicular to shelf edge.

SHA034



Metal Self-Centering Mount

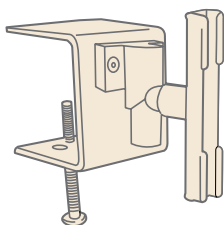

Easily attaches to any shelf and holds signage and self-centering.

SHA037

Custom colours available upon request.



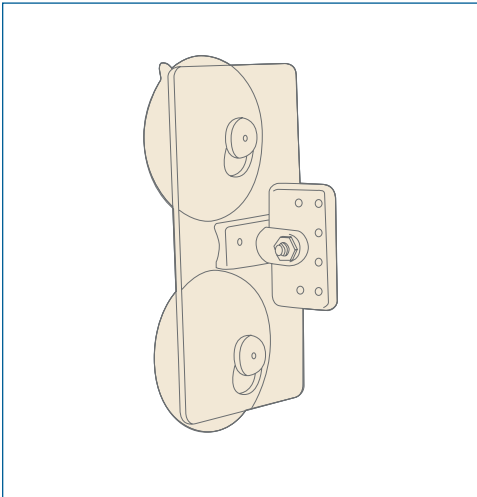

Suction Cup Locking Sign Clip

Affixes to glass or smooth surfaces to display signage. The clip holds signs securely in place.

SHC220

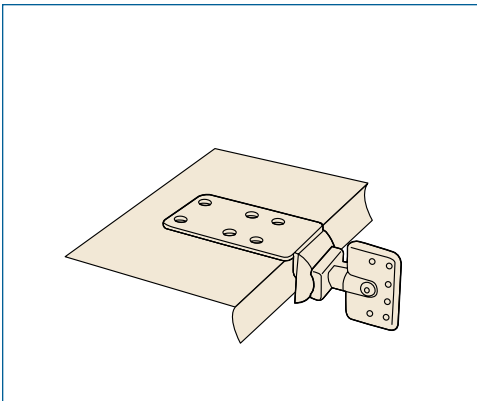

Shelf Locking Sign Clip

Attaches above or below a shelf to display signage. The clip holds sign securely in place.

SHC210

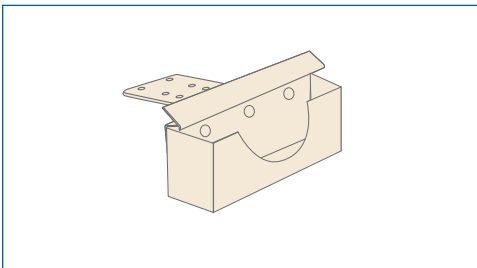

Shelf Bin Holder

Attaches under or above a shelf to hold a bin. The clip holds the bin securely in place.

ACCSH0010

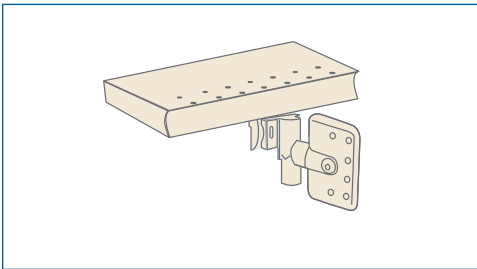

Shelf Spring Sign Clip

Attaches above or below a shelf to display signage. The clip holds sign securely in place and will spring back in place if bumped.

SHC212

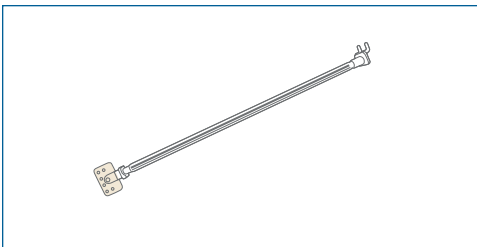

Pegboard Sign Clip

Attaches to pegboard. The clip holds signs securely in place in front of your product.

SHC200-15

IN-STORE ADVERTISING CLIPS

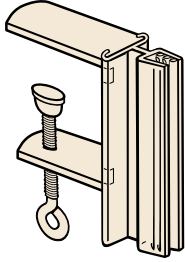

Aisle Signholder with C-Clamp

Add flag aisle signage up to 1-½" thick for square edge shelves or other fixtures. Holds signage up to .100" thick. Sign holder is 3" long.

SHC008SM

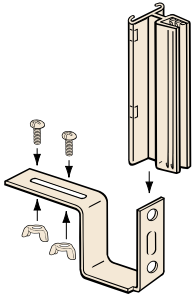

Under-Shelf Mount Signholder

Fits most perforated shelves using bolts and wing nuts which are included. .100" capacity, 3" long, beige metal with clear PVC.

SHA091BEIGECLR

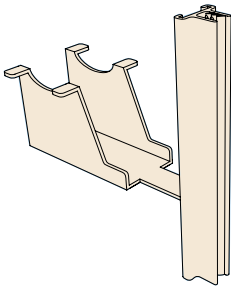

Under-Shelf Mount SuperGrip® Signholder

Spring steel tabs fit most perforated shelves. Holds signs up to 0.100" thick. Use two holders to support blade signs from shelf to shelf.

SHA039

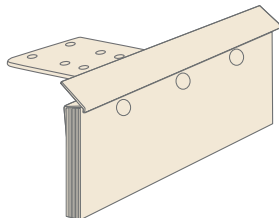

Coupon Holder

Attaches under or above shelf to display coupon books.

ACCSH0020

COIL MOUNTS

THE EASIEST WAY TO ATTACH SIGNAGE TO ANY SHELF!

Moulded in clear polycarbonate. Custom colours available.

*Minimum quantities apply.



Spring Coil with Card Clip | SHA061

HOW DOES IT WORK?

Coil Mounts

When it comes to displaying in-store signage, coil mounts give you unparalleled flexibility. The coil stretches to accommodate shelves up to several inches thick. Reuse it as often as needed. It won't scratch, so it's perfect for wood and delicate surfaces.



- A. Spring Coil with Card Clip
- B. Spring Coil with Extrusion Adapter
- C. Great Flexibility

A

B

C

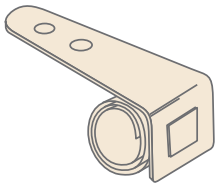

Clear Spring Coil

Holds labels, coupons and Pocket Signholder. Available with or without double sided tape. Moulded in durable, clear polycarbonate.

SHA060

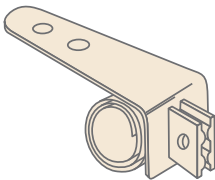

Spring Coil with Card Clip

Holds small signs and cards (10 pt. – 30pt. thickness). Moulded in durable, clear polycarbonate.

SHA061

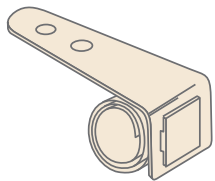

Spring Coil with Extrusion Adapter

Mates with a special extruded signholder so signs are easily inserted and removed. Signholders are made to your custom specifications. Moulded in durable, clear polycarbonate.

SHA062

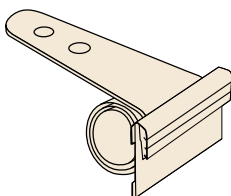

Spring Coil Mount with Griper Applied

Holds paper or plastic signs. Moulded in durable, clear polycarbonate.

SHA064

FLOOR STANDING SIGNHOLDERS

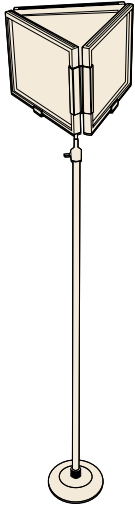

3-Way Floor Standing Signholder

DIMENSIONS

Graphic Area: Varies depending on frame size.
Please see sizes below.

Base: 6" Chrome Base

Adjustable Telescopic Pole: 24"H - 48"H

Frames available in beige, black, red and white.

3-1/2"x 5"	FSD035
5-1/2"x 7"	FSD036
7"x 11"	FSD025
8-12"x 11"	FSD032
11"x 14"	FSD034

*Please specify frame colour when placing order.

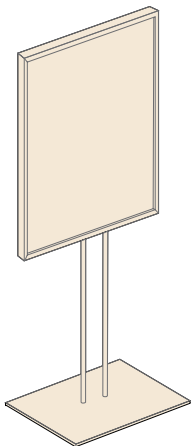

Standing Bulletin Sign with Flat Base

DIMENSIONS

Graphic Area: 22"W x 28"H

Overall Height: 60"

Chrome	FSD020
Black	FSD020BK

*Please specify frame colour when placing order.

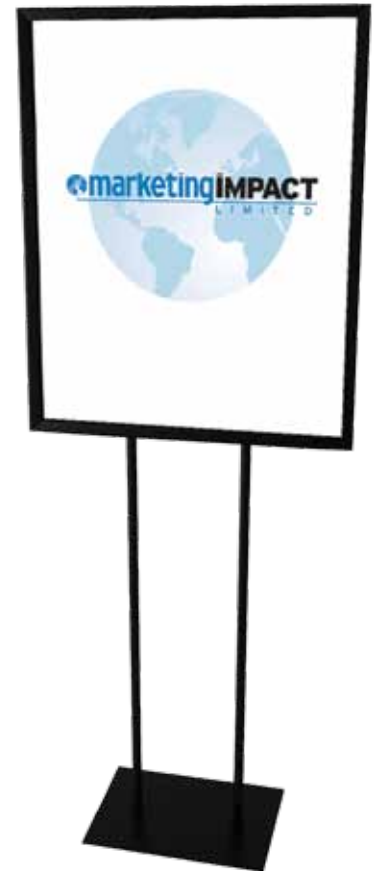



Standing Bulletin Sign with Trumpet Base

DIMENSIONS

Graphic Area: 22"W x 28"H **Base:** 15" Trumpet Base **Overall Height:** 60"

Chrome	FSD020TRUMPET
Black	FSD020TRUMPETBK

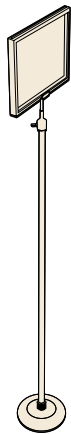

Floor Standing Signholder

DIMENSIONS

Graphic Area: Varies depending on frame size. Please see sizes below.

Base: 6" Chrome Base **Adjustable Telescopic Pole:** 24"H - 48"H

3-1/2"x 5-1/2"	FSD040
3-1/4"x 8-1/4"	FSD041
5"x 6"	FSD042
5-1/2"x 7"	FSD043
7"x 11"	FSD026
8-1/2"x 11"	FSD044
11"x 14"	FSD045

*Frames available in beige, black, red and white.

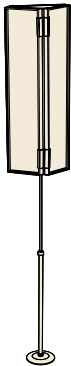

3-Way Pillar Floor Standing Sign

DIMENSIONS

Graphic Area: Varies depending on frame size. Please see sizes below

Base: 8" Chrome Base **Adjustable Telescopic Pole:** 36"H - 72"H

5-1/2"W x 24"H	FSD029
5-1/2"W x 36"H	FSD030

*Frames available in beige, black, red and white.

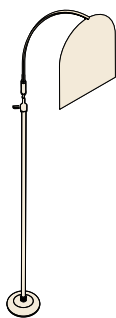

Wobler Floor Standing Signholder

DIMENSIONS

Base: 6" Chrome Base **Adjustable Telescopic Pole:** 24"H - 48"H

Black Stem	FSD027BK
Clear Stem	FSD027CL
Red Stem	FSD027RD
White Stem	FSD027WT

POPULAR SIGNHOLDER KITS

These signholder kits are some of our most commonly requested configurations.

Kits are based on 4" stem lengths where applicable. (*Please specify colour and stem length where applicable when ordering.)



Sign Frame with Adjustable Telescopic Pole & Center Stem Base

DIMENSIONS

Graphic Area: Varies depending on frame size.
Please see sizes below.

Base: Stem Mount (Included)

Adjustable Telescopic Pole: 12"H - 24

3-1/2"x 5-1/2"	PS172-355
5-1/2"x 7"	PS172-557
5"x 6"	PS172-056
7"x 11"	PS172-711
8-1/2"x 11"	PS172-085
11"x 14"	PS172-114

*Frames available in beige, black, red and white.
**Also Available with 2", 6", 8", 10" and 12" Stem.

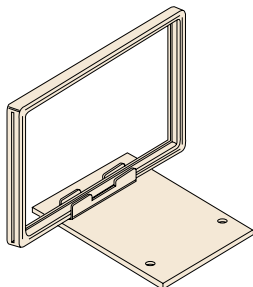

Sign Frame with Shovel Base

3-1/2"x 5-1/2"	PS001-355
5-1/2"x 7"	PS001-557
5"x 6"	PS001-056
7"x 11"	PS001-711
8-1/2"x 11"	PS001-085
11"x 14"	PS001-114

*Frames available in beige, black, red and white.

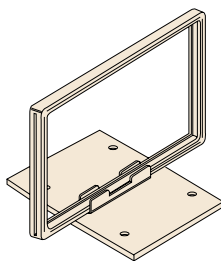

Sign Frame with Flat Base

3-1/2"x 5-1/2"	PS002-355
5-1/2"x 7"	PS003-557
5"x 6"	PS004-056
7"x 11"	PS005-711
8-1/2"x 11"	PS006-085
11"x 14"	PS007-114

*Frames available in beige, black, red and white

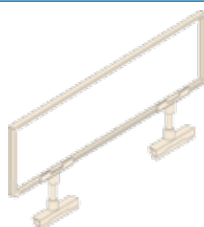

Sign Frame with Two Magnetic Stem Bases (Includes Stem Mount)

5-1/2"x 24"	PS176-524
5-1/2"x 36"	PS176-536

*Frames available in black and white.

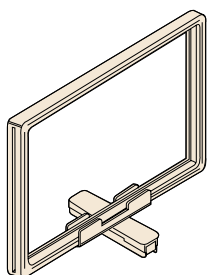

Sign Frame with Magnetic Base

3-1/2"x 5-1/2"	PS115-355
5-1/2"x 7"	PS116-557
5"x 6"	PS117-056
7"x 11"	PS118-711
8-1/2"x 11"	PS119-085
11"x 14"	PS120-114

*Frames available in beige, black, red and white.

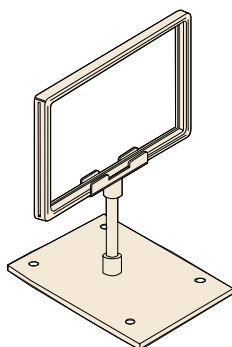

Sign Frame with Centre Stem Base (Includes Stem Mount)

3-1/2"x 5-1/2"	PS004-355
5-1/2"x 7"	PS004-557
5"x 6"	PS004-056
7"x 11"	PS004-711
8-1/2"x 11"	PS004-085
11"x 14"	PS004-114

*Frames available in beige, black, red and white. Also available with 2", 6", 8", 10" and 12" stem.
**Please specify stem length and kit colour when ordering.

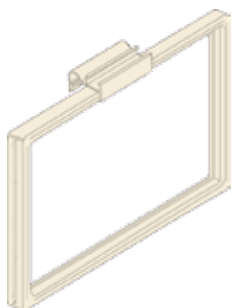

Sign Frame with Wire Bin Mount

3-1/2"x 5-1/2"	PS127-355
5-1/2"x 7"	PS128-557
5"x 6"	PS129-056
7"x 11"	PS130-711
8-1/2"x 11"	PS131-085
11"x 14"	PS132-114

*Frames available in beige, black, red and white.

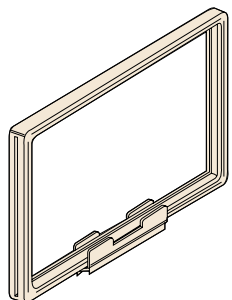

Sign Frame with Parallel Magnetic Stem Base

3-1/2"x 5-1/2"	PS121-355
5-1/2"x 7"	PS122-557
5"x 6"	PS123-056
7"x 11"	PS124-711
8-1/2"x 11"	PS125-085
11"x 14"	PS126-114

*Frames available in beige, black, red and white.

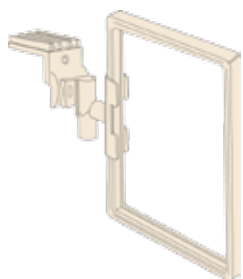

Sign Frame with Self-Centering Undershelf Mount

3-1/2"x 5-1/2"	PS151-355
5-1/2"x 7"	PS152-557
5"x 6"	PS153-056
7"x 11"	PS154-711
8-1/2"x 11"	PS155-085
11"x 14"	PS156-114

*Frames available in beige, black, red and white. Includes stem mount.

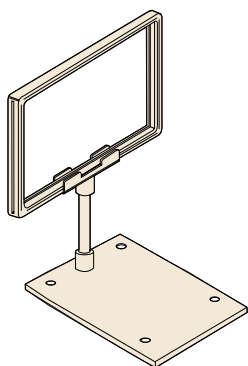

Sign Frame with Shovel Base (Includes Stem Mount)

3-1/2"x 5-1/2"	PS010-355
5-1/2"x 7"	PS010-557
5"x 6"	PS010-056
7"x 11"	PS010-711
8-1/2"x 11"	PS010-085
11"x 14"	PS010-114

*Frames available in beige, black, red and white.
**Also available with 2", 6", 8" 10", & 12" stem.

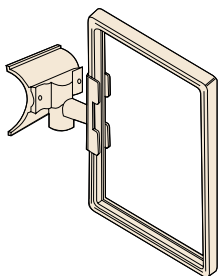

Sign Frame with Self-Centering C-Channel Mount (Includes Stem Mount)

3-1/2"x 5-1/2"	PS145-355
5-1/2"x 7"	PS146-557
5"x 6"	PS147-056
7"x 11"	PS148-711
8-1/2"x 11"	PS149-085
11"x 14"	PS150-114

*Frames available in beige, black, red and white. Includes stem mount.

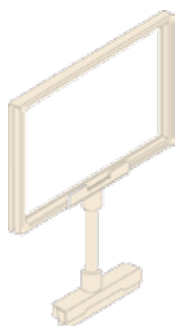

Sign Frame with Magnetic Stem Base (Includes Stem Mount)

3-1/2"x 5-1/2"	PS134-355
5-1/2"x 7"	PS134-557
5"x 6"	PS134-056
7"x 11"	PS134-711
8-1/2"x 11"	PS134-085
11"x 14"	PS134-114

*Frames available in beige, black, red and white
**Also available with 2", 6", 8" 10", & 12" stem.

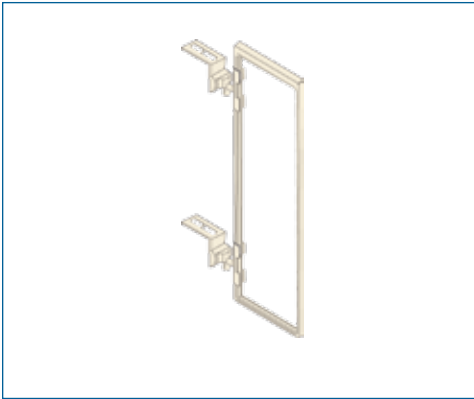

Sign Frame with Self-Centering Undershelf Swivel Mount (Includes Stem Mount)

5-1/2" x 24"	PS175-524
5-1/2" x 36"	PS175-536

*Frames available in beige, black, red and white.

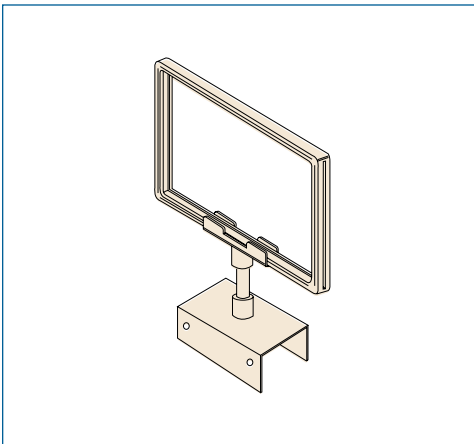

Sign Frame with Gondola Stem Base (Includes Stem Mount)

3-1/2" x 5-1/2"	PS140-355
5-1/2" x 7"	PS140-557
5" x 6"	PS140-056
7" x 11"	PS140-711
8-1/2" x 11"	PS140-085
11" x 14"	PS140-114

*Frames available in beige, black, red and white
 **Also available with 2", 6", 8" 10", & 12" stem.

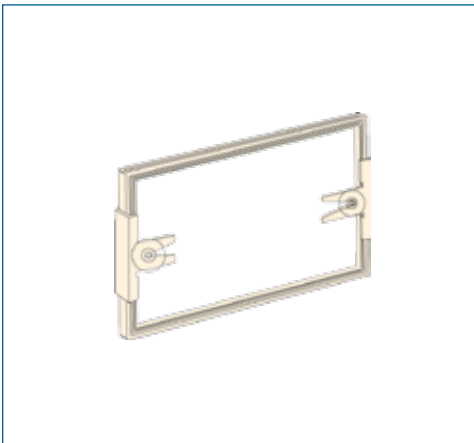

Sign Frame with Suction Cup (Includes 2 Suction Cups)

3-1/2" x 5-1/2"	PS170-355
5-1/2" x 7"	PS170-557
5" x 6"	PS170-056
7" x 11"	PS170-711
8-1/2" x 11"	PS170-085
11" x 14"	PS170-114

*Available in beige, black, red and white.

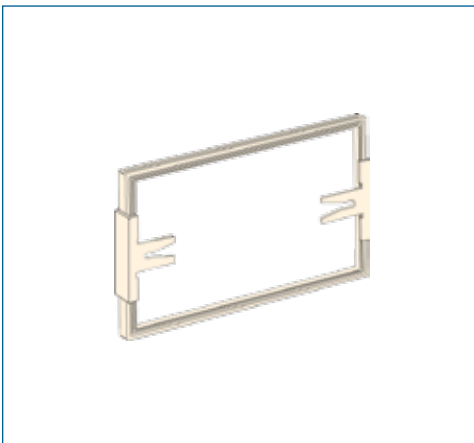

Sign Frame with Wall Mount (Includes 2 Wall Mounts)

3-1/2" x 5-1/2"	PS171-355
5-1/2" x 7"	PS171-557
5" x 6"	PS171-056
7" x 11"	PS171-711
8-1/2" x 11"	PS171-085
11" x 14"	PS171-114

*Available in beige, black, red and white.

SIGN-HOLDER SOLUTIONS

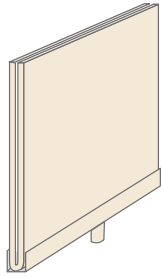

Clear Signholder with Metal Base

Chrome Finish.

7"W x 5-1/2"H

SH0755CRB

11"W x 7"H

SH0117CRB

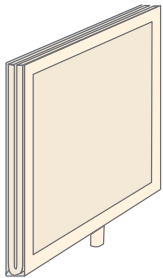

Metal Signholder

Chrome Finish.

7"W x 5-1/2"H

SH0755CS

11"W x 7"H

SH0117CS

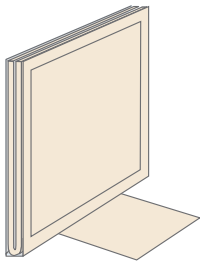

Metal Signholder with Shovel Base

Chrome Finish.

7"W x 5-1/2"H

SH0755CSB

11"W x 7"H

SH0117CSB



Metal Threaded Swage Stem

Chrome Finish.

3"

SHA300B

6"

SHA600B



Metal Threaded Stem

Chrome Finish.

3"

SHA300A

6"

SHA600A

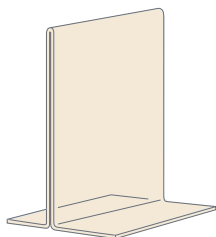

Clear Inverted T-Signholder

8-1/2" x 11"	INVT8511
7" x 11"	INVT0711
5-1/2" x 7"	INVT0557
3-1/2" x 5-1/2"	INVT3555

*Custom sizes available.

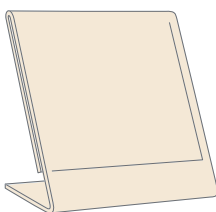

Clear L-Angled Signholder

8-1/2" x 11"	LSH8511
7" x 11"	LSH0711
5-1/2" x 7"	LSH0557
3-1/2" x 5-1/2"	LSH3555

*Custom sizes available.

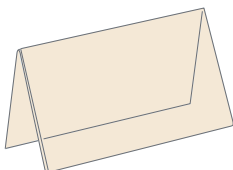

Clear Tent-Shaped Signholder

3-1/2" x 5-1/2"	TESH0001
5-1/2" x 7"	TESH0002

*Custom sizes available.

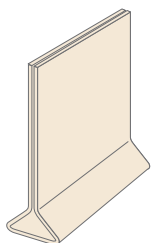

Clear Top Mount Signholder

5" x 3"	TOP0053
---------	---------

*Custom sizes available.

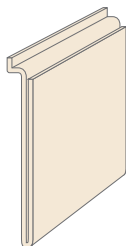

Clear Slatwall Foldover Signholder

8-1/2" W x 11" H	SLF08511
7" W x 11" H	SLF00711
5-1/2" W x 7" H	SLF00557
3-1/2" W x 5-1/2" H	SLF03555

*Custom sizes available.

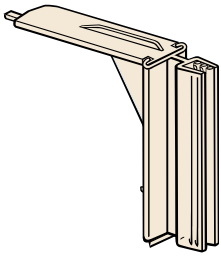

Shelf Top SuperGrip® Signholder with Hinge

Fits most perforated shelves. Sign Holder capacity is .100”
Sign holder capacity is .100”.

SHC039SMHG

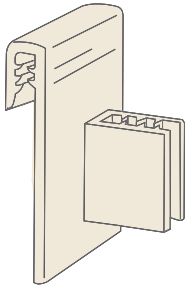

Clear Extruded Signholder Clip

Moulded in clear PVC. Attaches to flat surfaces.
Holds material up to .065” thick at a 90° angle.

SHT0612



NEW

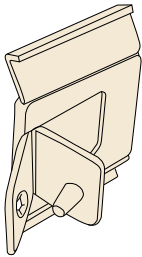

Snap-It Signholder

Snaps onto a price channel and holds signs perpendicular to the shelf.

SHC045



NEW

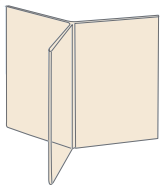

Clear Tri-Card Signholders

Holds up to 6 cards each measuring 7” W x & 11”H. Made in Copoly.

TRI1107

*Custom sizes available. Minimum quantities apply.

NEW

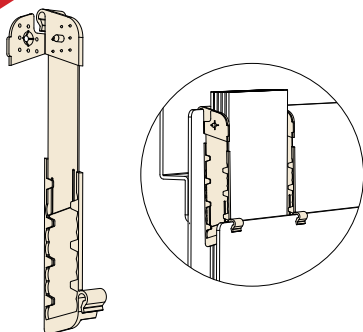

Greeting Card Divider

The Greeting Card Divider system reinforces existing card fixtures and keeps your product organized. Adjustable height from 4” to 6”. The integrated folding signholder allows for double-sided graphics. Fits most wire and flat fences. Made of Polyethylene.

CARDDIV104

Available in White, Black and Natural
*Custom colours available. Minimum quantities apply.





CLEAR SIGNHOLDER SOLUTIONS

Our clear signholder solutions provide an effective way to advertise your new products, sales or services on tables, countertops or shelves.

HOW DOES IT WORK?

Clear Signholder Solutions

A. Clear Signholder with Clear Angled Base Holder

B. Clear Signholder with Clear T-Base Holder

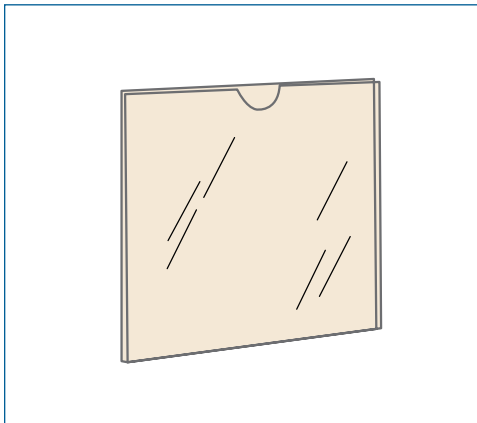

Clear Signholder

Can be used with adhesive or base holders. Equipped with stoppers so signs can be used horizontally or vertically and cards will not slip out.

2" x 6"	SHO26CLEAR
4" x 6"	SHO46CLEAR
5-1/2" x 7"	SHO557CLEAR
8-1/2" x 11"	SHO8511CLEAR

*8-1/2" W x 11" H Signholder comes with thumb notch for easy graphic removal.

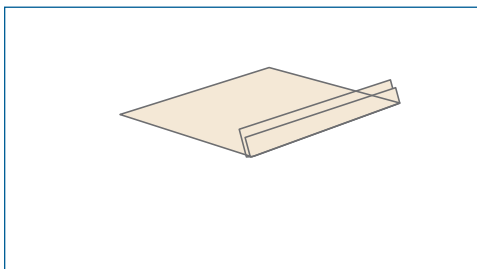

Clear Angle Base Holder

Copoly extruded base, 2-1/4" deep. Cut to required length to fit clear signholders.

SHC055CLEAR

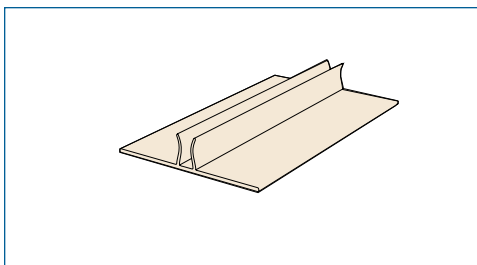

Clear T-Base Holder

Copoly extruded T-base. Cut to required length to fit clear signholders.

SHE3094CLEAR

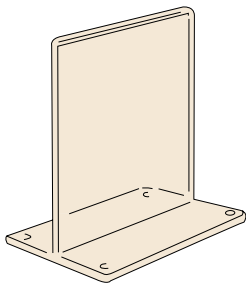

Clear T-Shaped Signholder

Display signs on countertop, shelf or table. Graphic loads from top. Made in clear styrene.

4" x 6" CLSIG205

8-1/2" x 11" CLSIG200

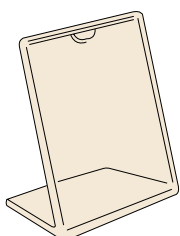

Clear L-Shaped Signholder

Display signs on counter top, shelf or table. Graphic loads from top. L-Shape allows signage to be displayed for applications where an angled view works best. Made in clear styrene.

4" x 6" CLSIG215

5" x 7" CLSIG220

8-1/2" x 11" CLSIG225

*Custom sizes available.

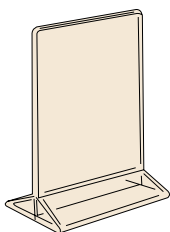

Clear Y-Shaped Signholder

Display signs on counter top, shelf or table. Graphic loads from top. L-Shape allows signage to be displayed for applications where an angled view works best. Engrave on the base and maximize your selling space. Made in clear styrene.

4" x 6" (Engraveable Area : 4"W x 1-1/8"H) CLSIG210

*Custom sizes available.

NEW

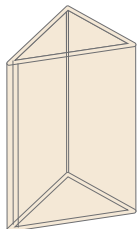

Clear 3-Sided Signholder

For material 4" wide and 6" high.

4"W x 6"H TRI46

6"W x 4"H TRI64

*Custom sizes available. Minimum quantities apply.

NEW

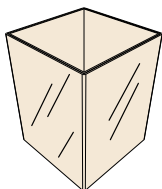

4-Sided Signholder

For graphics 5"W x 7"H.

5-1/4" W X 7-1/8" H CUBE0507

*Custom sizes available . Minimum quantities apply.



HANGING BOARDS

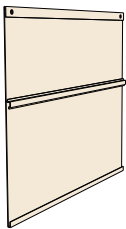

Small Single-Sided Hanging Boards

10-3/4" overall height. Top section fits a 4" message insert card and the bottom section fits 6" flip number cards.

Black	SHE0782SBLACK
White	SHE0782SWHITE

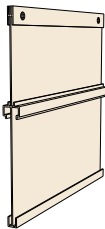

Small Double-Sided Hanging Boards

10-3/4" overall height. Top section fits a 4" message insert card and the bottom section fits 6" flip number cards. Cards can be displayed on both sides.

Black	SHE0782DBLACK
White	SHE0782DWHITE

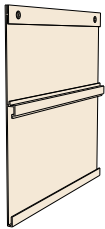

Large Single-Sided Hanging Boards

19" overall height. Top section fits a 6-1/4" message insert card and the bottom section fits 11" flip number cards.

Black	SHB703SBLACK
White	SHB703SWHITE



Large Double-Sided Hanging Boards

19" overall height. Top section fits a 6-1/4" message insert card and the bottom section fits 11" flip number cards. Cards can be displayed on both sides.

Black	SHB703DBLACK
White	SHB703DWHITE



Small Flip Number Set

Numeral / \$ Pads (2"W x 3-9/16"H)	HBSM0010
Numeral / ¢ Pads (1-3/8"W x 3-9/16"H)	HBSM0020
Reader Pads (1-3/8"W x 3-9/16"H)	HBSM0030



Large Flip Number Set

Numeral / \$ Pads (5-5/16"W x 11-1/8"H)	HBLG0010
Numeral / ¢ Pads (3"W x 11-1/8"H)	HBLG0020
Reader Pads (3"W x 11-1/8"H)	HBLG0030

AISLE MARKERS

THE ULTIMATE SHOPPER STOPPER!

Get these silent salespeople working for you! Double-sided for twice the exposure. Injection moulded corners are twin-pronged for maximum stability. Quality mitre-edge finish. Use our mounting accessories to hold your signs on slatwall, pegboard, or a shelf. Makes a great gondola topper too. Standard colours are white, black, red and beige. Custom colours and lengths available.

*Minimum Quantities Apply.



1 Piece Moulded Aisle Marker

Sturdy, moulded in high impact styrene. Available in black and white

5-1/2" x 24"	SHOMMF5524
5-1/2" x 36"	SHOMMF5536

*Custom colours available. Minimum quantities apply.

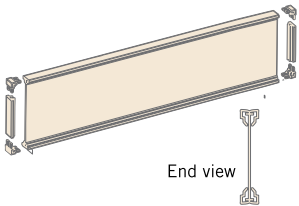

Aisle Marker

Aisle marker with rigid banner support.

3-1/2" x 48" (29mm x 1219mm)	MMF348
5-1/2" x 48" (140mm x 1219mm)	MMF548

*Frames available in beige, black, red and white. Available in different sizes.

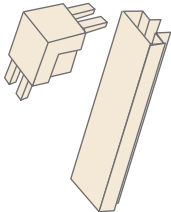

Custom Frames (Corners and Edging)

Custom sizes are available. Build custom frames using corners and side pieces.

Custom Frame Edging	CFR001
Custom Frame Corners	CFR002

HOW DOES IT WORK?

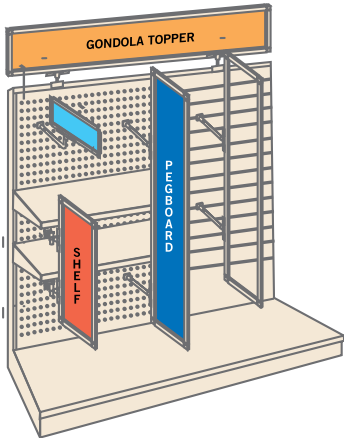

**Aisle Markers
with Mounting Accessories**

Slide your signs into both sides of the extruded frame wall. Secure them in place with a top, bottom and twin-pronged corners. Display it vertically or horizontally with our mounting accessories. Use with our Self-Centering Mounts and your Aisle Marker will bounce back if bumped. The Strip Mount Card Holder can also be used in the same way to create quick and easy aisle signage.

Use with our various mounting accessories. Here are some examples:

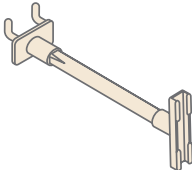

Pegboard / Slatwall Extension Mount
SHA116WHITE10

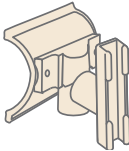

Self-Centering C-Channel Mount
SHA033

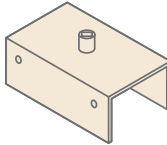

Gondola Center Stem Base
SHB014

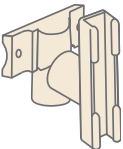

Self-Centering Wall / Post Mount
SHA035

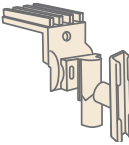

Self-Centering Under Shelf Swivel Mount
SHA034

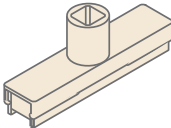

Magnetic Stem Base
SHB011

HOW DOES IT WORK?

Dual Frame Mounting Accessories

Simply measure the length of your signage to provide us with the length of Dual Frame required. Then choose the pegboard mounting accessory that works best for your application.

Secure Banner with
2 Pieces of Dual Frame

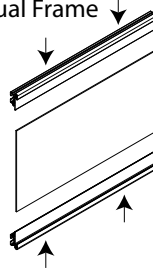

Select a Mounting Option

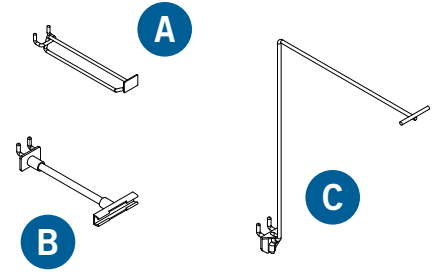

NEW

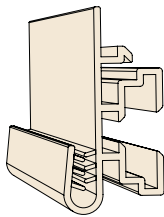

Dual Frame

Dual frame extrusion with gripper. Gripper fits .040" - .080" plastic. Can be hung using standard store hooks or stems and hooks.

1" - 96" Long

SHE0817

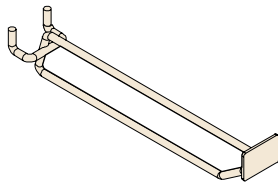

A

Fish Tip™ or Flip Scan Hook

Hang dual frame mount using stock scan hooks or Fish Tip™ or Flip Scan Hook.

8"

HK0820

*Available in various stock lengths.

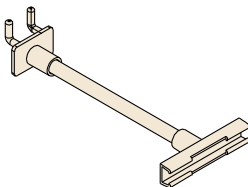

B

Pegboard/Slatwall Mounting Kit

Compatible with our sign frame components.

10" Stem

SHA116WHITE10

NEW

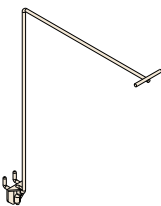

C

Sign Riser

Upright Set of 2

Kit Includes: 2 Pegboard/Slatwall Mounts 2 Uprights

UPR002



NEW

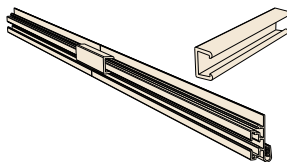

Dual Frame Connector

Create any width of sign by connecting multiple lengths.

SHE2301M

HOW DOES IT WORK?

Bracket Sign System

Make your own signs with these interchangeable brackets and sign holders. Signholders are available in different colours and sizes. Gripper mounts can be used to mount signage in flag style. Frame type signholders can be used when signage protection is required. Brackets work with pegboard, and uprights.

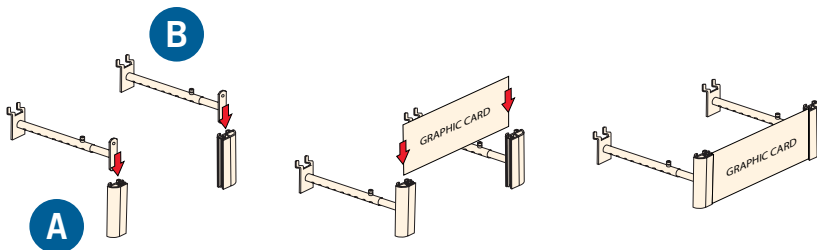

A

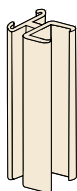

Clear Sign Frame Adapter

Works with the Bracket Sign System. Available in 3" length. Made in PVC.

SIGN100

A

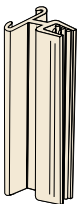

Clear Sign Frame Gripper

Works with the Bracket Sign System. Hinged and 3" in length.

SIGN105

A

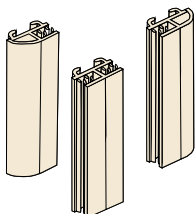

SuperGrip® Header Signholder

Accepts material thickness from .060"-1/4". 4" lengths available in clear, black or white.

Centre Sign Grip Holder

SIGN110

End Connector Sign Grip Holder

SIGN115

*Please specify colour when ordering.

B

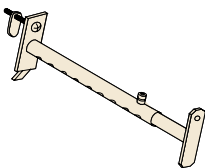

Gondola Upright Metal Telescopic Bracket

3/4"W x 3"H mounting area. Compatible with signholder adapters. Slides onto mounting plate 1/16" capacity. Adjustable 13"-21" length. Powder-coated in beige.

TELGON100

B

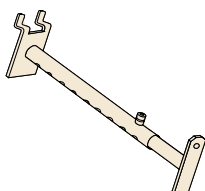

Pegboard Metal Telescopic Bracket

3/4"W x 3"H mounting area. Compatible with signholder adapters. Adjustable 13"-21" length. Powder-coated in beige.

TELPEG100

CARD CLIPS

Card clips are a cost effective and efficient ways to highlight sales, new merchandise or display advertisements to your shoppers. Choose from a variety of designs, sizes and colors.

HOW DOES IT WORK?

Slatwall

Fence

Aisle Sign

Wire

Shelf Front

NEW

Pivoting Sign Clip

Versatile sign clip holds a graphic card. Mounts directly to C-Channel as well as slatwall, wire, and shelf front channel.

SIGN210

*Minimum quantities apply.

PERFORATED / WIRE / PEG CARD CLIPS

These card clips make the ultimate shelf talker! Holds cards parallel or perpendicular to the shelf. No adhesive or mounting hardware required. Holds card 10pt. - 30 pt. thickness.

Perforated Shelf Card Clip

Attaches to shelf perforations. Holds a card 5 different ways (0.01" - 0.03" thickness).
US Patent #7515852

SHA070

Wire / Peg Card Clip

Fastens to a peg, hook or wire bin. Holds a card five different ways (10 pt. - 30 pt. thickness).
US Patent #7515852

SHA071

HOW DOES IT WORK?

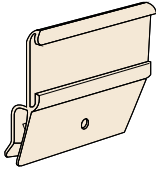

Basket Clip

To be used with wire bins. Will hold label size of 1-3/8" x 3". Available in clear.

SHE2208CLEAR03

*Custom colours available. Minimum quantities apply.

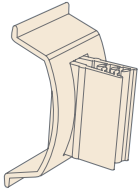

SuperGrip® Flag C-Channel Card Holder

Securely holds signs in the flag position. Fits most standard 1-1/4" shelf channels. Holds material up to .080" thick. 3/4" wide. Made of clear PVC.

SHC047

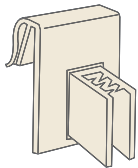

Clear Extruded Hinged Signholder

Moulded in clear PVC. Accepts material up to .065" thick. Holds card at a 90° angle.

SHT0613

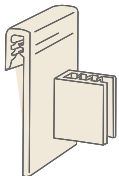

Extruded Signholder Clip

Moulded in clear PVC. Attaches to flat surfaces. Holds material up to .065" thick at a 90° angle.

SHT0612

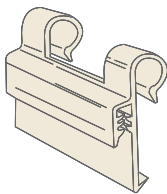

Clear Extruded Wire Basket Signholder

Moulded in clear PVC. Fits wire up to 5/16" in diameter. Measures 1 3/8" in width.

SHT0619

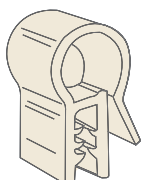

Clear Extruded Wire Basket Card Clip

Moulded in clear PVC. 1/2" wide. Fits wire up to 3/8" diameter.

SHT0609

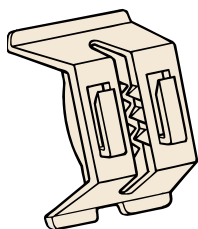

Double Duty Shelf Channel Signholder

Snaps onto a C-Channel and displays price cards perpendicular and vertical to shelf.

SHC046

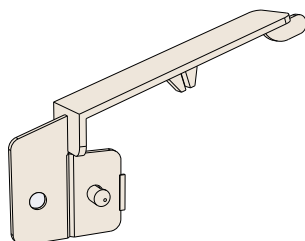

Fold N Hold Flag Signholder

For use on perforated shelves. Punctures signs to securely display them in the flag position. Holds signs up to .012" thick.

SHC041

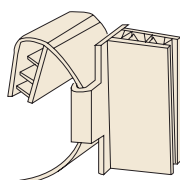

Clear Adjustable Signholder

Adjusts to the angle of the shelf.

PX611

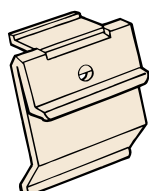

Fold N Hold Shelf Channel Flush Signholder

Punctures and holds signs securely. Fits most standard 1" shelves. Holds most paper signs up to .012" thick.

SHC042

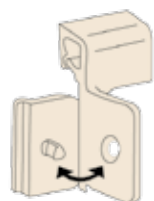

Clip-In Data Strip Fold N Hold

Hooks into a data strip to hold your advertising (up to .012" thick) at a 90° angle into the aisle. Made of natural polypropylene.

SIGN205

NEW

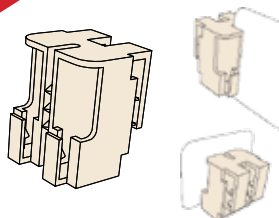

2-Way Sign Grip Clip

Clear 2-way sign grip clip can be used with Flip Scan, Clear Scan and C-Channel 7/8" x 1-1/8".

SHC071

SIGNHOLDER & BASE CLIPS

Display information to your customers in a convenient way. These versatile card and label holders provide a clear view of your message and marketing material.

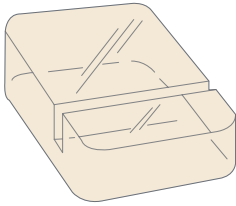

Clear Price Ticket Cube

Clear acrylic cube accepts inserts from .020" - .150". Slot holds cards at an angle. Perfect for price tickets in showcases.

1-1/2" L x 1- 1/2" W

SHC026

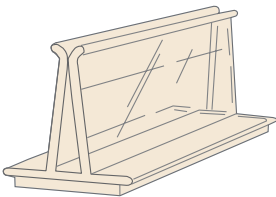

Clear Grip Signholder

Accepts inserts from .015" to .125". Wider base and taller sides give better stability. Permanent adhesive on base.

3" L x 1-1/8"W x 7/8" H

SHC020

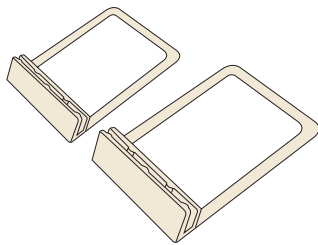

Angled Card Holder

1-1/4"x 1-3/4" (Base)

SHC817

2"x 2-1/2" (Base)

SHC818

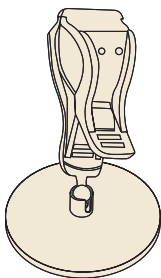

Memo Clip with Magnetic Base

Memo clip with plastic countertop base.

SHT1270

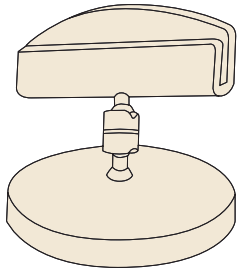

Clear Card Holder with Base

Adjust your sign to the angle of your shelf.

Plastic Base	SHT5241
Magnetic Base	SHT4701

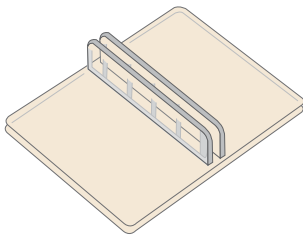

Clear Centre Mount Signholder

Ribbed design holds paper signs secure. Holds paper signs up to 1/32" thick.

1-7/8"x 1-3/4"	SHC010
----------------	--------

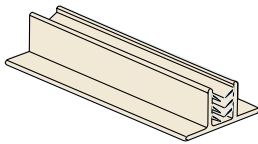

Small Base Clip

Small size is ideal for hard to sign areas. Gripper teeth accept material up to .080". Standard lengths available in 1" and 3". 1/2" wide base. Custom lengths available.

1"	SHC030CLEAR01
3"	SHC030CLEAR03

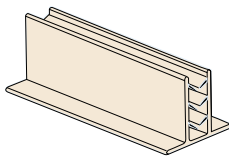

Large Base Clip

Ideal for foam board, Coroplast™ or corrugated signs. Accepts signs up to 3/16" to 1/4" thick. Standard lengths in 3" and 6". 1-1/2" wide base. Custom lengths available.

3"	SHC035CLEAR03
6"	SHC035CLEAR06

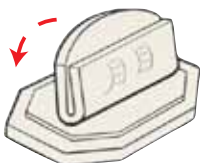

Clear Countertop Adjustable Signholder

Tilts to view your sign from above or below. Holds material 8 pt. – 20 pt. thick.

SHT2021

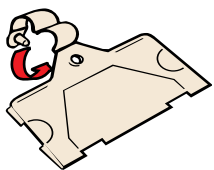

Fold N Hold Covered Ticket Holder

Hinged clasp fits up to .375" diameter wire. Easy load access.

2"W x 1-1/4"H tickets

HK050

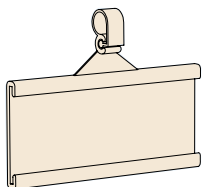

Fold N Hold Ticket Holder

Natural polypropylene.

2"W x 1-1/4"H

HK056

3"W x 1-1/4"H

HK057

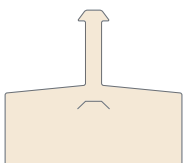

Wide UPC / Label Holder

Translucent white finish.

2-1/4"W x 1-1/4"H

HK051

3-3/8"W x 1-1/4"H

HK052

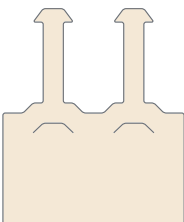

Double Loop UPC / Label Holder

Translucent white finish.

2-1/2"W x 1-1/4"H

HK053

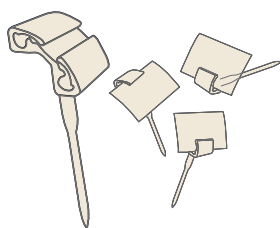

Price Spear

1-31/32" L Clear

SHT0003

1-31/32" L White

SHT0003W

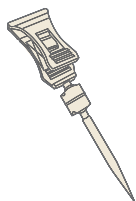

Clear Plastic Pin with Memo Clip

1-31/32" L

SHT0105

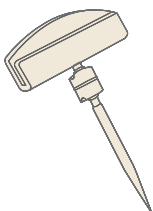

Clear Plastic Pin with Large Card Holder

1-31/32" L

SHT0405

CLIP-ONS

THE COLOURFUL, FUN WAY TO DISPLAY SIGNAGE!

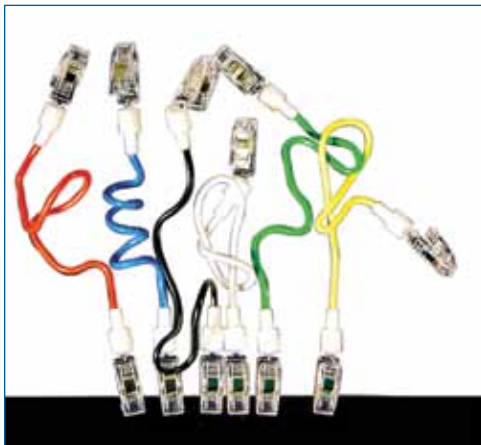

Curly Wire Clips

White	KK10W
Black	KK10K
Yellow (Fluorescent)	KK10Y-FLO
Green (Fluorescent)	KK10G-FLO
Blue (Fluorescent)	KK10B-FLO
Orange (Fluorescent)	KK10O-FLO
Pink (Fluorescent)	KK10P-FLO

Available in bold, bright colours, these 1/8" diameter wires are 12" long and can be bent to any shape you like. Attach a sign at each end, or attach one end to your fixture. Available in fluorescent colours: orange, green, pink, yellow and blue.



Clip-On Adhesive Adapter for Wire

Wire clip on one side, adhesive pad on the other. White plastic. 1" total length.

KK011



Clip-On Adhesive Adapter

Clip one end to a fixture and stick the other end to a sign, or vice-versa. Tilts in any direction. 2-1/4" in length.

KK012



Double Clip-On Signholder

Clip at each end. Pivots in any direction. 3-1/2" total length. Clips hold material up to 3/8" thick.

KK013



Clip-On Signholder

Clip one end to a fixture and stick the other end to a sign, or vice-versa. Tilts in any direction. 2-1/4" in length.

KK014



Clip-On 2" Signholder

Clip on one end, 2" wide signholder on the other end. Holds material 8 pt. – 20 pt. thick. Pivots in any direction. 4" total length.

KK015



Clip-On Spring Signholder

Extra-strong grip. Pivots in any direction. 4" total length. 3-1/8" wide sign clip for material up to 1/4" thick.

KK016



Clip-On Extended Signholder

Clip on one end, 2" wide signholder on the other end. Holds material 8 pt. – 20 pt. thick. Pivots in any direction at the top and bottom.

6" L

KK017



Clip-On Extended Spring Signholder

Extra-strong grip. Pivots in any direction at top and bottom. 6¼" total length. 3-1/8" wide sign clip for material up to ¼" thick.

6-1/4" L

KK018



Clip-On Extended Sign Protector

Protects your sign with a clear cover. Pivots at both ends. Display signs up to 1/32" thick. Clear cover available in two sizes.

5-1/2"W x 3-1/2"H

KK019A

7"W x 5"H

KK019B



Clip-On Wire Signholder

Clip at the base, 4" rigid wire in the middle, 1" wide signholder at the top. Holds material 8 pt. – 20 pt. thick. Pivots in any direction at both ends.

7-1/2" L

KK020



Magnetic Clip-On Signholder

Strong magnetic base, grips most metal surfaces. Holds material up to 3/8" thick. Pivots at top and bottom. White base.

7" L

KK021



Suction Cup Clip-On Signholder

For glass and other smooth surfaces. Holds material up to 3/8" thick. Pivots at top and bottom.

6-1/2" L

KK022

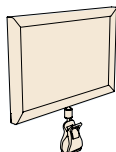

Clip-On Sign Protector

Display material 5-1/2"W x 3-1/5"H up to 1/32" thick. Clip grips material up to 1-1/8" thick.

KK023

BROCHURE HOLDER



BROCHURE HOLDERS & ACRYLIC ACCESSORIES

Display brochures and sales materials in any retail situation, with all the impact they deserve.

 **marketingIMPACT**
LIMITED

displaypeople.com



4 Tier Double Brochure Holder

BH0470

BROCHURE & BUSINESS CARD HOLDERS

MAXIMIZE EXPOSURE TO INCREASE SALES!

Use every opportunity to make an impact and promote your product or service! Choose from a large selection of durable and affordable brochure holders. Our literature holders are perfect for displaying and organizing your pamphlets and sell sheets. Don't see what you're looking for? Let us custom design one for you!

*Items with screw-mounting holes require hardware sold separately.

CUSTOM DESIGNED LITERATURE HOLDERS

Let our design team create a literature holder custom to suit your needs.



Slant Back Brochure Holder

BH0220

CUSTOM BROCHURE HOLDERS

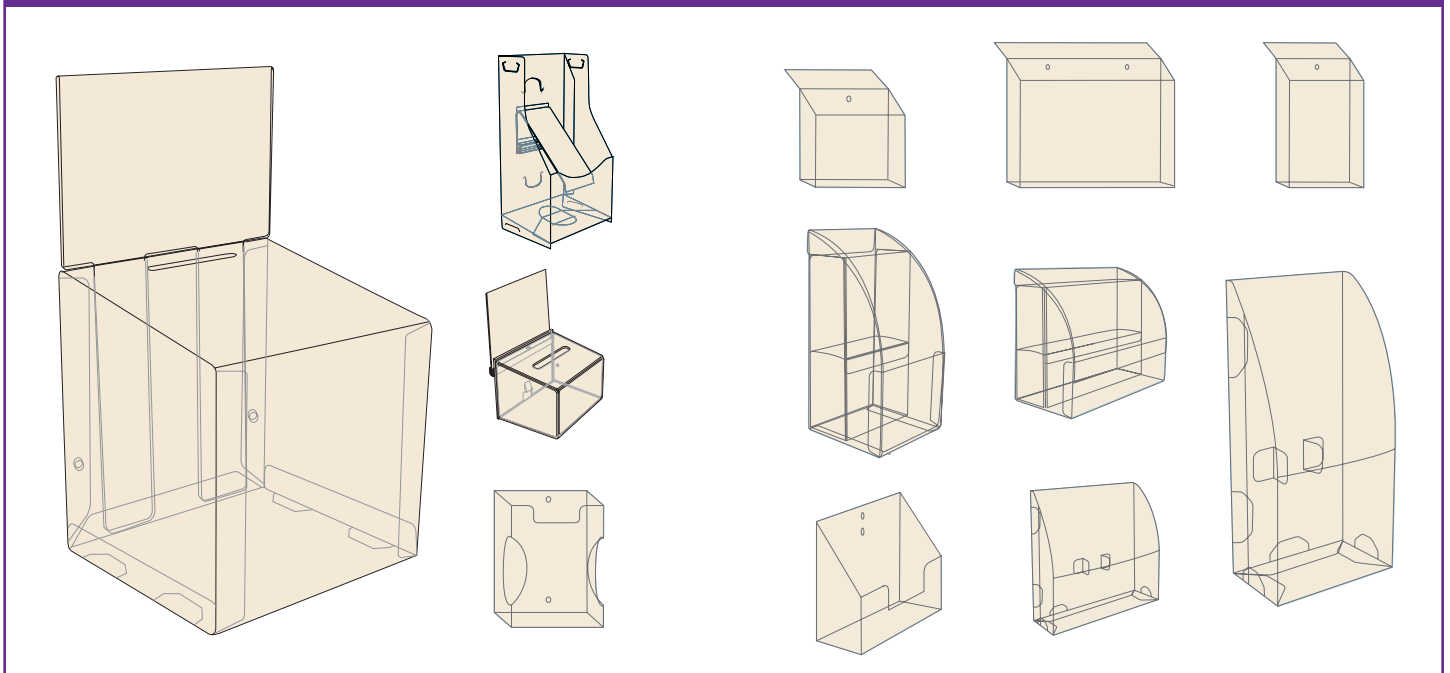

NEW

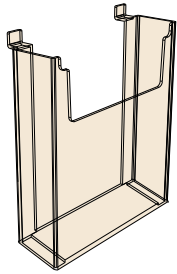

Magazine Pocket Holder

Injection molded. Mounts to slatwall to display standard size 8-1/2" x 11" magazines.

8-1/2"W x 11"H

BH0320

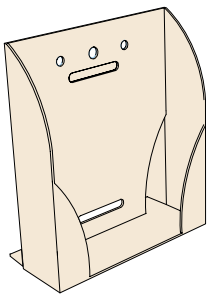

CD / Brochure Holder with Feet

Holds CDs and brochures. Injection Moulded.

5-1/8"W x 5-3/4"H

BH0031F

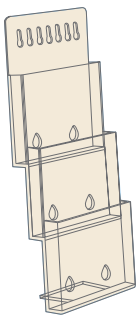

Extended Pocket Brochure Holder

Injection moulded. Holds cards 4"W x 5-1/2"H
Sits on counter or hangs on wall.

BH0480

*Hardware sold separately

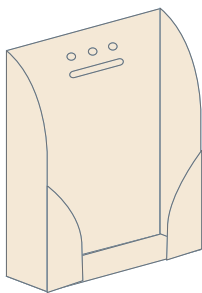

CD / Brochure Holder

Holds CDs and brochures. Injection Moulded.

5-1/8"W x 5-3/4"H

BH0030

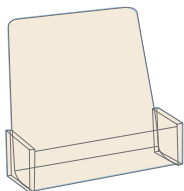

Single Business Card Holder

Counter top business card holder. Injection moulded in clear styrene.

5-1/8"W x 5-3/4"H

BH0130

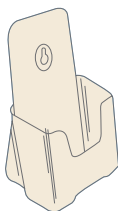

Slant Back Wall-Mounted Brochure Holder

Slant-back holder with screw mounting hole. Injection moulded in clear styrene.

6-3/4"W x 7-3/4"H

BH0230

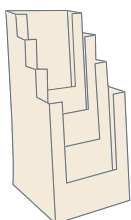

4 Tier Traditional Brochure Holder

Slant back holder with 4 compartments. Can be used on counter top. Injection moulded in clear styrene.

4-1/4" W x 10" H

BH0400

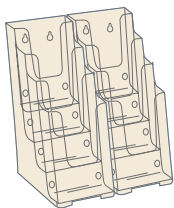

4 Tier Double Brochure Holder

Slant back holder with 8 compartments. Injection moulded in clear styrene.

8-1/2" W x 7-3/4" H

BH0470

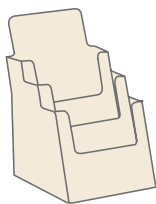

3 Tier Slant Back Brochure Holder

Slant back holder with 3 compartments. Holds brochures or literature up to 8" wide. Injection moulded in clear styrene.

9-1/4" W x 13-3/4" H

BH0410

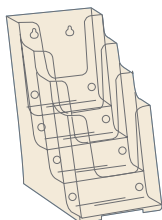

4 Tier Slant Back Brochure Holder

Slant back holder with 4 compartments. Can be used on counter top or wall mounted. Injection moulded in clear styrene.

6-7/8" W x 10" H

BH0430

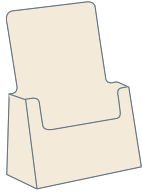

Slant Back Brochure Holder

Slant back. Sits on counter top. Injection moulded in clear styrene.

4-1/4"W x 7-1/4"H

BH0220

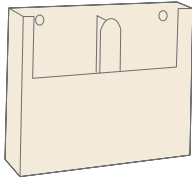

Traditional Double Brochure Holder

For material up to 4-1/2" wide. Injection moulded in clear styrene.

9-5/8"W x 8"H

BH0440

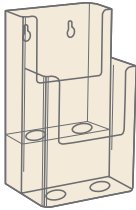

2 Tier Wall Mounted Brochure Holder

For material up to 3-3/4" wide. Injection moulded in clear styrene.

4-1/4" W x 6-7/8" H

BH0450

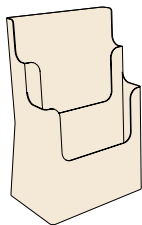

2 Tier Slant Back Brochure Holder

For material up to 8-1/2" wide. Injection moulded in clear styrene.

8-3/4"W x 13-3/4"H

BH0460

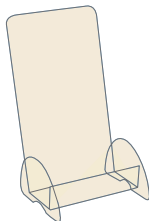

Euro-Style Green Edge Brochure Holder

Injection moulded. Holds cards 4"W x 8"H. Injection moulded in clear styrene.

4-5/16" W x 8" H

BH0510

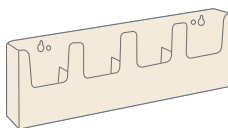

4 Pocket Brochure Holder

Injection moulded. Holds cards up to 3-1/2" wide. Sits on counter or hangs on wall. Injection moulded in clear styrene.

15-3/8" W x 5" H

BH0520

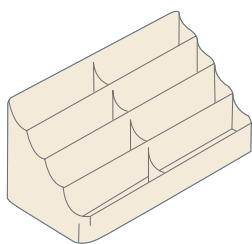

4 Tier Double Business Card Holder

Displays business cards on counter top with 8 compartments. Made in clear acrylic. Injection moulded in clear styrene.

BH0140

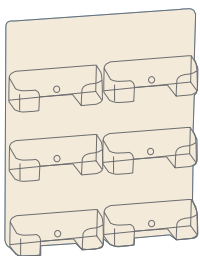

3 Tier Double Wall-Mounted Business Card Holder

Mounts on wall. Has 6 compartments. Hold multiple business cards at once. Injection moulded in clear styrene.

BH0150

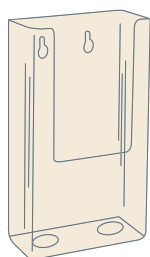

Traditional Wall-Mounted Brochure Holder

With screw mounting holes for wall mounting. 1-5/8" deep pocket capacity. Injection moulded in clear styrene.

4-1/8"W x 7"H

BH0210

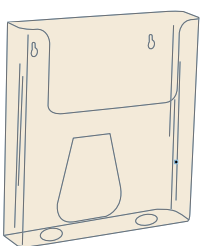

Wall-Mounted Brochure Holder (Wide)

With screw mounting holes. 2" deep capacity to hold literature up to 8-1/2" wide. Injection moulded in clear styrene.

8-3/4"W x 9-1/2"H

BH0310

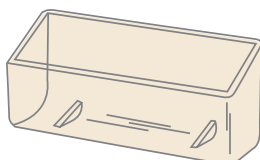

Card Holder

Attaches to any holder or ad frame. Injection moulded in clear styrene.



3-7/8" W x 1-1/5" H x 2" D

SHD006CLEAR

ACRYLIC ACCESSORIES

WE PRIDE OURSELVES ON OUR CUSTOM CAPABILITIES!

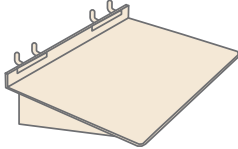
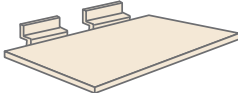
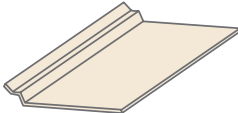
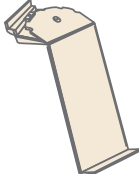
When it comes to custom displays we can accommodate your every need. Every stage from concept to finished product is handled with care by highly qualified professionals. Inquire today!

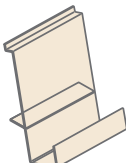
	<h3>Slatwall / Pegboard Shelf</h3> <p>Made in Clear Acrylic</p> <p>12" x 6" SLSH010ACR</p> <p style="text-align: right;">*Custom sizes available.</p>
	<h3>Slatwall Utility Shelf</h3> <p>Injection moulded in clear plastic.</p> <p>12"W x 6"D SLSH020ACR</p>
	<h3>Slatwall Shoe Shelf</h3> <p>Injection moulded in clear plastic.</p> <p>Clear Acrylic 10"W x 4"D SLSH030ACR</p> <p>Clear Styrene 10"W x 4"D SLSH030STY</p>
	<h3>Slatwall Adjustable Shoe Shelf with Toe Stop</h3> <p>Acrylic SLSH040ACR</p> <p>Styrene SLSH040ACR</p>
	<h3>Slatwall Magazine Holder with Spring Front</h3> <p>Made in Clear Acrylic</p> <p>8" W x 11" H SHD001CLEAR</p> <p style="text-align: right;">*Custom sizes available.</p>
	<h3>Slatwall Magazine Pocket</h3> <p>Made in Clear Acrylic</p> <p>9" W x 11-1/2" H SHD002CLEAR</p>
	<h3>Slatwall Magazine Holder</h3> <p>Made in Clear Acrylic</p> <p>9" W x 11-1/2" H SHD004CLEAR</p>

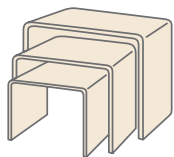

U-Shaped Risers

Made in Clear Acrylic

3" X 3" X 3"

4" X 4" X 4"

5" X 5" X 5"

SHD020CLEAR

*Custom sizes available.

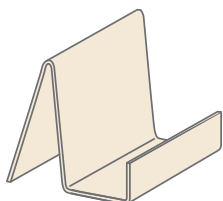

Counter Top Book Easel

Made in Clear Acrylic

SHD003CLEAR

*Custom sizes available.

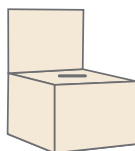

Ballot Box

Made in Clear Acrylic. Includes a 6-1/2" H x 8" W Sign Header.

8"W x 8"H x 8"D

SHD005CLEAR

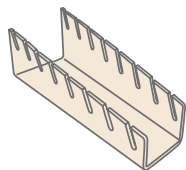

Plate Holder

Made in Clear Acrylic. Holds up to 8 plates.

SHD015CLEAR

*Custom sizes available.

ACRYLIC ENGRAVING

SPECIAL FEATURE

Strengthen brand identity by having your corporate logo or store name engraved on your acrylic holders, signs and displays.

Call us for details.



SHELF TICKETING

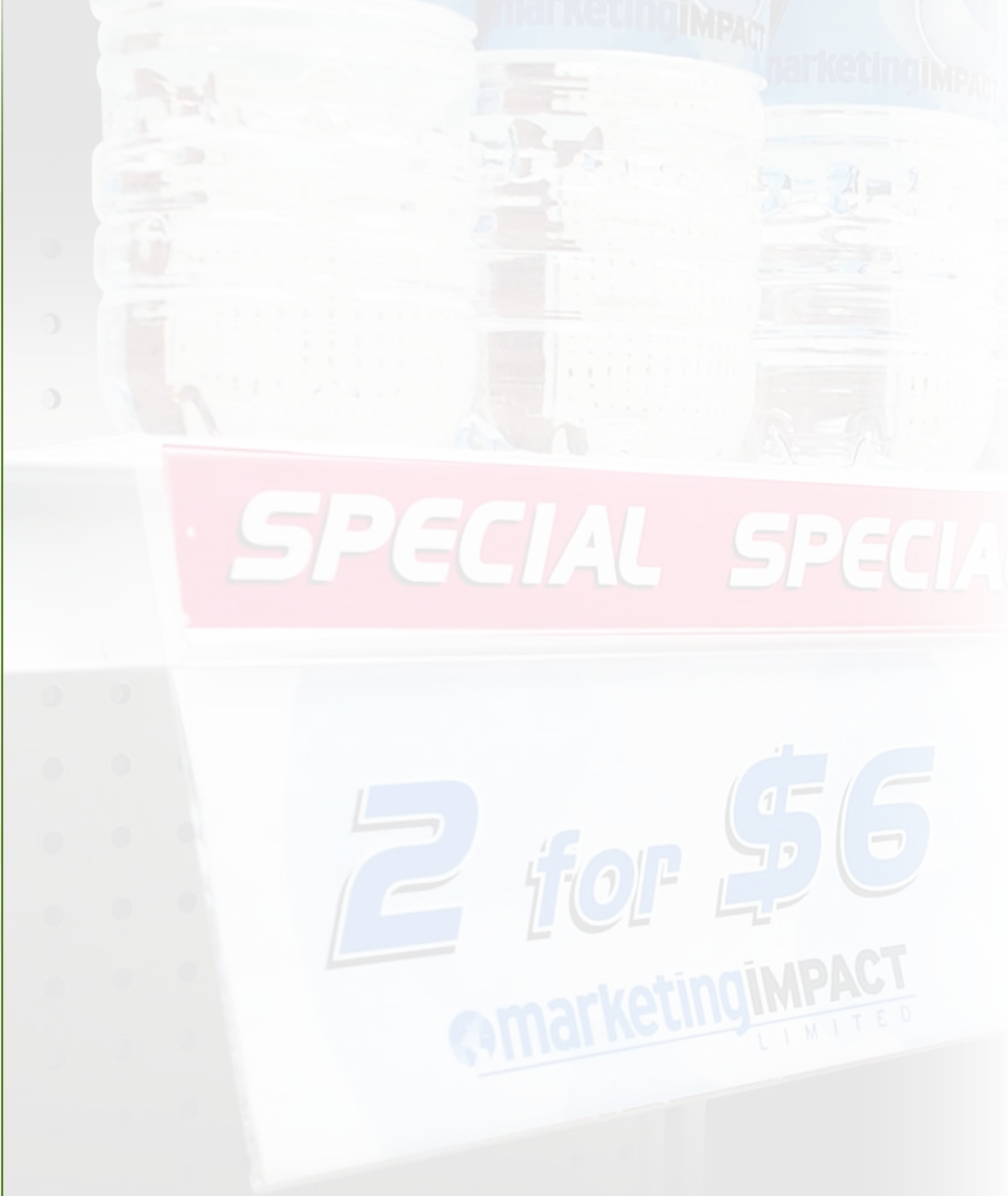

SHELF TICKETING STRIPS

An amazing array of shelf ticket and inventory management solutions.

 **marketingIMPACT**
LIMITED

displaypeople.com

SHELF TICKET MOULDINGS

Choose from our stock extrusions, or let us design the part you need.

*Custom colours are available. Minimum quantities apply.

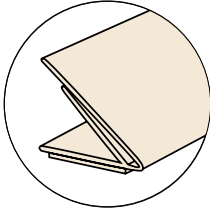

Angled Card Holder with D-Tape

Holds labels on an angle with permanent adhesive tape. Manufactured in PVC.

3/4"H x 47-7/8"L

SHE2551

*Available in white.

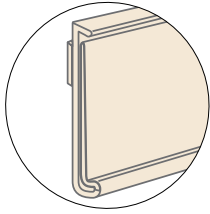

Label Holder with D-Tape

Manufactured in PVC.

1-1/4"H x 47-7/8"L

SHE0511

1-1/2"H x 47-7/8"L

SHE0619

1-3/4"H x 47-7/8"L

SHE0620

*Available in white, black and clear.

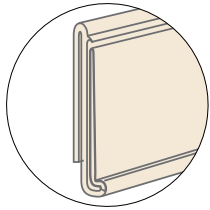

C-Channel Label Holder

Snaps into price channel. Manufactured in PVC.

1-1/4"H x 47-7/8"L

SHE0711

*Available in white, black and clear.

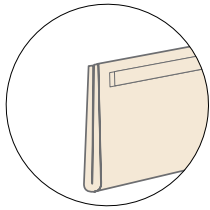

2" High Self-Adhesive Data Strip and Label Holder

Manufactured in PVC.

2"H x 47-7/8"L

SHE2067CLEAR/CLR

*Available in clear.

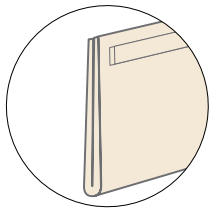

3" High Self-Adhesive Data Strip and Label Holder

Manufactured in PVC.

3"H x 47-7/8"L

SHE2070 CLR

*Available in clear.

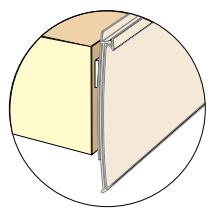

C-Channel Label Holder with Adhesive

Manufactured in PVC.

1-1/4"H x 47-7/8"L

SHE3015

*Available in white and clear.
Please specify colour when placing order.



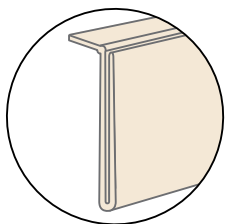

Flip Label Holder

Manufactured in clear PVC. Label holder is slotted with holes for mounting onto standard metal shelves with push pins. (Refer to p.135 for hardware.)

1-1/4"H x 47-7/8"L	SHE0897
3"H x 47-7/8"L	SHE2046

NEW

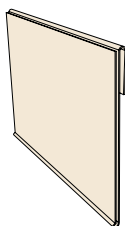

4" Flip Channel

Data Strip mounts to shelf with foam tape. Manufactured in clear PVC.

4"H X 47"L	SHE0287CLEAR
------------	--------------

Available with slot for mounting

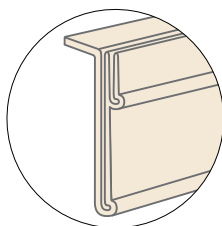

Signholder Extrusion

Extrusion will hold 2 Data Strips. Top / Front Channel is 1-1/4"H. Manufactured in clear PVC.

4"H x 47-7/8"L	SHE2251
----------------	---------

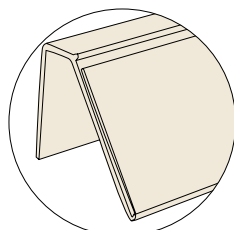

Shelf Label Holder

Manufactured in PVC.

1-1/4"H x 47-7/8"L	SHE0276
--------------------	---------

*Available in white and clear front.

NEW

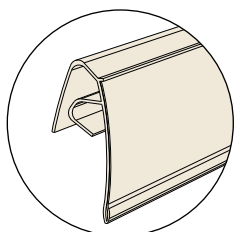

Wire Channel Clip

Channel clip mounts onto wire. Manufactured in PVC.

1-1/2"H x 23-1/4"L (Clear)	SHE0191CLEAR/CL23
1-1/2"H x 23-1/4"L (Black)	SHE0191BLACK/CL23
1-1/2"H x 34-5/8"L (Clear)	SHE0191CLEAR/CL34
1-1/2"H x 34-5/8"L (Black)	SHE0191BLACK/CL34

*Available in clear and black. Please specify when placing order.

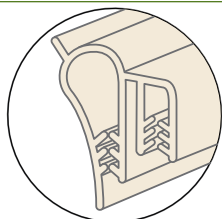

Hinged Basket Clip Gripper

Snap into a C-Channel shelf or clips onto wire or a flat surface. It allows up to 8 pt. card to hang. Manufactured in PVC.

3/4"W x 1"H	SHC070CLEAR
-------------	-------------

*Available in white.



Clear Dual Extrusion

SHE2031

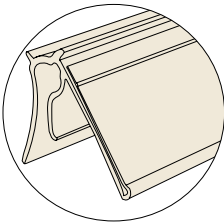

Clear Wire Shelf Ticket Channel

Fits over 1/4" wire holder. Manufactured in PVC.

1-1/4"H x 3"L

SHE3075CLEAR

*Available in clear.

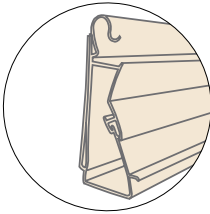

Clear Dual Extrusion

Clips into C-Channel, stands alone or clips onto wire. Great for shelf fronts. Manufactured in PVC.

2-1/4"H x 4-1/4"L

SHE2031CLEAR

*Available in clear.

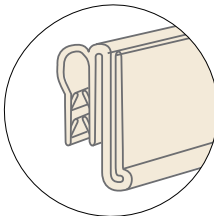

Hinged Extrusion

Mounts to wire or glass up to 3/8" thick. Manufactured in PVC.

1-1/4"H x 47-7/8"L

SHE2248CLEAR

*Available in clear.

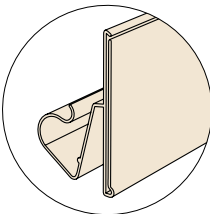

Wire / Basket Shelf Label Holder

Manufactured in PVC.

1"H x 47-7/8"L

SHE2136

*Available in clear.

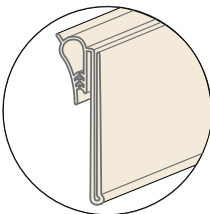

Large Hinged Extrusion

Clips onto wire up to 3/8" thick. Can also be clipped onto glass and in a C-Channel. Manufactured in PVC.

3-1/2"H x 6"W

SHE2249CLEAR

7"H x 11"W

SHE2312CLEAR

*Available in clear.

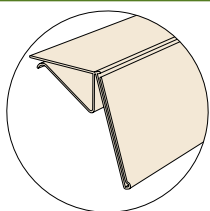

Glass Mount Shelf Label Holder

Manufactured in PVC.

1"H x 47-7/8"L

SHE2158

*Available in clear.

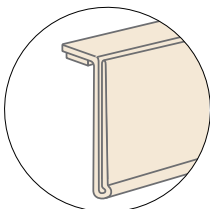

Glass Shelf Extrusion - 90° Angle

Attaches to the top of a shelf with permanent adhesive tape. Manufactured in PVC.

1-1/4"H x 47-7/8"L

SHE1776CLEAR

*Available in clear.

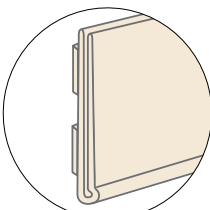

3" Label Holder with D-Tape

Attaches to a flat surface with two pieces of permanent adhesive tape. Manufactured in PVC.

3"H x 47-7/8"L

SHE2065WHITE

*Available in white with clear.

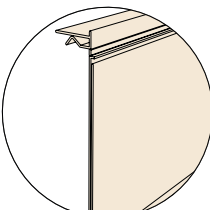

5"x 3" Flip-Up Label Holder For Shelf Ticket Mouldings

Clips onto glass or wood shelf edge. Manufactured in PVC.

5"H x 3"L

SHE2137

*Available in clear.

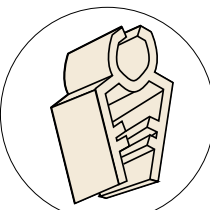

1" Straw Clip

Clips onto multiple edges.

1"W x 1"H

SHE0862CLEAR01

*Available in clear.

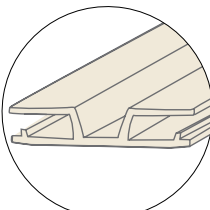

Bulk Bin Hinge

For bins that hold bulk product. Flexible plastic hinge is long wearing and strong. Grips material up to 1/4" thick. Manufactured in PVC.

3/16"H x 15/16"L

SHE943

*Available in clear.

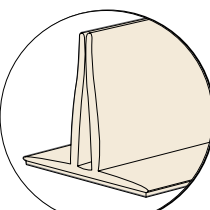

Gondola Top Card Clip

Holds up to 10 pt. card stock. Manufactured in PVC.

1-1/8"W (Base) x 1"H x 3"L

SHC060CLEAR

*Available in clear.

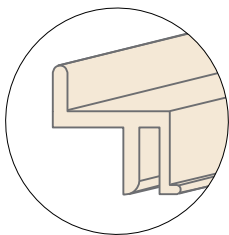

Slatwall Card Holder

Manufactured in PVC.

7/8"W x 1-1/4"H x 2"L

SHE0654CLEAR

*Available in clear.

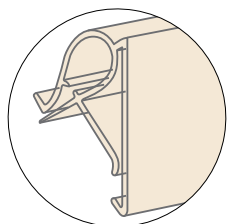

Wire Bin Label Holder

Hooks onto wire and holds labels facing upwards towards the customer for easy reading. Manufactured in PVC.

3"W x 1-1/4"H

SHE2006CLEAR

*Available in clear.

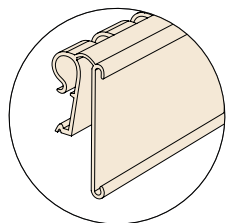

Hinged Label Holder

Holder flips up for easy product removal and quick restocking. Manufactured in PVC.

1-3/4"L

SHE1058CLEAR-SM

2"L

SHE1058CLEAR-LG

*Available in clear.

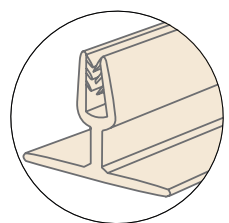

Warehouse Aisle Innovator

Flexible PVC gripper base holds cards vertically to display signage in a flag position. Manufactured in PVC.

1-5/16"H x 47-7/8"L

SHE2140

*Available in clear.

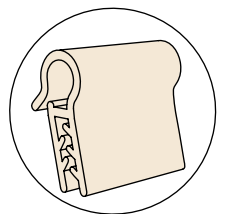

SuperGrip® Wire Flush Signholder

Hooks onto wire and holds label on an angle facing upwards for easy reading. Manufactured in PVC.

1"W x 1"H

SHE0655

*Available in clear.

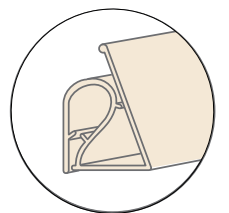

Clear Wire Bin Holder

Hooks onto wire and holds label on an angle facing upwards for easy reading. Manufactured in PVC.

3"W x 1"H

SHE2007

*Available in clear.



Hinged Basket Clip

Manufactured in clear PVC.

3"H x 3-1/2"W SHF0309

*Available in custom lengths.



Basket Clip

Manufactured in clear PVC.

3"H x 2-3/8"W SHF0976

*Available in custom lengths.

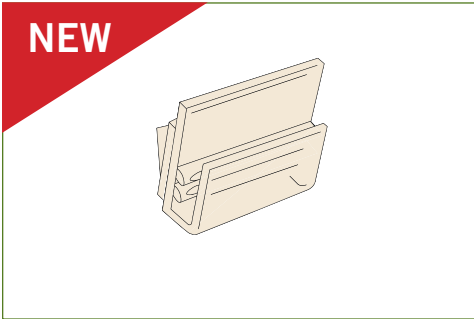

SuperGrip® Signholder

Holds up to .080" thick material. Manufactured in clear PVC.

SHF1802

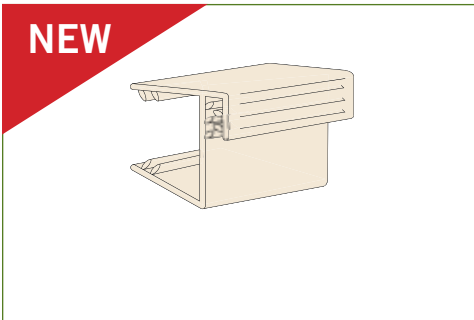

SuperGrip® 1" Flush Signholder

Holds up to .080" thick material. Manufactured in clear PVC.

SHF4801

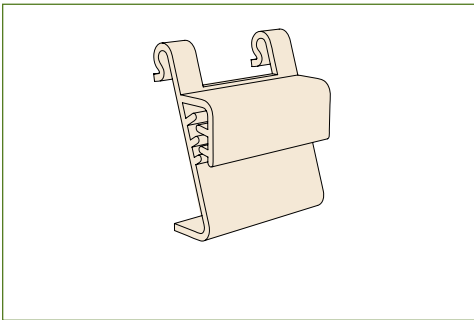

SuperGrip® Wire Signholder

Clips easily over wire up to .375" diamter. 1-3/8" wide holder for material up to .080" thick. Manufactured in clear PVC.

SHT0619

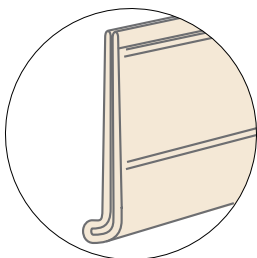

Clear Peghook Label Holder

Hangs from a peghook. Manufactured in PVC.

1-1/4"H x 47-7/8"L

SHE2035CLEAR

*Available in clear.

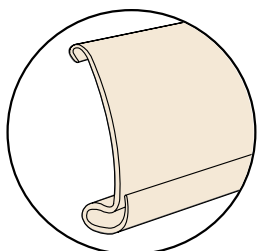

Extrusion Label Holder

Snaps onto a metal C-Channel. Manufactured in PVC.

1-1/3"H x 47-7/8"L

SHE2222

*Available in clear.

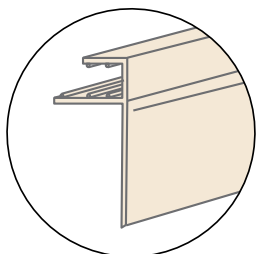

Glass / Wood Label Holder - 90° Angle

For 3/8" glass shelving. Manufactured in PVC.

1-1/4"H x 47-7/8"L

SHE2032CLEAR

*Available in clear.

NEW

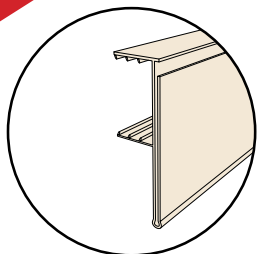

Glass / Wood Label Holder

Manufactured in PVC. For 1-1/2" glass/wood shelving.

2"H x 47-7/8"L

SHE2165CLEAR

*Available in clear.

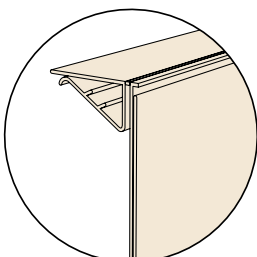

Glass Shelf Flip-Up Label Holder

Fits on shelf up to 3/8" thick. Manufactured in PVC.

3"H x 5"L

SHE287

*Available in clear.

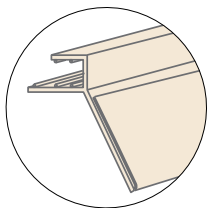

Glass / Wood Label Holder - 45° Angle

For 1/2" glass shelving. Manufactured in PVC.

1-1/2"H x 47-7/8"L

SHE1022

*Available in white with clear front.

NEW

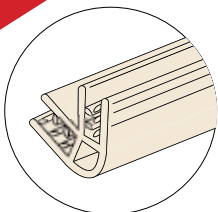

SuperGrip® 60° Panel Former

Two-way connector with fixed 60° angle. Conceals unfinished panel edges. 1/8"-3/16" capacity.

48"L

SHF4602

*Available in clear.

HOW DOES IT WORK?

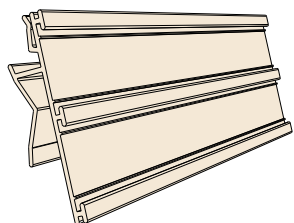

Mount to C-Channel



Mount to Wire



Mount to Shovel Base Holder SHE2378WHITE04



Mount to Wire Clip Holder SHE2379WHITE04

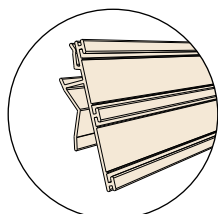

Double Label Holder

Various mounting clips makes this label holder versatile. Mounts directly onto C-Channel or wire shelf. Holds two 1-1/8" high labels or one 2-5/16" high label. Manufactured in PVC.

2-1/2"H x 8-1/2"L

SHE2380WHITE

*Available in white and clear.
Please specify colour when placing order.

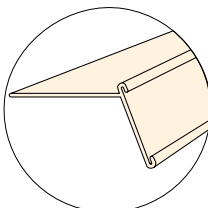

Shovel Base Holder

Attaches to the Double Label Holder (SHE2380WHITE) creating a shovel base to display from the edge of a shelf.

4"L

SHE2378WHITE04

*Available in white.

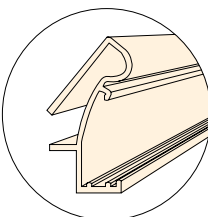

Wire Clip Holder

Attach the Double Label Holder (SHE2380WHITE) and display angled to a flat face.

4"L

SHE2379WHITE04

*Available in clear.

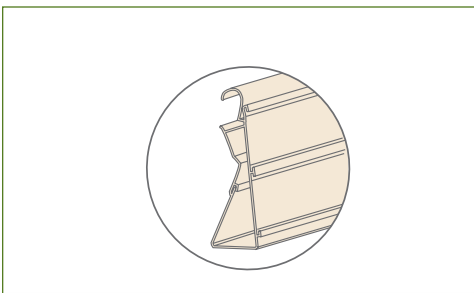

Universal Label Holder

If you're looking for a shelf ticket holder that does it all, look no further. With no less than six distinct functions, this innovation is truly universal. Holds one to two shelf tickets.

Various Lengths Available SHE2178

*Available in white. Custom colours available. Minimum quantities apply.

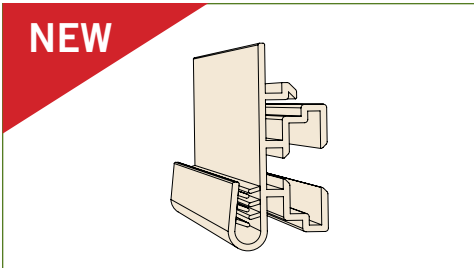

Dual Frame

Dual frame extrusion with gripper. Gripper fits .040" - .080" plastic. Can be hung using standard store hooks or stock stems and accessories.

Various lengths available 1" - 96" SHE0817

*Available in clear, white and black. Please specify colour when placing order.

HOW DOES IT WORK?

Flag Pole Signholder Set
Includes:
 Flag Sign Pole, Pole Holder with double sided tape.
 Holds signs up to 80 pt. and banners.

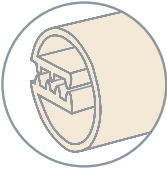
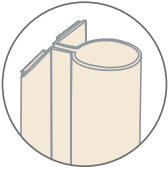
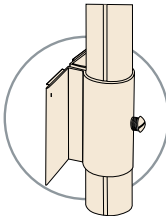
+

=

Pole Gripper
SHF0946

Tube Holder
SHF0961

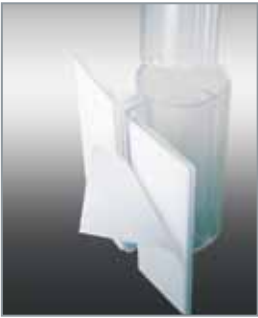
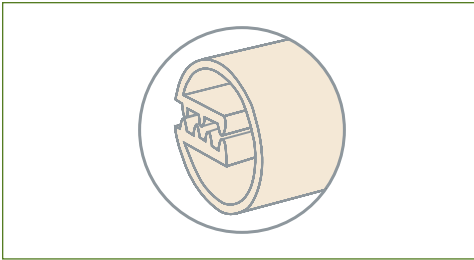
SHF0946 with
SCH0961





Pole Gripper

Use the Pole Gripper in conjunction with the Tube Holder to display up to 80 pt. signage at various heights and locations. Available in blue or red.

SHF0946

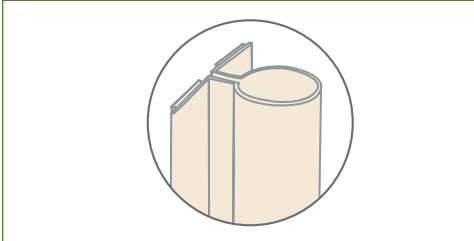
*Custom colors available. Minimum quantities apply.



Tube Holder

Complete with double sided tape, the Tube Holder allows the Flag Pole Signholder Set to be displayed virtually anywhere. Available in blue and red.

SHF0961

*Custom colors available. Minimum quantities apply.



MODULAR MERCHANDISING SYSTEMS

Total shelf merchandising flexibility with versatile pushers, dividers and category management accessories.

 **marketingIMPACT**
LIMITED

displaypeople.com

MODULAR MERCHANDISING SYSTEMS



Light Duty Pusher Setup



Heavy Duty Pusher



NEW Multi-Use Pusher

HOW DOES IT WORK?

Equipping your shelves with pushers and dividers is quick and easy. First, affix the snap bars to your shelf, then simply snap the spring loaded pushers and dividers into place. Fits any shelving system. See our website www.displaypeople.com for a video demonstration.

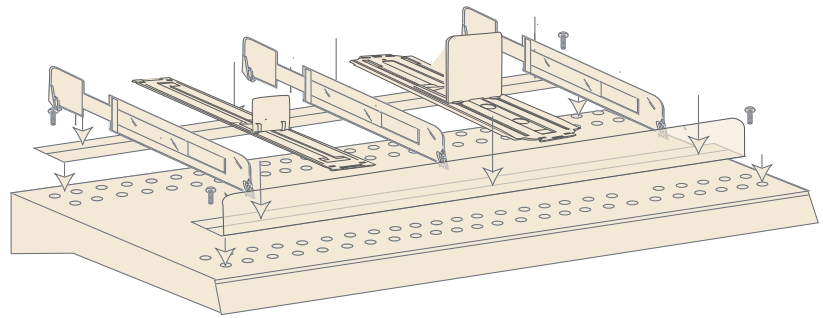

SPRING LOADED PUSHERS

GIVE YOUR SALES A PUSH!

Our pushers keep your products up front where customers can see them and buy them! Made from virtually unbreakable high-impact styrene. Our pushers fit any shelving system and are Maintenance free! Available in white and black. Custom colours available.

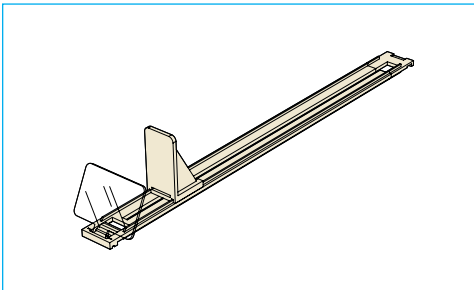

Light Duty Fold N Load™ - 7/8" Wide

12" Length	FLL12
14" Length	FLL14
16" Length	FLL16

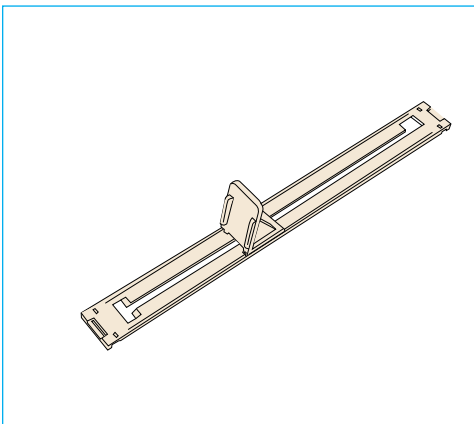

Light Duty Pusher - 7/8" Wide

6" Length	LP06
8" Length	LP08
10" Length	LP10
12" Length	LP12
14" Length	LP14
16" Length	LP16

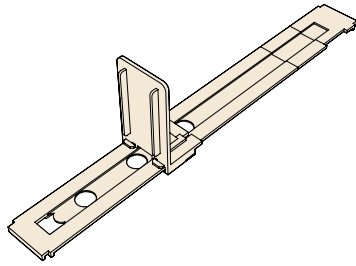

Medium Duty Pusher - 2" Wide

12" Length	MP12
14" Length	MP14
16" Length	MP16
18" Length	MP18

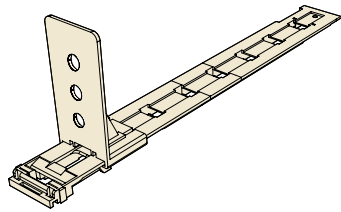

Multi-Use Medium Duty Pusher

16" Length	MCMP16
18" Length	MCMP18
20" Length	MCMP20
22" Length	MCMP22

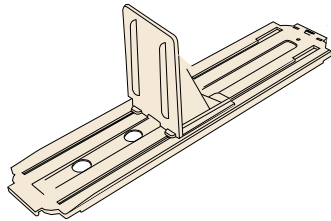

Heavy Duty Pusher - 3" Wide

12" Length	HP12
14" Length	HP14
16" Length	HP16
18" Length	HP18

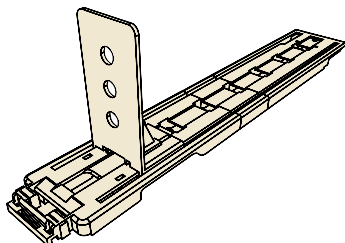

Multi-Use Heavy Duty Pusher

16" Length	CMP16
18" Length	CMP18
20" Length	CMP20
22" Length	CMP22

SHELF DIVIDERS

Our patented Divider design adjusts to suit most shelf depths. Affix easily to shelves with T-Snap Tracks. Use alone or together with Spring-Loaded Pushers. Helps to prevent theft from shelves.

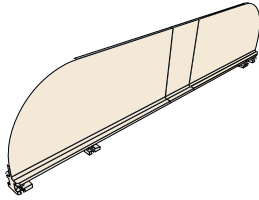

Heavy Duty Divider

Available in black and white high impact styrene.

4" H x 16" L	DIV16
4" H x 18" L	DIV18
4" H x 20" L	DIV20
4" H x 22" L	DIV22

*Custom colours available. Minimum quantities apply.

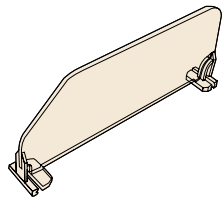

2" Snap-In Divider

Moulded in clear polycarbonate. Available in black and white high impact styrene.

2" H x 7" L	DIV207WHITE
-------------	-------------

*Custom colours available. Minimum quantities apply.

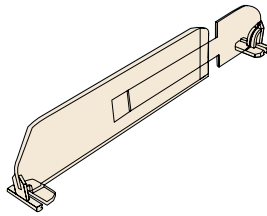

2" Snap-In Adjustable Divider - US PATENT 5803276

Moulded in clear polycarbonate. Available in black and white high impact styrene.

2" H x 10" to 16" L	DIV210
---------------------	--------

*Custom colours available in high-impact styrene. Minimum quantities apply.

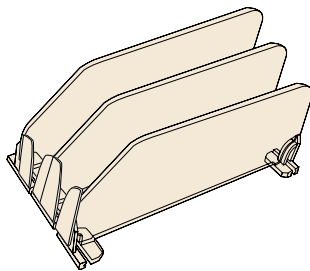

2" Snap-In Adjustable Divider with Front Stops

Moulded in clear polycarbonate.

2" H x 7" L	Left	DIVL207CLRFRTHS
2" H x 7" L	Right	DIVR207CLRFRTHS
2" H x 7" L	Centre	DIVT207CLRFRRT

*Custom colours available in high-impact styrene. Minimum quantities apply.

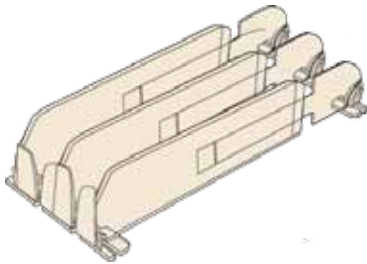

2" Snap-In Divider with Front Stops - US PATENT 5803276

Moulded in clear polycarbonate.

2" H x 10"-16" L	LEFT	DIVL210CLRFRTHS
2" H x 10"-16" L	RIGHT	DIVR210CLRFRTHS
2" H x 10"-16" L	CENTER	DIVT210CLRFRTHS
2" H x 16"-22" L	LEFT	DIVL216CLRFRTHS
2" H x 16"-22" L	RIGHT	DIVR216CLRFRTHS
2" H x 16"-22" L	CENTER	DIVT216CLRFRTHS

*Custom colours available in high-impact styrene. Minimum quantities apply.

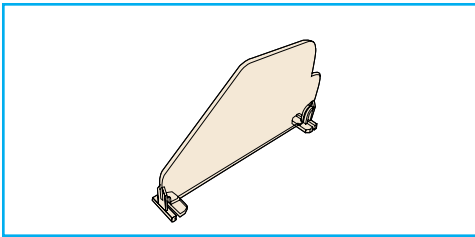

4" Snap-In Divider

Moulded in clear polycarbonate. Available in black and white high impact styrene.

4"H x 7"L

DIV407CLEAR

*Custom colours available. Minimum quantities apply.

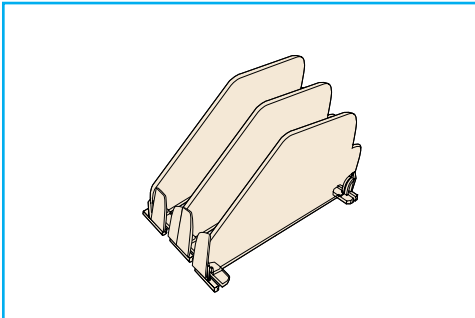

4" Snap-In Divider with Front Stops

Moulded in clear polycarbonate

4"H x 7"L LEFT

DIVL407CLRFRTHS

4"H x 7"L RIGHT

DIVR407CLRFRTHS

4"H x 7"L CENTER

DIVT407CLRFRTHS

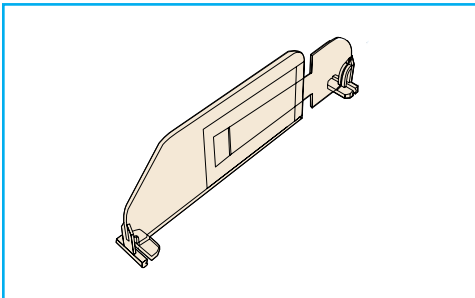

4" Snap-In Adjustable Divider - US Patent #5803276.

Moulded in clear polycarbonate. Available in black and white high impact styrene.

4"H x 10"-16"L

DIVT410

4"H x 16"-22"L

DIVT416

*Custom colours available. Minimum quantities apply.

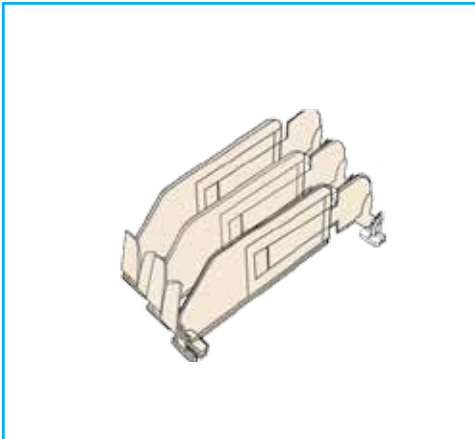

4" Snap-In Adjustable Divider with Front Stops

US Patent #5803276. Moulded in clear polycarbonate.

4"H x 10"-16"L LEFT

DIVL410CLRFRTHS

4"H x 10"-16"L RIGHT

DIVR410CLRFRTHS

4"H x 10"-16"L CENTER

DIVT410CLRFRTHS

4"H x 16"-22"L LEFT

DIVL416CLRFRTHS

4"H x 16"-22"L RIGHT

DIVR416CLRFRTHS

4"H x 16"-22"L CENTER

DIVT416CLRFRTHS

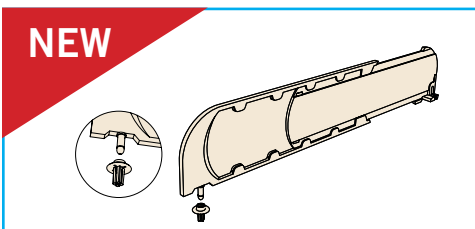

NEW

Thin Adjustable Clip-In Divider - US Patent #5803276.

Moulded in clear polycarbonate. Available in black and white high impact styrene.

DIVP001

*Custom colours available. Minimum quantities apply.

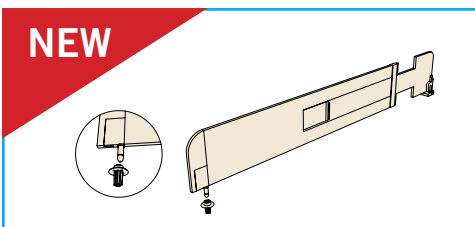

NEW

Adjustable Clip-In Divider - US Patent #5803276.

Moulded in clear polycarbonate. Available in black and white high impact styrene.

DIVP216

*Custom colours available. Minimum quantities apply.

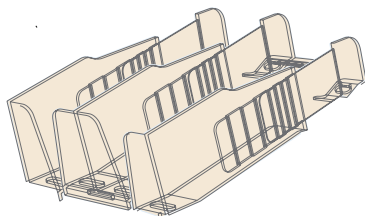

Snap-In Adjustable T-Divider

Adjusts from 12"-16". Fastens onto front and Rear Snap Bars for easy shelf attachment (See p.81). Moulded in high-impact crystal styrene.

4"W x 7"H x 16"D	Adjustable Left End	DIVL512
2"W x 7"H x 16"D	Adjustable Right End	DIVR512
2"W x 7"H x 16"D	Adjustable Centre-T	DIVT512

*Hardware sold separately. See p.135

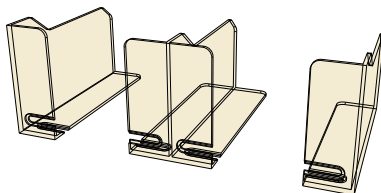

Small Divider

Moulded in clear crystal styrene. Attaches to holes in metal shelves.

1-1/2"W x 3"H x 3"D	Left	DIVL73
1-1/2"W x 3"H x 3"D	Right	DIVR73
3"W x 3"H x 3"D	Centre	DIVT73

*Hardware sold separately. See p.135

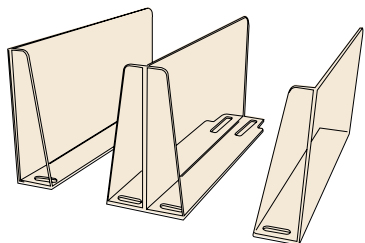

Large Divider

Moulded in clear crystal styrene. Attaches to holes in metal shelves.

2"W x 7"H x 16"D	Left	DIVL167
2"W x 7"H x 16"D	Right	DIVR167
4"W x 7"H x 16"D	Centre	DIVT167

*Hardware sold separately. See p.135

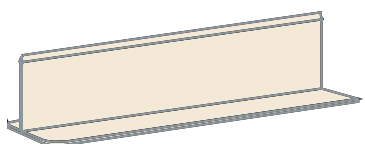

Large Clear Divider with T-Shaped Base

Extruded in clear PVC with radius corners.

3"H x 9-7/8"L	TDIV001
---------------	---------

*Custom lengths available. Minimum quantities apply.

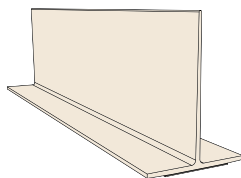

Small Clear Divider with T-Shaped Base

Clear PVC with clear Tesa Tape.

1"H X 10-1/4"L	SHE2502
----------------	---------

*Custom lengths available. Minimum quantities apply.

NEW

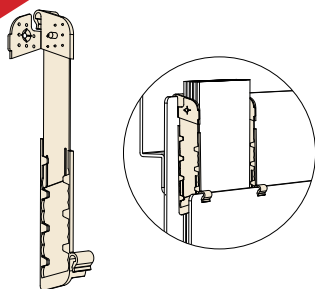

Greeting Card Divider

The Greeting Card Divider system reinforces existing card fixtures and keeps your product organized. Adjustable height from 4" to 6". The integrated folding signholder allows for double-sided graphics. Fits most wire and flat fences. Made of Polyethylene.

CARDDIV104

Available in White, Black and Natural
*Custom colours available. Minimum quantities apply.

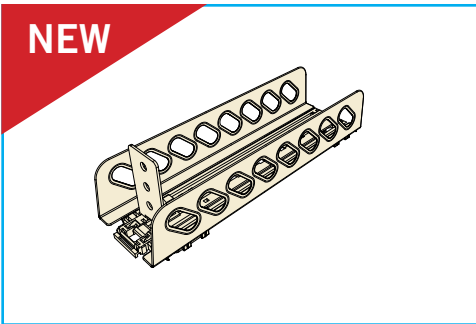

Shelf Mount Pusher with Adjustable Dividers

16"	SMA616
18"	SMA618
20"	SMA620
22"	SMA622

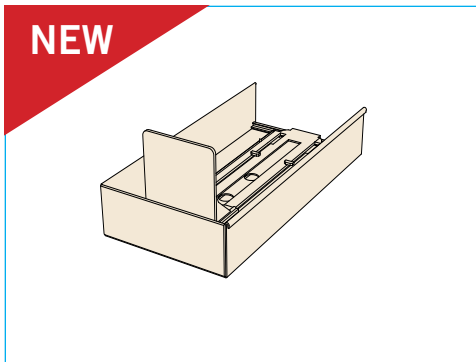

Large Interlocking Pusher Tray

Ideal for pushing bagged pasta/salad. Each tray interlocks to each other. Decal can be affixed to the front fence for product information.

Kit Includes:

- 1 - 6 3/4" Wide Tray
- 1 - Heavy Duty 14" Pusher with Spring
- 1 - 3" High Front Fence
- 1 - Back Rail

6-3/4" W LARINTRAY00114

*Length of tray can be customized from 12" - 22" Long.

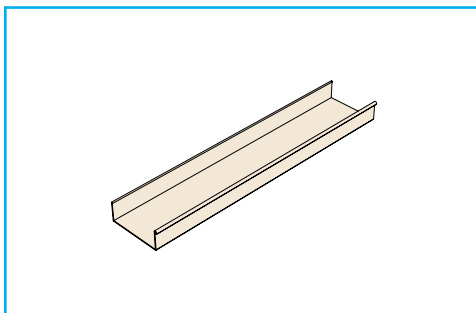

Standard Interlocking Tray

Great idea for organizing bottles, yogurt and much more. Please specify length when ordering.

3"W	SHE2272
2-1/2"W	SHE2197
4-3/4"W	SHE2792

*Available in white . Custom colours available. Minimum quantities apply.

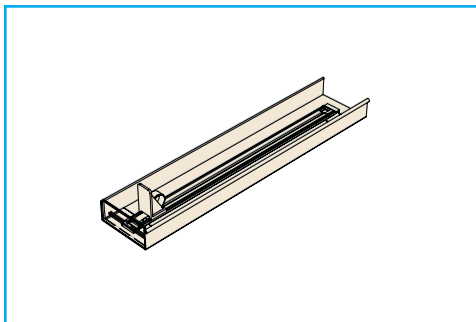

Interlocking Pusher Tray

Ideal for pushing bottled products. Decal can be affixed to the front for product information.

Kit Includes:

- 1 - 3" Wide Tray
- 1 - Medium Duty 16" Pusher with Spring
- 1 - 3" High Front Fence
- 1 - Back Rail

3" W INTERTRAY00116

*Length of tray can be customized from 12" - 16" Long.

SHELF MANAGEMENT MATS & TRAYS

Make the most efficient use of your shelf space and keep products organized with our Shelf Management Mats and Trays. Perfect for cosmetics and other small items. Mats and Trays link together at sides to span the length of any shelf. Insert optional pushers and special dividers for a complete merchandising system.



Cosmetic Tray with Dividers



Shelf Management Mat with Dividers and Light Duty Pushers

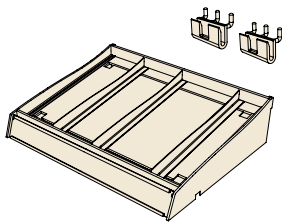

Cosmetic Tray

Clear tray with flip front label holder. Rests on a counter or hooks onto a wall. Locks together on sides. Moulded in crystal styrene. Includes 2 Pegboard/Slatwall Clear U-hooks.

11-7/8"W x 8"D

COSMTRAY-01

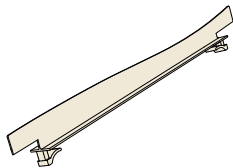

Cosmetic Tray Divider

Dividers slide left and right to adjust to your product width within the cosmetic tray. Moulded in clear styrene. To be used with our Cosmetic Tray.

1-1/8"H x 8"D

COSMDIV208

NEW

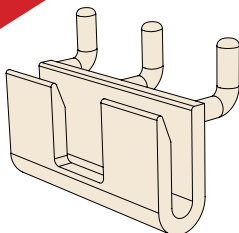

Pegboard / Slatwall Clear U-Hook

Used to hang items from pegboard or slatwall. Moulded in clear polycarbonate.

2-1/4" W

PEG004

SNAP BARS

Used to attach spring-loaded pushers and adjustable dividers to shelves. Apply with double-sided tape, magnetic tape, push pins, or screws (specify preference when ordering). Moulded in clear PVC.

*Custom lengths available.

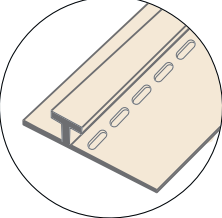
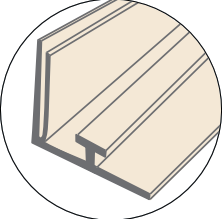
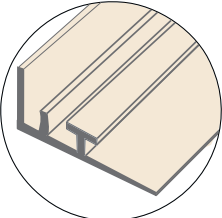
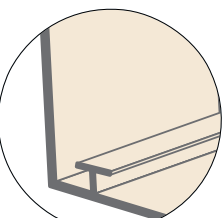
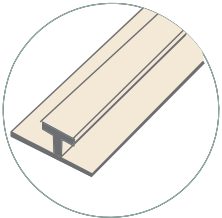
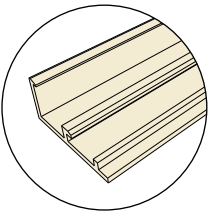
	<h3>Rear T-Snap - Punched</h3> <p>Affix to the front or rear of a shelf to support Pushers and Dividers.</p> <table border="1"> <tbody> <tr> <td>47-7/8" L x 3/16" H x 1-1/8" D with Holes</td> <td>SA127</td> </tr> <tr> <td>47-7/8" L x 3/16" H x 1-1/8" D with Tape</td> <td>SA127DTAPE</td> </tr> </tbody> </table>	47-7/8" L x 3/16" H x 1-1/8" D with Holes	SA127	47-7/8" L x 3/16" H x 1-1/8" D with Tape	SA127DTAPE				
47-7/8" L x 3/16" H x 1-1/8" D with Holes	SA127								
47-7/8" L x 3/16" H x 1-1/8" D with Tape	SA127DTAPE								
	<h3>Label Holder Snap Bar</h3> <p>Affix to the front of a shelf to hold labels while supporting pushers and dividers.</p> <table border="1"> <tbody> <tr> <td>48" W x 2" H x 1-1/2" D</td> <td>SA222</td> </tr> <tr> <td>48" W x 1-1/4" H x 1-1/2" D</td> <td>SA125</td> </tr> </tbody> </table>	48" W x 2" H x 1-1/2" D	SA222	48" W x 1-1/4" H x 1-1/2" D	SA125				
48" W x 2" H x 1-1/2" D	SA222								
48" W x 1-1/4" H x 1-1/2" D	SA125								
	<h3>Snap Bar and Label Holder</h3> <p>Supports adjustable T-Dividers as well as All Pushers and Adjustable Dividers.</p> <table border="1"> <tbody> <tr> <td>48-7/8" L with Holes</td> <td>SHE2177CLEAR</td> </tr> <tr> <td>48-7/8" L with D-Tape</td> <td>SHE2177CLEARDTAPE</td> </tr> </tbody> </table>	48-7/8" L with Holes	SHE2177CLEAR	48-7/8" L with D-Tape	SHE2177CLEARDTAPE				
48-7/8" L with Holes	SHE2177CLEAR								
48-7/8" L with D-Tape	SHE2177CLEARDTAPE								
	<h3>Clear Front Fence</h3> <p>Affix to the front of a shelf. Can be used with our Pushers and Dividers.</p> <table border="1"> <tbody> <tr> <td>47-7/8" W x 1-1/4" H with Holes</td> <td>CLEARFENCE148</td> </tr> <tr> <td>47-7/8" W x 2" H</td> <td>CLEARFENCE248</td> </tr> <tr> <td>47-7/8" W x 2-1/2" H</td> <td>CLEARFENCE2548</td> </tr> <tr> <td>47-7/8" W x 3" H</td> <td>CLEARFENCE348</td> </tr> </tbody> </table>	47-7/8" W x 1-1/4" H with Holes	CLEARFENCE148	47-7/8" W x 2" H	CLEARFENCE248	47-7/8" W x 2-1/2" H	CLEARFENCE2548	47-7/8" W x 3" H	CLEARFENCE348
47-7/8" W x 1-1/4" H with Holes	CLEARFENCE148								
47-7/8" W x 2" H	CLEARFENCE248								
47-7/8" W x 2-1/2" H	CLEARFENCE2548								
47-7/8" W x 3" H	CLEARFENCE348								
	<h3>T-Snap with Foam Tape</h3> <p>Affix to the front and rear of Shelf Management Mat.</p> <table border="1"> <tbody> <tr> <td>48" W x 3/16" H x 9/16" D</td> <td>SHE2758</td> </tr> </tbody> </table>	48" W x 3/16" H x 9/16" D	SHE2758						
48" W x 3/16" H x 9/16" D	SHE2758								
	<h3>Fold N Load Front T-Snap™</h3> <p>A quick and easy way of attaching and adjusting the Fold N Load to a store shelf, finishing off the front edge with a clean and uniform look. Extruded in white PVC.</p> <table border="1"> <tbody> <tr> <td>48" W x 1/2" H x 1 1/8" D</td> <td>SHE0330WHITE</td> </tr> </tbody> </table>	48" W x 1/2" H x 1 1/8" D	SHE0330WHITE						
48" W x 1/2" H x 1 1/8" D	SHE0330WHITE								

PUSHER FRONTS & PADDLES

No matter what your product is, Marketing Impact Limited has a solution for you.



Pusher Finger Front - CLRFRNT005



Pusher Bottle Front - BTNFRONT

NEW

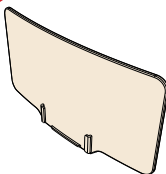

Pusher Curved Front

The Pusher Curved Front can be attached to our Multi-Use Heavy Duty, Multi-Use Medium Duty, and Kwickload™ Pusher Systems. Ideal for bagged product. Moulded in clear polycarbonate.

6-15/16"W x 3-1/2"H

CLRFRNT007

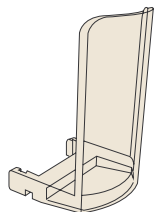

Pusher Bottle Front

The Bottle Front can be attached to our Multi-Use Heavy and Medium Duty Pusher Systems. Manufactured in clear polycarbonate.

2-3/8" W x 3-7/8" H

BTNFRONT

NEW

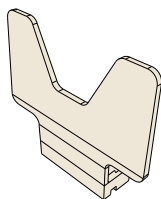

Pusher Clear Front

Clear Front Plate can be attached to our Multi-Use Heavy and Medium Duty Pusher Systems. Manufactured in clear polycarbonate.

3-3/4"W x 4-1/2"H

CLRFRNT001

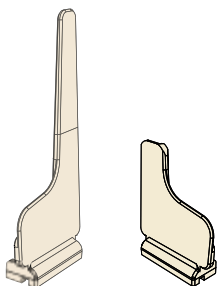

Pusher Finger Front



These Pusher Fronts can be attached to our multi-use heavy and medium duty pusher systems. Manufactured in clear polycarbonate.

3"W x 6-3/4"H (Tall)

CLRFRNT005

3"W x 3-1/2"H (Short)

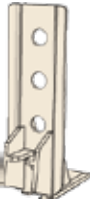
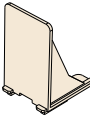
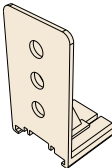
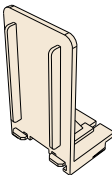
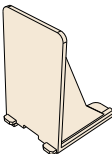
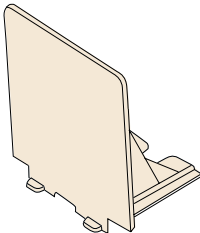
CLRFRNT010

<p>NEW</p> 	<h3>Tall Light Duty Paddle Straight</h3> <p>This Paddle works with our Medium and Heavy Duty Extruded Pushers.</p> <p>1-5/8"W x 4-1/2"H TLDPADDLE</p>	
<p>NEW</p> 	<h3>Tall Light Duty Paddle with Angled Front</h3> <p>This paddle works with our Light Duty Pusher Systems.</p> <p>1-5/8"W x 4-1/2"H TLDPADDLEANG</p>	
	<h3>Light Duty Paddle</h3> <p>This Paddle works with our Light/Medium Duty Slide and Divide Systems.</p> <p>7/8"W x 1-1/2"H LDPADDLE</p>	
	<h3>Medium Duty Paddle</h3> <p>This Paddle works with our Heavy Duty Slide and Divide Systems.</p> <p>2-3/8"W x 4-1/2"H WHDPADDLE</p>	
	<h3>Medium Duty Paddle with Ridges</h3> <p>This Paddle works with our Medium and Heavy Duty Extruded Pushers.</p> <p>2-3/8"W x 4"H MDPADDLE</p>	
	<h3>Heavy Duty Paddle</h3> <p>This Paddle works with our Medium and Heavy Duty Extruded Pushers.</p> <p>3-1/8"W x 4-1/2"H HDPADDLE</p>	
	<h3>Extra Wide Paddle</h3> <p>This paddle works in combination with both our Multi-Use and regular Pushers creating a variety of solutions for your merchandising needs. Ideal for pushing bagged salad or wide products.</p> <p>4-1/2" W x 4" H XDPADDLE</p>	

FRAME HOLDERS

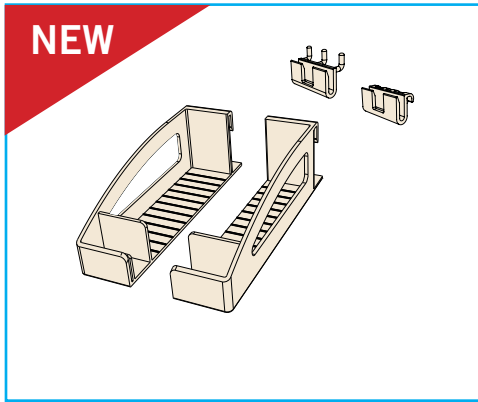

Slatwall / Pegboard and Wire Shelf Frame Holder

Linens, books, picture frames and more...these shelves hold a variety of merchandise. Position the left and right sides to suit your product. Add an optional Insert Shelf for larger products and volume. Inside shelf depth is 9-1/2". Set include left and right sides along with 2 mounting bracket for either slatwall/pegboard or wire shelf. Please specify mounting bracket when ordering.

Slatwall Set SHEFR001

*Hardware sold separately.

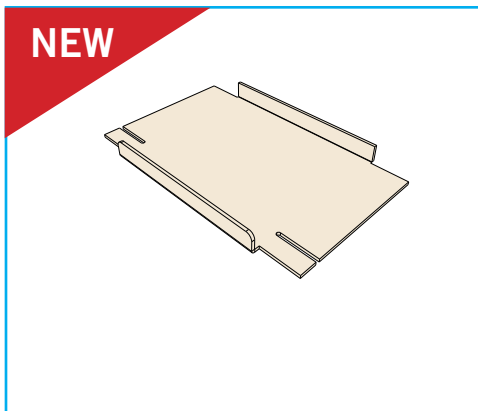

Insert Shelf

Use in conjunction with our Slatwall and Pegboard Wire Shelf Frame Holders to create a clear acrylic floating shelf.

11-1/2" W x 9-3/4" D SHEBAS001

15-1/2" W x 9-3/4" D SHEBAS002

23-1/2" W x 9-3/4" D SHEBAS003

47-1/2" W x 9-3/4" D SHEBAS004

*Custom Sizes Available



HOOK PUSHERS

OUR SNAP-ON HOOK PUSHER ATTACHES TO YOUR EXISTING WIRE PEG HOOKS MAKES FRONT FACING EASY!

HOW DOES IT WORK?

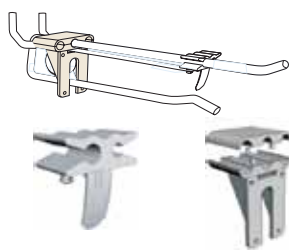

Single Hook Snap-On Pusher US Patent #7566037B2

Fits most medium and heavy duty single hooks. Spring weight is subject to products being pushed. Call us for details!

PSH0010

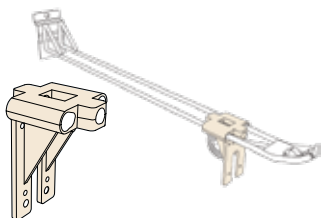

Loop Hook Snap-On Pusher

US Patent #7566037B2

Fits most medium and heavy duty double hooks. Spring weight is subject to products being pushed. Call us for details!

PLH011

CD / DVD PUSHER

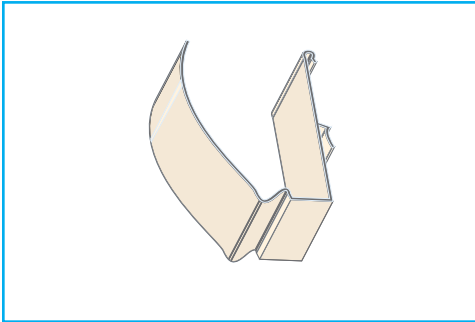

Extruded CD / DVD / Video Game Pusher

Mounts to wire, corrugate and plastic. Ideal for CD's, DVD's and video games.

SHE2325

*Available in black.

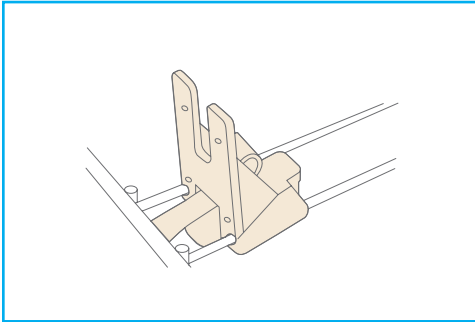
Wire Shelf Snap-On Pusher

Our Wire Shelf Snap-On Pushers keeps products front faced.

HKPSHAB



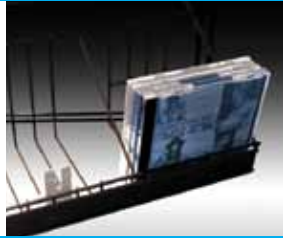
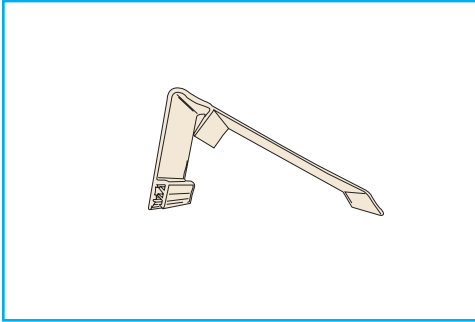



Versa Pusher Clip

Clips onto almost any flat edge. Pushes light weight products to keep them visible at all times. Manufactured in clear PVC.

SHE2796CLEAR

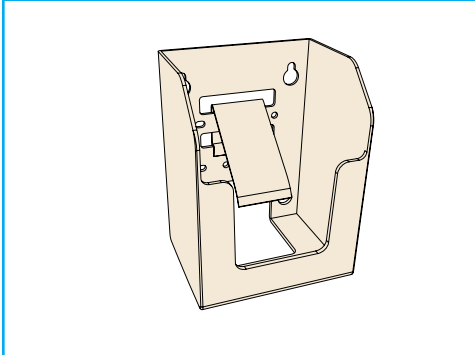
*Various lengths available.

DVD / Video Games Pusher Box

Front loading pusher allows DVD's/Video Games to be neat and visible at all times. Molded in crystal styrene. Mounting options include suction cup, shelf, pegboard and slatwall. 6 DVD capacity.

5-25/32"W x 7-11/16"H DVDB100



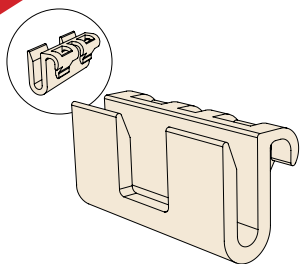

NEW

Wire / Flat Fence Clear U-Hook

Used to hang items from a wire or flat fence.

2-1/4" W

PEG006

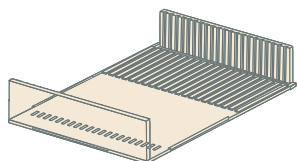

Shelf Management Mat

Individual sections connect along the sides to extend to any shelf width. Each section is 11-7/16" wide.

10" Deep

SHETRA-10CL

12" Deep

SHETRA-12CL

14" Deep

SHETRA-14CL

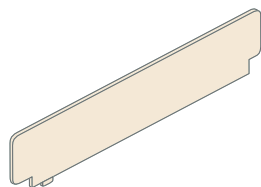

Shelf Management Mat Dividers

Dividers measure 2" high. Available in 3 lengths.

2"H x 10"L

SHEDIV2-10CL

2"H x 12"L

SHEDIV2-12CL

2"H x 14"L

SHEDIV2-14CL

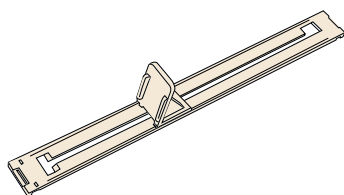

Light Duty Pusher 7/8" Wide

To be used with the Marketing Impact Limited Cosmetic Tray and Shelf Management Mat.

8" Long Pusher

LP08

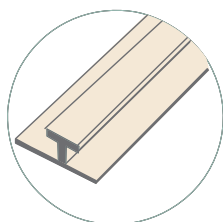

T-Snap with Foam Tape

Affix to the front and rear of Shelf Management Mat.

48"W x 3/16"H x 9/16"D

SHE2758

POPULAR SHELF PUSHER KITS

GIVE YOUR SALES A PUSH!

Our pusher kits provide an effortless solution for complete shelf merchandising. Just add your product! Made from high-impact styrene, our pusher kits fit any shelving system and are maintenance free!

- * Shelf depths can be customized upon request to fit your various shelf requirements.
- * Kits can be customized to various shelf widths.



Deodorant Pusher Kit - 16" Deep

- Kit Includes:**
 17 - Light Duty Pushers
 18 - White Dividers
 1 - 1-1/4" Clear Front Fence
 1 - Basic Rail

Deodorant Pusher Kit

DEODORANTSHELF

*Available in 10"- 16" Depths.

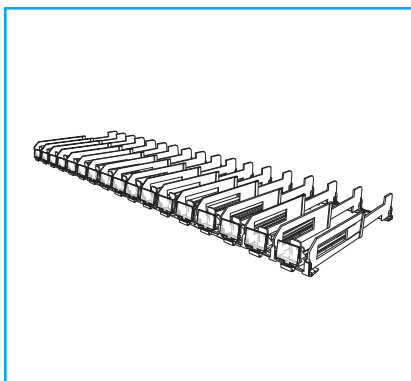

Fold N Load™ 14" Deep Light Duty Pusher Kit for Pharmacy Products

- Kit Includes:**
 17 - Light Duty Pushers (With Fold N Load™ Clear Fronts)
 18 - White Dividers
 2 - Basic Rails

Fold N Load™ 14" Deep

SHELFSYS416C14

*Available in 12", 14" and 16" Depths.

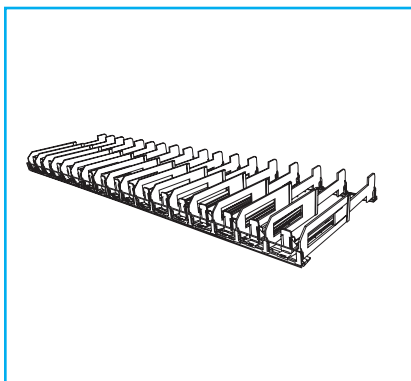

Pharmacy Pusher Kit - 14" Deep

- Kit Includes:**
 17 - Light Duty Pushers
 18 - White Dividers
 1 - 1-1/4" Clear Front Fence
 1 - Basic Rail

Pharmacy Pusher Kit

SHELFSYS414C14



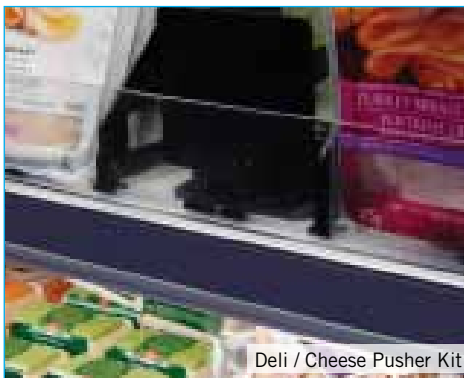

Deli / Cheese Pusher Kit



Produce Pusher Kit



Shelf Mounted Bottle Pusher Kit

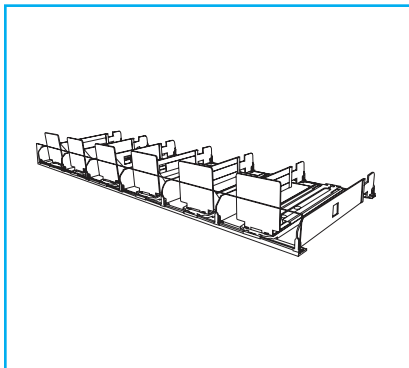

Deli / Cheese Pusher Kit - 14" Deep

Kit Includes:

- 6 - Pushers with Extra Large Paddles
- 7 - Dividers
- 1 - 3" Clear Front Fence
- 1 - Basic Rail

Deli Pusher Kit DELIPUSHSYS46P14

Cheese Pusher Kit CHEESEPUSHSYS46P15

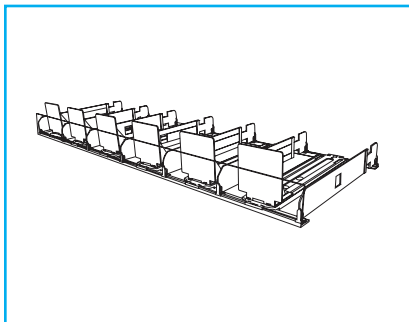

Produce Pusher Kit - 16" Deep

Kit Includes:

- 6 - Pushers with Extra Large Paddles
- 7 - Dividers
- 1 - 3" Clear Front Fence
- 1 - Basic Rail

Produce Pusher Kit PUSHSYS417P1

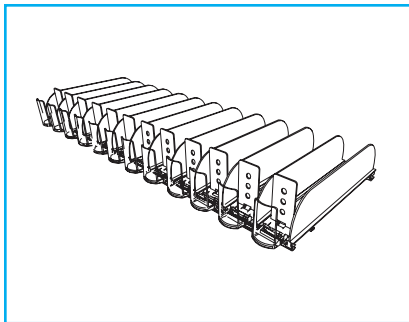

Shelf Mounted Bottle Pusher Kit - 16" Deep

500ml and 1L Bottle Kit Includes:

- 14 - Pushers with Bottle Fronts
- 15 - Dividers
- 2 - Basic Rails

500ml/1L Pusher Kit SHELFBOT406

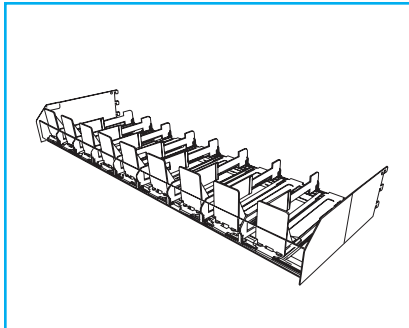

DVD / Video Game Pusher Kit

Mounts directly to store uprights.

Kit Includes:

- 8 - Heavy Duty Pushers
- 7 - Dividers (4" high)
- 1 - Metal Hanging Shelf
- 1 - Basic Snap Rail

Kit fits 48" wide and 16" deep shelves. SHELFDVD408W16



KWICKLOAD™ PUSHER SYSTEM

GIVE YOUR SALES A PUSH!

The Kwickload™ Pusher System is Marketing Impact Limited's New and innovative addition to the pusher family. It's sleek and visually minimal design is ideal for pushing bagged salad, packaged cheese and packaged deli meats.

U.S. & Canadian Patent Pending



Available in lengths of: 16" / 40.5 cm, 18" / 46 cm, 20" x 51 cm, 22 / 56 cm

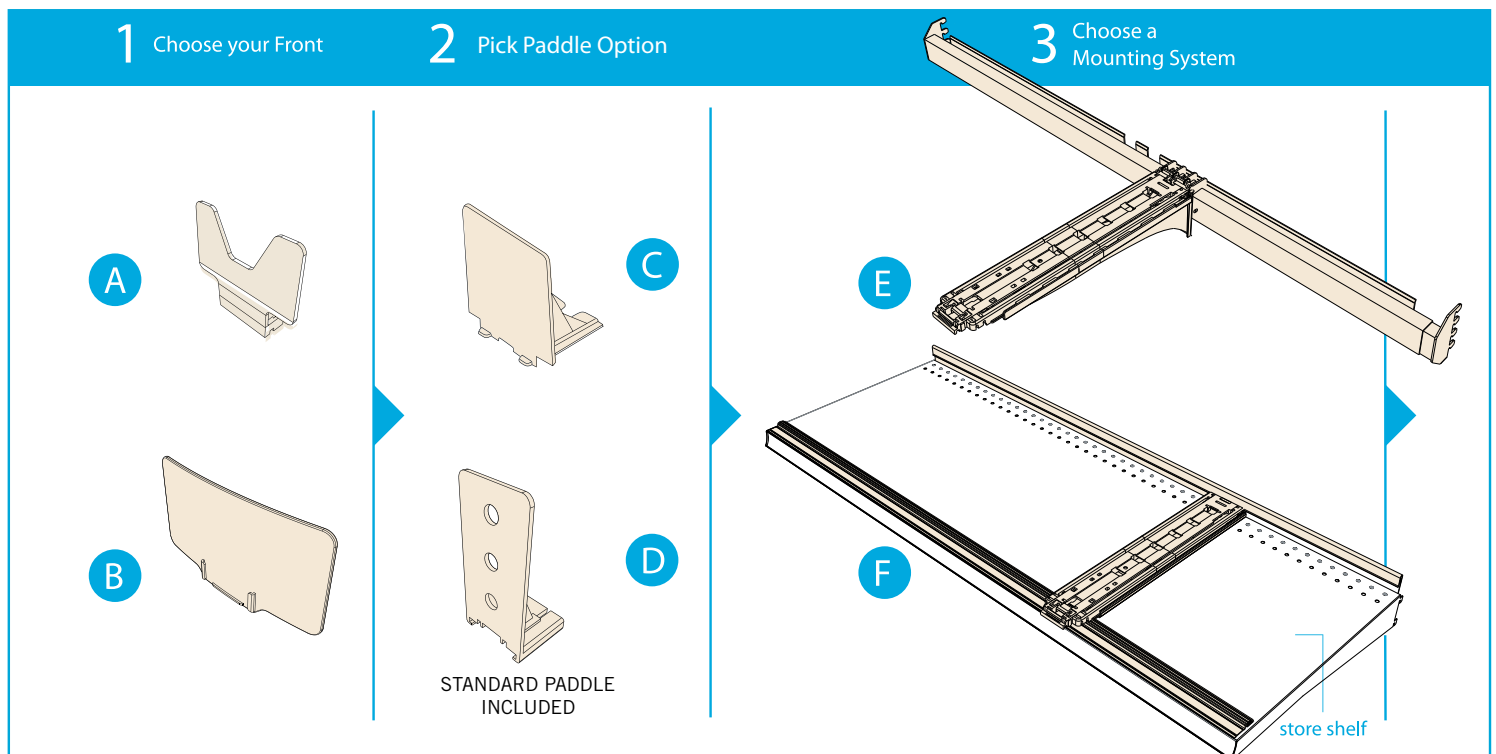

Features & Benefits

- Revolutionary slide out mechanism allows for no hassle one handed reload
- Allows for easy stock rotation
- Paddle remains locked in place for easy product loading
- Multiple mounting options include standard cross bar and pegboard
- Available in different sizes to accommodate a variety of products
- Heavy duty construction ensures durability and reliability, even in the cold
- Patent Pending



LEGEND

- | | | |
|------------------------------|--------------------------------|------------------------------|
| A Pusher Clear Front | E Crossbar Mount Kit | I Support Bar |
| B Pusher Curved Front | F Shelf Mount Plate Kit | J Shelf Cooler Baffle |
| C Extra Wide Paddle | G Moulded Dividers | K Individual Baffle |
| D Standard Paddle | H Wire Dividers | |

4 Choose a Divider

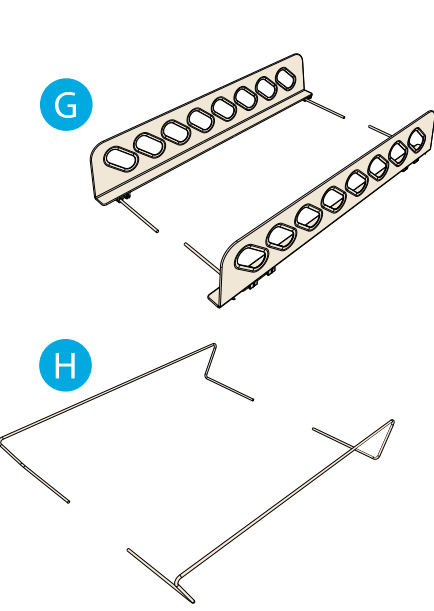

5 Optional Add-Ons

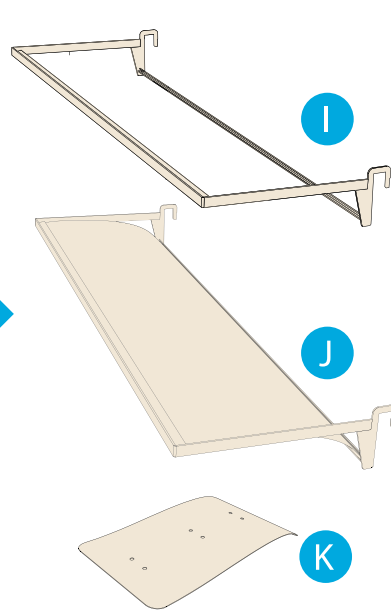

SETUP

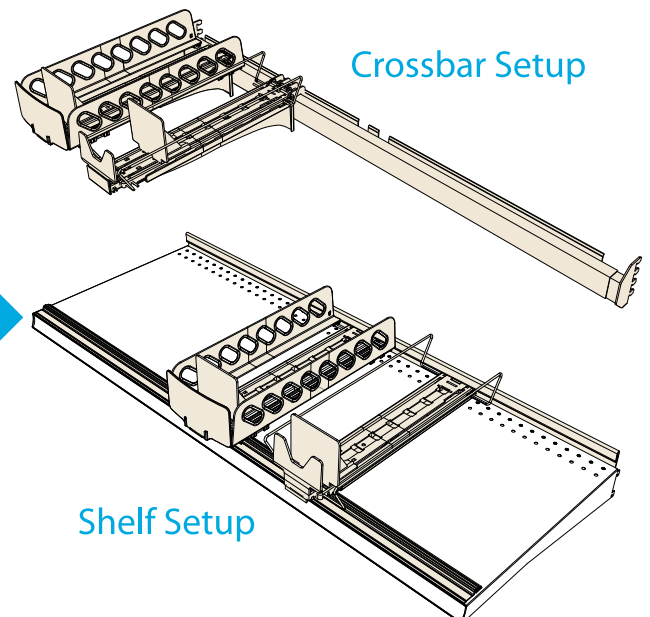

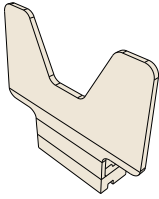
NEW

Pusher Clear Front

Clear Front Plate can be attached to our Multi-Use Heavy and Medium Duty Pusher Systems. Manufactured in clear polycarbonate.

3-3/4" W x 4-1/2" H

CLRFRT001

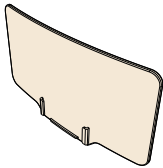
NEW

Pusher Curved Front

The Pusher Curved Front can be attached to our Multi-Use Heavy Duty, Multi-Use Medium Duty, and Kwickload™ Pusher Systems. Ideal for bagged product. Manufactured in clear polycarbonate.

6-1/2" W x 4" H

CLRFRT007

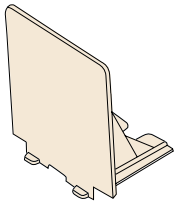

Extra Wide Paddle

This paddle works in combination with both our Multi-Use and regular Pushers creating a variety of solutions for your merchandising needs. Ideal for pushing bagged salad or wide products.

4-1/2" W x 4" H

XDPADDLE

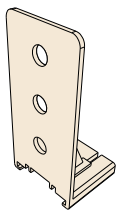

Medium Duty Paddle

A widely used and common product that works with a multitude of MIL's track systems.

2-3/8" W x 4-1/2" H

WHPADDLE

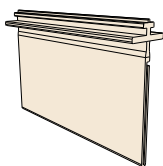
NEW

Kwickload™ Pivoting Label Holder

Clear PVC snaps on base track on Pusher System.

1-1/4" H

SHF0368CLEAR

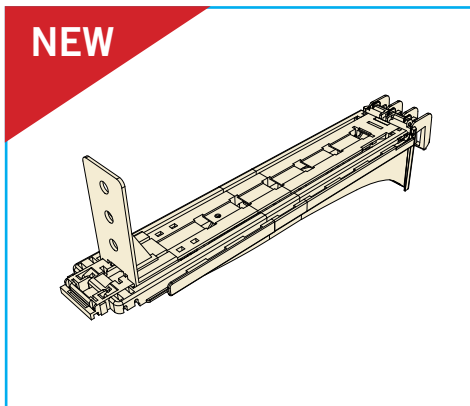

Kwickload™ Crossbar Mount Kit

The Crossbar Mount works in conjunction with MIL's Adjustable Crossbar, and Kwickload™ Track. Robust design ensures durability and reliability even when used for freezer merchandising. Injection moulded in ABS.

16"	KLMCM16
18"	KLMCM18
20"	KLMCM20
22"	KLMCM22

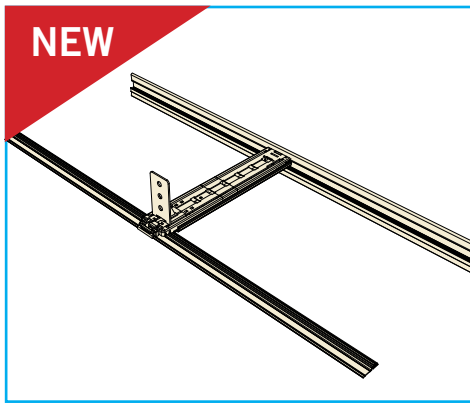

Kwickload™ Shelf Mount Plate Kit

The Shelf Mount Plate allows MIL's Kwickload™ Tracks to be mounted to an existing store shelf. Enables the Kwickload™ Track to be pulled forward for quick loading and product rotation. Manufactured in stainless steel.

For 16"-18" Tracks	KLA001
For 20"-22" Tracks	KLA002

*Available in black.

NEW

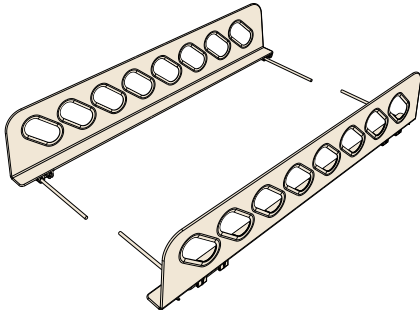

Moulded Dividers

Ideal for merchandising larger items such as bagged salad or pasta. Dividers adjust from 5" to 9" wide. Select the appropriate length to match your Kwickload™ Track. Injection moulded in high impact styrene.

16" L X 3-1/2" H	MWIRE16B
18" L X 3-1/2" H	MWIRE18B
20" L X 3-1/2" H	MWIRE20B
22" L X 3-1/2" H	MWIRE22B

*Available in black.

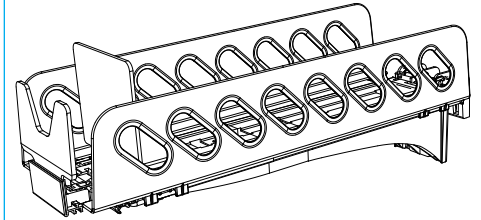

NEW

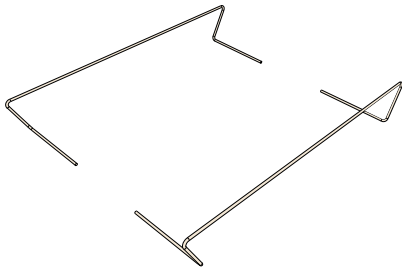

Wire Dividers

Ideal for merchandising smaller items such as candy and deli meats. Dividers are adjustable from 4" to 11" wide. Select the appropriate length to match your Kwickload™ Track.

16" L X 3-1/2" H	WIRE16B
18" L X 3-1/2" H	WIRE18B
20" L X 3-1/2" H	WIRE20B
22" L X 3-1/2" H	WIRE22B

*Available in black.

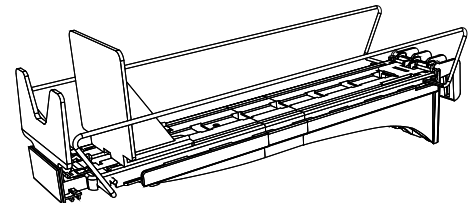

NEW

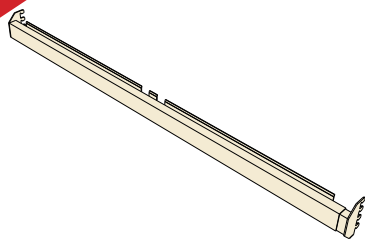

Adjustable Crossbar

Designed to mount directly into gondola uprights. Easy to install, the Adjustable Crossbar will adjust to fit 46-1/2" to 48" centers. This item is a required component for the Kwickload™ Crossbar Mount, Support Bar, Shelf Freezer Baffle, Hook Bar C-Clamp, and Deli Shelf. Manufactured in steel.

CROBAR

*Available in black.

NEW

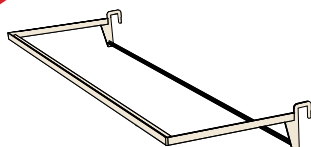

Support Bar

A recommended item when using 20" and 22" Crossbar. The Support Bar easily fits onto the Adjustable Crossbar.

SUPBAR

SHELF COOLER BAFFLE / SUPPORT BAR

HOW DOES IT WORK?

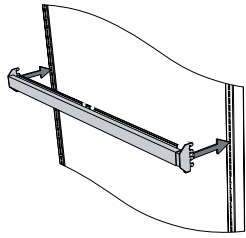

Affix Adjustable Crossbar to shelf uprights

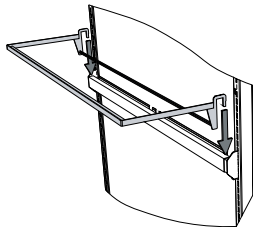

Attach Kwickload™ Cooler Baffle Frame to Adjustable Crossbar

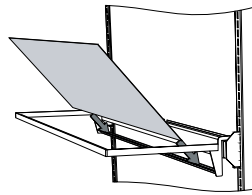

Add Kwickload™ Cooler Baffle to Baffle Frame

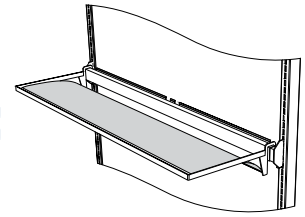

NEW

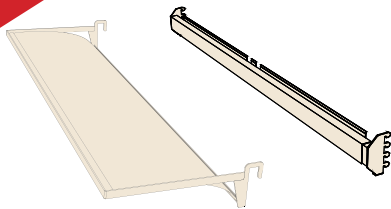

SHELF COOLER BAFFLE / SUPPORT BAR

The Shelf Cooler Baffle redirects cool air forward in order to provide consistent and even cooling of the front most products. The Shelf Cooler Baffle easily mounts onto the Adjustable Crossbar. Steel frame with a high density polyethylene insert.

Kit Includes
Baffle Support Bar
Baffle
Adjustable Crossbar

BAFSUPSET

KWICKLOAD™ COOLER BAFFLE

NEW

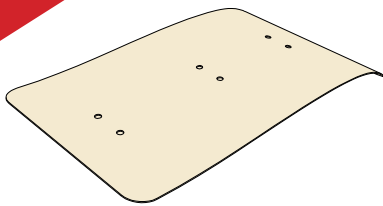

Kwickload™ COOLER BAFFLE

15"	BAFFLE08015
17"	BAFFLE08017
19"	BAFFLE08019
21"	BAFFLE08021



NEW

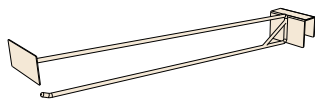

Hook Bar C-Clamp with Label Plate

Constructed from 1/4" steel wire, and designed with heavier products in mind such as deli meats. Mounts onto MIL's Adjustable Crossbar.

18" L

HKBARC001

*Available in black.
**Custom sizes available. Minimum quantities apply.

NEW

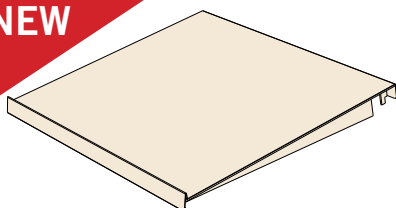

Metal Deli Meat Shelf

Heavy duty construction, designed to mount onto MIL's Adjustable Crossbar.

SHLFMET001

*Available in black.
**Custom sizes available. Minimum quantities apply.

HANGING / SHELF MOUNTED PUSHER SYSTEM



Features & Benefits

- Perfect for Oral Hygiene Products
- Specially designed Light Duty pusher tracks and paddles keep products cleanly faced
- A revolutionary alternative to hooks!



Pegboard Mount Light Duty Pusher System.
U.S. & Canadian Patent Pending

HOW DOES IT WORK?

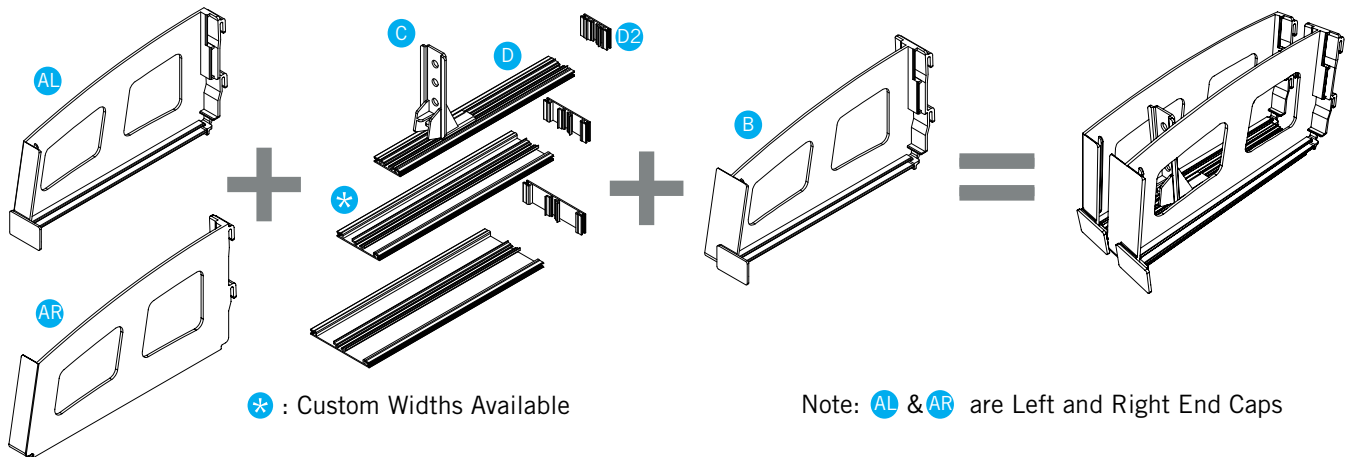

LEGEND

- | | | | |
|----|---------------------------|----|---------------------------------------|
| AL | Left Divider - DIVL0112C | C | Tall Light Duty Paddle - TLDPADDLEANG |
| AR | Right Divider - DIVR0112C | D | Pusher Track - SHF033CLEAR |
| B | T-Divider - DIVT0212C | D2 | Rear Support Clip - SHF335CLEAR |

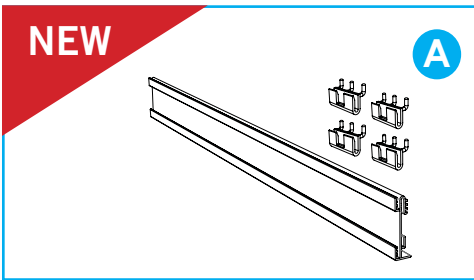
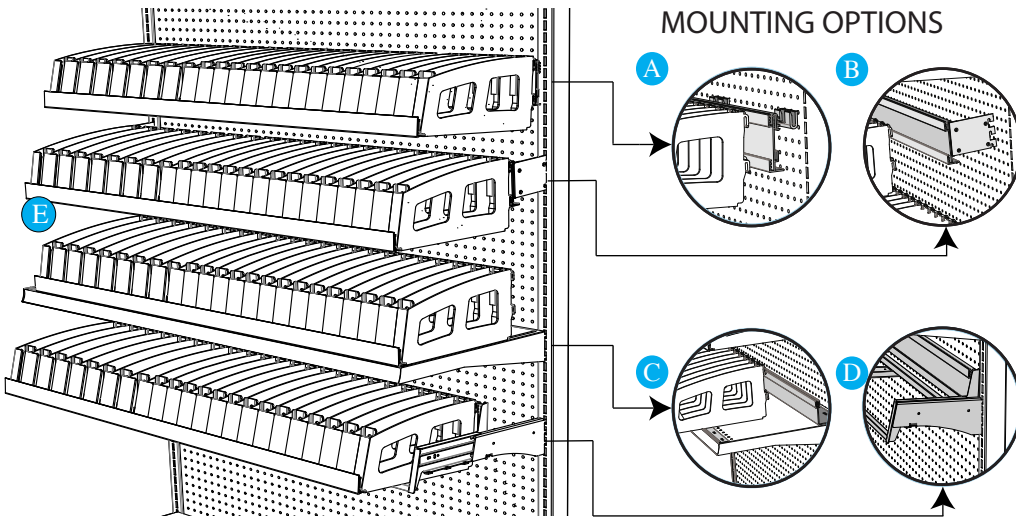

NEW

A Pegboard Mounting Kit

4' wide with 24 facings – Kit Includes:
 1 - Divider Back 1 - Left Divider 1 - Right Divider 22 - Center T
 24 - Light Duty Tall Paddle / Front with Angle and Spring 4 - Peg Clear U-Hook

Upright Light Duty Pusher System PEGMOU0424

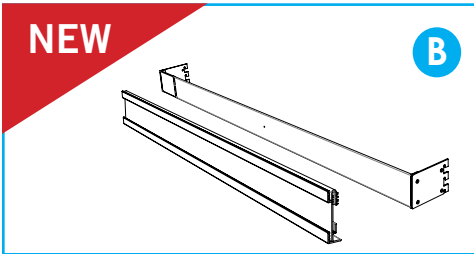

NEW

B Upright Mounting Kit

4' wide with 24 facings – Kit Includes:
 1 - Divider Back 1 - Left Divider 1 - Right Divider 22 - Center T
 24 - Light Duty Tall Paddle / Front with Angle and Spring 1 - Metal Mount Bar

Pegboard Mounted Light Duty Pusher System UPRMOU0424

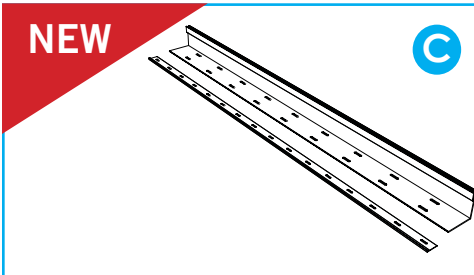

NEW

C Shelf Mounting Kit

4' wide with 24 facings – Kit Includes:
 1 - Divider Back 1 - Left Divider 1 - Right Divider 22 - Center T
 24 - Light Duty Tall Paddle / Front with Angle and Spring 1 - Front Track 1 - Back Track

Shelf Mounted Light Duty Pusher System SHEMOU0424

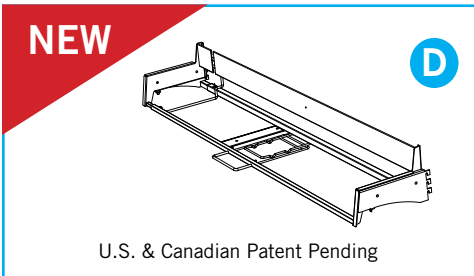

NEW

D Pull Out Adjustable Crossbar Mounting Kit

4' wide with 24 facings – Kit Includes:
 1 - Divider Back 1 - Left Divider 1 - Right Divider 22 - Center T
 24 - Light Duty Tall Paddle / Front with Angle and Spring 1 - Front Track 1 - Pull Out Adjustable Cross Bar

Upright Light Duty Pusher System PULMOU0424

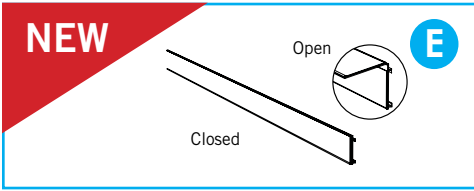

NEW

E Flip Data Strip

Flip Data Strip (1-1/2"H x 47-7/8"W) SHE0282WHITE/CL

EXTRUDED GRAVITY FEED / PUSHER SYSTEM

System can be easily converted to Front Facing Merchandising by adding Pushers and Springs

Slide and Divide Features & Benefits

- Create custom track lengths
- Low friction extruded PVC track allow products to glide smoothly
- System is fully compatible with all fences and fronts from our modular pusher systems

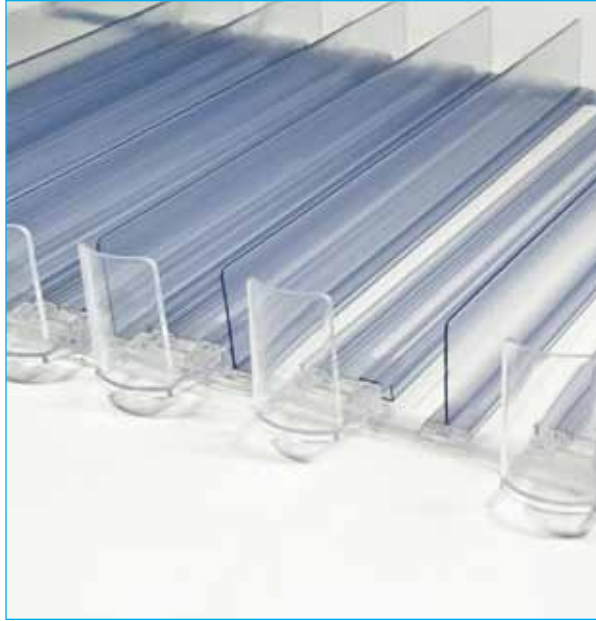

HOW DOES IT WORK?

1. Choose a Front

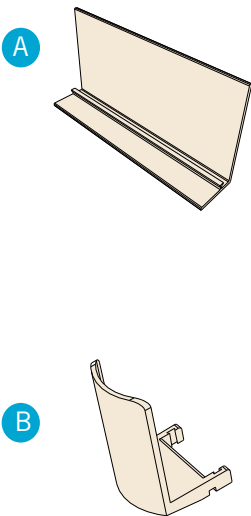

2. Choose a Track (Custom Length)

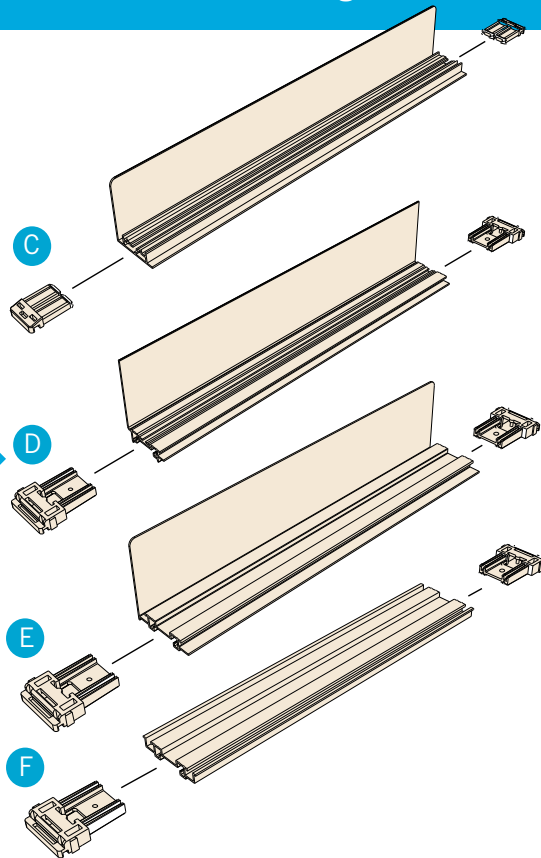

3. Add a Divider or End Cap

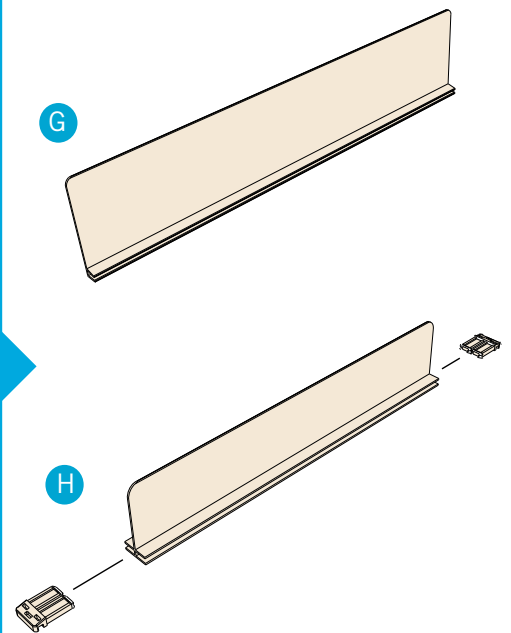



Our new slide and divide merchandising system is beyond the scope of the traditional gliding racks in the market today. Our system employs cost effective extrusion technology incorporated with minimal injection molding to create a fully modular gliding system. Each track incorporates a divider wall and is composed of durable plastics which can be extruded to any length. The width is customizable with new extrusions, which are considerably more cost effective than injection molding a complete tray. Finally, each track is fully compatible with MIL's pusher systems giving the new system that ability to push the beverage to the front of the line in sales.

4. Choose a Paddle for Pusher System or Custom Wedge for Gravity Slide System

Examples of Pusher and Gravity Slide Systems

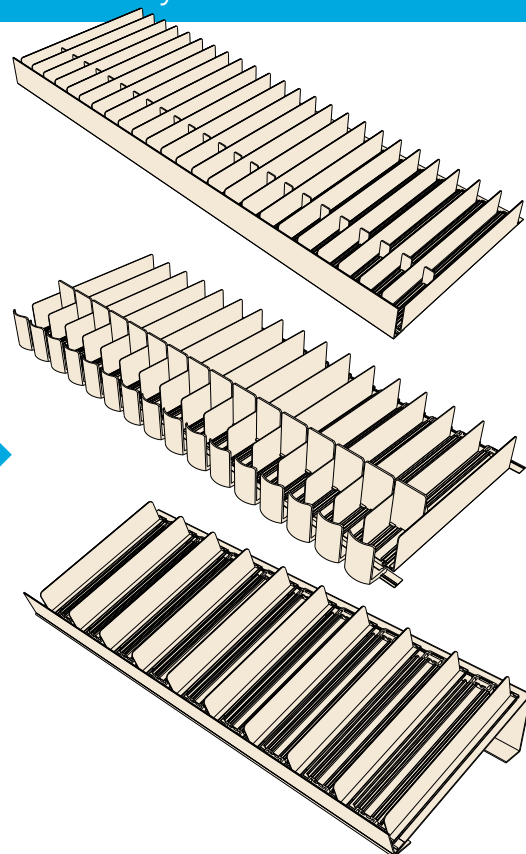
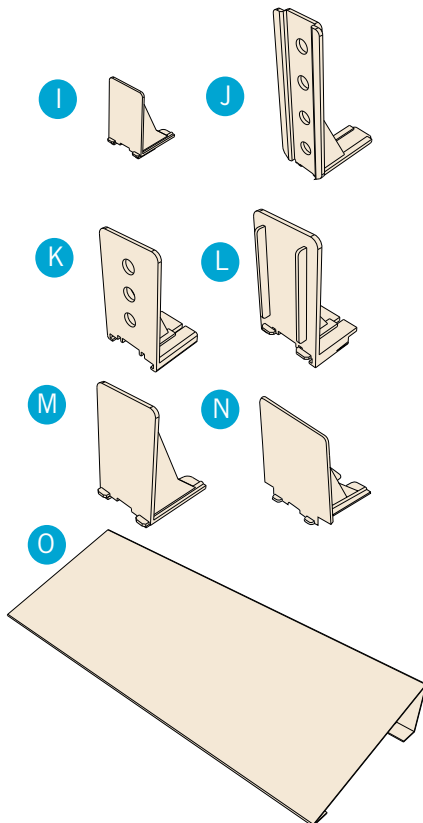

LEGEND

- A** Clear Front Fence
- B** Pusher Bottle Front
- C** Light Duty Extruded Track and Divider
- D** Medium Duty Extruded Track and Divider
- E** Heavy Duty Extruded Track and Divider
- F** Heavy Duty Extruded Track
- G** Extruded End Cap
- H** Extruded Divider
- I** Light Duty Paddle
- J** Light Duty Paddle Straight
- K** Medium Duty Paddle
- L** Medium Duty Paddle with Ridges
- M** Heavy Duty Paddle
- N** Extra Wide Paddle
- O** Custom Gravity Wedge

NEW

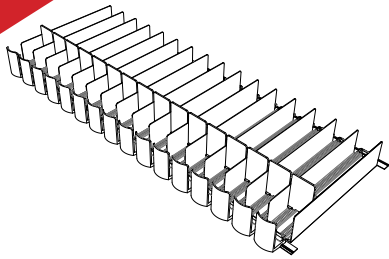

Drink System - 16" Deep

Pusher Kit Includes:

- 16 - 16" Deep Pushers with Springs
- 17 - Bottle Fronts
- 1 - End Divider
- 2 - Basic Rails 4'L

Gravity Kit Includes:

- 17 - Bottle Fronts
- 1 - End Divider
- 2 - Basic Rails 4'L
- 17 - Heavy Duty Track Dividers

HSLP416C

HSL417C

NEW

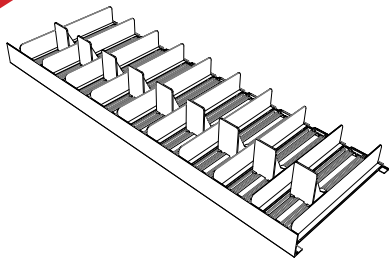

Condiment System - 16" Deep

Pusher Kit Includes:

- 9 - 16" Deep Pushers with Springs
- 1 - 3" H Clear Fence
- 1 - Back Rail
- 1 - End Divider
- 2 - Basic Rails 4'L

Gravity Kit Includes:

- 1 - 3" H Clear Fence
- 1 - Back Rail
- 1 - End Divider
- 10 - Medium Duty Extrude Track Dividers

MSLP409C

HSL410C

NEW

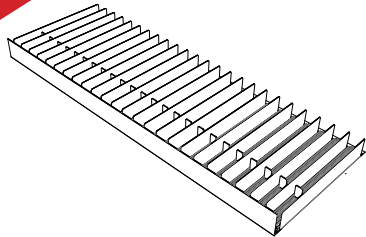

Spice System - 16" Deep

Pusher Kit Includes

- 24 - 16" Deep Pushers with Springs
- 1 - 1-1/4" H Clear Fence
- 1 - Back Rail 4'L
- 1 - End Divider

Gravity Kit Includes

- 1 - 1-1/4" H Clear Fence
- 1 - Back Rail 4'L
- 1 - End Divider
- 17 - Heavy Duty Track Dividers

L5LP424C

L5L425C



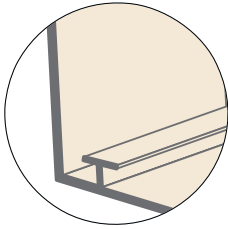

Clear Front Fence

Affix to the front of a shelf. Can be used with Marketing Impact Limited Pushers and Dividers.

47-7/8"W x 1-1/4"H with Holes	CLEARFENCE148
47-7/8"W x 2"H	CLEARFENCE248
47-7/8"W x 2-1/2"H	CLEARFENCE2548
47-7/8"W x 3"H	CLEARFENCE348

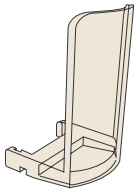

Pusher Bottle Front

The Bottle Front can be attached to our Multi-Use Heavy and Medium Duty Pusher Systems. Manufactured in clear polycarbonate.

2-3/8" W x 3-7/8" H	BTNFRONT
---------------------	----------

NEW

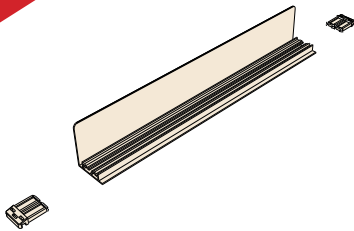

Light Duty Extruded Track and Divider

Low cost, low friction, and fully customizable our Extruded Tracks can be used for either a Pusher or Gravity Slide System. Each custom track length comes complete with Small Adaptors for secure fastening to your store shelf. Ideal for pushing or sliding small, lightweight products such as spices. Manufactured from extruded clear PVC.

1-3/4"W x 2-1/4"H	SHE0438
-------------------	---------

*Please specify Track length upon ordering.
**Custom sizes and colors available. Minimum quantities apply.

NEW

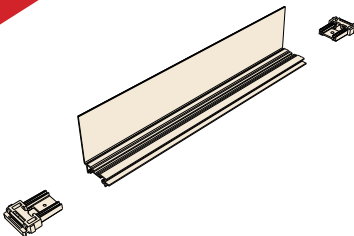

Medium Duty Extruded Track and Divider

Low cost, low friction, and fully customizable our Extruded Tracks can be used for either a Pusher or Gravity Slide System. Each custom track length comes complete with Large Adaptors for secure fastening to your store shelf. Ideal for pushing or sliding pharmacy products. Manufactured from extruded clear PVC.

2-1/4"W x 3-1/2"H	SHE0494
-------------------	---------

*Please specify Track length upon ordering.
**Custom sizes and colors available. Minimum quantities apply.

NEW

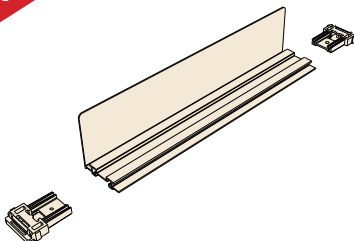

Heavy Duty Extruded Track and Divider

Low cost, low friction, and fully customizable our Extruded Tracks can be used for either a Pusher or Gravity Slide System. Each custom track length comes complete with Large Adaptors for secure fastening to your store shelf. Ideal for pushing or sliding beverages. Manufactured from extruded clear PVC.

2-3/4"W x 3-1/4"H	SHF0365
-------------------	---------

*Please specify Track length upon ordering.
**Custom sizes and colors available. Minimum quantities apply.

NEW

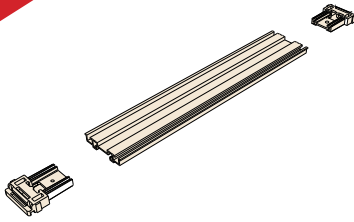

Heavy Duty Extruded Track

Low cost, low friction, and fully customizable our Extruded Tracks can be used for either a Pusher or Gravity Slide System. Each custom track length comes complete with Large Adaptors for secure fastening to your store shelf. Add our Extruded T Dividers in between each track at a width to fit your product. Manufactured from extruded clear PVC.

2-3/4"W

SHF0380

*Please specify Track length upon ordering.
**Custom sizes and colors available. Minimum quantities apply.

NEW

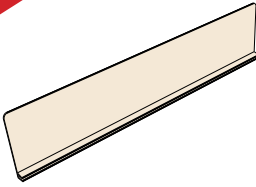

Extruded End Cap

Complete your Light/Medium/Heavy Duty Extruded Track and Divider system with an Extruded Divider. Manufactured from extruded clear PVC

SHF0725

*Please specify lengths upon ordering.
**Custom sizes and colors available. Minimum quantities apply.

NEW

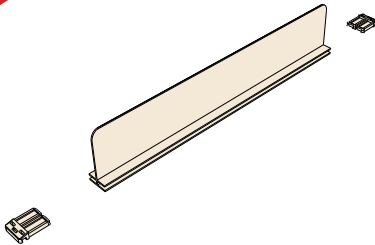

Extruded Divider

Use in conjunction with MIL's Heavy Duty Extruded Track to conform to whatever width your product may be. Each custom length Divider comes complete with Small Adaptors for secure fastening to your store shelf. Manufactured from extruded clear PVC.

Light Duty: 2-1/4"H

SHF0369

Medium Duty: 3-1/2"H

SHF0369M

Heavy Duty: 3-1/4"H

SHF0369H

*Please specify lengths upon ordering.
**Custom sizes and colors available. Minimum quantities apply.

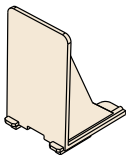

Light Duty Paddle

This Paddle works with our Light/Medium Duty Slide and Divide Tracks.

7/8"W x 1-1/2"H

LDPADDLE

NEW

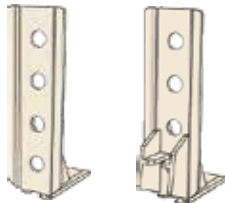

Tall Light Duty Paddle

This paddle works with our Light / Duty Slide and Divide Tracks.

1-5/8"W x 4-1/2"H

TLDPADDLE

1-5/8"W x 4-1/2"H

TLDPADDLEANG

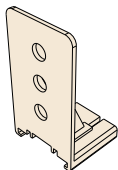

Medium Duty Paddle

This Paddle works with our Heavy Duty Slide and Divide Tracks.

2-3/8"W x 4-1/2"H

WHDPADDLE

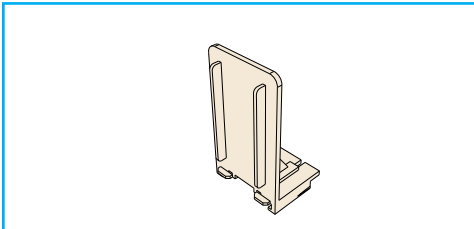

Medium Duty Paddle with Ridges

This Paddle works with our Heavy Duty Slide and Divide Tracks.

2-3/8"W x 4"H

MDPADDLE

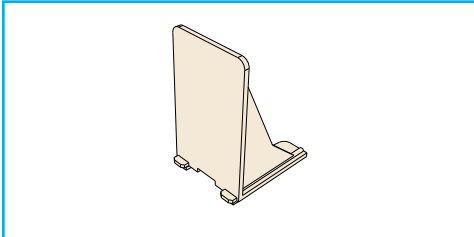

Heavy Duty Paddle

This Paddle works with our Heavy Duty Slide and Divide Tracks.

3-1/8"W x 4-1/2"H

HDPADDLE

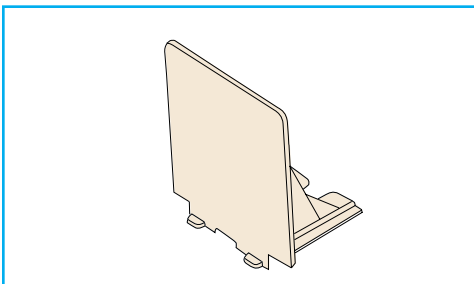

Extra Wide Paddle

This paddle works in combination with both our Slide and Divide and regular Pushers creating a variety of solutions. Ideal for pushing bagged salad or wide products.

4-1/2" W x 4" H

XDPADDLE

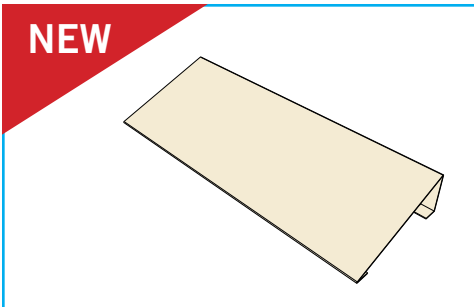

NEW

Custom Gravity Wedge

MIL's Custom Gravity Wedge is built to suit your custom Slide and Divide Gravity System. Turns a flat shelf into an angled shelf. Please specify size upon ordering. Fabricated from expanded PVC.

WEDGE001

*Available in white.
**Custom colors available. Minimum quantities apply.

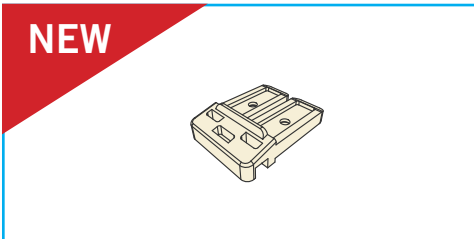

NEW

Small Adapter Clips

For use with our Medium and Heavy Duty Tracks.

ADAEPS001

Moulded in clear polycarbonate.

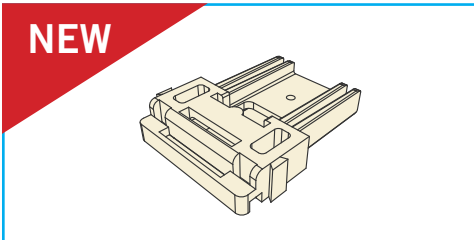

NEW

Large Adapter Clips

For use with our Medium and Heavy Duty Tracks.

ADAEPL001

Moulded in clear polycarbonate.

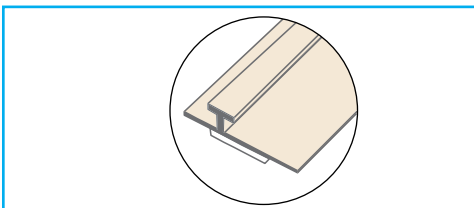

Rear T-Snap

Affix to the front or rear of a shelf to support Pushers and Dividers.

47-7/8"L x 3/16"H x 1-1/8"D with Tape

SA127DTAPE

COOLER MERCHANDISING

TOP SHELF

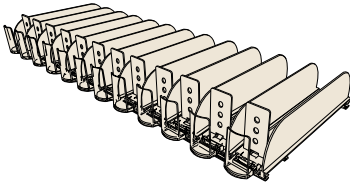

Shelf Mounted Bottle Pusher Kit

2ND SHELF

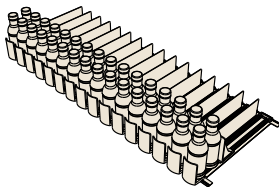

Drink System Gravity Kit

3RD AND 4TH SHELF

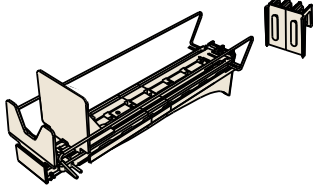

Crossbar Kwickload™ Pusher System

BOTTOM SHELF

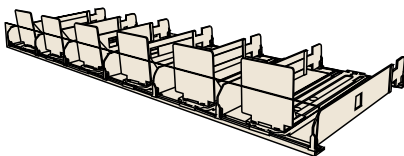

Produce Pusher Kit - 16" Deep



SECURITY LOSS



SECURITY / LOSS PREVENTION

Innovative Loss Prevention Solutions Tailored To Meet Your Needs!

 **marketingIMPACT**
LIMITED

displaypeople.com

SECURITY PUSHER SYSTEM



HOW DOES IT WORK?

Modular Merchandising Security System

DETERMINE WHAT YOUR NEEDS ARE BY ANSWERING THESE QUESTIONS

- 1) What is the width of your shelf?
- 2) What is the depth of your shelf?
- 3) What is the weight of the product you are pushing and how many items in a row? This will allow us to determine the weight of the spring you require.
- 4) What is the width and height of your product? This will allow us to determine the size of the pusher you require.
- 5) Do you require a security door on your shelf system?
- 6) Do you require a slide mechanism on your shelf?

CHOOSE FROM 6 STYLES OF PUSHERS:

1- Light Duty Pusher

7/8" Wide x 1 1/8" High to push product similar to deodorant.

2- Medium Duty Pusher

2 3/8" Wide x 4 1/4" High to push product similar to candy.

3- Heavy Duty Pusher

3 1/4" Wide x 4 1/2" High to push product similar to shavers.

4- Extra Wide Pusher

4 1/2" Wide x 4 1/2" High to push product similar to salad.

5- Multi-Use Medium Duty Pusher

2 3/8" Wide x 5" High to push product similar to bagged candy.

6- Multi-Use Heavy Duty Pusher

3 3/8" Wide x 5 1/8" High to push product similar to bottled beverages.

THE MAXIMUM NUMBER OF PUSHERS PER SHELF WIDTH IS AS FOLLOWS:

36" Wide Shelf Maximum Capacity

LP - 18 Pushers
 MP - 11 Pushers
 HP - 8 Pushers
 XD - 7 Pushers
 MCMP - 10 Pushers
 CMP - 8 Pushers

48" Wide Shelf Maximum Capacity

LP - 24 Pushers
 MP - 15 Pushers
 HP - 11 Pushers
 XD - 7 Pushers
 MCMP - 14 Pushers
 CMP - 12 Pushers

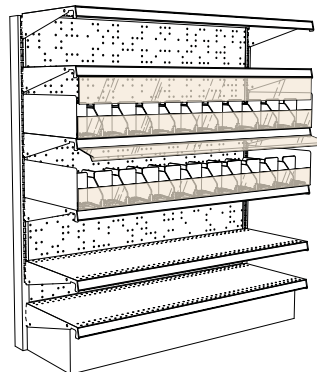
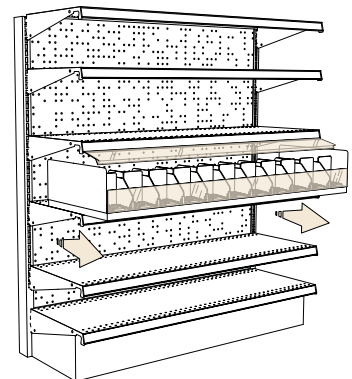
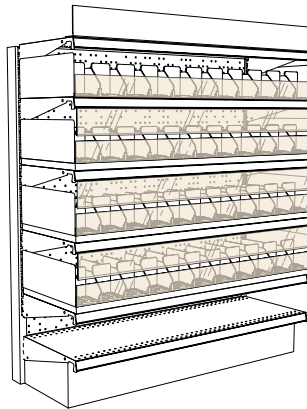

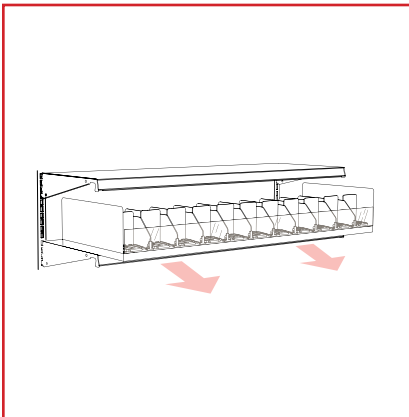

Pull-Out Shelf Pusher Kit with Slide Mechanism

Fits standard store shelf widths and depths. Complete system with slide mount for easy merchandising.

Kit Includes:

- 11 - Heavy Duty Pusher
- 10 - Dividers
- 1 - 3" Front Fence (48"L)
- 2 - Metal Side Gables Mounted to a 48" Sliding Metal Shelf
- 1 - Basic Snap Rail

Pull-Out Shelf Pusher Kit w/ Slide Mech. CARTSLIDESHELF

*Fits 16" deep shelves.

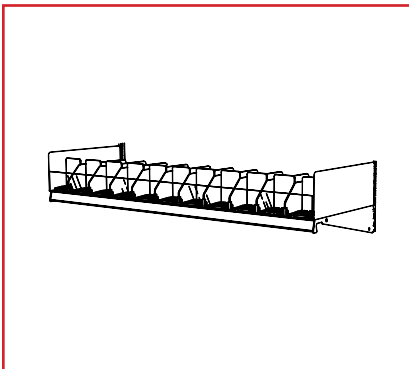

Shelf Pusher Kit

Kit Includes:

- 11 - Heavy Duty Pushers
- 10 - White Dividers
- 2 - Metal Side Gables
- 1 - 3" Clear Front Fence
- 1 - Basic Snap Rail

Shelf Pusher Kit RAZORSHELF

*Fits standard store shelf widths and depths.

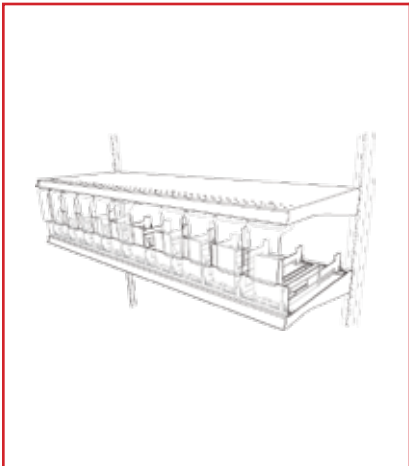

Invisi-Shield™ Standard Kit with Pushers 16" Deep

Kit includes:

- 1 - Invisi-Shield™ Hardware Kit
- 1 - Invisi-Shield™ Panel Kit (see above for sizes)
- 1 - 3" Front Fence
- 1 - Basic Snap Rail
- 10 - Dividers
- 9 - Pushers with springs

High-impact clear plastic Invisi-Shield panels are available in 4 sizes. Please specify desired panel size when placing your order:

Invisi-Shield™ Standard Kit with Pushers INVISIKIT001

*Fits 16" deep shelves.

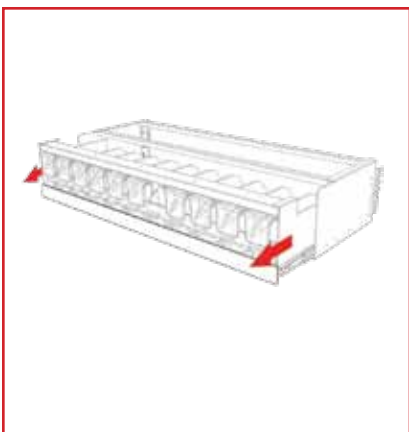

Secure Merchandiser Slide Shelf with Invisi-Shield™

Kit Includes:

- 1 - 4' Metal Slider Shelf with Metal Topper
- 1 - Front Label Holder
- 10 - Panel Sliders
- 11 - Pushers
- 10 - Dividers
- 1 - Basic Snap Rails
- 1 - 3" Front
- 1 - High Security Lock

Secure Merchandiser Shelf with Invisi-Shield™ INVISECSLI001



LOCK BOX

INNOVATIVE LOSS PREVENTION SOLUTIONS TAILORED TO MEET YOUR NEEDS!

Secure high-value and high-theft products, allowing customers to purchase only with the assistance of an associate.



Features & Benefits

- Secures high-value and high theft products
- Allows customers to only purchase with the assistance of a store associate
- Mounts directly onto store shelf
- Custom dimensions available for specific shelf widths, depths and heights
- Customized to fit various products
- Gables available in copoly or metal finish
- Lock Box available with single or double lock



Lock Box with Copoly (Double Lock) | LOCK002



Lock Box with Metal Gables (Double Lock) LOCKMG002

(Shown with Pushers and Dividers sold separately)

Suggested product ideas for this system



Lock Box

Lock Box with Metal Gables (Single Lock)	48"W x 16"D	LOCKMG001
Lock Box with Metal Gables (Double Lock)	48"W x 16"D	LOCKMG002
Lock Box with Copoly Gables (Single Lock)	48"W x 16"D	LOCK001
Lock Box with Copoly Gables (Double Lock)	48"W x 16"D	LOCK002

*Custom sizes available. Minimum quantities apply.



SECURITY FLIP DOOR

INNOVATIVE LOSS PREVENTION SOLUTIONS TAILORED TO MEET YOUR NEEDS!

Great product visibility combined with the efficiency of a theft deterrent.



Features & Benefits

- Stop sweeping
- Flip door requires 2 hands to shop
- Mounts directly onto shelves
- Customized to accommodate various products and store shelving
- Dividers slide left and right to accommodate various product widths
- System comes with a chime to alert the retailers and consumer when flip door is opened



Security Flip Door can be adjusted to different heights and accommodate various product.

Security Flip Door In-Store Setup with Adjustable Dividers.

(Shown with Gum Pusher Kit | GUMPUSH420M4HK)

Security Flip Door with Alarm

Manufactured in copoly, the Security Flip Door fits a standard shelf width of 48". Can also be used with Marketing Impact Limited Pusher Kits.

Security Flip Door with Alarm

SECURITYDOOREXT

Security Flip Door with Alarm and Lock

SECURITYDOORALM

*Custom sizes available. Minimum quantities apply.



SECURE MERCHANDISER SHELF

INNOVATIVE LOSS PREVENTION SOLUTIONS TAILORED TO MEET YOUR NEEDS!

*AVAILABLE ONLY IN CANADA



US and Canadian Patents Pending



Alarm sounds when door is opened.



Large clear window allows for unobstructed view of product.



Suggested product ideas for this system include:



Features & Benefits

- System allows access to one product at a time
- Flip door easily unlocks for convenient re-stocking
- Unit mounts and locks directly into uprights or can be mounted to a shelf
- Security alarm is activated when door is opened
- Easy lift handle for dispensing product
- Spring-loaded pushers keep merchandise up front and visible at all times
- Area for graphic or advertising insert
- Unlocks and slides out for easy reloading

Secure Merchandiser Shelf

Secure Merchandiser shelf is available in 24", 36", 48" widths and 12", 14", 16" and 18" depths.

- | | |
|----------------------|------------------------------------|
| 11 – Pushers | 11 – Easy Lift Handles |
| 10 – Dividers | 10 – Panel Sliders |
| 2 – Basic Snap Rails | 1 - Slider Shelf with Metal Topper |
| 1 – Alarm | |

48"W X 16"D

SECSYS001G2

*Please specify width and depth when placing order.

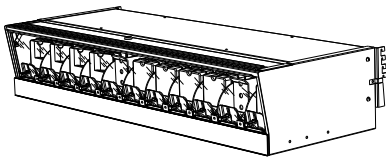

In-store setup using Invisi-Shield™ Panels and Marketing Impact Limited Dividers.



Crystal clear panels allow for unobstructed view of products at all times.



Optional locking panel with key for additional security.

INVISI-SHIELD™

INNOVATIVE LOSS PREVENTION SOLUTIONS TAILORED TO MEET YOUR NEEDS!

Great product visibility combined with the efficiency of a theft deterrent. The Invisi-Shield™ System represents a revolutionary approach in Loss Prevention Merchandising™ solutions. The Invisi-Shield™ System is available in styles to protect product merchandised on perforated shelving, peg hooks and pusher systems.



Invisi-Shield™ security setup with MIL medium duty pushers.



Invisi-Shield™ security setup with peg hooks.



Invisi-Shield™ security setup with MIL gum pusher system.

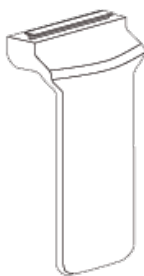

Invisi-Shield™ Panel Kit

High-impact clear plastic features a clicker mechanism to alert store associates of potential theft. Choose the panel size that best fits the width of your product.

4"W x 3-1/2"H (11 pcs. / bag)	PANEL001
3"W x 5-1/2"H (15 pcs. / bag)	PANEL002
4"W x 5-1/2"H (11 pcs. / bag)	PANEL003
4"W x 8"H (11 pcs. / bag)	PANEL004

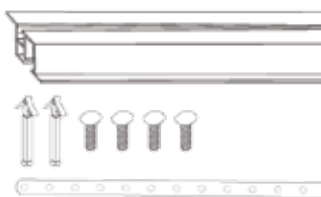

Invisi-Shield™ Hardware Kit

Kit Includes:

- 4 - Screws
- 2 - Installation Pins
- 1 - 48" Ratcheting Slide Bar

PANELKIT48

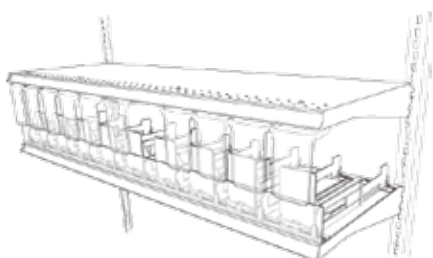

Invisi-Shield™ Standard Kit with Pushers 16" Deep

High-impact clear plastic Invisi-Shield panels are available in 4 sizes. Please specify desired panel size when placing your order:

4"W x 3-1/2"H 3"W x 5-1/2"H 4"W x 5-1/2"H 4"W x 8"H

Kit Includes:

- 1 - Invisi-Shield™ Hardware Kit
- 1 - Invisi-Shield™ Panel Kit
- 1 - 3" Front Fence
- 1 - Basic Snap Rail
- 10 - Dividers
- 9 - Pushers with Springs

Invisi-Shield™ Standard Kit with Pushers

INVISIKIT001

FORT KNOX™ SECURITY



Fort Knox™ Security Box with Active Alarm

Must use detacher to open box.

6 1/4"W x 9 15/16"H x 4 1/2"D	FSECA001
7 15/16"W x 9 3/4"H x 5 15/16"D	FSECA002
Detacher Micro DLS	DET1001



Fort Knox™ Security Box

Must use detacher to open box.

2 1/2"W x 8"H x 2"D	FSEC001
4"W x 6 5/8"H x 1 5/6"D	FSEC002
5 1/16"W x 7 1/8"H x 1 5/16"D	FSEC005
Detacher Micro DLS	DET1001



Fort Knox™ Security Hang Tab

Optional hang tab compatible with Fort Knox™ Security Boxes. Clips into security box for secure hold. Fits most standard plastic and metal hooks.

SECHAN001



HANGING RETAILERS



HANGING RETAILERS DISPLAY COMPONENTS

The most comprehensive and versatile hanging systems in the industry.

 **marketingIMPACT**
LIMITED

displaypeople.com

THE MAX HANGING MERCHANDISING SYSTEM

CROSS-MERCHANDISE ANY PRODUCT, MAXIMIZE ANY SPACE, ADD SIGNAGE AND WATCH SALES SOAR!

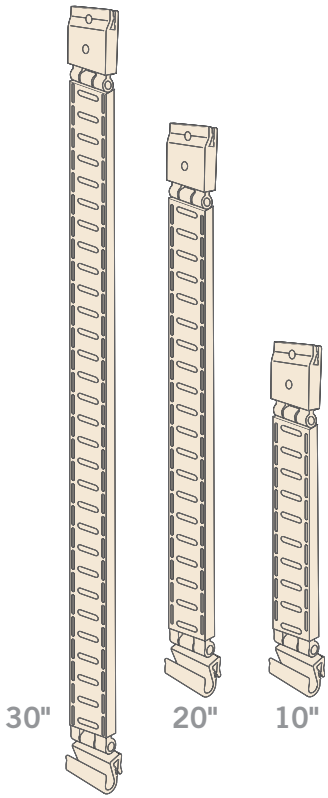

30" 20" 10"

The Max

Meet the MAX — your solution for turning empty space into a profit centre!

Utilizes many different hooks to hold an amazing variety of products, as well as graphics and price cards. Mounts to any shelving system or fixture. Moulded in virtually unbreakable high-impact styrene.

Each MAX is 10", 20" or 30" in length and include hangers on both ends. One end can mount to a shelf and the other to a wire.

Use Marketing Impact Limited's Adhesive Hang-Tabs to place virtually any product on a hook.

30" Length (white)	MAXWHITE30
20" Length (white)	MAXWHITE20
10" Length (white)	MAXWHITE10

*Custom colours available. Minimum quantities apply.



HOW DOES IT WORK?

The MAX : Mounting and Applications

The MAX can be suspended numerous ways and can easily be linked to another MAX for extended merchandising power. It holds a variety of standard hooks, which you can position based on the size of your product.

LOOK HOW MANY DIFFERENT WAYS YOU CAN HANG THE MAX:

- A** From a shelf bracket
- B** Using our MAX Hanger
- C** From a wire bin or sidewinder
- D** With Self-Centering Mount
- E** Adding Signholder Frames
- F** With the MAX Cardholder
- G** Linked to another MAX!
- H** From expandable brackets

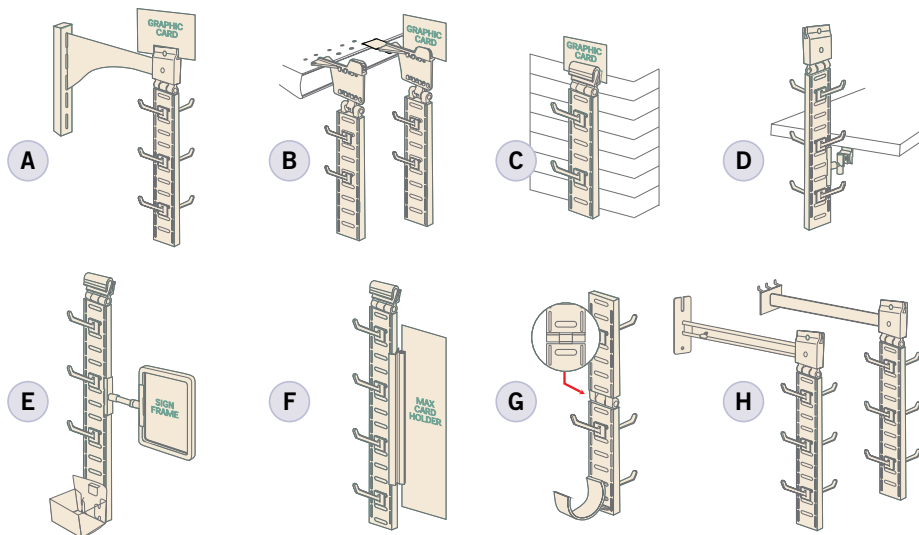

NEW

Gift Card Extender

Double sided graphics can be displayed using our integrated card clips. Use the Gift Card Extender with The MAX, or use the optional Double Clip to hang 2 strip retailers and add a topper graphic. (see page 118)

Clear	GIFTEXTCL
White	GIFTEXTWH
Black	GIFTEXBK

*Custom colours available. Minimum quantities apply.

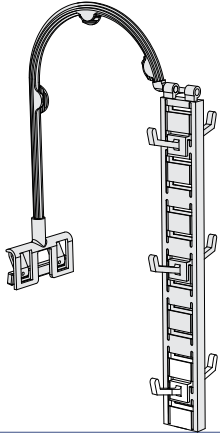

HOW DOES IT WORK?

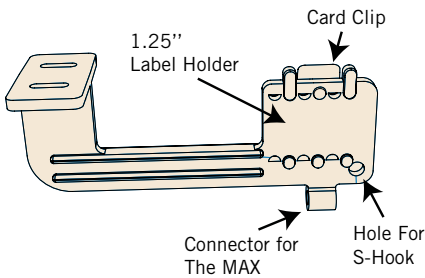
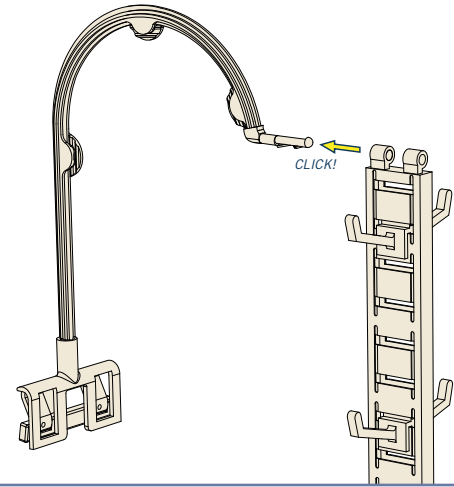

The Extended MAX Hanger

Can be moulded in coloured high-impact styrene or clear polycarbonate. Attaches under a shelf with screws. Connects the MAX to a perforated shelf. Sports a signholder on the top for graphics or price card.

Clear	EXTMAXCL
Beige	EXTMAXBG
White	EXTMAXWH
Black	EXTMAXBK

*Custom colours available. Minimum quantities apply.

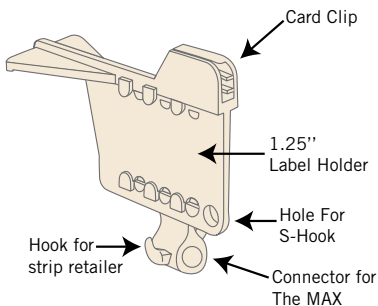

The MAX Hanger

Moulded in polycarbonate, the MAX Hanger connects the MAX to a perforated shelf. Sports a signholder on the top for graphics or price card.

Beige	MAXHANGERBG
Black	MAXHANGERBK
Clear	MAXHANGERCLR

*Custom colours available. Minimum quantities apply.

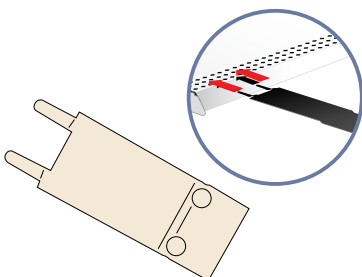

The MAX Extension Bracket

Extend the MAX further into the aisle for maximum exposure.

2" L	MAXBRACKET2
4" L	MAXBRACKET4
6" L	MAXBRACKET6

*Available in black. Custom colours available. Minimum quantities apply. Available in white

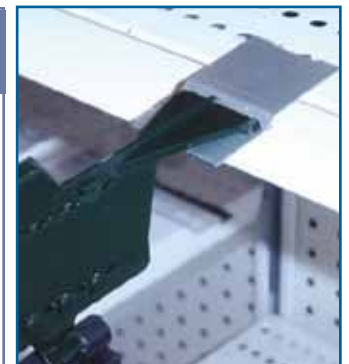

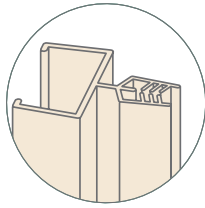

The MAX Card Holder - Clear

One side snaps onto The MAX edge, the other side has a gripper to hold graphics.

3"L

MAXCARDHOLDER

*Custom colours available. Minimum quantities apply.

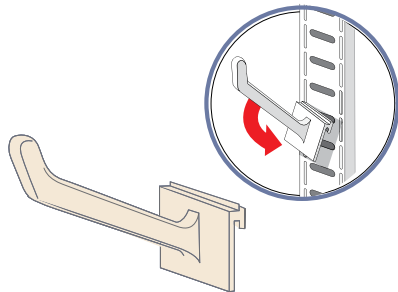

The MAX Hook

Designed specially for use with The MAX.

3/4"L

MAXHOOK3/4

2"L

MAXHOOK2

3"L

MAXHOOK3

4"L

MAXHOOK4

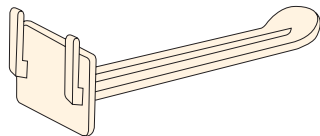

The MAX Butterfly Hook

This hook holds packages with butterfly and delta holes.

4"L

MAXBHOOK04

5"L

MAXBHOOK05

6"L

MAXBHOOK06

*Available in white.

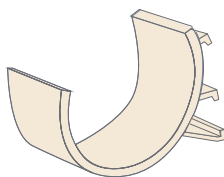

The MAX Bottle Holder - Clear

A special hook designed for holding bottles with the MAX.

clear

MAXACC001

*Custom sizes available. Minimum quantities apply.

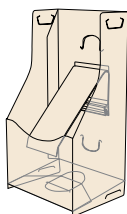

The MAX Pocket with Versa Pusher Clip

Hooks onto The MAX and pushes product forward. Manufactured in clear PVC.

4"W x 7-1/2"H x 3"D

MAXPV001

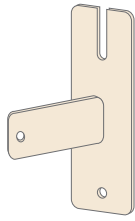

The MAX Bracket for Warehouse Uprights

Mounts to standard uprights. Tightens with a screw and wing nut.

MAXWHBRACKET

*Available in black, clear, red and white. Please specify colour when placing order.

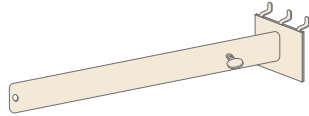

The MAX Pegboard / Slatwall Bracket

Mounts to standard uprights, extending 16" and putting The MAX beyond the shelf and product. Tightens with a screw and wing nut.

MAXSHELBRACKET

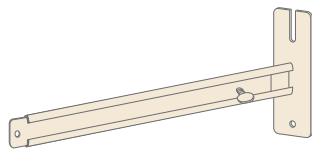

The MAX Universal Bracket

Mounts to standard uprights, extending The MAX beyond the shelf and product. Extends 12" - 23" in length. Tightens with a screw and wing nut.

MAXSLBRACKET



The MAX Spinner Bracket

To be used with 3-Way Spinner and mounts to a perforated shelf.

15-1/2"H

MAXSPNBKTVH15

*Custom lengths available.

Please specify desired length when placing order.



NEW

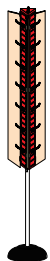

Shown with Pedestal Stand

The MAX FloorSpinner

The 3-Way MAX Spinner increases the product you can display by 3 times and will accommodate 3 graphic panels to boost impact and sales. The MAX Spinner is designed to mount to various bases and extension arms placing your product in a wide range of areas.

PMAXSPIN

NEW



The MAX Counter Spinner

The 3-Way MAX Spinner increases the product you can display by 3 times. The MAX Spinner is designed to mount to various bases and extension arms placing your product in a wide range of areas.

MAXSPINNER

STRIP RETAILERS AND ACCESSORIES

NEW

Double Sided Hanging Retailer Extender

HOW DOES IT WORK?

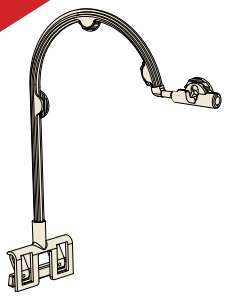

Fits most wire and flat fences. Moulded in polycarbonate. Available in Clear, White and Black.

Clear	GIFTEXTCL
White	GIFTEXTWH
Black	GIFTEXTBK

**Custom colours available. Minimum quantities apply.*

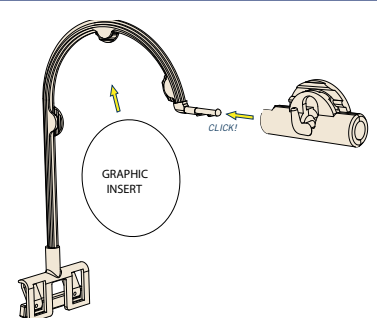

HOW DOES IT WORK?

HEAVY DUTY MOULDED STRIP RETAILERS

Includes interchangeable graphic card holder Moulded in durable Polyethylene.

Strips snaps together to be used as double sided - 24 clips



Snap at end of strip allows you to extend length of strip

NEW

Heavy Duty Moulded Strip Retailers



12 Hooks with Label Area. Products clip onto strips. Can become a double sided strip retailer. Label area 2-3/8" W X 1-1/2"H

28-7/8" L - Black	SCR00325B
28-7/8" L - White	SCR00325W
28-7/8" L - Natural	SCR00325N



Light Duty Strip Retailer (12 Clip)

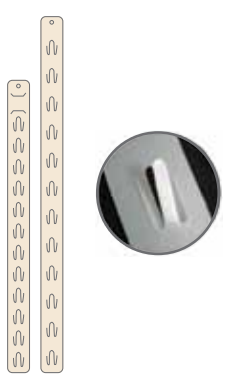

Products attach with ease. Made in HDPE

22" L	SCR00422L
28" L	SCR00428L

**Available in Natural.*



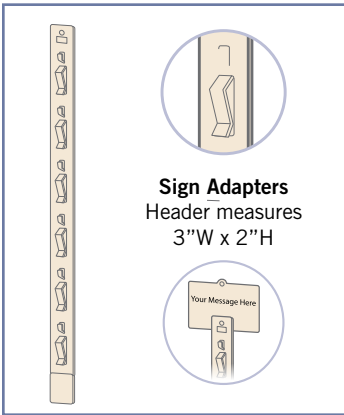

Standard Strip Retailer

Products can be hooked or clipped on. Available in 6 or 12 clips with or without adhesive.

(6) ¾"W x 16½"L	SCR00516
(12) ¾"W x 32½"L	SCR00712
Graphic measures 2¾"W x 1¼"H	SCR007DHR

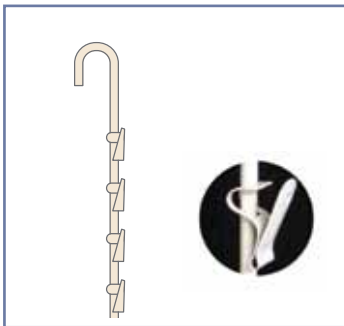

Hanging Wand Retailer

Designed for heavier merchandise. Steel with beige or grey enamel finish. Please specify when ordering.

No Header / Grey (12 Clips)	SCR00612GY
-------------------------------	------------



SCR00612GY
Hanging Wand Retailer

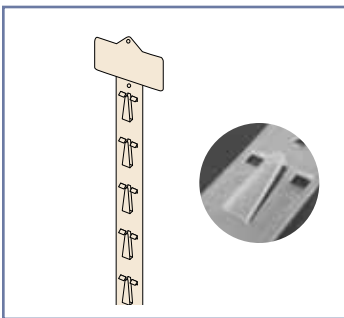

Locking Strip Retailer (with Header)

Injection moulded for durability. Loads easily and locks for secure shipment. Header measures 3"W x 1-3/8"H. 12 Hooks. Strip measures 1-1/8"W.

(24½") with Header - Hooks 2" apart	SCR00624H
(30") with Header - Hooks 2½" apart	SCR00630H

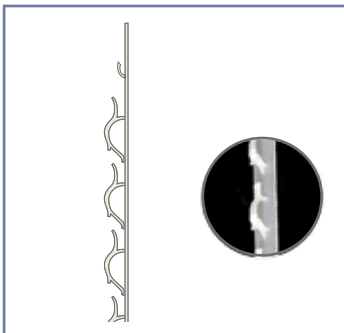

Single-Sided Strip Retailer

Consists of 6 closing hooks. Each strip is designed to lock into another strip forming continuous lengths. Available with or without self adhesive tape.

¾"W x 6-1/2"L w/ Adhesive	SCR00506A
¾"W x 6-1/2"L w/o Adhesive	SCR00506

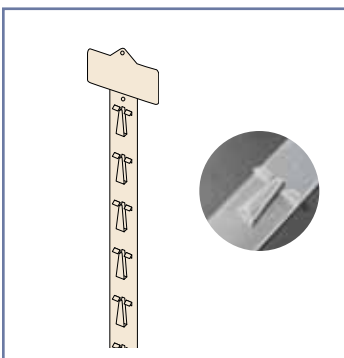

Double-Sided Strip Retailer (with Optional Header)

Injected moulded for durability. Loads easily and locks for secure shipment. Header measures 3-1/2"W x 1-3/8"H. 12 Hooks. Strip measures 1-1/8"W. Available in 24-1/4" and 30" lengths.

24-1/4"L with Header (Hooks 2" apart)	SCR00625H
22-1/4"L No Header (Hooks 1-7/8" apart)	SCR00624

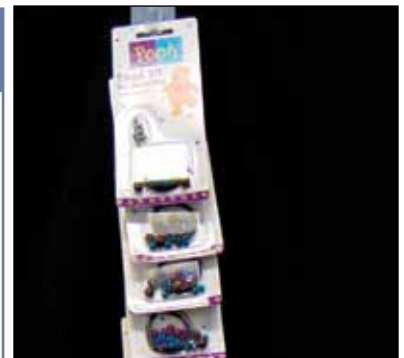

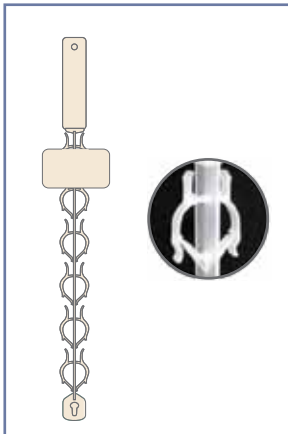

Double-Sided Strip Retailer (12 Clip)

Closing hooks for back-to-back display.
Header measures 2-1/8"W x 1-1/4"H. Strip measures 14"L.

2-1/8"W x 1¼"H

SCR00800

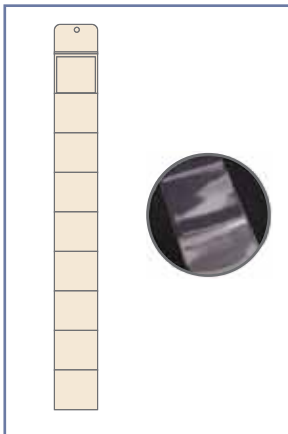

Durable Vinyl Pouch Strip Retailer

Pockets are custom made to fit your product. Perfect for boxes, bottles, tubes and more. Top pocket for graphics or price card.

Up to 30" Long

SCR10008

Custom Sizes Available.

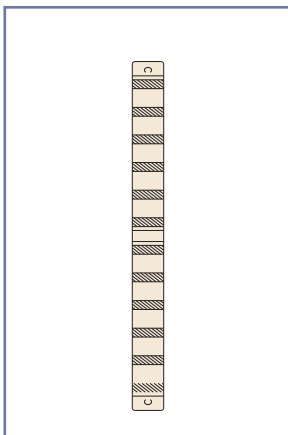

Adhesive Display Strip

12 square adhesive display retailer for light weight packages.

1-3/8"W x 19-3/4"L

SCR0012

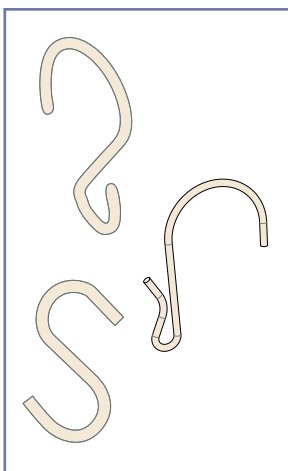

Strip Retailer Mounting Hooks

Attach a Strip Retailer almost anywhere to merchandise products. 0.080" diameter nickel plated wire.

S-Hook Loop (Open Style)

ACC002

S-Hook Loop (Crimped Style)

ACC002P

S-Hook

ACC004

DISPLAY COMPONENTS



Display Pole - Corrugate

Two-piece, 6' long pole, available in three diameters. Inner core holds pole pieces securely together. White litho (paper). Additional sizes and colours available, Pole requires wire feet to work.

1" OD — 13/16" ID	SHA240A
1-1/2" OD — 1-1/4" ID	SHA240B
1-3/4" OD — 1-15/32" ID	SHA240C

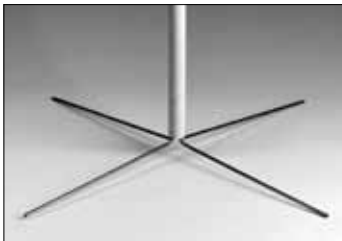

Wire Feet

Two-piece, set of overlapping wires slip inside display pole base to create a sturdy foot. Available in three sizes for different diameter poles. Use with Display Poles. 24" span. Made from wire.

24" Diameter — 13/16" ID	SHB160A
24" Diameter — 1-1/4" ID	SHB160B
24" Diameter — 1-15/32" ID	SHB160C

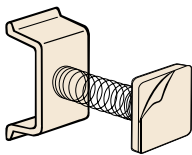

Channel Mount Spring Wobbler

Fits most 1-1/4" shelf channels. Permanent adhesive holds signs and promotional items. White polypropylene / styrene with 1"L metal spring.

SHC140

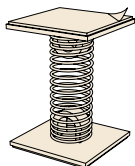

Spring Wobbler

1"L metal spring with adhesive mounting ends. Adheres to any flat surface. Holds signs and promotional items. White styrene with metal spring.

SHC150

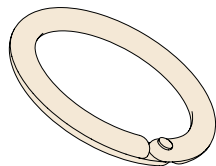

Split Ring

Easy-to-close, one-piece design. 5/8" ID. White split ring is manufactured in polyethylene. Clear split ring manufactured in plastic.

Clear	ACC270C
White	ACC270W

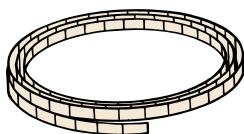

Flexible Magnets

Scored magnetic roll that is 1/2"W x 1"L with 1200 magnets per roll. Clear permanent adhesive on back.

Roll of 1200	ACC510
--------------	--------

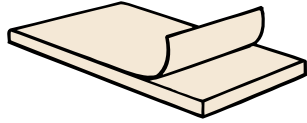

Adhesive Piece Roll

Double-sided, foam adhesive pads, 3/4"W x 2-3/4"L x 1/16" thick.

Roll of 5000

ACC520

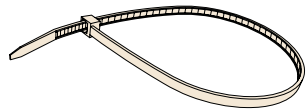

Permanent Locking Straps

Notched full length. 1/8"W. Natural nylon.

4"L

ACC6004

8"L

ACC6008

11"L

ACC6011

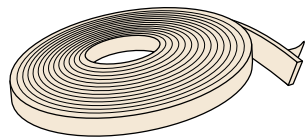

Adhesive Roll

Double-sided foam adhesive roll, 1/2"W x 1/32" thick.

1 Roll (216')

ACC521

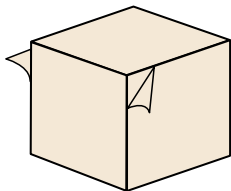

Foam Block Stand-Off

Double sided foam tape block attaches with permanent adhesive.

1"H x 1"W x 1"D

ACC401

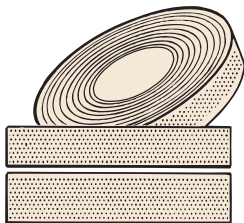

Hook & Loop Fastener Roll

Adhesive backed continuous roll. Each roll measures 25 yards X 5/8"W.

Hook Fastener

VELO02WHH

Loop Fastener

VELO02WHL

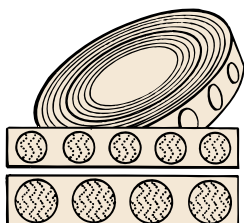

Hook & Loop Fastener Button Roll

Adhesive backed buttons. 3/4" diameter. Each roll contains 1028 buttons.

Hook Fastener

VELO03WHH

Loop Fastener

VELO03WHL

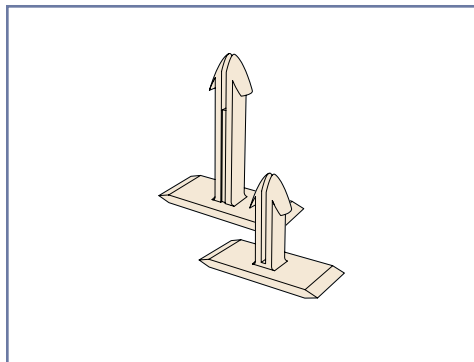

Arrow Fastener

Securely holds pads of coupons or single signs in the centred flush position. Stem 1/2" L. Manufactured in natural polypropylene.

Arrow Fastener with Adhesive ACC110A

Arrow Fastener with No Adhesive ACC110NA

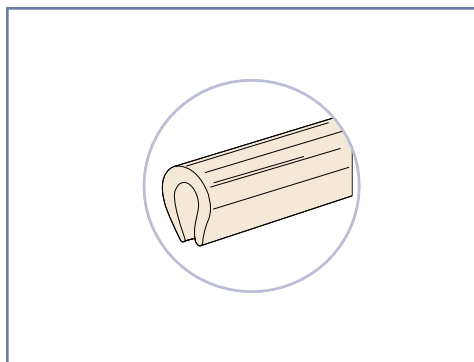

Clear Edge Protector

Covers unfinished corrugated / plastic display edging. Manufactured in flexible PVC.

Clear SHE131

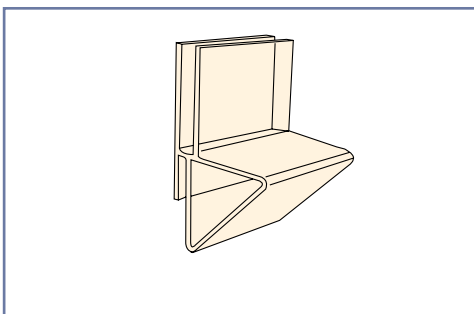

Shelf Support — Single

Single capacity holds thickness of 1/8" corrugated shelf construction and 1/8" display wall.

Shelf Support — Single SHC047-CC

Shelf Support — Single (with Adhesive) SHC047-CC3

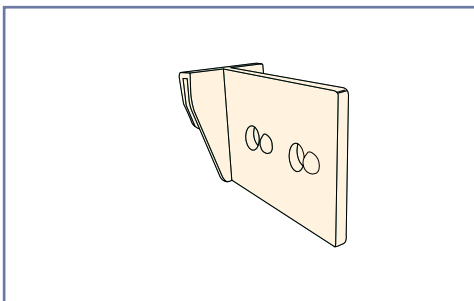

Shelf Support — Vertical

Fits up to 1/8" corrugate. Measures 2" in length.

Natural Polypropylene SCH048

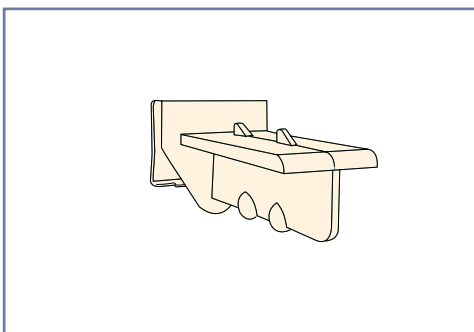

Shelf Support — Horizontal

Fits up to 1/8" corrugate. Measures 2" in length with teeth along sides and top for maximum grip.

Natural Polypropylene SCH048-HD

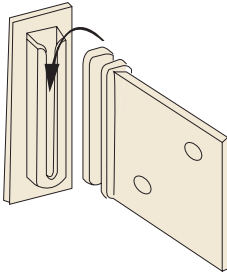

Shelf Support — 2 Piece

Allows for pre-attachment to corrugated displays. Fits up to 3/16" corrugate. Shelf Support — 2 Piece. Manufactured in white polypropylene.

1-7/8"H x 2-1/4"L

SHC049

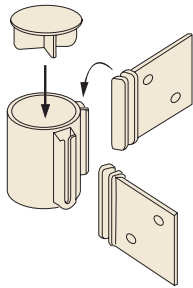

Shelf Support — 4 Sided

Allows signs to display four ways with cap to provide finished look. Fits 1-3/4" OD display poles. Holds up to 3/16" corrugate. Manufactured in white polypropylene.

2-1/2"H

SHC055

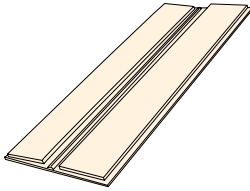

Flexible Hinge

Extruded hinge with two 1/2" wide adhesive strips adhere to most flat surfaces. Manufactured in Clear PVC.

1-1/4"W x 3"L

SHE0009CLEAR

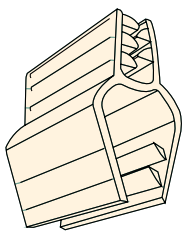

SuperGrip® 2-Way Clip

2-way clip holds material up to .080" thick in one side, and 1/8" - 3/16" thick in the other side. Manufactured in Clear PVC.

1"W x 1"H

SHC038CLEAR01

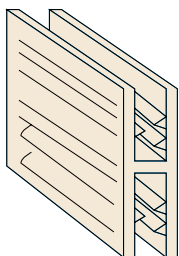

SuperGrip® H-Clip

Connect panels / signs horizontally and vertically. Attach signs above displays or fixtures. Holds up to .080 thick material. Manufactured in Clear PVC.

3"L

SHC600

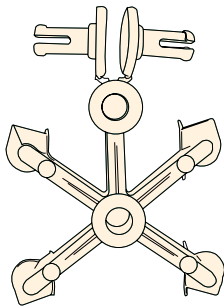

Spider Clip

Mounts to standard 1-1/4" shelf channel to display literature boxes. Mounts using two dart clips. Manufactured in Natural Polypropylene.

ACC900

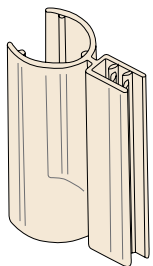

SuperGrip® Signholder Pole Gripper

Clips onto 1"OD pole or tube. Holds material up to 3/16" thick. Manufactured in Clear PVC.

3"

SHC400

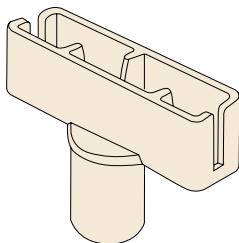

Display Pole Signholder

Holds sign securely at the top of display poles (SHA240A, SHA240B, SHA240C). Fits 1" OD or 1-7/16" ID. Holds material .018" - .060" thick styrene. (see page 121)

Fits 1" ID or 1-7/16" OD

SHC410

Fits 13/16" ID

SHC411

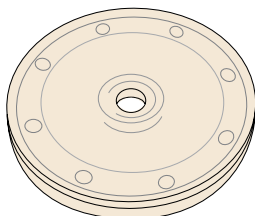

Plastic Turntable

Can be attached to displays and fixtures to provide a sturdy base. Manufactured in clear styrene.

5-1/2"

TUR001

12"

TUR005



DISFOOT

Display Foot protects display bases while permitting corners to flex.



DISCASTER

Display Casters protect and assist when moving displays.

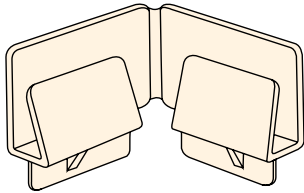

Display Foot

Lifts display 1/2" off the floor. Holds up to 5/16" corrugate. Manufactured in polypropylene.

DISFOOT

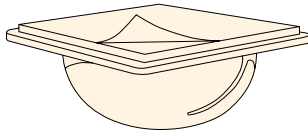

Display Caster

Lifts displays 3/4" off the floor making the display easier to move when needed. Casters adhere to the bottom of the display. Manufactured in natural polypropylene.

DISCASTER

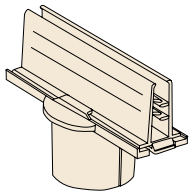

SuperGrip® Signholder for Display Poles

Add signage to display poles (SHA240A, SHA240B, SHA240C). Fits 1" OD and 1/4" ID. Holds material up to 3/16" thick. White styrene base with clear PVC sign holder. (see page 121)

3"L

SHC405

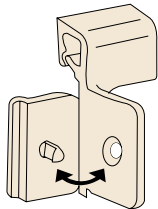

Clip-In Data Strip Fold N Hold

Clips onto your sign so that it can be displayed from a data strip. Holds paper signs up to .012" thick. Manufactured in natural polypropylene.

SIGN205

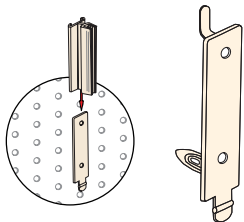

Signholder Pegboard Bracket

Fits most standard pegboard 3/4"W x 2-5/8"H mounting area. To be used with signholders or adapters.

White

PEG010



SIGN205
Clip-In Data Strip
Fold 'N' Hold

HOOKS, HANGERS & LABEL HOLDERS

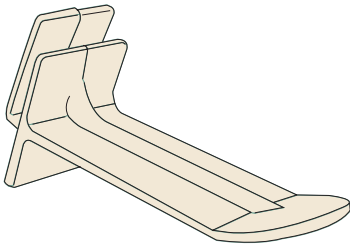

Corrugate Display Butterfly Hook

Holds packages with butterfly and delta holes. Fits 1/8" corrugate.

2" L	HK0137-2
4" L	HK0137-4
6" L	HK0137-6

*Available in white or black. Please specify colour when ordering.

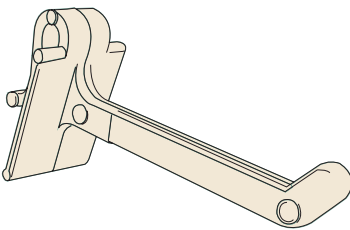

Wire and Corrugate Display Hook

Holds packages with a variety of hole styles. Fits 1/8" - 3/16" corrugate. Fits .148" - .177" diameter wire.

2" L	HK0138-2WH
3" L	HK0138-3WH
4" L	HK0138-4WH
6" L	HK0138-6WH
8" L	HK0138-8WH

*Available in white.

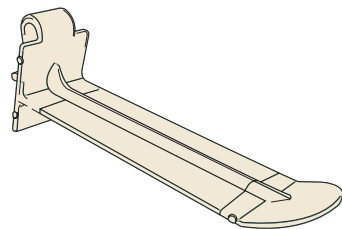

Wire and Corrugate Display Butterfly Hook

Holds packages with butterfly and delta hole. Fits 1/8" - 3/16" corrugate. Fits .148" - .177" diameter wire.

3" L	HK0139-3WH
4" L	HK0139-4WH
5" L	HK0139-5WH
6" L	HK0139-6WH
7" L	HK0139-7WH
8" L	HK0139-8WH

*Available in white.

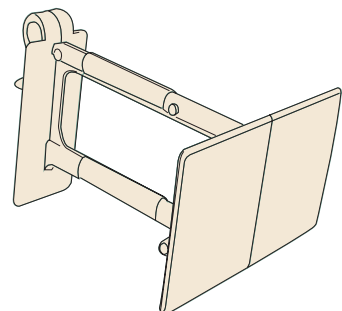

Wire and Corrugate Display Hook with Scan/Label Plate

Holds packages with a variety of hole styles. Scan plate measures 2-1/8"W x 1-3/8"H. Fits 1/8" - 3/16" corrugate. Fits .148"-.177" diameter wire.

2" L	HK0140-2WH
3" L	HK0140-3WH
4" L	HK0140-4WH
6" L	HK0140-6WH

*Available in white.

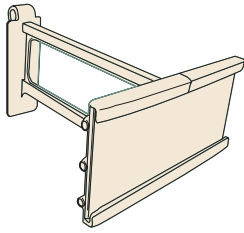

Wire and Corrugate Display Hook with C-Channel

Holds packages with a variety of hole styles. C-channel size measures 1-1/4"H x 3"W. Fits 1/8" - 3/16" corrugate. Fits .148" - .177" diameter wire.

3" Length	HK0141-3WH
4" Length	HK0141-4WH

*Available in white.

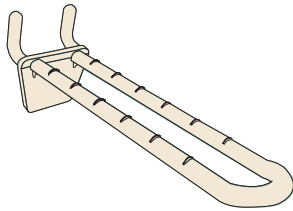

Double Duty Loop Hook

Holds packages with butterfly and delta holes. Ribbed hook keeps merchandise from sliding. Fits 1/4" pegboard holes and most slatwall.

4" Length	HK0143-4WH
6" Length	HK0143-6WH
8" Length	HK0143-8WH

*Available in white.

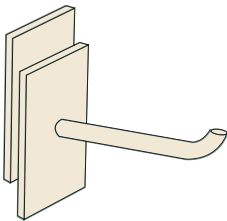

Display Hook

Use with a variety of package hole styles. Fits 1/8" corrugate.

2" Length	HK0142WHT
4" Length	HK0144WHT
5" Length	HK0145WHT
6" Length	HK0146WHT
7" Length	HK0147WHT
8" Length	HK0148WHT

*Available in white.

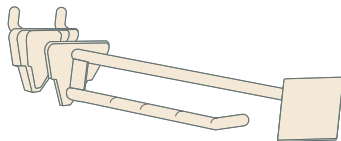

Two-Piece Scanner Hook

2" Length	HK0322
4" Length	HK0324
6" Length	HK0326
8" Length	HK0328

*Available in white and black. Please specify colour when placing order.

*Custom colours available. Minimum quantities apply.

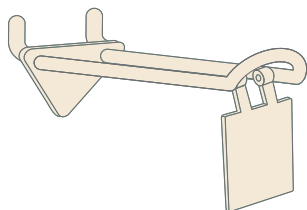

Double Round Hook with Tab

Tab measures 1" x 1-3/8"

2" Length	HK0232
4" Length	HK0234
6" Length	HK0236
8" Length	HK0238

*Available in white and black. Please specify colour when placing order.

*Custom colours available. Minimum quantities apply.

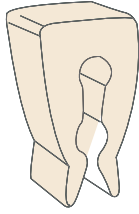

Inventory Control Clip

Moulded from soft plastic. Used to keep products towards the front of the hook.

R23-135

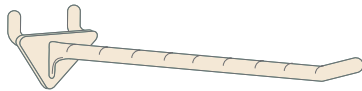

Ribbed Round Hook

1" Length	HK0121
2" Length	HK0122
4" Length	HK0124
6" Length	HK0126
8" Length	HK0128

*Available in white and black. Please specify colour when placing order.
 **Custom colours available. Minimum quantities apply.

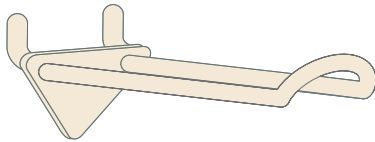

Double Round Hook

15/16"W x 2"L	HK0222
15/16"W x 4"L	HK0224
15/16"W x 6"L	HK0226
15/16"W x 8"L	HK0228

*Available in white and black. Please specify colour when placing order.
 **Custom colours available. Minimum quantities apply.

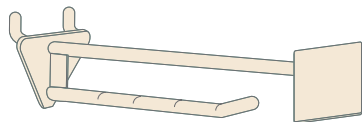

Scanner Hook

2" Length	HK0312
4" Length	HK0314
6" Length	HK0316
8" Length	HK0318

*Available in white and black. Please specify colour when placing order.
 **Custom colours available. Minimum quantities apply.

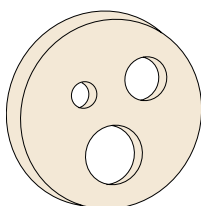

Black Product Stop

Use as an inventory control unit or product stopper. Three holes fit a variety of standard hooks. 15/16" diameter. Manufactured in black rubber.

Bag of 250 ACC500

HANG TABS

	<h3>Fold-Up Hang Tab</h3> <p>2-1/2"W x 1-1/2"H with delta hole.</p> <p>4500 Per Roll HK100</p>
	<h3>Flexible Hang Tab</h3> <p>1"W x 2"L with 7/16" diameter hole.</p> <p>10 Per Pad HK101</p>
	<h3>Large Easy Peel Hang Tab</h3> <p>2"W x 1-1/2"H</p> <p style="text-align: right;">HK061</p>
	<h3>Basic Easy-Peel Hang Tab</h3> <p>1-5/8"W x 1-3/8"H</p> <p style="text-align: right;">HK062</p>
	<h3>Easy-Peel Hang Tab</h3> <p>1"W x 3/4"H</p> <p style="text-align: right;">HK063</p>
	<h3>Flexible Hang Tab - Wide</h3> <p>2"W x 1-7/8"H with delta hole.</p> <p>10 Per Pad HK103</p>
	<h3>Hook Hang Tab</h3> <p>7/8"W x 1-3/8"H</p> <p style="text-align: right;">HK102</p>

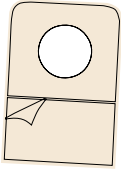

Hang Tab Sheet

7/8"W x 1-1/2"H with 7/16" diameter hole.

36 Per Sheet HK064

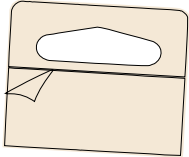

Hang Tab Sheet - Wide

1-1/2"W x 1-1/16"H

20 Per Sheet HK066

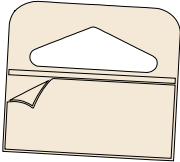

Hang Tab

1-5/8"W x 1-3/4"H

Sold Individually HK068



Hang Tab - Cylinder

1lbs - 5lbs. recommended weight.

6"L x 3/8"W HS0010



Large Handle Strap

30 lbs. recommended weight support.

23"L x 1-3/8"W HS0020



Small Handle Strap

15 lbs. recommended weight support.

17"L x 1"W HS0015



Easy Carry Handle

5 lbs. recommended weight support.

3-1/8"H x 5-1/2"W HS0005

CEILING HANGERS



Rotating Ceiling Hook

Locks onto 1" drop ceiling grid and is designed for easy attachment and removal. Rotates into place. Manufactured in polycarbonate.

Clear

ACC170



Ceiling Grip Clip

Semi-permanent connector snaps onto standard 1" drop ceiling grid. The 1/8" diameter hole is for use with barbed cords. Manufactured in butyrate.

Clear

ACC175



Ceiling Twist Clip

Snap hinge locks securely to standard 1" drop ceiling grid. Twist off easy removal. Extends 1-1/2" from ceiling. Manufactured in polypropylene.

White

ACC176



Ceiling Loop

Permanent adhesive base sticks to standard drop ceiling grid. The 3/16" loop opening is great for barbed cords, double c-hooks and jet wire. Manufactured in styrene.

White

ACC180

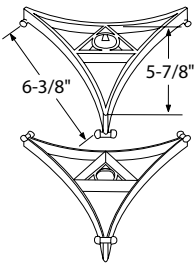

Mini Triarama Mobile Kit

Three-sided mobile gives you maximum exposure from ceiling, shelf or floor. Plastic formers support 3 panels from 10" to 24" wide. Kit includes a top and bottom former, twist-on mini, hook and cord.

ACC190

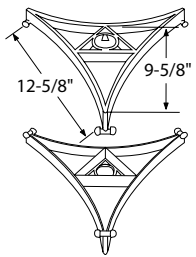

Triarama Mobile Kit

Three-sided mobile gives you maximum exposure from ceiling, shelf or floor. Plastic formers support 3 panels from 15" to 40" wide. Kit includes a top and bottom former, twist-on mini, hook and cord.

ACC191



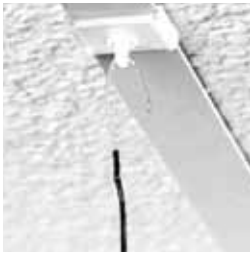

Mobile Spring

Hangs displays at exactly the height you want. Manufactured in steel wire.

6" (Stretches to 4')	HK22206
8" (Stretches to 5')	HK22208
12" (Stretches to 8')	HK22212

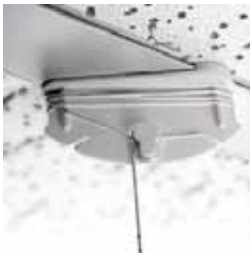

Twist-On Mini Clip

All-in-one solution for hanging light signs and banners from a 1" drop ceiling grid. Comes with white cotton or monofilament cord.

White	ACC240
-------	--------



Twist-On Clip

For use on standard 1" drop ceiling grid. Simply align connector to drop ceiling grid and twist on. Works with s-hooks, chains, jet wire and cable connectors. Manufactured in medium impact polystyrene.

	ACC241
--	--------



Metal Grid Clip

Squeezes onto standard 1" drop ceiling grid. Excellent connector to hang lightweight mobiles, signs, banners and decorations. Manufactured in galvanized spring steel.

	ACC250
--	--------

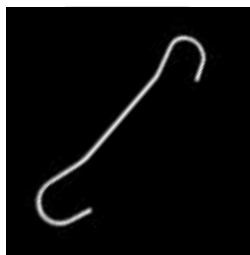

Double C-Hook

Nickel plated wire.

6"L	DCH06
12"L	DCH12
24"L	DCH24
36" L	DCH36

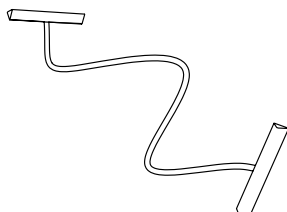

Elastic Cord with Barbs

Elastic cords that stretch approximately twice their length. Black polyester with silver barbs.

Cord lengths range from 1" - 18"	ACC801 - ACC818
----------------------------------	-----------------

*Please specify cord length when placing order.

SUCTION CUPS

SUCTION CUP APPROXIMATE HOLD WEIGHT:

Small 1 1/8" diameter suction cup holds 1lb.

Medium 1 3/4" diameter suction cup holds 3lbs.

Large 2 1/2" diameter suction cup holds 7lbs.



Suction Cup with Mushroom Head

Simplified design accommodates a wide range of self-hanging products.

Small (1-1/4" Diameter)	ACC100
Medium (1-3/4" Diameter)	ACC101
Large (2-1/2" Diameter)	ACC102



Suction Cup with Metal U-Hook

Deep hook design is ideal for window mounted signs, ornaments or decorations.

Small (1-1/4" Diameter)	ACC120
Medium (1-3/4" Diameter)	ACC121
Large (2-1/2" Diameter)	ACC122



Suction Cup with # 8-32 Stud and Nut

The preferred hanger for screw mountable signs, thermometers, etc. Brass knurled nut.

Small (1-1/4" Diameter)	ACC130
Medium (1-7/8" Diameter)	ACC131
Large (2-1/2" Diameter)	ACC132



Suction Cup with Check Hook

Hanging system for multiple or changing loads. Light diffusing cup and the hook is made of corrosion-rust proof metal.

1-3/4" Diameter	ACC140
-----------------	--------



Suction Cup with Plated Metal Clamp

Holds signs, notes and advertising on windows, refrigerators and other slick surfaces.

1-1/8" Diameter	ACC150
1-1/8" Diameter	ACC151

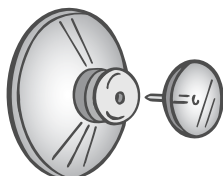

Suction Cup with Thumbtack

Holds signs, notes and advertising on windows, refrigerators and other slick surfaces.

1-3/4" Diameter	ACC700
-----------------	--------

FASTENERS

	<h3>Christmas Tree Push Pin</h3> <p>11/16" Diameter Head. Fits 1/4" Diameter Holes. Natural Nylon.</p> <p>3/16" - 1/2" Grip PPN001</p>
	<h3>Belly Button Push Pin</h3> <p>To securely attach dividers to shelves. 100 per bag, natural nylon.</p> <p>For 1/4" Diameter Holes PPN002</p>
	<h3>Universal Push Pin</h3> <p>.430" diameter head. Natural nylon. Fits 3/16" Diameter Holes.</p> <p>3/16" Grip UPP001</p>
	<h3>Arrowhead Thumbsnap</h3> <p>.2" Grip with 1/2" diameter head. Available in black and clear polypropylene. Fits 1/4" Diameter Holes.</p> <p>Black ACC111BK Clear ACC111CL</p>
	<h3>Universal Push Pin Remover</h3> <p>Ideal for removing fasteners from shelves.</p> <p style="text-align: right;">PPR001</p>
	<h3>Screw and Wing Nut Set</h3> <p>To securely attach dividers to shelves. 100 sets per bag.</p> <p>#10 - 24 x 3/4" PPN003</p>
	<h3>Viking Screws</h3> <p>.79"L with .500" head diameter, clear styrene. Fits 3/16" Diameter Hole.</p> <p style="text-align: right;">ACC040</p>

FLOOR STANDING MERCHANDISER

Capitalize on impulse sales with MIL's 360 degree Floor Standing Merchandiser. Fully customizable to suit your needs, our Floor Standing Merchandiser is comprised of modular pieces allowing you to outfit your display the way you want. Add up to 8 levels of our Multi-Purpose Bins, suspended from either a 3-Way Wire Carousel or 4-Way Wire Carousel. Top your display off with eye catching signage using our Sign Clip Adaptor, and/or a Clear Bowl for showcasing a product of the week!

1 Choose Your Pole and Base

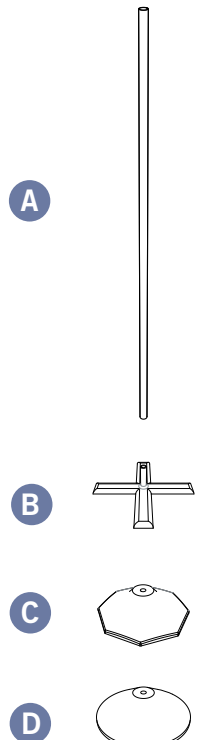

2 Choose Your Accessories

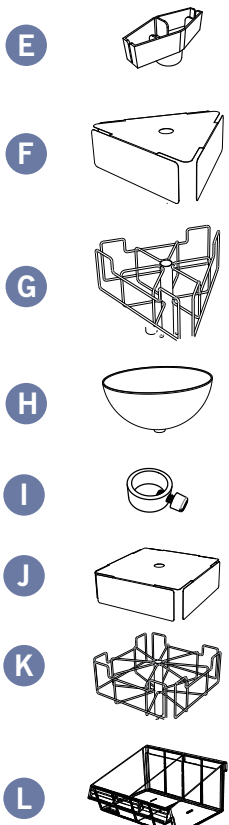

3 SETUP

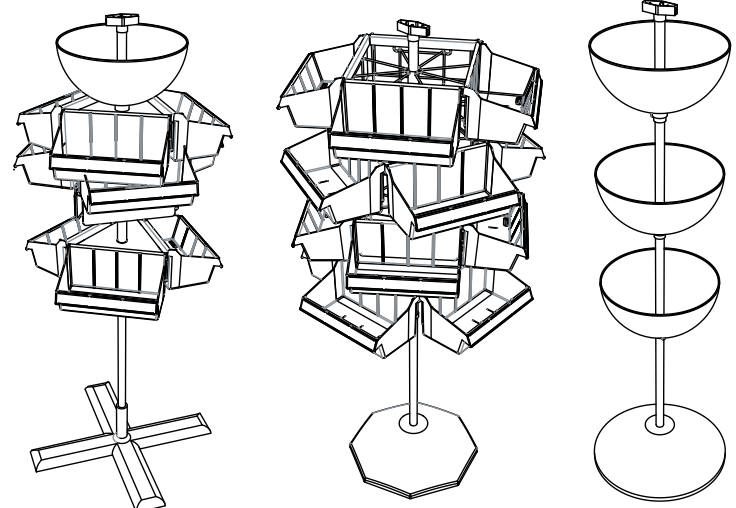

LEGEND

- | | | | |
|-------------------------|----------------------------|--------------------------------|---------------------------------------|
| A Display Pole | D Trumpet Base | G 3-Way Carousel | J 4-Way Baffle |
| B Cross Base | E Sign Clip Adaptor | H Clear Bowl with Stem | K 4-Way Carousel |
| C Octagonal Base | F 3-Way Baffle | I Plastic Support Clamp | L Multi-Purpose Adjustable Bin |

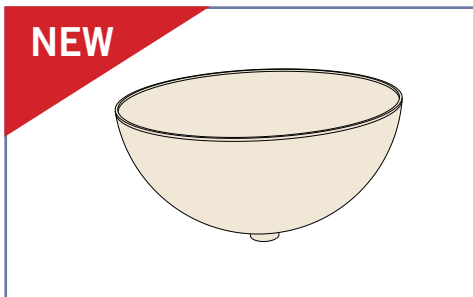

NEW

Clear Bowl with Stem

Capitalize on impulse sales. Add the Clear Bowl to the 1" diameter Display Pole to merchandise your products, and fasten in place with a Plastic Support Clamp.

14" Diameter X 6-3/4" H

MB0005

NEW

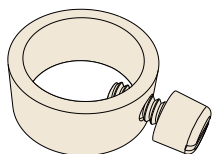

Plastic Support Clamp

Use in conjunction with the 1" diameter Display Pole SHA240A to support merchandising systems that need fastening.

1" Inside Diameter

SHC414

NEW

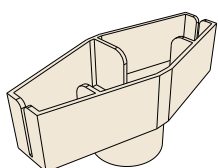

Sign Clip Adaptor

Securely display signage at the top of a 1" diameter Display Pole SHA240A. Holds material from 0.060" to 0.18" thick.

3-1/2" Long

SHC415

NEW

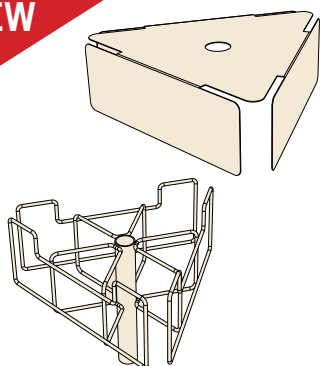

3-Way Wire Carousel

3-Way Wire Carousel WC3W

3-Way Baffle WB3W

*Custom colours available.
Minimum quantities apply.

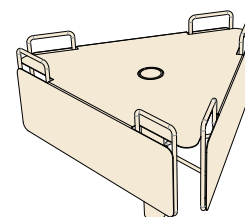

NEW

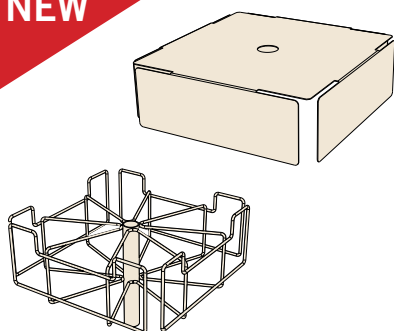

4-Way Wire Carousel

4-Way Wire Carousel WC4W

4-Way Baffle WB4W

*Custom colours available.
Minimum quantities apply.

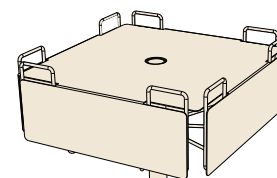

NEW

Display Pole - Metal

61" H

DP001

*Custom colours available. Minimum quantities apply.

NEW

1.

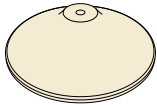

2.

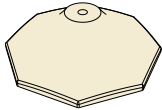

3.

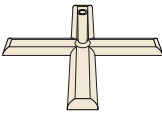

Bases

1. Trumpet Base

DB0002

2. Octagonal Base

DB0003

3. Cross Base

DB0004

NEW

Revolving Clip Strip Display

6 Clip Strips in one display, totalling 108 clips. Each clip strip is placed 4" apart from the other.

63"H X 9"D Base

RCSD001

*Available in black or red. Please specify colour when ordering.

NEW

Wire Dump Bin

Features an adjustable base that can take the Wire Dump Bin to 3 different depths in order to accommodate a wide variety of products.

30"H X 17"W X 18"D

WDB001

*Available in black or white. Please specify colour when ordering.

GREAT MERCHANDISING SOLUTIONS



MERCHANDISING SOLUTIONS

We've got great ideas: Solutions for almost any challenge. If you don't see it here, we'll design a solution just for you! Maximize your sales and achieve your display objectives.

 **marketingIMPACT**
LIMITED

displaypeople.com

MULTI-PURPOSE ADJUSTABLE BIN & ACCESSORIES

Our Multi-Purpose Adjustable Bins are crystal clear and designed for showcasing bulk products. Place up to 3 dividers to maximize your sales and profitability. Hangs off pegboard, wire or slatwall using clear U-hooks (pg. 141). Our Bins offer a graphic track for signage. Bins and dividers are available in 3 sizes.



HOW DOES IT WORK?



COLOR OPTIONS



WIRE



PEGBOARD



SLATWALL



GLASS



NEW

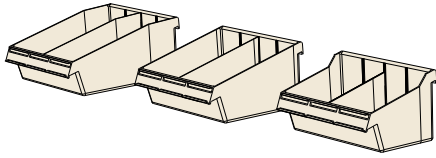

Multi-Purpose Adjustable Bins

Small Bin (7-1/2"L x 11-7/8"W x 5-7/8"H)	PEGBIN010
Medium Bin (10-1/4"L x 11-7/8"W x 5-7/8"H)	PEGBIN015
Large Bin (12-5/8"L x 11-7/8"W x 5-7/8"H)	PEGBIN020

*Dividers and Bins are available in clear, beige, black and white.
 **Please specify colour when ordering.

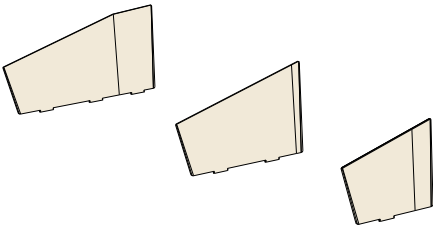

Multi-Purpose Adjustable Bin Dividers

Mounts onto Multi-Functional Tray to create up three compartments.

Small Divider	PDIV010
Medium Divider	PDIV015
Large Divider	PDIV020

Dividers and Bins are available in clear, beige, black and white.
 **Please specify colour when ordering.

NEW

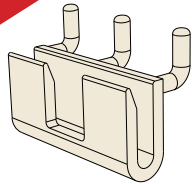

Pegboard / Slatwall Clear U-Hook

Used to hang Multi-Purpose Adjustable Bins to pegboard or slatwall.

2-1/4" W	PEG004
----------	--------

NEW

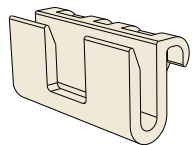

Wire / Flat Fence Clear U-Hook

Used to hang Multi-Purpose Adjustable Bins to wire or flat fence.

2-1/4" W	PEG006
----------	--------

NEW

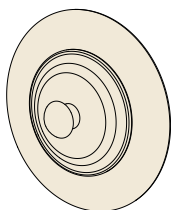

Grippa™ Mushroom Head Suction Cup

Used to hang Multi-Purpose Adjustable Bins to glass or smooth or flat surfaces.

	ACC950
--	--------

COSMETIC MERCHANDISING TRAY

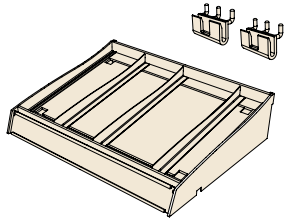
**Multi-Functional Tray**

Clear tray with flip front label holder. Locks together on sides. Moulded in crystal styrene. Includes 2 Peg/Slatwall Clear U-Hooks.

11-7/8"W x 8"D

COSMTRAY-01

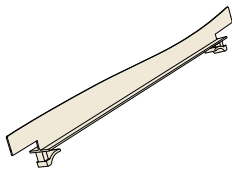
**Multi-Functional Tray Divider**

Mounts onto Multi-Functional Tray and slides left or right to adjust to product width. Moulded in clear styrene.

8"D x 1-1/8H

COSMDIV208

SLATWALL/PEGBOARD ACCESSORIES

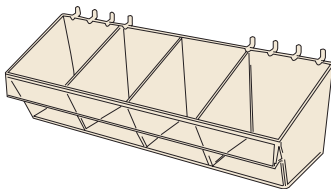
**Multi-Functional Divider Bin**

Showcase a variety of products at one time on pegboard or slatwall. Insert up to 3 dividers. Clear acrylic.

13"W x 4"D

PEGBIN001

**4" Dividers sold separately.*

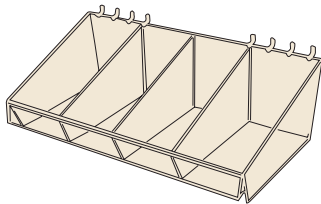
**Multi-Functional Divider Tray**

Showcase a variety of products at one time on pegboard or slatwall. Insert up to 3 dividers. Clear acrylic.

13"W x 7"D

PEGBIN002

**7" Dividers sold separately.*

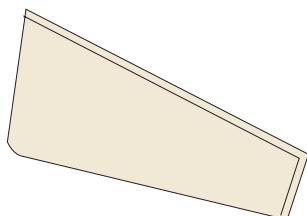
**Dividers (for Divider Bin / Tray)**

Add up to 3 dividers per bin or tray to create up to 4 compartments. Clear acrylic.

4"

PEGDIV001

7"

PEGDIV002



PEGBIN003

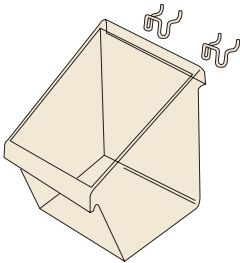

Bucket Display

Clear acrylic bucket can be used on pegboard, slatwall, or any flat surface. Includes two metal u-hooks.

4-1/2"W x 4"D x 7"H

PEGBIN003

7-1/2"W x 9"D x 9"H

PEGBIN004

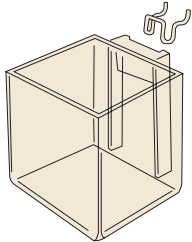

Cube Bin

Can be used on pegboard, slatwall, or as a counter display. Clear acrylic. Includes one metal u-hook.

4"W x 4"D x 4"H

PEGBIN005

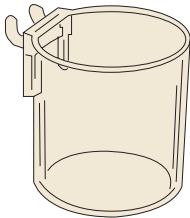

Cup Display

Use as a counter display or mount onto any pegboard or slatwall system using the attached hook. Clear acrylic.

4"D x 3-1/4"H

PEGCUP001

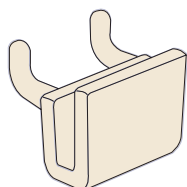

Clear Plastic U-Hook

Hang displays, bins and trays from slatwall or pegboard. Manufactured in high impact plastic.

1-1/4"W x 1/2"D x 3/4"H

PEG001

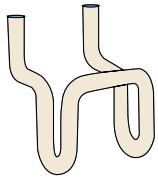

Metal U-Hook

Hangs displays, bins and trays from slatwall or pegboard. 148" hook diameter. Galvanized finish.

1-1/8"W x 1/2"D x 3/4"H

PEG002

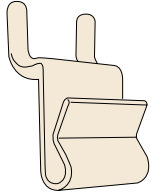

Slatwall / Pegboard Powerwing Clip

Holds corrugated displays flush to standard pegboard and slatwall. Prongs fit pegboard with 1" holes on centre.

PW3550

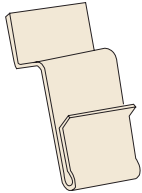

Slatwall Upperwing Clip

Holds corrugated displays. Upper lip fits most standard slatwall.

PW3560

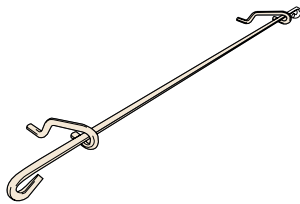

Power Bar

Allows for attaching corrugated displays to most shelving. Adjustable arms.

15-1/2" L Adjustable

PW3590

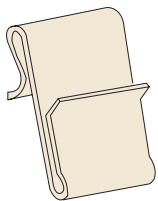

Corrugate Powerwing Clip

Hold corrugate displays on both Power Wing or Power Bar. Design for easy installation.

1-1/4"L x 2-1/4"H

PW3570

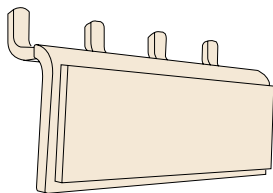

Pegboard / Slatwall Adapter

Holds lightweight displays on pegboard or slatwall. Fits standard 1/4" pegboard holes. Comes with permanent adhesive.

3-1/2"L x 1-1/4"H

PW3575

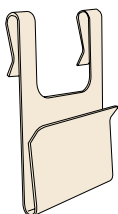

Warehouse Powerwing Clip

Holds displays securely in retail warehouse environments. Fits most standard warehouse uprights.

1-1/2"L x 2-3/8"H

PW3580

COOLER MERCHANDISING RACKS

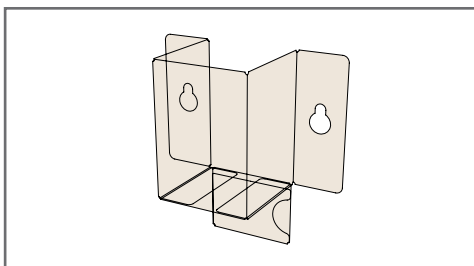

Beverage Holder

Made from clear copoly. Includes 2 standard suction cups. Product Area: 2½" x 3½" x 2¾" (Fits 2¾" diameter can), Label Area: 2-½" x 3".

BEV005

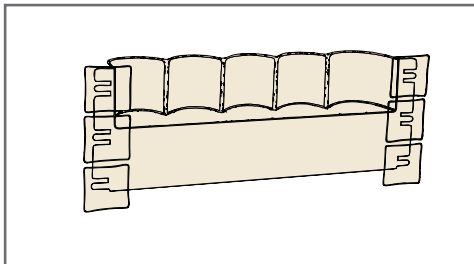

Cooler Merchandiser Rack - 20 oz.

Made from break resistant PET plastic. Fits 5 20oz. bottles or 5 24oz. cans. Includes 6 standard suction cups. Label Area: 14-½" x 2-½", Diameter: 2-¾".

BEV002

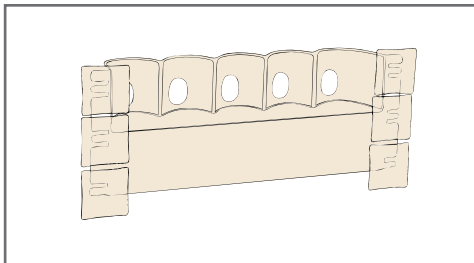

Cooler Merchandiser Rack - 16 oz.

Made from break resistant PET plastic. Fits 5 16oz. bottles. Includes 6 standard suction cups. Label Area: 13-¼" x 2-½", Diameter: 2-⅝".

BEV001

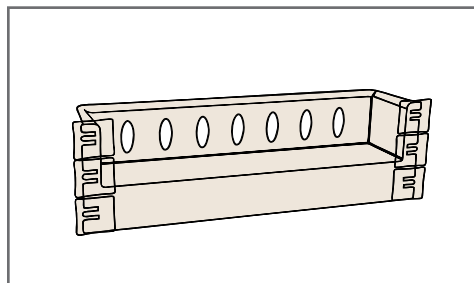

Merchandiser Rack - 6

All purpose display made from break resistant PET plastic. Includes 6 power suction cups. Product Area: 3-¾" x 18-½", Label Area: 18" x 2".

BEV004

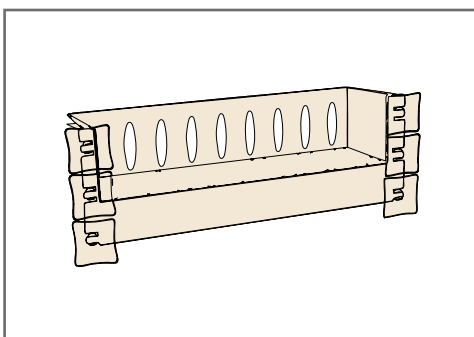

Merchandiser Rack - 4

All purpose display made from break resistant PET plastic. Includes 4 standard suction cups. (Rack can hold up to 6 suction cups to accommodate heavier products). Product Area: 3-¾" x 16-½" Label Area: 15" x 1".

BEV003

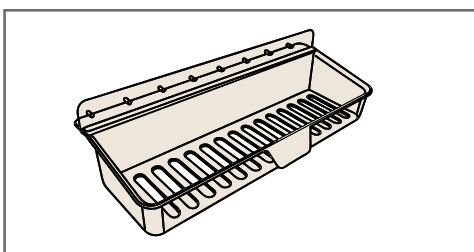

Shelf Extender

Made from break resistant PET plastic. Fits any standard sized store shelf. Product Area: 15" x 4-¼" x 3", Label Area: 14-½" x 1", Bar Code Area: 2-¼" x 1".

SHEEXT001



PRODUCE BINS

GIVE THE LOOK OF A FARMERS MARKET AMOUNT-OF-PRODUCT, WHILE USING VERY LITTLE INVENTORY.

- Full functioning merchandising bins that fold for convenient shipping and storage.
- Accommodates large and heavy weight products



HOW DOES IT WORK?

PRODUCE BIN MERCHANDISER

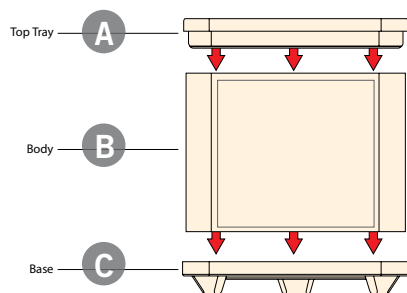

PRODUCE BINS

Top Tray (A) and Bottom Base (C) are vacuum formed in black ABS plastic.

Available in:

Full Size: 47" L x 40" W x 35" H

Half Size: 36" L x 24" W x 36" H.

Walls can be silkscreened with graphics on all sides or on the front side only with kraft on remaining sides.

ASSEMBLING YOUR PRODUCE BIN:

- 1 Lay base on floor.
- 2 Fold cardboard into box shape.
- 3 Place cardboard into slots on base.
- 4 Place top tray on cardboard, aligning slots.

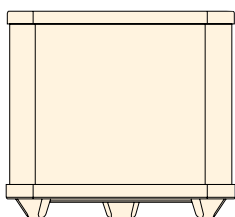
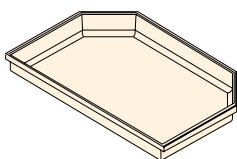

Small Produce Bin

Small Produce Bins are available in kraft colour. Top flat surface tray and bottom base are available in black.

Small Produce Bin Set (Body Size — 36" L x 24" W x 36" H) BINPRODUCEH

*Base, Body and Flat Top Tray included in produce bin set

Small Produce Bin Flat Top Tray (Tray Size — 36" L x 24" W x 3" D) BINH001

Small Body COR SMA

Small Produce Bin Base BINHB001

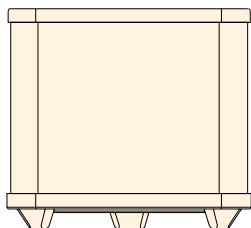
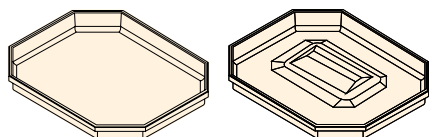

Large Produce Bin

Large Produce Bins are available in kraft colour. Top tray with middle riser and bottom base are available in black.

Large Produce Bin Set (Body Size — 47" L x 40" W x 35" H) BINPRODUCEF

*Base, Body and Flat Top Tray included in produce bin set. Please Specify desired tray

Flat Surface Tray (47" L x 40" W x 4" D) BINF001

Tray with Middle Riser (47" L x 40" W x 4" D) BINR001

Large Body CORLAR

Large Produce Bin Base BINB001



COOL-ADS™

Reach shoppers where they make their purchase decision!

INCREASE SALES WITH SOUND, LIGHT & TOUCH

Cool-Ads™ deliver your selling message right at the the cooler — literally right in the shopper's hand! you can add motion-sensing light and a audio message for even more impact.

Features & Benefits

- Cool-Ads™ actually replace or attach the cooler door handle
- Reach shoppers at the moment of purchase
- Optional LED lights and customized audio message
- Light / sound triggered by an infra-red motion sensor from 3 feet away (Battery-Operated)



COOL-ADS™ Plastic Handle

Cool Ads™ actually replace the cooler door handle. Reach shoppers at the moment of purchase. Use with optional Sound and Light Module and or Cool Coupon Module.

CDH002



COOL-ADS™ Sound and Light Module

Customize your audio message and draw attention to your products with four flashing LED lights. The Light and Sound Module is triggered by an infra-red motion sensor from three feet away. Battery operated using 8 AA batteries located in an easily accessible compartment.

CDHA002



COOL-ADS™ Coupon Accessory

Use 3" x 3" coupon pads and stick to the removable coupon backer. Enhance the product ads with coupons as desired, or cross market related products. Install in seconds to your Cool Ads handle by simply changing the top end cap. Extremely cost effective hardware that will greatly increase promotional response. Coupon back can slide out when not in use.

CDM004

INLINE MERCHANDISING

1 x2 Satin Aluminum Posts with Hinge Framed Slatwall

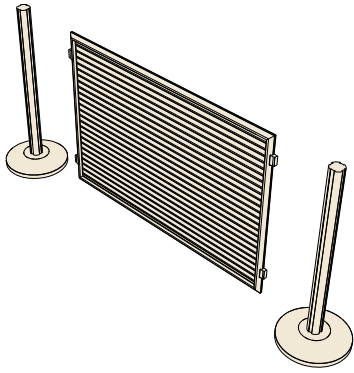

2 Add Optional Signage and Merchandising Bowl

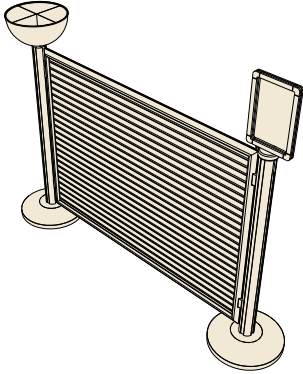

3 Customize Your Display with Various MIL Products such as:

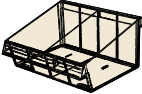

Multi Purpose Adjustable Bins

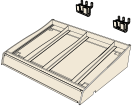

Multi Functional Tray



Magazine Pocket Holder

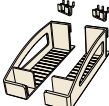

Shelf Frame Holder

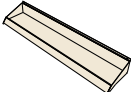

Metal Tray



DVD / Video Games Pusher Box

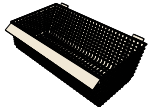

Metal Basket



NEW

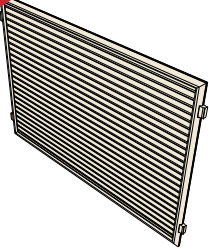

Satin Aluminum Hinge Framed Slatwall

Use in conjunction with 2 of our Satin Aluminum Posts to build a double-sided, portable, merchandising slatwall display.

49"W x 35"H
SLAPAN001

NEW

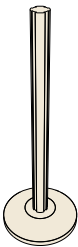

Satin Aluminum Post with Grey Base

A versatile and attractive option for floor standing Point of Purchase merchandising. These posts feature a dovetailed attachment system, allowing you to build your own display with our various modular components. All posts feature a rubberized non-slip base which also serves as a floor protection coating.

40-1/2"H x 14" Diameter Base (Centre Post)
CPOST001

40-1/2"H x 14" Diameter Base (End Post)
EPOST001

NEW

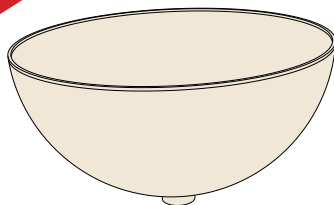

Merchandising Bowl

Add our Merchandising Bowl to the top of a Satin Aluminum Post to clearly display the products within. A great way to increase impulse sales!

13-3/8" diameter x 6-1/4" H

MB0001



NEW

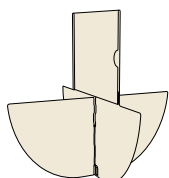

Bowl Divider with Sign Holder

Make your display even more eye catching by using our Merchandising Bowl with dividers and signage!

7-1/2"W x 5-1/2"H

SHODIV005

NEW

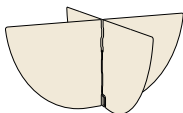

Bowl Divider

For use within our Merchandising Bowl to showcase up to 4 varieties of products.

SHODIV001

NEW

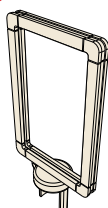

Satin Aluminum Signholder with Swivel Mount

Finish your Satin Aluminum Post with a matching top mounted sign frame. Frames are mounted to a swivel bracket allowing you to direct your signage up to 360 degrees.

6-1/2" x 10-1/2" (Graphic Area)

SHOVSM0711

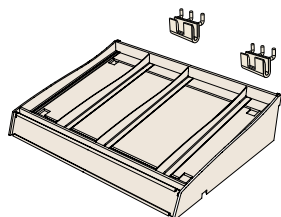

Multi-Functional Tray

Clear tray with flip front label holder. Locks together on sides. Moulded in crystal styrene. Includes 2 Plastic U-Hooks. Label Insert Dimensions 11-7/8"W x 1-3/16"H.

11-7/8"W x 8"D

COSMTRAY-01

NEW

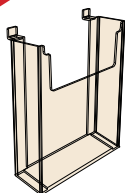

Magazine Pocket Holder

Injection molded. Mounts onto slatwall to display standard size 8-1/2" x 11" magazines.

8-1/2"W x 11"H

BH0320

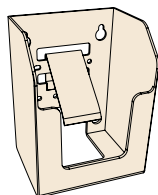

DVD / Video Games Pusher Box

Front loading pusher allows DVD's / Video Games to be neat and visible at all times. Molded in crystal styrene. Various mounting options include suction cup, shelf, pegboard and slatwall. 6 DVD capacity.

5-25/32"W x 7-11/16"H

DVDB100

NEW

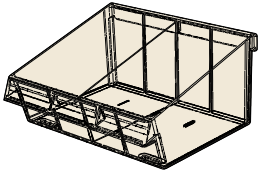

Multi-Purpose Adjustable Bin

Small Bin (7-1/2"L x 11-7/8"W x 5-7/8"H)	PEGBIN010
Medium Bin (10-1/4"L x 11-7/8"W x 5-7/8"H)	PEGBIN015
Large Bin (12-5/8"L x 11-7/8"W x 5-7/8"H)	PEGBIN020

*Dividers and Bins are available in clear, beige, black and white.
**Please specify colour when ordering.

NEW

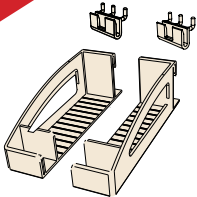

Slatwall / Pegboard Frame Holder

Linens, books, picture frames and more...these shelves hold a variety of merchandise.

10" L x 2-3/8" W	SHEFR001
------------------	----------

*Hardware sold seperately.

NEW

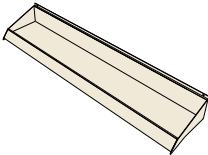

Metal Tray

48"W x 8"D	TRAYMET001
------------	------------

NEW

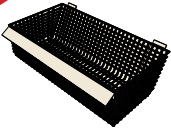

Metal Basket

24"W x 11"D x 6"H	BASMET001
-------------------	-----------

SKID FENDER

Double-duty fenders protect your skid and promote your product at the same time!

Skid Fender
HOW DOES IT WORK?

Simply slide apart to the desired length and connect the interlocking corners. Don't forget to take advantage of this convenient advertising space!

Heavy-duty construction to resist bumps.



NEW

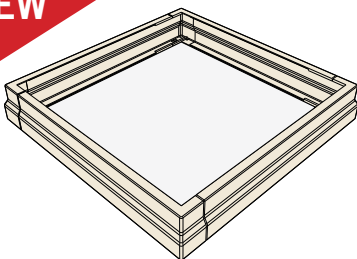





Skid Fender

Skids in a store can be an eyesore. Worse, they can be dangerous. Customers may trip over a corner or bump them with a shopping cart. Our Skid Fenders protect both product and shopper by shielding the sides and corners with a sturdy, attractive bumper. They're also a new space for advertising. Interlocking bumpers expand from 31" to 55" and can be linked to wrap around any size skid. Black and red available.

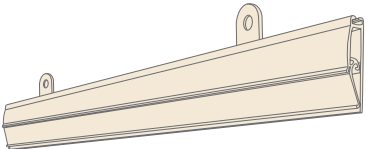
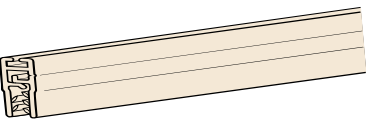
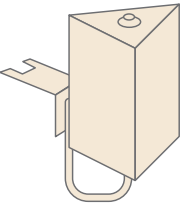
SKIDFEND001R

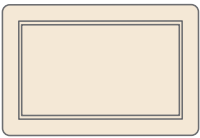

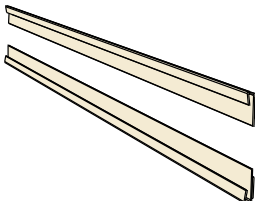
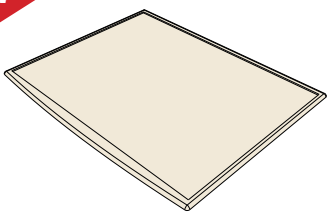
MORE MERCHANDISING IDEAS

	<h3>Snap Banner Track</h3> <p>Hanging signage is a snap! Just snap the clear track right onto the edge of your sign. Now you're ready to slide in eyelets, and hang the sign from the ceiling, or affix the track directly to a wall with double-sided tape.</p> <table border="1"> <tr> <td>Snap Banner Track (Standard Lengths up to 48")</td> <td>SHE2189</td> </tr> <tr> <td>Hanging Eyelet</td> <td>SHE2189EYE</td> </tr> </table> <p>*Available in Black or Clear.</p>	Snap Banner Track (Standard Lengths up to 48")	SHE2189	Hanging Eyelet	SHE2189EYE	
Snap Banner Track (Standard Lengths up to 48")	SHE2189					
Hanging Eyelet	SHE2189EYE					
	<h3>Mercury Banner Hanger</h3> <p>Snaps to hold banners securely.</p> <table border="1"> <tr> <td>48" L (clear)</td> <td>SHE2180CLEAR48</td> </tr> </table>	48" L (clear)	SHE2180CLEAR48			
48" L (clear)	SHE2180CLEAR48					
	<h3>3 Face Shelf Spinner</h3> <p>Customers can turn the Shelf Spinner for three panels of information. Easily mounts to a standard perforated shelf. Holds three cards 2-3/4"W x 5-1/4"H.</p> <table border="1"> <tr> <td></td> <td>SHESPN</td> </tr> </table>		SHESPN			
	SHESPN					
	<h3>Check Out Mat</h3> <p>For easy countertop display promotions, photos, menus and more. Lift the clear panel to change your message in seconds. Rugged construction with a non-slip bottom. Viewable window 13-3/4"W x 9-5/8"H.</p> <table border="1"> <tr> <td></td> <td>CHKMAT</td> </tr> </table>		CHKMAT			
	CHKMAT					
	<h3>J-Track Signholder</h3> <p>Secures in place with permanent adhesive. Holds material up to 1/4" thick. Clear track measures 48" in length and can be cut to size as desired.</p> <table border="1"> <tr> <td></td> <td>SHE2167CLEAR</td> </tr> </table> <p>* Custom colours are available. Minimum quantities apply.</p>		SHE2167CLEAR			
	SHE2167CLEAR					
<div style="background-color: red; color: white; padding: 5px; display: inline-block;">NEW</div> 	<h3>Deskwindo™</h3> <p>Bring the sell power of advertising to virtually any desktop, countertop, or checkout. Showcase your fliers, sales, and new products in this sleek, durable, and low profile advertising tool.</p> <table border="1"> <tr> <td>8-1/2" x 11" Window</td> <td>WIN8511BK</td> </tr> <tr> <td>16-5/8" x 11-3/4" Window</td> <td>WIN1611BK</td> </tr> </table> <p>*Only available in black.</p>	8-1/2" x 11" Window	WIN8511BK	16-5/8" x 11-3/4" Window	WIN1611BK	
8-1/2" x 11" Window	WIN8511BK					
16-5/8" x 11-3/4" Window	WIN1611BK					

STANDARD CORRUGATED DISPLAYS

Quick and easy assembly. Most dump bins can be flipped for use of two depths.

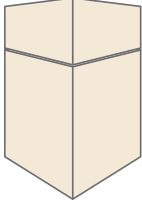
Custom printing available.

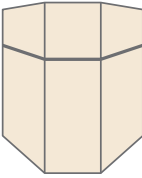
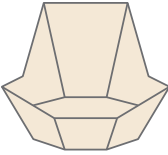
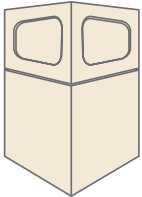
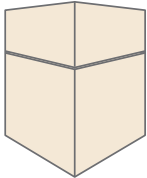
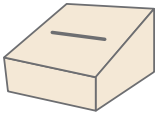
	<h3>Rectangular Bin</h3> <p>14"W x 18"D x 30"H SDB001</p>	 <p>SDB004 Countertop Display Bin with custom printing.</p>
	<h3>Hexagonal Dump Bin</h3> <p>9"W x 9"D x 30"H SDB003</p>	
	<h3>Countertop Display Bin</h3> <p>11"W x 6"D x 10"H SDB004</p>	
	<h3>Square Window Bin</h3> <p>14"W x 14"D x 28"H SDB006</p>	
	<h3>Square Bin</h3> <p>13"W x 13"D x 30"H SDB002</p>	
	<h3>Ballot Box</h3> <p>10"W x 8"D x 8½"H SDB005</p>	



BEVERAGE SYSTEMS

We've brewed a new blend of accessories that bring style and functionality to any retail, food service, or office coffee setup.

marketing**IMPACT**
LIMITED

displaypeople.com

WHOLE BEAN MERCHANDISING

Entice your customers by showing off your whole bean coffee in our classy and stylish Merchandising Bins. All of our Bins feature a reliable, patented, high polished, cast aluminum Dispensing Ball.

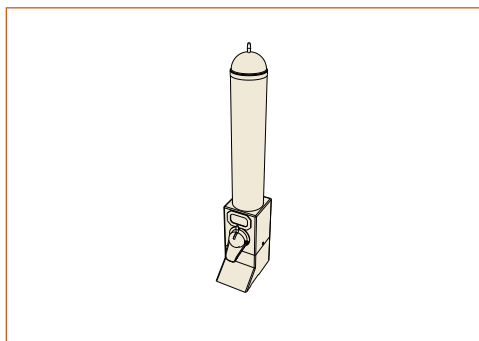

501 Whole Bean Free Flow Coffee Bin

Our 500 Series of Whole Bean Free Flow Coffee Bins utilize our cast aluminum Dispensing Ball on a counter top or wall mountable base. Features chrome plated sign-card holder and lid, branding can easily be added to tubes.

10"D x 6-3/8"W x 36"H	FF-501-18 (18" Tube)
10"D x 6-3/8"W x 42"H	FF-501-24 (24" Tube)

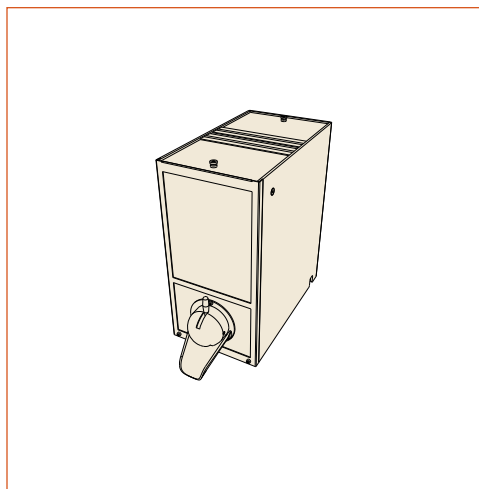

700 Series Whole Bean Free Flow Coffee Bins

Create your own whole bean coffee merchandising system! An elegant European style finish with our cast aluminum Dispensing Ball. Ball Back Plates are available in a hammered gold finish, or brushed stainless steel.

14"D x 8"W x 16"H	CAPACITY: 10-12Lbs	FF-704
14"D x 6"W x 21"H	CAPACITY: 12Lbs	FF-714 (Dual Ball Bin)
14"D x 6"W x 21"H	CAPACITY: 12Lbs	FF-715
14"D x 6"W x 14"H	CAPACITY: 5Lbs	FF-716
14"D x 6"W x 16"H	CAPACITY: 8Lbs	FF-717

*Please specify Ball Back Plate when ordering.

GRAVITY POT AND MERCHANDISE STANDS

We have everything you need to create your own Office Coffee or Self-Serve System no matter how big or small your operation is.

Thermal Gravity Pot with Single Gravity Pot Stand and Condiment Tower



Thermal Gravity Pot with Double Gravity Pot Stand

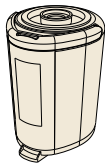

Thermal Gravity Pot Beverage Dispenser®

Zojirushi 2.5L capacity, glass lined, NSF rated. Use in conjunction with our TR-59, TR-74, and TR-75 Riser Stands.

DIMENSIONS: 7-3/8" D x 11-7/8"H

AYAE25N



Condiment Tower

Condiment Tower with 4 removable trays. TR-7 works as a stand-alone unit or with our TR-74 and TR-75 Pot Stands to build your own modular beverage station.

8-11/16"D x 8-1/16"W x 14"H

TR-7



Short Single Gravity Pot Stand

Single Gravity Pot Stand accented with gold trim and features an adjustable high-capacity spill tray. Use with AY-AE25N 2.5L Thermal Gravity Pot.

8-11/16"D x 8-1/16"W x 14"H

TR-59

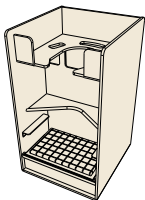

Single Gravity Pot Stand

Our most popular Gravity Pot Stand. Features an adjustable high capacity spill tray, and accented with gold trim. Use with AY-AE25N 2.5L Thermal Gravity Pot, and a TR-7 to build your own modular beverage station.

8-11/16"D x 8-1/16"W x 18"H

TR-74

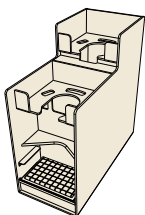

Double Gravity Pot Stand

When one pot is not enough! Features an adjustable high capacity spill tray, and accented with gold trim. Use with two AY-AE25N Thermal Gravity Pots, and a TR-7 to build your own modular beverage station.

8-11/16"D x 8-1/16"W x 18"H

TR-75

CONDIMENT TRAYS

Our Condiment Trays come in all different shapes, sizes, and capacities. Choose the tray that works for you or let us design one for you!



CT-4



CT-13



CT-15

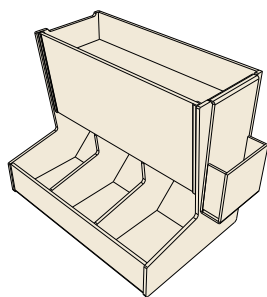

Condiment Tray with Stir Stick Caddy

Keep your condiments organized and accessible. Can be used as a stand-alone unit or linked together to form any size system. Features a clear front window, and removable stir stick caddy.

(2 Compartments)	7-13-16"D x 9"W x 9-13/16"H	CT-2
(3 Compartments)	7-13/16"D x 12-7/8"W x 9-13/16"H	CT-3
(4 Compartments)	7-13-16"D x 16-11/16"W x 9-13/16"H	CT-4

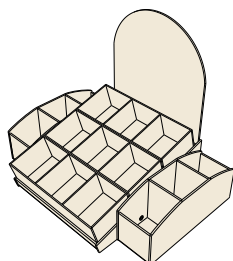

Single Tier Condiment Tray

An all-encompassing condiment organizer with 3 removable, 3 compartment trays, and flanked by 2 detachable, 3 compartment cup/lid/stir stick caddies. Signage is removable.

15-3/8"D x 21-1/2"W x 17-3/8"H	CT-13
--------------------------------	-------

* Custom branding available. Minimum quantities apply.

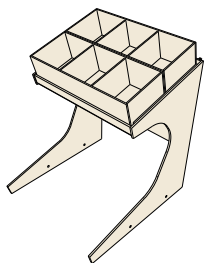

Second Tier Condiment Tray Add-On

Take your CT-13 to a new level with this Second Tier Add-On, complete with 2 removable, 3 compartment trays. Accommodates your CT-13 signage.

15-11/16"D x 13-5/16"W x 18-3/16"H	CT-14
------------------------------------	-------

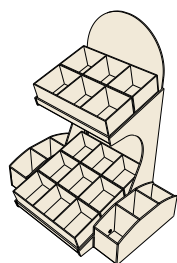

Two Tier Condiment Tray

Our largest Condiment Tray, built for high traffic beverage stations. Complete with 5 removable, 3 compartment trays, flanked by 2 detachable, 3 compartment cup/lid/stir stick caddies and signage.

15-11/16"D x 21-7/16"W x 29-3/8"H (with signage)	CT-15
--	-------

* Custom branding available. Minimum quantities apply.

CUP / LID ORGANIZERS

Stay organized and add to the convenience of your daily operations with our storage solutions.

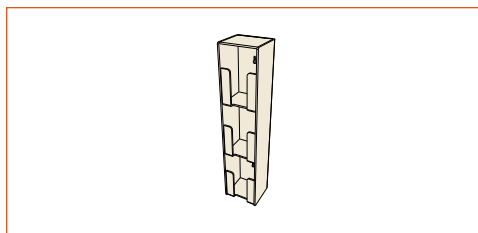

3 Level Lid Holder

Accommodates up to 3 variations of lids. Works as a stand-alone unit or use the eyelets for wall mounting or hook and loop for mounting to equipment.

4-7/16"W x 5"W x 22-7/8"H

LH-100-1

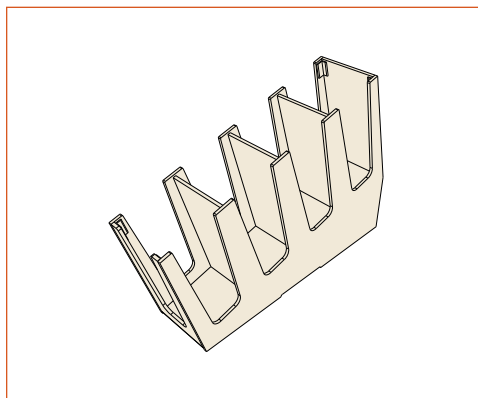

Sloped Cup / Lid Holder

Great for narrow spaces, our Sloped Cup/Lid Holders work with cups / lids up to 3-7/8" in diameter.

14"D x 4-1/4"W x 11-1/8"H (3 Cavity)

LH-100-9

18"D x 4-1/4"W x 12-3/16"H (4 Cavity)

LH-100-10

22"D x 4-1/4"W x 13-1/4"H (5 Cavity)

LH-100-8

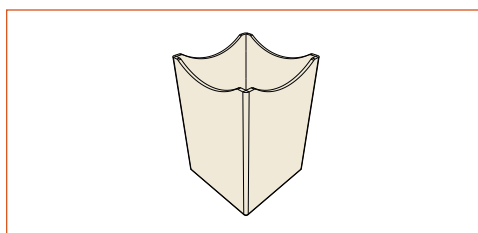

Stir Stick / Straw Holder Add-On

Use as a stand-alone unit or in conjunction with our LH-100-8/9/10 Sloped Cup / Lid Holders to keep stir sticks / straws neat and tidy.

3-3/4"D x 3-3/4"W x 5-5/8"H

LH-100-SH-1

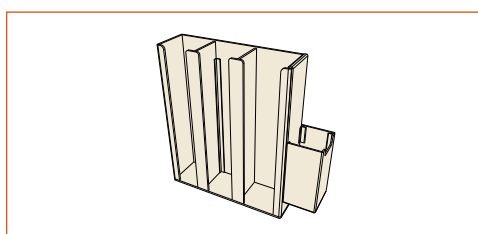

3 Silo Cup / Lid Holder with Stir Stick Caddy

Large capacity cup / lid holder with clip-on Stir Stick/Straw Caddy.

3-15/16"D x 16-3/4"W x 16"H

LO-3

ACCESSORIES

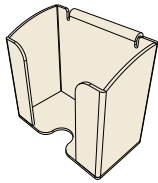

Clip-On Hot Beverage Sleeve Holder

Our injection molded sleeve holder clips onto substrates up to 3/16" thick, such as a most of our Cup/Lid Holders. Can also be used as a stand-alone unit.

3-1/2"D x 5-13/16"W x 5"H

SLVH-0001

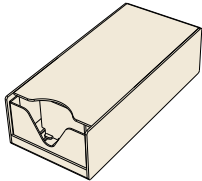

Hot Beverage Sleeve Pusher

Easy to access and refill, keeps your cup sleeves front facing and easily accessible with a built-in spring loaded pusher.

12-1/2"D x 6-1/4"W x 3-1/2"H

SLVH-0002

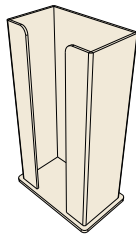

Hot Beverage Sleeve Holder

Keeps your cup sleeves organized and available at your finger-tips.

3-1/2"D x 5-3/4"W x 10-3/16"H (Clear Acrylic)

HBSH-A

3-1/2"D x 5-3/4"W x 10-3/16"H (Black Styrene)

HBSH-S

*Custom sizes available. Minimum quantities apply.

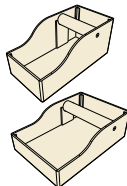

Espresso Knock Boxes

Our Knock Boxes feature an ergonomic design complete with a cushion lined Knock Bar. Perfect for hiding away in a drawer, yet stylish enough to keep on a counter top.

6-1/8"W X 12"D X 5-1/2"H

BB01

8-1/4"W X 12"D X 4"H

BB02

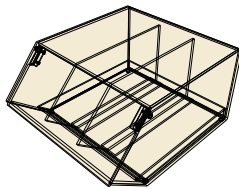

Pastry Case

Fabricated from clear acrylic, complete with dividers and the ability to stack the cases one upon the other.

12" W X 14DX 7" H

BD-12

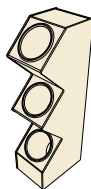

Cutlery Tower

Great for cutlery and condiments alike; the Cutlery Tower can be positioned either vertically or horizontally. Featuring 3 removable stainless steel canisters and a sliding back door for easy cleaning and storage.

5" 7/8W X 8" 5/16 D X 23" H

CT-CS-01

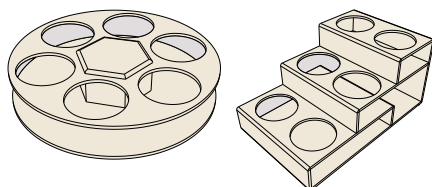

Syrup Racks

Made from Food Grade Styrene, our Syrup Racks keep syrup bottles organized and easily accessible.

8" 1/4W X 13D X 6 1/4 H

SR-1-3

11 7/8 Diameter X 3"H

RSR-12-6

LIGHTING SYSTEMS



LIGHTING SYSTEMS

Innovative, versatile solutions from the simplest to the most complex retail merchandising and display requirements.

 marketing**IMPACT**
LIMITED

displaypeople.com

EFFICIENT & INNOVATIVE RETAIL LIGHTING SOLUTIONS

According to the Lighting Research Center, the integration of lighting on a shelf or fixture at the point of purchase increases the likelihood of sale by 40%. And LED's save energy!

Integration of lighting elevates the brand image and greatly improves visibility of the products on display.

FEATURES & BENEFITS OF RETAIL LIGHTING

- Saves energy & maintenance
- Great category destination driver
- Superior color range for illuminating graphics
- Light weight molded plastic design
- Easy retrofit installation
- 5-Year Warranty

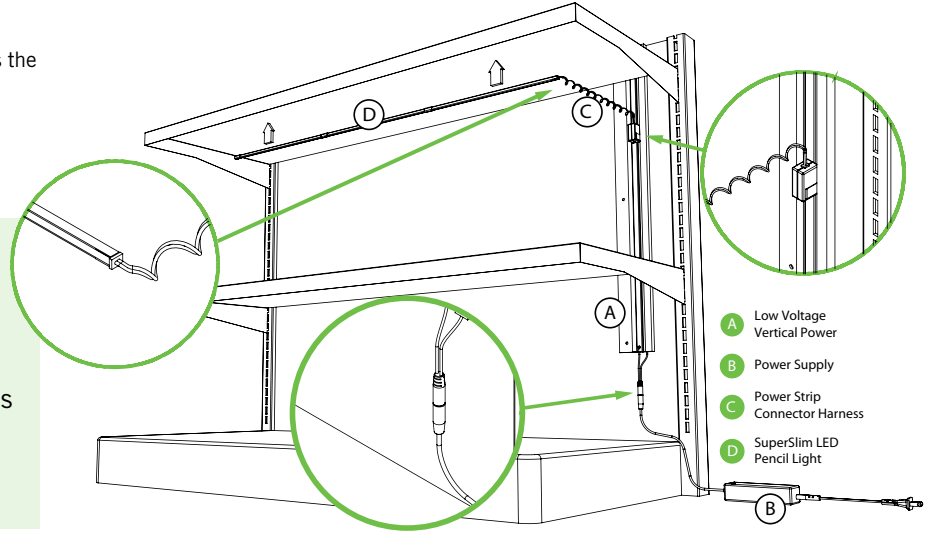

Super Slim LED Pencil Light

Customizable to meet your needs! LED board is contained within a clear plastic covering. LED strips are offered in multiple lengths. Connect up to 12 Pencil Lights in a row. Mounting options: Magnetic tape Double sided tape Brackets. Light Output: 105 Lumens / 12 LED's per foot. Colour Temperature: 6000K - 7000K Longevity: 50,000 hours.

4 Ft. Shelf Kit

LEDPEN001

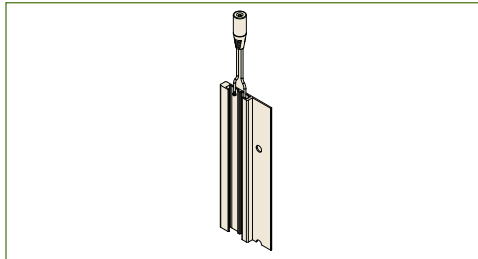

Low-Voltage Vertical Power Strip

Extruded plastic rail can be customized to any length between 24" and 84". Can be mounted vertically against pegboard or horizontally under a shelf. Mounting options: Double sided tape, Push Pins or Metal hardware.

LVPS001

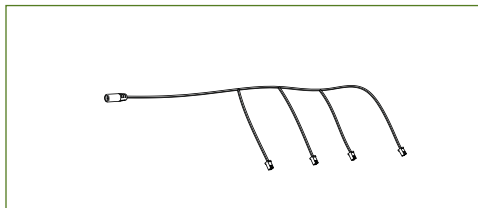

Low Voltage Wire Harness

For use in compact spaces. Customizable up to 7 connections

LVNH001

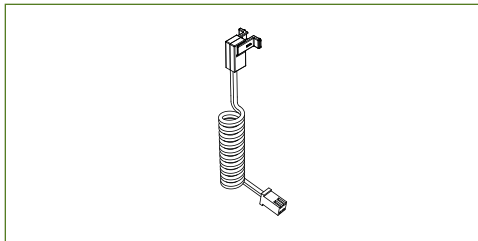

Power Strip Connector Harness

Connects a row of Super Slim LED Pencil Lights to a Vertical Power Strip.

PSCH001

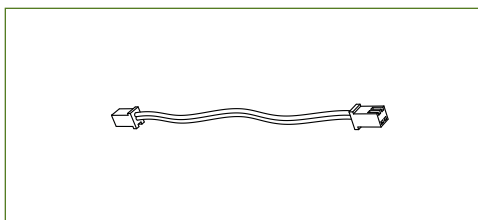

Male / Female LED Connector

Adds flexible space between Pencil Light segments

MFLED001

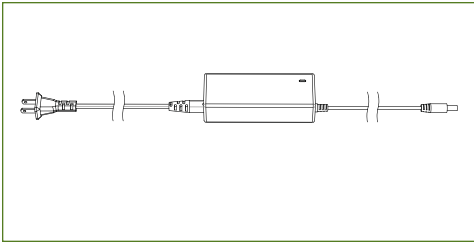

Power Supply

TYPE: Class 2
 Input Voltage: 110Vac/220Vac
 Output Power: 100W
 Output Voltage: 24Vdc

*Optional 80W and 60W power supplies available
 *Option to connect to adjacent power supply units (max 11)

POWSUP001



Outdoor High Output LED Tape

Outdoor High Output LED Tape that provides ample illumination for residential, retail, and any other outdoor application. 54 Watts, 3850 Lumen, 5 Meters Long.

Cool White

LED001-CW

Natural White

LED001-NW



LED Indoor Strip Tape

The LED STR Series features 12" linkable, no shadow, end to end joinable sections. Provides high performance illumination for commercial and residential illumination.

LEDS001

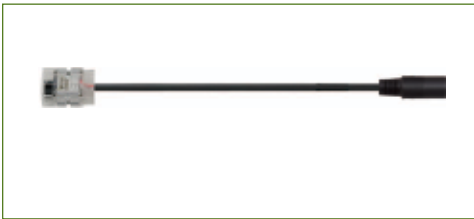

12" Power Feed

12" Power Feed, 2.1 DC Jack to Strip Connector

LEDACC001



Wire Splice Extension Kit

Wire Splice Extension Kit for use with single colour indoor LED strip lights.

LEDACC002

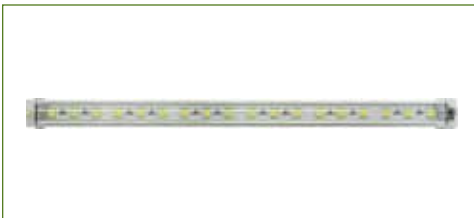

Indoor LED Pencil Light

Colour Changing LED Indoor Tape Light, normal output, 12" linking sections, 3.1Watts/Foot, 120° viewing angle, 18 LED's/12", 70 Lumen/12".

LED5001



Outdoor LED Tape

The LED STR Series features 12" linkable, no shadow, end-to-end sections. Provides high performance illumination for commercial and residential illumination.

LEDR001





Coloured LED Ribbon

Available in red, blue, green, and yellow. Cut to required lengths in 4" increments.

LEDT

*Available in assorted colours. Call for details. Minimum quantities may apply.



Indoor Colour Changing LED Tape

Normal output, 12" linking sections, 3.1Watts/Foot, 120° viewing angle, 18 LED's/12", 70 Lumen/12".

LED002-12



60 Watt LED Plugin Driver

This LED Plugin Driver comes with a cord, plug and a 2.1 D.C. jack. Suitable for Indoor LED Tape and LED Strip.

POWER SUPPLY

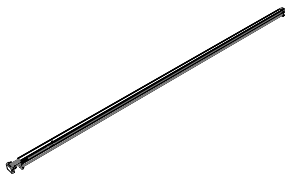

Universal Undershelf Light (compression fit)

Impact LED lighting for hot spot lighting in Beauty & Cosmetics. Lots of lumens for visual impact. SUPER easy to install...like shower curtain rod...spring activated on inside of shelf. Energy savings and maintenance free...50,000 hour life.

LEDUNDS01

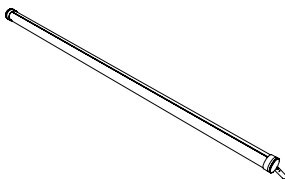

Universal LED Lit Cornice

Interlocking cornice frame creates soft and elegant curves, inviting to navigate the entire length of the aisle. Portrait style extended cornice features LED lights uniquely configured to emit a warm and consistent flow of directional lighting on all shelves—top to base. Segmentation plaques float in between interlocking cornice to help consumers navigate aisle and quickly locate desired product segment.

UNILED001

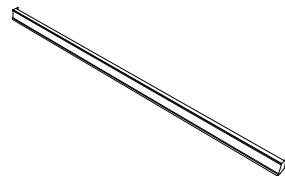

Trio Edge Shelf Light

Triple light projection: upward on product, downward on product, and shelf edge graphics. Highlights segmentation graphics on front channel. Universal design: spring clips to most dairy shelves (even in refrigerated environments), and can simply be daisy chained together. Adaptable with standard UPC price tags and secondary store media devices.

TESL001



CUSTOM DISPLAYS



CUSTOM DISPLAYS

Innovative, versatile solutions from the simplest to the most complex retail merchandising and display requirements.

 **marketing**IMPACT
LIMITED

displaypeople.com



COUNTER DISPLAYS

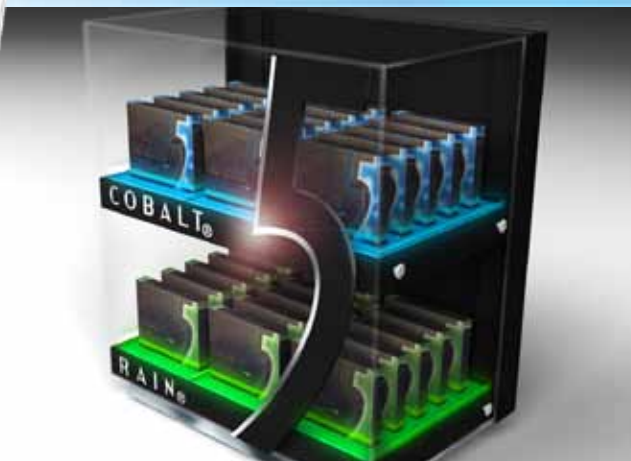

COUNTER DISPLAYS



COUNTER DISPLAYS



FLOOR DISPLAYS



FLOOR DISPLAYS



SIDEWINDERS



SIDEWINDERS



HANGING RETAILERS & EAR MUFFS



BIRD BATH DISPLAYS



SKIDS AND GONDOLAS



VACUUM FORMED DISPLAYS

HOW DOES IT WORK?

1. Modular Bin



2. Stack and Fasten



3. Add Drawers and Signage

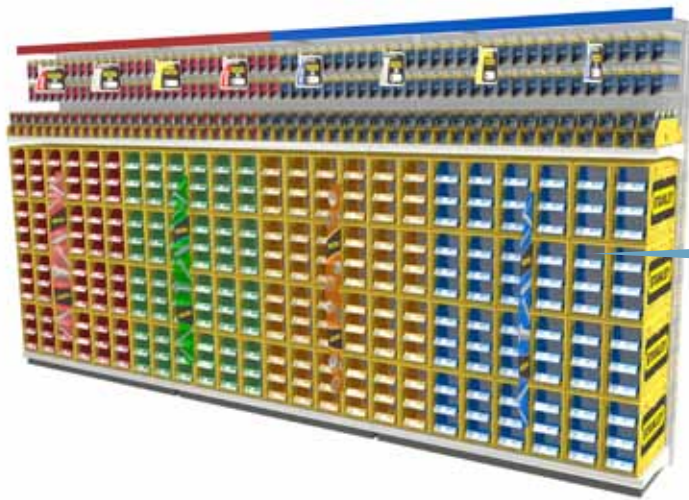

INJECTION MOULDED MODULAR DISPLAYS



CUSTOM ACRYLIC

LIMITLESS POSSIBILITIES

Count on Marketing Impact for POP solutions that are eye-catching and sales-building. Our creative department will work with you to develop concepts and graphics from the ground up. We can also work with your agency and build displays to existing specifications. We will use the right materials and the best processes for cost-effective, high-impact results. Our custom shelf-management systems will help you dominate your category. Don't forget to ask us about our logistics and fulfillment services too!

Call us today and let Marketing Impact be your source for effective display and merchandising.



INDEX

SIGNHOLDER SYSTEMS

1 Piece Moulded Aisle Marker	44	Clip-On Spring Signholder	53	Shelf Bin Holder	29
2-Way Sign Grip Clip	49	Clip-On Stem Base	21	Shelf Locking Sign Clip	29
3-Way Copoly Signholder	18	Clip-On Stem Base for Wire Grid / Basket Frame	21	Shelf Spring Sign Clip	29
3-Way Counter Top Signholder	18	Clip-On Wire Signholder	54	Shelf Top Centering Swivel Mount	28
3-Way Floor Standing Signholder	32	Coupon Holder	30	Shelf Top SuperGrip®	40
3-Way Frame Connector	18	Curly Wire Clips	53	Shopping Cart/Wall Mount Sign Holder	19
3-Way Pillar Floor Standing Sign	33	Custom Frames (Corners and Edging)	44	Sign Frame with Adjustable Telescopic Pole & Center Stem Base	34
3-Way Signholder Kit	18	Double Clip-On Signholder	53	Sign Frame with Centre Stem Base	35
4-Sided Signholder	42	Double Duty Shelf Channel Signholder	49	Sign Frame with Flat Base	34
4-Way Frame Connector	17	Double Loop UPC / Label Holder	52	Sign Frame with Gondola Stem Base	37
4-Way Frame Kit	17	Dual Frame	45	Sign Frame with Magnetic Base	35
90° Elbow	22	Dual Frame Connector	45	Sign Frame with Magnetic Stem Base	36
Aisle Marker	44	Extruded Signholder Clip	48	Sign Frame with Parallel Magnetic Stem Base	35
Aisle Signholder with C-Clamp	30	Fish Tip™ or Flip Scan Hook	45	Sign Frame with Pegboard Extension Mount	20
Angled Card Holder	50	Flat Base	26	Sign Frame with Self-Centering C-Channel Mount	36
Basket Clip	48	Flat Shovel Base	26	Sign Frame with Self-Centering Undershelf Mount	36
Bottle Top Holders	19	Floor Standing Signholder	33	Sign Frame with Self-Centering Undershelf Swivel Mount	37
Carton/Basket Clip	25	Fold N Hold Covered Ticket Holder	52	Sign Frame with Shovel Base	34
C-Channel Pivoting Connector	24	Fold N Hold Flag Signholder	49	Sign Frame with Shovel Base & Stem	36
Center Stem Base	26	Fold N Hold Shelf Channel Flush Signholder	49	Sign Frame with Suction Cup	37
Channel Clip Mount	23	Fold N Hold Ticket Holder	52	Sign Frame with Two Magnetic Stem Bases	34
Clear 3-Sided Signholder	42	Frame Mount	24	Sign Frame with Wall Mount	37
Clear Adjustable Signholder	49	Frameless Signholder	15	Sign Frame with Wire Bin Mount	35
Clear Angle Baseholder	41	Front Loading Aluminum Snap Frame	16	Sign Riser	45
Clear Card Holder with Base	51	Gift Card Hanger	19	Single Stem Shovel Base	26
Clear Centre Mount Signholder	51	Gondola Center Flat Base	26	Slatwall Mount	23
Clear Countertop Adjustable Signholder	51	Gondola Center Stem Base	26	Small Base Clip	51
Clear Extruded Hinged Signholder	48	Gondola Upright Metal Telescopic Bracket	46	Small Double-Sided Hanging Boards	43
Clear Extruded Signholder	40	Greeting Card Divider	40	Small Flip Number Set	43
Clear Extruded Wire Basket Card Clip	48	Imperial Frames	14	Small Single-Sided Hanging Boards	43
Clear Extruded Wire Basket Signholder	48	Large Base Clip	51	Snap-It Signholder	40
Clear Grip Signholder	50	Large Double-Sided Hanging Boards	43	Spring Coil Mount with Griper Applied	31
Clear Inverted T-Signholder	39	Large Flip Number Set	43	Spring Coil with Card Clip	31
Clear L-Angled Signholder	39	Large Single-Sided Hanging Boards	43	Spring Coil with Extrusion Adapter	31
Clear L-Shaped Signholder	42	Magnetic Base-Cross	27	Standing Bulletin Sign with Flat Base	32
Clear Plastic Pin with Large Card Holder	52	Magnetic Clip-On Signholder	54	Standing Bulletin Sign with Trumpet Base	33
Clear Plastic Pin with Memo Clip	52	Magnetic Stem Base	27	Stem	20
Clear Price Ticket Cube	50	Male-Male Stem, 90°	22	Stem Connector	20
Clear Sign Frame Adapter	46	Memo Clip with Magnetic Base	50	Stem Mount	20
Clear Sign Frame Gripper	46	Metal Self-Centering Mount	28	Stem Mount Reducer	22
Clear Signholder	41	Metal Signholder	38	Strip Mount Card Holder	25
Clear Signholder with Metal Base	38	Metal Signholder with Shovel Base	38	Suction Cup Clip-On Signholder	54
Clear Slatwall Foldover Signholder	39	Metal Threaded Stem	38	Suction Cup Locking Sign Clip	29
Clear Spring Coil	31	Metal Threaded Swege Stem	38	Suction Cup Mount	27
Clear T-Base Holder	41	Metric Frames	14	SuperGrip® Flag C-Channel Card Holder	48
Clear Tent-Shaped Signholder	39	Parallel Magnetic Base	27	SuperGrip® Header Signholder	46
Clear Top Mount Signholder	39	Peg Hook Signholder	22	Telescopic Pole Mount	20
Clear Tri-Card Signholders	40	Pegboard / Slatwall Extension Mount	21	The Wobbler	19
Clear T-Shaped Signholder	42	Pegboard / Slatwall Mount	22	Threaded Stem Adapter	20
Clear Vinyl C-Channel Sign Holders	15	Pegboard Metal Telescopic Bracket	46	Tube-Clip Mount	23
Clear Vinyl Foldover Sign Holders	15	Pegboard Sign Clip	29	Under-Shelf Mount Signholder	30
Clear Vinyl Pocket Signholders	15	Pegboard/Slatwall Mounting Kit	45	Under-Shelf Mount SuperGrip® Signholder	30
Clear Y-Shaped Signholder	42	Perforated Shelf Card Clip	47	Universal Hang-Rod Clamp	25
Clip-In Data Strip Fold N Hold	49	Pivoting Sign Clip	47	Universal Mount	25
Clip-On 2" Signholder	53	Pivoting Stem Connector	22	Wall Mount Clip	27
Clip-On Adhesive Adapter	53	Price Spear	52	Wide UPC / Label Holder	52
Clip-On Adhesive Adapter for Wire	53	Reusable Magic Frame	16	Wire / Bin Mount	23
Clip-On Extended Sign Protector	54	Saddle Clip Mount	23	Wire / Peg Card Clip	47
Clip-On Extended Signholder	54	Self-Centering C-Channel Mount	28	Wire Fence Clip	24
Clip-On Extended Spring Signholder	54	Self-Centering Mount on Expandable Bracket	24	Wobbler Floor Standing Signholder	33
Clip-On Sign Protector	54	Self-Centering Pegboard / Slatwall Mount	24		
Clip-On Signholder	53	Self-Centering Under Shelf Swivel Mount	28		

BROCHURE HOLDERS

2 Tier Slant Back Brochure Holder	59
2 Tier Wall Mounted Brochure Holder	59
3 Tier Double Wall-Mounted Business Card Holder	60
3 Tier Slant Back Brochure Holder	58
4 Pocket Brochure Holder	59
4 Tier Double Brochure Holder	58
4 Tier Double Business Card Holder	60
4 Tier Slant Back Brochure Holder	58
4 Tier Traditional Brochure Holder	58
Ballot Box	62
Card Holder	60
CD / Brochure Holder	57

CD / Brochure Holder with Feet	57
Counter Top Book Easel	62
Euro-Style Green Edge Brochure Holder	59
Extended Pocket Brochure Holder	57
Magazine Pocket Holder	57
Plate Holder	62
Single Business Card Holder	58
Slant Back Brochure Holder	59
Slant Back Wall-Mounted Brochure Holder	58
Slatwall / Pegboard Shelf	61
Slatwall Adjustable Shoe Shelf with Toe Stop	61
Slatwall Magazine Holder	61

Slatwall Magazine Holder with Spring Front	61
Slatwall Magazine Pocket	61
Slatwall Shoe Shelf	61
Slatwall Utility Shelf	61
Traditional Double Brochure Holder	59
Traditional Wall-Mounted Brochure Holder	60
U-Shaped Risers	62
Wall-Mounted Brochure Holder (Wide)	60

SHELF TICKETING STRIPS

1" Straw Clip	67
2" High Self-Adhesive Data Strip and Label Holder	64
3" Label Holder with D-Tape	67
3" High Self-Adhesive Data Strip and Label Holder	64
4" Flip Channel	65
5"x 3" Flip-Up Label Holder For Shelf Ticket Mouldings	67
Angled Card Holder with D-Tape	64
Basket Clip	69
Bulk Bin Hinge	67
C-Channel Label Holder	64
C-Channel Label Holder with Adhesive	64
Clear Dual Extrusion	66
Clear Peghook Label Holder	70
Clear Wire Bin Holder	70
Clear Wire Shelf Ticket Channel	66
Double Label Holder	71
Dual Frame	72

Extrusion Label Holder	70
Flip Label Holder	65
Glass / Wood Label Holder	70
Glass / Wood Label Holder - 45° Angle	71
Glass / Wood Label Holder - 90° Angle	70
Glass Mount Shelf Label Holder	67
Glass Shelf Extrusion - 90° Angle	67
Glass Shelf Flip-Up Label Holder	70
Gondola Top Card Clip	67
Hinged Basket Clip	69
Hinged Basket Clip Gripper	65
Hinged Extrusion	66
Hinged Label Holder	68
Label Holder with D-Tape	64
Large Hinged Extrusion	66
Pole Gripper	72
Shelf Label Holder	65

Shovel Base Holder	71
Signholder Extrusion	65
Slatwall Card Holder	68
SuperGrip® 1" Flush Signholder	69
SuperGrip® 60° Panel Former	71
SuperGrip® Signholder	69
SuperGrip® Wire Flush Signholder	70
SuperGrip® Wire Signholder	69
Tube Holder	72
Universal Label Holder	72
Warehouse Aisle Innovator	68
Wire / Basket Shelf Label Holder	66
Wire Bin Label Holder	68
Wire Channel Clip	65
Wire Clip Holder	71

MODULAR MERCHANDISING SYSTEMS

2" Snap-In Adjustable Divider	76
2" Snap-In Adjustable Divider with Front Stops	76
2" Snap-In Divider	76
2" Snap-In Divider with Front Stops	76
4" Snap-In Adjustable Divider	77
4" Snap-In Adjustable Divider with Front Stops	77
4" Snap-In Divider	77
4" Snap-In Divider with Front Stops	77
Adapter Clips	103
Adjustable Clip-In Divider	77
Adjustable Crossbar	94
Adjustable Tray Style Pusher Kit	89
Chocolate Bar Pusher Kit	89
Clear Front Fence	81, 101
Condiment System	100
Cosmetic Tray	80
Cosmetic Tray Divider	80
Custom Gravity Wedge	103

Deli / Cheese Pusher Kit - 14" Deep	88
Deodorant Pusher Kit - 16" Deep	87
Drink System	100
DVD / Video Game Pusher Kit	88
DVD / Video Games Pusher Box	85
Extra Wide Paddle	83, 92, 103
Extruded CD / DVD / Video Game Pusher	85
Extruded Divider	102
Extruded End Cap	102
Extruded Gravity Feed / Pusher System	98
Flip Data Strip	97
Fold N Load Front T-Snap	81
Fold N Load™ 14" Deep Light Duty Pusher Kit for Pharmacy Products	87
Freezer Pusher Kit - 22" Deep	89
Greeting Card Divider	78
Gum Pusher Kit	89
Heavy Duty Divider	76
Heavy Duty Extruded Track	102

Heavy Duty Extruded Track and Divider	101
Heavy Duty Paddle	83, 103
Heavy Duty Pusher - 3" Wide	75
Hook Bar C-Clamp with Label Plate	95
Insert Shelf	84
Interlocking Pusher Tray	79
Kwickload™ COOLER BAFFLE	95
Kwickload™ Crossbar Mount Kit	93
Kwickload™ Pivoting Label Holder	92
KWICKLOAD™ PUSHER SYSTEM	90
Kwickload™ Shelf Mount Plate Kit	93
Label Holder Snap Bar	81
Large Clear Divider with T-Shaped Base	78
Large Clear Front	82
Large Divider	78
Large Interlocking Pusher Tray	79
Light Duty Extruded Track and Divider	101

INDEX

MODULAR MERCHANDISING SYSTEMS

Light Duty Fold N Load™ - 7/8" Wide	74
Light Duty Paddle	83, 102
Light Duty Pusher - 7/8" Wide	75, 86
Loop Hook Snap-On Pusher	84
Medium Duty Extruded Track and Divider	101
Medium Duty Paddle	83, 92, 102
Medium Duty Paddle with Ridges	83, 103
Medium Duty Pusher - 2" Wide	75
Metal Deli Meat Shelf	95
Moulded Dividers	94
Multi-Use Heavy Duty Pusher	75
Multi-Use Medium Duty Pusher	75
Paper Plate Pusher Kit	89
Pegboard / Slatwall Clear U-Hook	80
Pegboard Mount Light Duty Pusher System	97
Pharmacy Pusher Kit - 14" Deep	87
Produce Pusher Kit - 16" Deep	88
Pull Out Adjustable Crossbar Mount Light Duty Pusher System	97

Pusher Bottle Front	101
Pusher Clear Front	92
Pusher Curved Front	82, 92
Pusher Finger Fronts	82
Rear T-Snap - Punched	81
SHELF COOLER BAFFLE / SUPPORT BAR	95
Shelf Management Mat	86
Shelf Management Mat Dividers	86
Shelf Mount Pusher with Adjustable Dividers	79
Shelf Mounted Bottle Pusher Kit - 16" Deep	88
Shelf Mounted Light Duty Pusher System	97
Slatwall / Pegboard and Wire Shelf Frame Holder	84
Small Clear Divider with T-Shaped Base	78
Small Divider	78
Snap Bar and Label Holder	81
Snap-In Adjustable T-Divider	78
Spice System	100

Standard Interlocking Tray	79
Support Bar	94
Tall Light Duty Paddle Straight	83,102
Tall Light Duty Paddle with Angled Front	83
Thin Adjustable Clip-In Divider	77
T-Snap with Foam Tape	81, 96
Upright Mount Light Duty Pusher System	97
Versa Pusher Clip	85
Wire / Flat Fence Clear U-Hook	86
Wire Dividers	94
Wire Shelf Snap-On Pusher	85

SECURITY / LOSS PREVENTION

Fort Knox™ Security Box	112
Fort Knox™ Security Box with Active Alarm	112
Fort Knox™ Security Hang Tab	112
Invisi-Sheild™ Hardware Kit	111

Invisi-Sheild™ Panel Kit	111
Invisi-Shield™ Standard Kit with Pushers 16" Deep	107, 111
Lock Box	108
Pull-Out Shelf Pusher Kit with Slide Mechanism	107

Secure Merchandiser Shelf	110
Secure Merchandiser Slide Shelf with Invisi-Shield™	107
Security Flip Door	109
Shelf Pusher Kit	107

HANGING RETAILERS & DISPLAY COMPONENTS

3-Way Wire Carousel	137
4-Way Wire Carousel	137
Adhesive Display Strip	120
Adhesive Piece Roll	122
Adhesive Roll	122
Arrow Fastener	123
Arrowhead Thumbsnap	135
Bases	138
Basic Easy-Peel Hang Tab	130
Belly Button Push Pin	135
Black Product Stop	129
Ceiling Grip Clip	132
Ceiling Loop	132
Ceiling Twist Clip	132
Channel Mount Spring Wobbler	121
Christmas Tree Push Pin	135
Clear Bowl with Stem	136
Clear Edge Protector	123
Clip-In Data Strip Fold N Hold	126
Corrugate Display Butterfly Hook	127
Display Caster	126
Display Foot	126
Display Hook	128
Display Pole - Corrugate	121
Display Pole - Metal	138
Display Pole Signholder	125
Double C-Hook	133
Double Duty Loop Hook	128
Double Round Hook	129

Double Round Hook with Tab	128
Double Sided Hanging Retailer Extender	118
Double-Sided Strip Retailer (12 Clip)	120
Double-Sided Strip Retailer (with Optional Header)	119
Durable Vinyl Pouch Strip Retailer	120
Easy Carry Handle	131
Easy-Peel Hang Tab	130
Elastic Cord with Barbs	133
Flexible Hang Tab	130
Flexible Hang Tab - Wide	130
Flexible Hinge	124
Flexible Magnets	121
Foam Block Stand-Off	122
Fold-Up Hang Tab	130
Gift Card Extender	115
Hang Tab	131
Hang Tab - Cylinder	131
Hang Tab Sheet	131
Hang Tab Sheet - Wide	131
Hanging Wand Retailer	119
Heavy Duty Moulded Strip Retailers	118
Hook & Loop Fastener Button Roll	122
Hook & Loop Fastener Roll	122
Hook Hang Tab	130
Inventory Control Clip	129
Large Easy Peel Hang Tab	130
Large Handle Strap	131
Light Duty Strip Retailer (12 Clip)	118
Locking Strip Retailer (with Header)	119

Metal Grid Clip	133
Mini Triarama Mobile Kit	132
Mobile Spring	133
Permanent Locking Straps	122
Plastic Support Clamp	137
Plastic Turntable	125
Revolving Clip Strip Display	138
Ribbed Round Hook	129
Rotating Ceiling Hook	132
Scanner Hook	129
Screw and Wing Nut Set	135
Shelf Support — 2 Piece	124
Shelf Support — 4 Sided	124
Shelf Support — Horizontal	123
Shelf Support — Single	123
Shelf Support — Vertical	123
Sign Clip Adaptor	137
Signholder Pegboard Bracket	126
Small Handle Strap	131
Spider Clip	125
Split Ring	121
Spring Wobbler	121
Standard Strip Retailer	119
Strip Retailer Mounting Hooks	120
Suction Cup with # 8-32 Stud and Nut	134
Suction Cup with Check Hook	134
Suction Cup with Metal U-Hook	134

HANGING RETAILERS & DISPLAY COMPONENTS

Suction Cup with Mushroom Head	134
Suction Cup with Plated Metal Clamp	134
Suction Cup with Thumbtack	134
SuperGrip 2-Way Clip	124
SuperGrip H-Clip	124
SuperGrip® Signholder for Display Poles	126
SuperGrip® Signholder Pole Gripper	125
The Extended MAX Hanger	115
The Max	114
The MAX Bottle Holder - Clear	116
The MAX Bracket for Warehouse Uprights	117
The MAX Butterfly Hook	116
The MAX Card Holder - Clear	116

The MAX Bracket for Warehouse Uprights	117
The MAX Butterfly Hook	116
The MAX Card Holder - Clear	116
The MAX Counter Spinner	117
The MAX Extension Bracket	115
The MAX FloorSpinner	117
The MAX Hanger	115
The MAX Hook	116
The MAX Pegboard / Slatwall Bracket	117
The MAX Pocket with Versa Pusher Clip	116
The MAX Spinner Bracket	117
The MAX Universal Bracket	117
Triarama Mobile Kit	132

Twist-On Clip	133
Twist-On Mini Clip	133
Two-Piece Scanner Hook	128
Universal Push Pin	135
Universal Push Pin Remover	135
Viking Screws	135
Wire and Corrugate Display Butterfly Hook	127
Wire and Corrugate Display Hook	127
Wire and Corrugate Display Hook with C-Channel	128
Wire and Corrugate Display Hook with Scan/Label Plate	127
Wire Dump Bin	138
Wire Feet	121

MERCHANDISING SOLUTIONS

3 Face Shelf Spinner	151
Ballot Box	152
Beverage Holder	145
Bowl Divider	149
Bowl Divider with Sign Holder	149
Bucket Display	143
Check Out Mat	151
Clear Plastic U-Hook	143
COOL-ADS™ - Coupon Accessory	147
COOL-ADS™ - Plastic Handle	147
COOL-ADS™ - Sound & Light Module	147
Cooler Merchandiser Rack	145
Corrugate Powerwing Clip	144
Countertop Display Bin	152
Cube Bin	143
Cup Display	143
Deskwindo™	151
Dividers	141
Dividers (for Divider Bin / Tray)	142

DVD / Video Games Pusher Box	149
Grippa™ Mushroom Head Suction Cup	141
Hexagonal Dump Bin	152
J-Track Signholder	151
Large Produce Bin	146
Magazine Pocket Holder	149
Merchandiser Rack	145
Merchandising Bowl	149
Mercury Banner Hanger	151
Metal Basket	150
Metal Tray	150
Metal U-Hook	144
Multi-Functional Divider Bin	142
Multi-Functional Divider Tray	142
Multi-Functional Tray	142, 149
Multi-Functional Tray Divider	142
Multi-Purpose Adjustable Bin	141, 150
Pegboard / Slatwall Adapter	144
Pegboard / Slatwall Clear U-Hook	141

Power Bar	144
Rectangular Bin	152
Satin Aluminum Hinge Framed Slatwall	148
Satin Aluminum Post with Grey Base	148
Satin Aluminum Signholder with Swivel Mount	149
Shelf Extender	145
Skid Fender	150
Slatwall / Pegboard Powerwing Clip	144
Slatwall / Pegboard Frame Holder	150
Slatwall Upperwing Clip	144
Small Produce Bin	146
Snap Banner Track	151
Square Bin	152
Square Window Bin	152
Warehouse Powerwing Clip	144
Wire / Flat Fence Clear U-Hook	141

BEVERAGE SYSTEMS

3 Level Lid Holder	157
3 Silo Cup/Lid Holder with Stir Stick Caddy	157
501 Whole Bean Free Flow Coffee Bin	154
700 Series Whole Bean Free Flow Coffee Bins	154
Clip-On Hot Beverage Sleeve Holder	158
Coffee Bin holder	154
Condiment Tower	155
Condiment Tray with Stir Stick Caddy	156
Cutlery Tower	158

Cutlery Tower	158
Double Gravity Pot Stand	155
Espresso Knock Boxes	158
Hot Beverage Sleeve Holder	158
Hot Beverage Sleeve Pusher	158
Pastry Case	158
Second Tier Condiment Tray Add-On	156
Short Single Gravity Pot Stand	155
Single Gravity Pot Stand	155

Single Tier Condiment Tray	156
Sloped Cup / Lid Holder	157
Stir Stick/Straw Holder Add-On	157
Syrup Racks	158
Thermal Gravity Pot Beverage Dispenser®	155
Two Tier Condiment Tray	156

LIGHTING SOLUTIONS

12" Power Feed	161
60 Watt LED Plugin Driver	162
Coloured LED Ribbon	162
Indoor Colour Changing LED Tape	162
Indoor LED Pencil Light	161
LED Indoor Strip Tape	161

Low Voltage Wire Harness	160
Low-Voltage Vertical Power Strip	160
Male / Female LED Connector	160
Outdoor High Output LED Tape	161
Outdoor LED Tape	161
Power Strip Connector Harness	160

Power Supply	161
Super Slim LED Pencil Light	160
Trio Edge Shelf Light	162
Universal LED Lit Cornice	162
Universal Undershef Light (compression fit)	162
Wire Splice Extension Kit	161

INNOVATING for the FUTURE



Your
Source for **Effective**
Display and Merchandising

www.displaypeople.com

T 001 905 738 0888

F 001 905 738 1334

sales@displaypeople.com

50 Planchet Road, Concord
Ontario, Canada L4K 2C7