

The **Grundfos CMBE** stainless steel variable speed constant pressure booster pumps are designed for pumping clean water from a cold water storage tank.

Typical applications include:

- Boosting to pressurised hot and cold water systems in domestic and light commercial premises.
- Irrigation systems with above ground storage tank.
- Water transfer to high level tanks with ball valve.

The **Grundfos CMBE** range replaces the CHIE ranges of horizontal multistage end suction pumps. CMBE models provide a compact, professional and reliable solution for pressure boosting and transfer applications. CMBE pumps are supplied complete with pressure transducer, pressure vessel and non return valve.

CMBE booster pumps are factory commissioned and require only to be connected to an electrical supply and a cold water storage tank.



OPERATION

The **Grundfos CMBE** variable speed pump maintains a constant discharge pressure within the flow range of the pump. The discharge pressure is measured by a pressure transducer; the 4-20mA pressure signal is fed to the controller within the motor. The PI controller controls the motor speed in order to maintain a constant discharge pressure. A no flow condition is determined by monitoring the discharge pressure for a drop in pressure. At regular intervals the motor speed is slightly reduced, a no flow condition is indicated if the discharge pressure remains steady. When a no flow condition has been established the pump increases the pressure by 5% of the set pressure before stopping. The pressure vessel maintains pressure on the system while the pump is stopped. When the pressure drops to 5% below the set pressure the pump is started again.

CMBE booster pumps are soft started and stopped, where the motor speed is ramped up and down. This feature eliminates water hammer normally associated with traditional pressure switch controlled pumps.

The R100 hand held infra red commissioning tool is an optional item for use with all Grundfos 'E' products, including the **CMBE boosters** to access additional features. The R100 can be used with the CMBE to lock the pump buttons to prevent unauthorized adjustments.

PUMP PERFORMANCE

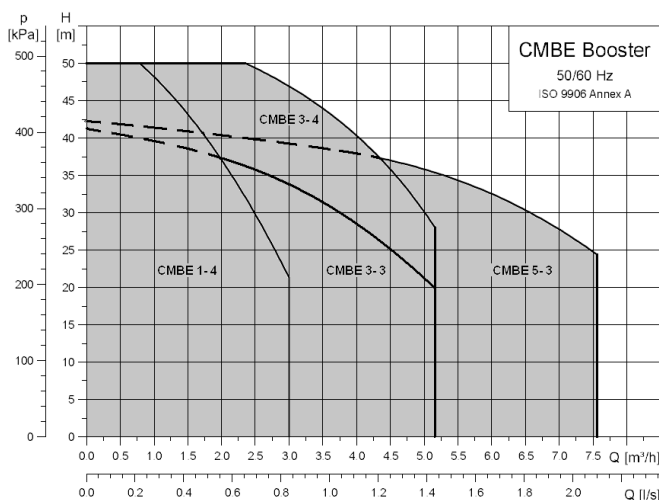

FEATURES

- Variable speed constant pressure operations
- Soft start & stop - eliminates water hammer
- Compact pump unit
- Stainless steel
- Built-in motor protection
- Low noise
- Alarm contact
- WRAS Approved pumps
- Fitted with 1.50m of supply cable - no plug

DIMENSIONS (mm) & WEIGHTS

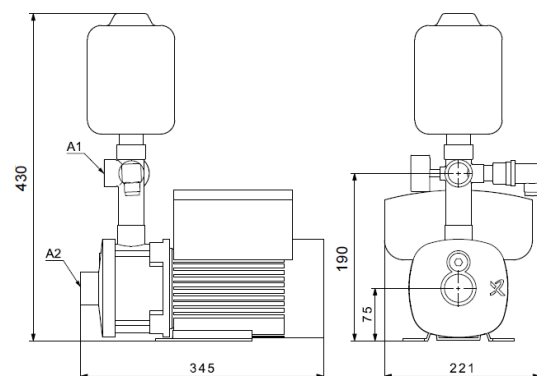

RANGE	CMBE 1-4	CMBE 3-3	CMBE 3-4	CMBE 5-3
A1	1" BSPF	1" BSPF	1" BSPF	1" BSPF
A2	1" BSPF	1" BSPF	1" BSPF	1¼" BSPF
Kg	16.4	18.5	18.8	18.5

PUMPED LIQUIDS

Potable water, rain water or other clean, thin, non-aggressive liquids not containing solid particles or fibres.

APPLICATIONS

The CMBE must be used in conjunction with a cold water storage tank in accordance with the Water Byelaws Regulations. The storage tank can be mounted on the same level as the pump, or if required remotely above the pump.

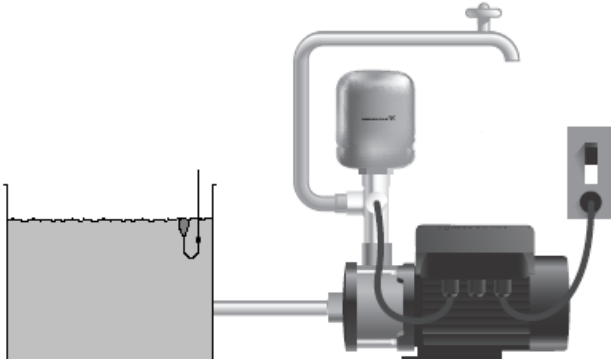

INSTALLATION

1. The pump with controls should be sited in a dry, well ventilated but frost-free position where it will not be subjected to extremes of temperature.
2. The pump should be installed on a solid surface to adequately support its weight, and to help reduce noise and vibration.
3. The environment should be non-aggressive and the atmosphere non-explosive.
4. Attention should be given to the possibility of water leakage from the unit during commissioning or service activities, in order to prevent possible damage to the surrounding area.

It is not recommended to fit the CMBE in a loft or attic space.

Minimal maintenance of the pump is required. Periodically check the 8 litre pressure vessel pre-charge pressure.

CONSTRUCTION

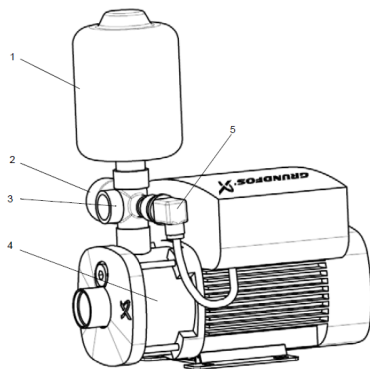

Pos.	Component
1	GT tank
2	Pressure gauge 0-6 bar
3	Five way fitting with integrated non-return valve
4	CME pump
5	Pressure sensor, type MBS 1900

CHIE REPLACEMENT

CHIE PUMP MODEL	CMBE REPLACEMENT	CHIE Pump Model	CMBE REPLACEMENT
2-30	CMBE 3-3	4-10	CMBE 5-3
2-50	CMBE 3-3	4-30	CMBE 5-3
2-60	CMBE 3-4	4-40	CMBE 5-3
		4-60	-

For CHIE pump replacement, an adaptor plate is available to raise the CM horizontal inlet to the same height as the CHIE.

TECHNICAL DATA

Mains voltage:	1 x 220-240 V, 50/60 Hz
Voltage tolerances:	-10%/+10%
Casing pressure:	10 bar max
Liquid temperature:	0°C to +60°C
Ambient air temperature:	0°C to +55°C
Sound pressure level:	53 to 57 dB(A)

ELECTRICAL DATA CM

240V 1ph 50Hz

PUMP MODEL	PRODUCT CODE	FULL LOAD CURRENT (A)	MOTOR SHAFT POWER P2 (W)
CMBE 1-4	97755482	3.6	550
CMBE 3-3	97755484	6.8	1100
CMBE 3-4	97755486	6.8	1100
CMBE 5-3	97755488	6.8	1100

FLOAT SWITCH

The low level float switch is wired into terminals 2 & 3 in the motor terminal box. Remove the factory fitted white wire link between terminals 2 and 3, using the anchor tool provided. A closed contact is required on terminals 2 and 3 for a healthy condition for the pump to run.

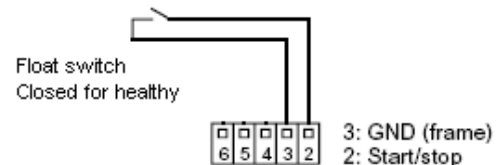
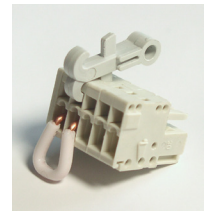

ACCESSORIES

Float level switch:	GBPS0099
Adaptor plate CHIE 2/4 to CMBE 1/3/5	96960788
R100 infra red commissioning tool:	96615297

R100



GB/CMBEBOOSTER/1111