

HIGH VOLTAGE DIFFERENTIAL PROBES

DP04 SERIES



FEATURES

The DP04 series probes offer new and innovative technologies that allow a significant increase in performance over conventional HV differential probes. This and other proprietary technologies improve the performance of our probes by a factor of ten times compared to others when used with high, common mode slew rate input signals. These probes offer accuracy along with very low offset voltage. A specially designed instrumentation power supply has been used to increase the stability and minimize noise levels. The LVC models offer higher accuracy due to use of low voltage and temperature coefficient internal components. All probes have a 50 Ω output impedance for properly driving very long length coaxial cables. This makes it ideal for off-limit test areas which are outside of the main laboratory.

HIGHLIGHTS & FEATURES

- Low Input Capacitance
- 120 MHz Bandwidth
- Up To 8 kV RMS, 12 kV Peak
- Four Standard and Four Precision Models with up to 0.1% DC Accuracy
- Unmatched Performance when Measuring High CM Slew Rate Signals
- Digital Offset Adjustment
- Low Noise

APPLICATIONS

Our probes excel in power conversion system testing. Their low input capacitance reduces circuit loading at high frequencies. The DP04 series has a high resonant input frequency, greater than 150MHz, making them prime candidates for applications requiring good accuracy at high frequencies. A proprietary input stage prevents undesirable HF oscillations that are often found in other probes when making extremely high slew rate measurements. DP04 probes can be used in automotive industry, especially for R&D on electrical and hybrid vehicles. Other applications include megawatt traction inverters, power supply design, power generation, UPS's, electro-magnetic systems, high energy research, fusion research and surge testing. The DP04 can be mounted inside systems allowing users to replace lower performance voltage measuring modules. Other possible uses are for close monitoring of in-system power switching devices for failure prevention in ultra-reliable equipment. Custom versions are available on request.

GENERAL SPECIFICATIONS AND CHARACTERISTICS

INPUT	DP04-100	DP04-100-LVC	DP04-1K	DP04-1K-LVC	DP04-2K	DP04-2K-LVC	DP04-10K	DP04-10K-LVC
Input Voltage CM RMS Max ¹	1.0 kV		4.0 kV	3.15 kV	4.0 kV	3.15 kV	4.0 kV	3.15 kV
Input Voltage CM Peak Max	175 V		1.75 kV		3.5 kV		6.0 kV	
Input Voltage CM Peak Max ¹				6.0 kV				
Input Voltage DM RMS Max ¹	2.0 kV		8.0 kV	6.3 kV	8.0 kV	6.3 kV	8.0 kV	6.3 kV
Input Voltage DM Peak	175 V		1.75 kV		4.0 kV		12 kV	
Input Voltage DM Peak Max ¹				12.0 kV				
Bandwidth				120 MHz				
Division Ratio	1:100		1:1,000		1:2,000		1:10,000	
Input impedance	1 MΩ 2.2 pF each input to GND		10 MΩ 2.2 pF each input to GND					
OUTPUT								
Output Voltage DC, RMS	±1.75 V							
Output Voltage Peak	±2.00 V							
Output Impedance	50 Ω (50 Ω termination is required)							
Risetime	<2.9 ns							
Offset	±580 μV digitally adjustable (~36 μV/step) using the up (+) and down (-) momentary offset switches							
Accuracy	1.0%	0.1%	1.0%	0.1%	1.0%	0.1%	1.0%	0.1%
Noise	10 μVrms							
Common Mode Rejection								
100Hz	-120 dB	-130 dB	-145 dB	-155 dB	-145 dB	-155 dB	-145 dB	-155 dB
100KHz	-100 dB	-110 dB	-115 dB	-125 dB	-115 dB	-125 dB	-115 dB	-125 dB
10MHz	-90 dB	-100 dB	-100 dB	-110 dB	-100 dB	-110 dB	-100 dB	-110 dB
MECHANICAL								
Case Cover	Aluminum (Aluminium)							
Dimensions (L x W x D)	5.125" X 3.125" X 1.675" (130 mm X 79 mm X 43 mm)							
Unit Weight	1.27 lb (575g)							
Cooling System	Convection							
Input Leads	4 mm safety plugs							
Output Terminal	50Ω RG223 BNC-BNC							
Power	±5.20 V @ 100 mA							
ENVIRONMENT								
Operating Temperature	-40° C to +85° C							
Storage Temperature	-55° C to +100° C							

Notes

- 1) At 25°C ambient temperature horizontal mounting orientation.
- 2) All parameters are typical specified at 25°C ambient temperature unless otherwise indicated.
- 3) Information and specifications contained within this publication may change without notice.
- 4) Non-Measurable. Peak voltages can be applied for <5 s.
- 5) CM stands for Common Mode and DM for Differential Mode.

MECHANICAL DRAWINGS

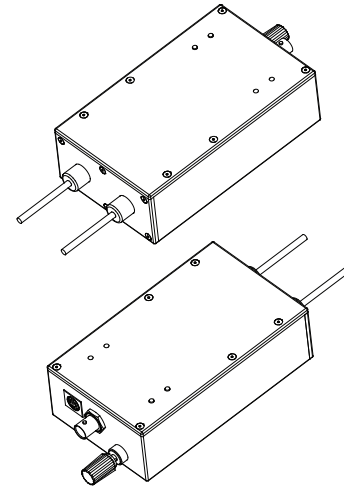
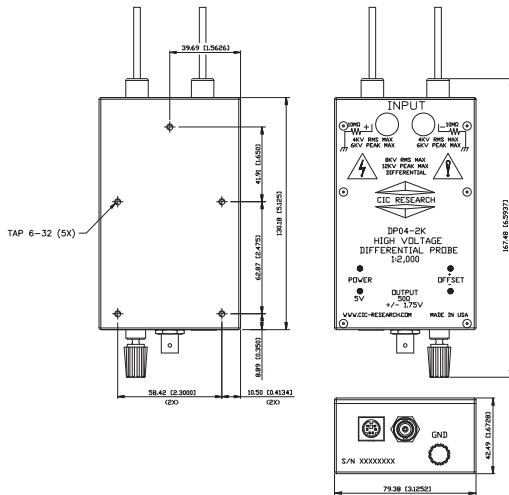

SYSTEM MOUNTING

Direct Mounting

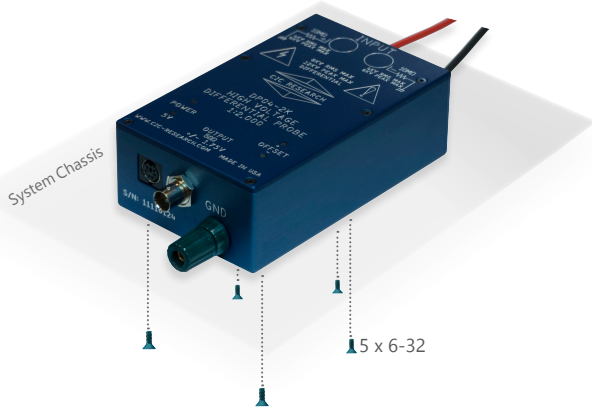

DP04 series probes can be mounted directly on a base plate or enclosure walls with 5 x 6-32 screws. Optional mounting flange models are available, shown below. These can be mounted with 4 x 10-32 (or M5) screws.

Mounting Flange Type A

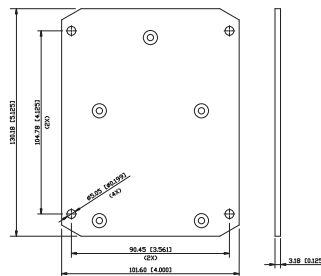

Mounting Flange Type B

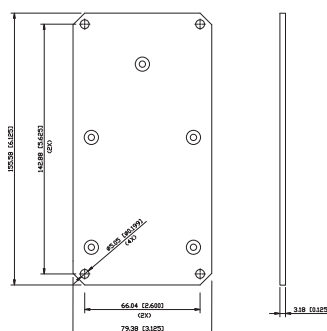

Note: Units are - mm [in]