



M9 / M9D

M11 / M11D

-001 thru -019

Self-Contained Steam Sterilizer

Serial Number Prefixes:

M9 [CZ, DA, DB, DX, DY, FK, LA, FL, OM]

M9D [FF, FG]

M 11 [ES, ET, FP, FR, GB, NP]

M11D [GC, GD]



M9/D
M11/D

-001 thru -019

FOR USE BY MIDMARK TRAINED TECHNICIANS ONLY

TABLE OF CONTENTS

Section/Paragraph	Page	Section/Paragraph	Page
IMPORTANT INSTRUCTIONS			
General Safety Instructions.....	iii	4.18 Heating Element and Gasket Removal / Installation	4-15
Safety Alert Symbols	iii	4.19 Filter Removal / Installation	4-16
Warranty Instructions	iii	4.20 Door Gaskets Removal / Installation	4-17
SECTION I GENERAL INFORMATION			
1.1 Model / Serial Number Location.....	1-1	4.21 Display PC Board Removal / Installation ...	4-17
1.2 Specifications	1-1	4.22 Condensing Tank Assembly Removal / Installation	4-18
1.3 Description of Normal Operation	1-2	4.23 Pressure Relief Valve Removal / Installation	4-19
1.4 Ordering Parts	1-3	4.24 Pressure / Temperature Potentiometers Adjustments	4-20
1.5 Special Tools	1-4	4.25 Display PC Board Lamp / Display / Button Check	4-23
SECTION II TESTING AND TROUBLESHOOTING			
2.1 Operational Test.....	2-1	4.26 Pressure Relief Valve Check.....	4-24
2.2 Troubleshooting Procedures	2-1	4.27 Dry Cycle Dip Switches Adjustment	4-25
SECTION III SCHEDULED MAINTENANCE			
3.1 Scheduled Maintenance	3-1	4.28 M9 / M11 Door Opening Test	4-26
SECTION IV MAINTENANCE/SERVICE INSTRUCTIONS			
4.1 Safety Precautions.....	4-1	SECTION V SCHEMATICS AND DIAGRAMS	
4.2 Top Cover Removal / Installation	4-1	5.1 Wiring Diagrams	5-1
4.3 Right Hand Side Panel Removal / Installation	4-1	5.2 Flow Diagram	5-11
4.4 Left Hand Side Panel Removal / Installation	4-2	5.3 Pressure / Temperature Chart	5-12
4.5 Back Panel Removal/Installation	4-3	SECTION VI PARTS LIST	
4.6 Base Inspection Cover Removal / Installation	4-3	6.1 Description of Bullets	6-1
4.7 Bellows Assembly Removal / Installation	4-4	6.2 Torque Specifications and Important Assembly Notes	6-1
4.8 Condensing Tank Water Level Sensor Removal / Installation	4-5	NOTE: <i>The Parts List in this manual is divided into two sections [M9 / M9D & M11/M11D]. Verify model and refer to appropriate section.</i>	
4.9 Temperature Sensor Assembly Removal / Installation	4-6	M9 / M9D Parts List	
4.10 Pressure Vessel Water Level Sensor Removal / Installation	4-6	M9 Component / Page Cross-Reference	6-2
4.11 Vent Solenoid Removal / Installation	4-7	M9D Component / Page Cross-Reference	6-3
4.12 Fill Solenoid Removal / Installation	4-9	Main Enclosure Components	6-4*
4.13 Control PC Board Removal / Installation ...	4-10	Plumbing and Sensor Components	6-5*
4.14 Door Switch Removal / Installation	4-13	Pressure Vessel Components	6-6*
4.15 Pulse Solenoid Removal / Installation	4-13	M9 Manifold Components	6-7*
4.16 Thermostat Removal / Installation	4-14	M9D Manifold Components	6-8*
4.17 Wire Tray Rack and Tray Plate Removal / Installation	4-15	Electrical Components	6-9*
		M9 / M9D Control PC Board	6-10
		M9 Labels and Decals	6-11
		M9D Labels and Decals	6-12
		Printer Components	6-13
		Racks, Trays, and Cleaner	6-14*
		Packaging	6-15

(*) Indicates that there has been a serial number break for the illustration and that there are additional point page(s) following the original page.

TABLE OF CONTENTS

Section/Paragraph **Page**

SECTION VI PARTS LIST - continued

NOTE: *The Parts List in this manual is divided into two sections [M9 / M9D & M11/M11D]. Verify model and refer to appropriate section.*

M11 / M11D Parts List

M11 Component / Page	
Cross-Reference	6-17
M11D Component / Page	
Cross-Reference	6-18
Main Enclosure Components	6-19*
Plumbing and Sensor Components	6-20*
Pressure Vessel Components	6-21*
M11 Manifold Components	6-22*
M11D Manifold Components	6-23*
Electrical Components	6-24*
M11 / M11D Control PC Board	6-25
M11 Labels and Decals	6-26
M11D Labels and Decals	6-27
Printer Components	6-28
Racks, Trays, and Cleaner	6-29*
Packaging	6-30

COMMENTS	7-1
FAX ORDERING FORM	7-2

IMPORTANT INSTRUCTIONS

General Safety Instructions

Safety First: The primary concern of Midmark Corporation is that this sterilizer is maintained with the safety of the patient and staff in mind. To assure that services and repairs are completed safely and correctly, proceed as follows:

- (1) Read this entire manual before performing any services or repairs on this sterilizer.
- (2) Be sure you understand the instructions contained in this manual before attempting to service or repair this sterilizer.

Safety Alert Symbols

Throughout this manual are safety alert symbols that call attention to particular procedures. These items are used as follows:



DANGER

A DANGER is used for an imminently hazardous operating procedure, practice, or condition which, if not correctly followed, will result in loss of life or serious personal injury.



WARNING

A WARNING is used for a potentially hazardous operating procedure, practice, or condition which, if not correctly followed, could result in loss of life or serious personal injury.



CAUTION

A CAUTION is used for a potentially hazardous operating procedure, practice, or condition which, if not correctly followed, could result in minor or moderate injury. It may also be used to alert against unsafe practices.



EQUIPMENT ALERT

An EQUIPMENT ALERT is used for an imminently or potentially hazardous operating procedure, practice, or condition which, if not correctly followed, will or could result in serious, moderate, or minor damage to unit.

NOTE

A NOTE is used to amplify an operating procedure, practice or condition.

Warranty Instructions

Refer to the Midmark "Limited Warranty" printed in the Installation and Operation Manual for warranty information. Failure to follow the guidelines listed below will void the warranty and/or render the M9 sterilizer unsafe for operation.

- In the event of a malfunction, do not attempt to operate the sterilizer until necessary repairs have been made.
- Do not attempt to disassemble sterilizer, replace malfunctioning or damaged components, or perform adjustments unless you are one of Midmark's authorized service technicians.
- Do not substitute parts of another manufacturer when replacing inoperative or damaged components. Use only Midmark replacement parts.

**SECTION I
GENERAL INFORMATION**

1.1 Model / Serial Number Location

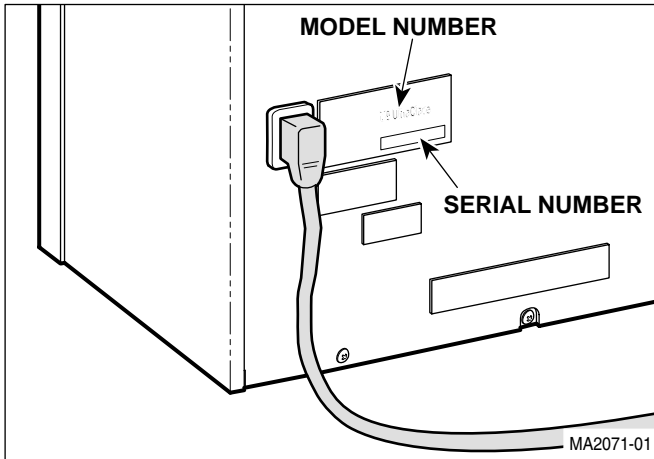

Figure 1-1. Model / Serial Number Location

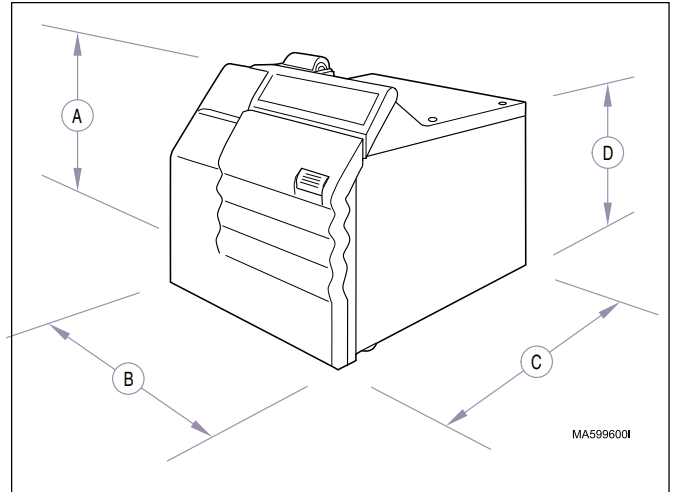

Figure 1-2. Dimensions

1.2 Specifications

Table 1-1. Specifications

Description	Data
M9 / M9D Dimensions:	
Front Height (A, Figure 1-2)	16.4 in (41.8 cm) <i>(printer adds approx. 0.5 in)</i>
Width (B)	15 in (38.1 cm)
Depth (C)	18.1 in (47.8 cm)
Back Height (D)	13.75 in (34.9 cm)
Chamber Diameter	9 in. (22.8 cm)
Chamber Depth	15 in. (38.1 cm)
Shipping Carton	22 in x 17.75 in x 18 in (56 cm x 45 cm x 46 cm)
Weight:	
Reservoir Empty	70 lb (32 kg)
Reservoir Full	77 lb (35 kg)
With Shipping Carton	78 lb (36 kg)
Water Reservoir Capacity	Approx. 7/8 gallon (3.31 Liters to full mark)

Description	Data
M11 / M11D Dimensions:	
Front Height (A, Figure 1-2)	17.7 in (44.9 cm) <i>(printer adds approx. 0.5 in)</i>
Width (B)	17.6 in (44.8 cm)
Depth (C)	22.4 in (56.8 cm)
Back Height (D)	15.25 in (38.7 cm)
Chamber Diameter	11 in. (27.9 cm)
Chamber Depth	18 in. (45.7 cm)
Shipping Carton	23 in x 27.5 in x 21.5 in (58.4 cm x 69.8 cm x 54.6 cm)
Weight:	
Reservoir Empty	96 lb (43.5 kg)
Reservoir Full	106 lb (48 kg)
With Shipping Carton	128 lb (58 kg)
Water Reservoir Capacity	Approx. 1.25 gallon (4.7 Liters) to full mark

SECTION I GENERAL INFORMATION

NOTE

The following information applies to all models of the M9 / M9D / M11 / M11D included in this manual.

Table 1-1. Specifications - *continued*

Description	Data
M9 / M9D / M11 / M11D	
Electrical Requirements:	
100 VAC Unit	100 VAC 50 - 60 HZ, 15 amp, single phase
115 VAC Unit	110 - 120 VAC 50 - 60 HZ, 15 amp, single phase
230 VAC Unit	220 - 240 VAC 50 - 60 HZ, 7 amp, single phase
Power Consumption:	
100 VAC Unit	1425 WATTS, 15 amps @ 100 VAC
115 VAC Unit	1425 WATTS, 12 amps @ 120 VAC
230 VAC Unit	1500 WATTS, 7 amps @ 240 VAC
Recommended Circuit:	
A separate (dedicated) circuit is recommended for this sterilizer. The sterilizer <i>should not</i> be connected to an electrical circuit with other appliances or equipment unless the circuit is rated for the additional load.	
Chamber Pressure:	
Operating	27 - 31 psi (186 - 215 kPa)
Minimum Before Door Is Released (M9 & M11 only)	0.7 psi (5 kPa)
Maximum Before Safety Valve Opens (older units)	35 psi (241 kPa)
Maximum Before Safety Valve Opens (newer units)	40 psi (275.7 kPa)
Chamber Temperature (Operating):	
Unwrapped Cycle	272-273 °F (133-134 °C)
Pouches Cycle	272-273 °F (133-134 °C)
Liquids Cycle	252-253 °F (122-123 °C)
Packs Cycle	252-253 °F (122-123 °C)
Maximum Before Thermostat Energizes	295 °F (146 °C)

1.3 Description of Normal Operation

(Figure 1-3 shows Display Panel Buttons & Lamps)

(Figure 1-4 shows location of Major Components)

Plug Power Cord Into Outlet

Display: E001 (Error lamp flashes)

1. Line voltage (100/115/230V) is supplied to Control PC Board.

NOTE

There are two primary fuses on PC Board. Faulty fuse(s) will disable all functions of sterilizer.

Press ON/STANDBY Button

Display: (Error lamp goes out; ON/STANDBY lamp illuminates, & program lamps flash)

Select Cycle (Unwrapped, Pouches, Liquids, Packs)

Display: TIME/TEMP. (for the selected cycle)

Press START Button

NOTE

After the START button is pressed, the PC board continuously monitors the Door Switch for continuity. If continuity is not detected, the PC board stops the cycle, and the Door Ajar lamp illuminates.

1. The Fill Cycle is initiated.

Fill Cycle

Display: (Filling lamp illuminates)

1. Line voltage from PC Board energizes Fill Solenoid; this allows water to flow into Pressure Vessel.
2. Water fills Pressure Vessel until it makes contact with the Pressure Vessel Water Level Sensor.
3. When water completes the ground circuit between the Pressure Vessel Water Level Sensor & the chassis, the PC Board de-energizes the Fill Solenoid & the Sterilization Cycle is initiated.

Sterilization Cycle

Display: (Sterilizing lamp illuminates)

xxx° (chamber temperature)

xx PSI [after temperature reaches 208°F (98°C)]

NOTE

During the Sterilization Cycle, the Temperature Probe monitors the chamber temperature and the PC Board monitors chamber pressure.

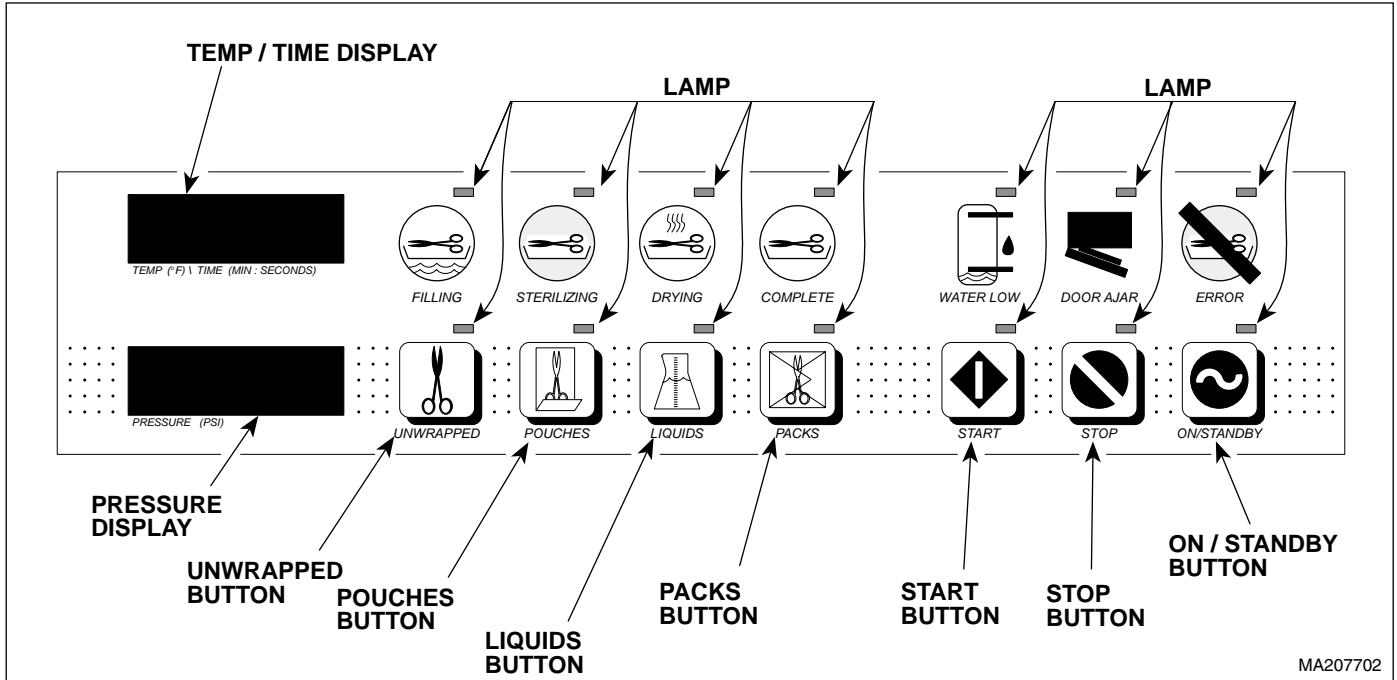

Figure 1-3. Display Panel Button / Lamp Locations

MA207702

Sterilization Cycle - continued

1. Line voltage from PC Board energizes Heating Element.
2. Air & steam flow thru Bellows as water in chamber begins to boil. When temperature reaches approx. 215° F (101° C), the Bellows closes and pressure begins to build.
3. When chamber reaches required temperature, Heating Element is de-energized and sterilization time begins to count down on Display PC Board.
4. Line voltage from PC Board energizes Heating Element intermittantly to maintain required temperature & pressure until time elapses.
5. When sterilization time expires, the Heating Element de-energized & the Vent Cycle is initiated.

Vent Cycle

1. Line voltage from PC Board energizes Vent Solenoid.
[Liquids Cycle requires chamber to cool to 223° F (106° C) before Vent Solenoid is energized]
2. Chamber pressure is released thru Vent Solenoid until pressure drops to 0.7 psi (4.8 kPa).

3. Control PC Board sounds 5 beeps.
4. M9 / M11: Line voltage from PC Board energizes Pulse Solenoid. Door opens automatically. Drying Cycle is initiated.
M9D / M11D: "Open the Door" Lamp illuminates. "dddd" appears on Display PC Board. Manually open door at this time. Drying Cycle is initiated.

Drying Cycle

Display: (Drying lamp illuminates)
xx:xx (time counts down from 30 minutes)
(Complete lamp illuminates at end of cycle)

1. Line voltage energizes Heating Element for 45 seconds. (30 minute countdown begins on Display PC Board).
2. Heating Element is energized intermittantly (as shown below) until Dry Cycle is complete.

45 seconds ON - 2 minutes OFF
30 seconds ON - 2 minutes OFF
xx* seconds ON - 2 minutes OFF (until cycle ends)

**This time is adjustable. Refer to adjustment procedure in Section IV if necessary.*

SECTION I GENERAL INFORMATION

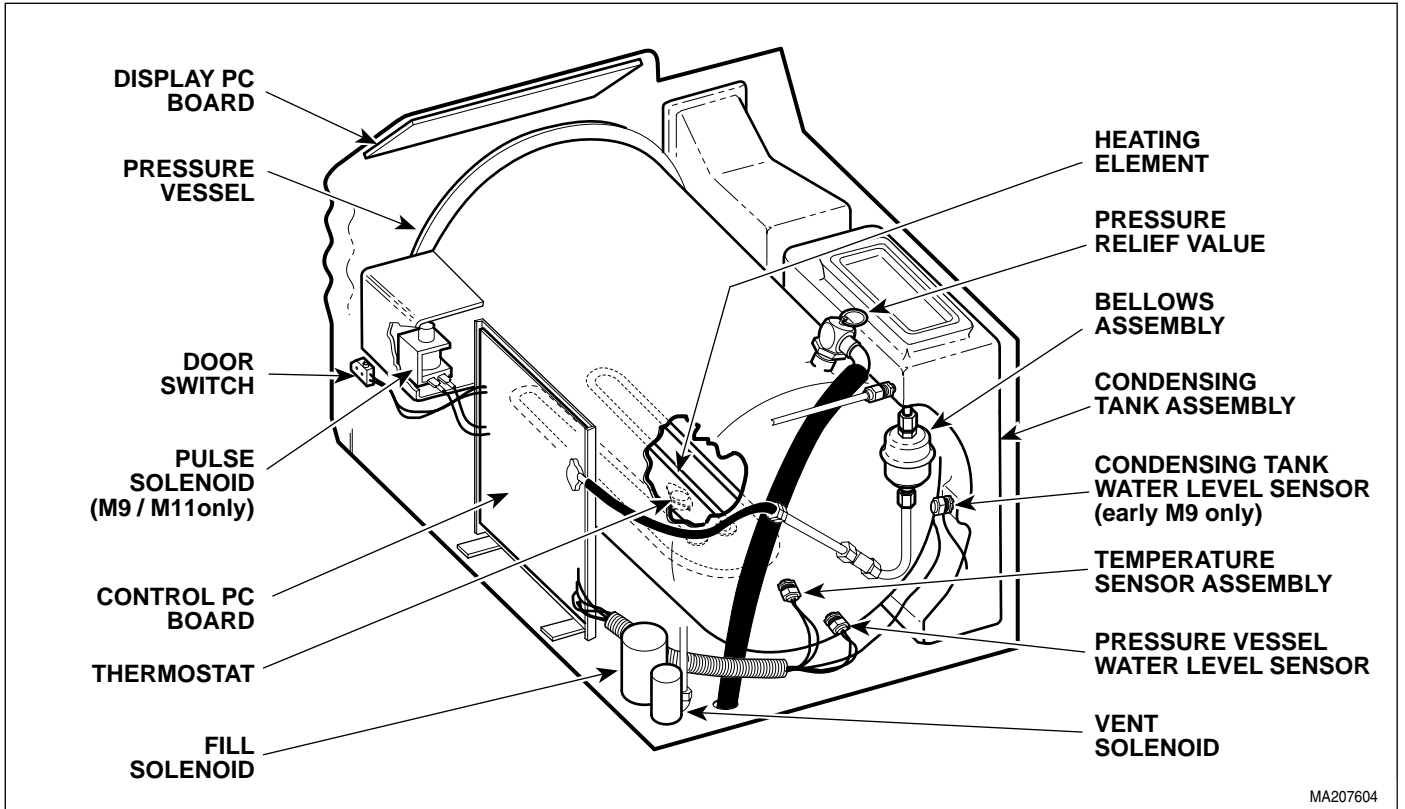

Figure 1-4. Major Components

MA207604

1.4 Ordering Parts

Contact Midmark's Technical Service Department with all necessary information (model / serial number, part number, etc.).

Orders can be placed using the Fax Order Form (page 7-2) or by calling the phone number on the back cover of this manual.

1.5 Special Tools

Special tools needed to repair the sterilizer are listed below in Table 1-2.

Table 1-2. Special Tool List

Description of Special Tool	Manufacturer's Name / Address / Phone	Manufacturer's Part Number	Purpose of Special Tool
Digital Multimeter (must be capable of displaying 3 digits)	Commercially Available	Any Type	Used to check probes, switches, and connections for proper function by performing continuity checks.
Water Level Sensor Wrench	Midmark Corp. 60 Vista Drive Versailles, Ohio 45380 (513) 526-3662	050-2324-00	Used to hold fitting in place so the nut that holds water level sensor can be loosened / tightened.
3/32 in. Diameter Punch	Commercially Available	Any Type	Used to remove / install two roll pins which secure door switch in place or roll pin which secures latch lever to pulse solenoid.
Pressure Gauge Test Harness	Midmark Corp. 60 Vista Drive Versailles, Ohio 45380 (513) 526-3662	002-0372-00	Used to check the pressure in the pressure vessel during a cycle to diagnose malfunctions and / or adjust the pressure range potentiometer to a correct setting.

SECTION II
TESTING AND TROUBLESHOOTING

2.1 Operational Test

To effectively diagnose a malfunction of the sterilizer, perform the Pressure / Temperature Potentiometers Adjustment procedure. Refer to para 4.24.

2.2 Troubleshooting Procedures

If a malfunction is detected, locate the **Problem & Symptom** in Table 2-1. Perform the **Check** for each **Probable Cause** indicated. Follow instructions in the **Correction** column as they apply.

Table 2-1. Troubleshooting Guide

Problem	Symptom	Probable Cause	Check	Correction
Error code 1 (Power interruption to control PC board).	Shuts down during Sterilization cycle.	Overheat thermostat activated. (Pressure leak)	Check for pressure leaks. Refer to Table 2-2.	Replace malfunctioning component at pressure leak.
		Overheat thermostat activated. (Not filling properly)	Check that Filling lamp illuminates. Be sure water level sensor is dry.	Replace water level sensor if necessary. Refer to para 4.10.
			Check that sterilizer is level.	Adjust sterilizer to level.
		Bad electrical connection(s).	Check sterilizer and facility for proper electrical connections.	Tighten / replace loose connections.
		Faulty overheat thermostat. (stuck open)	Perform continuity check on thermostat (N.C.).	Replace thermostat. Refer to para 4.16.
	Shuts down during Drying cycle.	Overheat thermostat activated. (High input voltage)	Check facility input voltage. Voltage should not exceed Electrical Requirements as noted in para 1.2.	Adjust the dry cycle time dip switches. Refer to para 4.27.
			Check resistance of heating element. Refer to para 5.1 for normal resistance ranges.	If resistance is out of limits, replace heating element. Refer to para 4.18.
		Faulty overheat thermostat. (stuck open)	Perform continuity check on thermostat (N.C.).	Replace thermostat. Refer to para 4.16.
Error code 2 (Stop Button pressed during cycle)	Shuts down during cycle.	Stop Button pressed during cycle.	—	Restart cycle after beeper signal stops.
Error code 3 (ON / Standby Button pressed during cycle)	Shuts down during cycle	On / Standby Button pressed during cycle.	—	Restart cycle after beeper signal stops.
Error code 4 (Door Ajar)	Shuts down during cycle	Door latch not closed.	Check if door latch is engaging switch.	Adjust door latch. Clean/lubricate door latch and pins.
		Door switch connection loose.	Check door switch connection.	Tighten / replace loose connections.
		Door switch malfunctioning.	Perform continuity check on door switch (N.O.).	Replace door switch. Refer to para 4.14.

SECTION II TESTING AND TROUBLESHOOTING

Table 2-1. Troubleshooting Guide - *continued*

Problem	Symptom	Probable Cause	Check	Correction
Error code 5 [Display pressure exceeded 35 psi (241 kPa)]	Shuts down during Sterilization cycle	Sterilizer overloaded.	Check that pressure vessel is not overloaded with heavy linen packs.	Instruct operator to reduce load size.
		Bellows malfunctioning. (closing early)	Bellows should close at approx. 212° F (100° C).	Replace bellows. Refer to para 4.7.
		Sterilizer potentiometers out of calibration and/or dirty temperature sensor.	Clean temperature sensor; then check calibration of using Pressure Gauge Test Harness.	Perform Temperature / Pressure Potentiometer Adjustment. Refer to para 4.24.
		Temperature sensor malfunctioning.	Check calibration.	Replace temperature sensor assembly. Refer to para 4.9.
Error code 6 [Display temperature exceeded 277°F (136°C)]	Shuts down during Sterilization cycle	Slow pressure leak.	Check for pressure leaks. Refer to Table 2-2.	Replace malfunctioning component at pressure leak.
		Sterilizer potentiometers out of calibration and/or dirty temperature sensor.	Clean temperature sensor; then check calibration of using Pressure Gauge Test Harness.	Perform Temperature / Pressure Potentiometer Adjustment. Refer to para 4.24.
		Temperature sensor malfunctioning.	Check calibration.	Replace temperature sensor assembly. Refer to para 4.9.
Error code 7 [Display pressure dropped below 24.5 psi (169 kPa)]	Shuts down during Sterilization cycle	Slow pressure leak.	Check for pressure leaks. Refer to Table 2-2.	Replace malfunctioning component at pressure leak.
		Sterilizer potentiometers out of calibration and/or dirty temperature sensor.	Clean temperature sensor; then check calibration of using Pressure Gauge Test Harness.	Perform Temperature / Pressure Potentiometer Adjustment. Refer to para 4.24.
		Temperature sensor malfunctioning.	Check calibration.	Replace temperature sensor assembly. Refer to para 4.9.

SECTION II TESTING AND TROUBLESHOOTING

Table 2-1. Troubleshooting Guide - *continued*

Problem	Symptom	Probable Cause	Check	Correction
Error code 8 - M9 & M11 only [Door switch did not change status after door solenoid was activated.	Door opens at end of cycle.	Door switch malfunctioning.	Perform continuity check on door switch. Check for loose connections.	Replace door switch. Refer to para 4.14.
	Door does not open at end of cycle.	Latch lever & pulse solenoid plunger mechanism malfunctioning.	Perform M9/M11 Door Opening Test. Refer to para 4.28.	Remove any debris or buildup from latch lever & pulse solenoid mechanism.
		Door pins and latch bracket not functioning properly.	Check for burrs on door pins and latch bracket in door.	Remove burrs; then clean and lube with lithium based grease.
		Zero pressure potentiometer out of calibration.	Check calibration of zero pressure potentiometer.	Adjust zero pressure potentiometer. Refer to para 4.24.
		Pulse solenoid malfunctioning.	Perform M9/M11 Door Opening Test. Refer to para 4.28.	Replace pulse solenoid. Refer to para 4.15.
Error code 9 [Pressure exceeded 0.9 psi (6.2 kPa) during Dry cycle]	M9/M11 - Door opens at end of cycle. M9D/M11D - Door is manually opened at end of cycle	Zero pressure potentiometer out of calibration.	Check calibration of zero pressure potentiometer.	Adjust zero pressure potentiometer. Refer to para 4.24.
	M9/M11 - Door does not open at end of cycle.	Latch lever & pulse solenoid plunger mechanism malfunctioning.	Perform M9/M11 Door Opening Test. Refer to para 4.28.	Remove any debris or buildup from latch lever & pulse solenoid mechanism.
		Door pins and latch bracket not functioning properly.	Check for burrs on door pins and latch bracket in door.	Remove burrs; then clean and lube with lithium based grease.
		Zero pressure potentiometer out of calibration.	Check calibration of zero pressure potentiometer.	Adjust zero pressure potentiometer. Refer to para 4.24.
	Door is closed when error is detected.	Door was closed during Dry cycle.	-	Inform operator not to shut door during Dry cycle.

SECTION II TESTING AND TROUBLESHOOTING

Table 2-1. Troubleshooting Guide - *continued*

Problem	Symptom	Probable Cause	Check	Correction
Error code 10 (Watchdog timer reset error)	Sterilizer does not complete cycle.	Control PC board has had a software / hardware failure.	Disconnect power; then check for disconnected wiring in sterilizer or facility. Connect power & run additional cycle.	If error code persists, replace control PC board. Refer to para 4.13.
Error code 11 (Software interrupt error)	Sterilizer does not complete cycle.	Control PC board has a software / hardware malfunction.	Disconnect power for approx. 10 seconds; then connect power & run additional cycle.	If error code persists, replace control PC board. Refer to para 4.13.
Error code 12 (Ram test error)	Sterilizer does not complete cycle.	Control PC board has a software / hardware malfunction.	Disconnect power for approx. 10 seconds; then connect power & run additional cycle.	If error code persists, replace control PC board. Refer to para 4.13.
Error code 13 -M9D & M11D only (Door switch status unchanged since last cycle)	Sterilizer does not complete cycle.	Door switch is malfunctioning.	Perform continuity check on door switch.	Replace door switch. Refer to para 4.14.
Blown Fuses	Main fuse on PC board blown	Short in pulse solenoid.	Unplug pulse solenoid; then run M9/M11 Door Opening Test. Refer to para 4.28.	Replace pulse solenoid. Refer to para 4.15.
No Display Lights	Unit displays temp. & pressure, but does not show LED status lights.	-	-	Disconnect power for approx. 30 seconds. Then connect power and check for proper operation.
Low Water Light (comes on after approx. 5 min.)	Water continuously fills chamber.	Water level sensor dirty or malfunctioning.	Clean water level sensor; then perform continuity check.	Replace water level sensor. Refer to para 4.10.
		Temperature sensor malfunctioning.	Disconnect temp. sensor from PC board; then check for proper operation.	Replace temperature sensor. Refer to para 4.9.
	Water is not entering chamber.	Filter is dirty/clogged.	Clean filter with speedclean & brush or in ultrasonic cleaner.	Replace filter if necessary. Refer to para 4.19.
		Debris trapped in fill solenoid.	Disassemble fill solenoid and remove any debris.	Replace fill solenoid. Refer to para 4.12.
Low Water Light (comes on immediately) (Older-style units only)	Low water light illuminates as soon as cycle is started.	Condensing tank level sensor malfunctioning.	-	Unplug sensor from PC board & permanently jumper connection on board.

SECTION II TESTING AND TROUBLESHOOTING

Table 2-1. Troubleshooting Guide - *continued*

Problem	Symptom	Probable Cause	Check	Correction
<i>Sterilizer has no power.</i>	No response when ON/STANDBY is pushed (no lamps illuminate).	Sterilizer is not plugged in.	Check that power cord is plugged in to sterilizer and outlet.	Plug in power cord to sterilizer or outlet.
		Fuse blown on control PC board.	Perform continuity check on control PC board fuses.	Replace fuses.
		Thermostat activated.	Check for voltage at input to control PC board from thermostat.	Wait for sterilizer to cool. Re-check voltage. If none, replace thermostat. Refer to para 4.16.
<i>Fill cycle malfunction.</i>	Unit skips fill cycle.	Water level sensor wet from previous cycle.	-	Allow pressure vessel water level sensor to air dry or remove and hand dry. Refer to para 4.10.
	Chamber fills very slowly.	Filter / tubing plugged.	Remove filter and tubing and inspect.	Replace / clean filter and/or tubing. Refer to para 4.19.
		Pressure vessel water level sensor malfunctioning or dirty.	Unplug sensor from PC board & jumper connection on board. Check for proper operation.	Replace/clean pressure vessel water level sensor. Refer to para 4.10.
	Chamber overfills with water.	Pressure vessel water level sensor malfunctioning or dirty.	Unplug sensor from PC board & jumper connection on board. Check for proper operation.	Replace/clean pressure vessel water level sensor. Refer to para 4.10.
		Loose, broken, or dirty connection between pressure vessel water level sensor and control PC board.	Perform continuity check between connector and pressure vessel water level sensor.	Replace/clean broken wires or connections.
		Sterilizer is not level.	Check sterilizer for level installation.	Re-install sterilizer on a level surface, adjust height of individual foot levelers, or shim up sterilizer.
		Ground screw on PC board missing.	Check PC board ground screw.	Replace ground screw.
		Temperature sensor malfunctioning.	Unplug temperature sensor from PC board then check for proper operation.	Replace temperature sensor. Refer to para 4.9.
		Fill solenoid malfunctioning or stuck.	Check resistance of solenoid. Refer to Section 5.	Replace / clean fill solenoid. Refer to para 4.12.
		Control PC board malfunctioning.	Check all Probable Causes listed above.	Replace control PC board. Refer to para 4.13.

SECTION II TESTING AND TROUBLESHOOTING

Table 2-1. Troubleshooting Guide - *continued*

Problem	Symptom	Probable Cause	Check	Correction
<p>Door does not open after vent cycle. - <i>M9 / M11 only</i></p>	<p>Pulse solenoid energizes, but door does not open.</p>	Latch lever binding.	Operate latch lever by hand to check for resistance.	Clean / lubricate latch lever.
		Door latch binding.	Operate door latch by hand to check for resistance.	Clean / lubricate door latch.
		Tray rack not pushed in all the way into chamber, causing interference with door.	Check to see if tray rack is installed properly so that it does not interfere with door.	Install tray rack properly so that it does not interfere with door.
		Pressure zero potentiometer out of calibration.	-	Adjust pressure zero potentiometer. Refer to para 4.24.
<p>Chamber does not vent properly.</p>	<p>Door opens after a longer than normal venting period. - <i>M9 / M11</i></p> <p>OPEN THE DOOR lamp illuminates after longer than normal venting period. - <i>M9D / M11D</i></p>	Drain, filter, or vent tubing plugged.	Remove filter and tubing and inspect.	Clean, drain, and flush tubing. Replace/clean filter. Refer to para 4.19.
		Vent solenoid malfunctioning or stuck.	Check resistance of solenoid coil. Refer to Section 5.	Replace/clean vent solenoid. Refer to para 4.11.
<p>Temperature does not go above 215°F (101°C).</p>	Unit will not complete sterilization cycle.	Slow pressure leak.	Check for pressure leaks. Refer to Table 2-2.	Replace malfunctioning component at pressure leak.
<p>Instruments not drying.</p>	<p>Instruments are wet after drying cycle is complete.</p>	Door is not opening at end of vent portion of cycle.	See Problem: Door does not open after vent cycle.	
		Sterilizer is not level.	Check sterilizer for level installation.	Re-install sterilizer on a level surface, adjust height of individual foot levelers, or shim up sterilizer.
		Filter is plugged.	Check that no water is left in pressure vessel after venting portion of cycle.	Replace/clean filter. Refer to para 4.19.

SECTION II TESTING AND TROUBLESHOOTING

Table 2-1. Troubleshooting Guide - *continued*

Problem	Symptom	Probable Cause	Check	Correction
<i>OPEN THE DOOR lamp does not illuminate.</i> <i>- M9D / M11D only</i>	OPEN THE DOOR lamp does not illuminate at the end of sterilization cycle.	Pressure potentiometer out of adjustment	Display PC board check will show zero pressure setting. Refer to para 4.25.	Adjust pressure potentiometer. refer to para 4.24.
<i>Code "C001"</i> <i>-M9D & M11D only</i> (Low water error)	Cycle will not run.	Water level in condensing tank is too low.	Check water level in condensing tank.	Fill condensing tank with distilled water.
	Cycle will not run. Condensing tank is full.	Fill solenoid malfunctioning or stuck.	Check resistance of solenoid. Refer to Section 5.	Replace fill solenoid. Refer to para 4.12.
		Water level sensor dirty or malfunctioning.	Clean water level sensor; then perform continuity check.	Replace water level sensor. Refer to para 4.10.
	Chamber overfills with water.	Temperature sensor malfunctioning.	Disconnect temperature sensor; then check for proper operation.	Replace temperature sensor. Refer to para 4.9.
<i>Code "C002"</i> <i>-M9D & M11D only</i> (Door ajar)	Cycle will not run.	Door ajar.	-	Close door.
<i>Code "C003"</i> <i>-M9D & M11D only</i> (Dry cycle error)	Dry cycle did not start.	Door was not opened within 30 minutes after venting.	-	Rerun cycle. Open door within 30 minutes after venting.

SECTION II TESTING AND TROUBLESHOOTING

2.3 Areas To Check For Pressure Leaks (Figure 2-1)

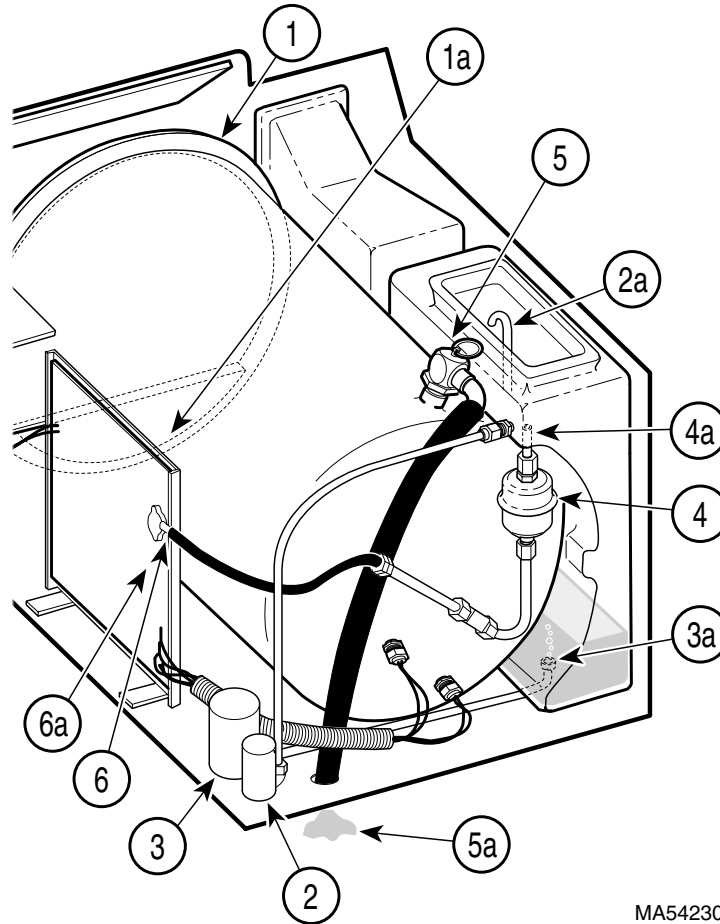

MA542300

Table 2-2. Areas To Check For Pressure Leaks

Component	Check	Correction
Door Gasket (1, Figure 2-1)	Check for water leaking around door. <i>See (1a).</i>	Replace door gasket. Refer to para 4.20.
Vent Solenoid (2)	Check for water leaking thru condensing coil. <i>See (2a).</i>	Replace vent solenoid. Refer to para 4.11.
Fill Solenoid (3)	Check for water leaking back into reservoir thru fill line, raising reservoir water level. <i>See (3a).</i>	Replace fill solenoid. Refer to para 4.12.
Bellows (4)	Check for excessive steam from bellows line in reservoir. NOTE: a light hiss of steam is not uncommon. <i>See (4a).</i>	Replace bellows. Refer to para 4.7.
Pressure Relief Valve (5)	Check for water leaking beneath back of sterilizer. NOTE: check actual pressure before replacing pressure relief valve. <i>See (5a).</i>	Replace pressure relief valve. Refer to para 4.23.
Pressure Sensor Hose (6)	Check for steam leak onto main PC board. <i>See (6a).</i>	Secure pressure sensor hose to PC board with cable tie.

**SECTION III
SCHEDULED MAINTENANCE**

3.1 Scheduled Maintenance

Table 3-1 lists inspections and services that should be performed periodically on the sterilizer.

Table 3-1. Scheduled Maintenance Chart

Interval	Inspection or Service	What to Do
Semi-annually	Obvious damage	Visually check condition of sterilizer for obvious damage such as: cracks in components, missing components, dents in components, leaks, or any other visible damage which would cause sterilizer to be unsafe to operate or would compromise the performance of the sterilizer. Repair sterilizer if necessary.
	Fasteners/hardware	Check sterilizer for missing or loose fasteners/hardware. Replace any missing hardware and tighten any loose hardware as necessary using Loctite 271 if necessary.
	Moving parts	All moving parts should be lubricated with high temperature grease.
	Warning and instructional decals	Check for missing or illegible decals. Replace decals as necessary.
	Display overlay	Check for missing, damaged, or illegible display overlay. Replace display overlay if necessary.
	Wiring connections	Check the integrity of all wiring connections. Clean all dirty connections. Tighten any loose connections. Replace any damaged connections.
	Free movement of door latch	Clean door latch. Lubricate door latch and door pins with high temperature grease.
	Free movement of door switch spring	Clean door switch spring. Lubricate door switch spring with high temperature grease. Replace door switch spring if necessary.
	Latch lever (M9 / M11 only)	Operate latch lever by hand to check for resistance. Clean latch lever. Lubricate latch lever with high temperature grease.
	Door and Dam gaskets	Remove gaskets and check for dirt on gaskets, deterioration of gaskets, or voids in gaskets. Clean gaskets using a mild soap and water solution. Replace gaskets if necessary. Refer to para 4.20.
	Filter	Clean filter using a mild soap and water solution. Replace filter if necessary. Refer to para 4.19.
	Pressure vessel water level sensor	Remove any build-up from pressure vessel water level sensors. Replace sensor if necessary. Refer to para 4.10.
	Condensing tank water level sensor (early units only)	Remove any build-up from condensing tank water level sensor. Replace sensor if necessary. Refer to para 4.8.
	Tubing	Remove tubing and inspect for buildup. Clean, drain, and flush tubing. Replace tubing if necessary.
	Display PC board	Perform the display PC board lamp/display/button check. Refer to para 4.25. Replace display PC board if necessary.
	Pressure relief valve	Perform a pressure relief valve check. Refer to para 4.26. Replace pressure relief valve if necessary. Refer to para 4.23.
Printer (optional equipment)	Check that printer prints properly. Replace ribbon cartridge if necessary. Replace printer if necessary.	
Operational test	Perform an operational test to determine if the sterilizer is operating within its specifications (Refer to para 2.1). Replace any malfunctioning components. Adjust the control PC board potentiometers if necessary. Refer to para 4.24.	

**SECTION IV
MAINTENANCE / SERVICE INSTRUCTIONS**

4.1 Safety Precautions

WARNING
Always disconnect the power cord from the outlet before removing any of the sterilizer covers/panels or making any repairs to prevent the possibility of electrical shock. Also, drain the sterilizer to prevent spills during repairs. Failure to comply with these instructions could result in serious personal injury or death.

4.2 Top Cover Removal / Installation

A. Removal

- (1) Disconnect power cord from the outlet.
- (2) If the sterilizer contains a printer, remove printer (Refer to Operation Manual).
- (3) Open sterilizer door.
- (4) Remove two screws (1, Figure 4-1) and steam block (2) from top cover (3).
- (5) Remove four screws (4) and two screws (5) from top cover (3).

- (6) On units which apply, carefully break front of top cover (3) loose from silicone sealant.

EQUIPMENT ALERT
Lift top cover carefully and slowly. Ribbon connector is still connected to display PC board and any excess pressure exerted on it could result in a damaged ribbon connector or display PC board.

- (7) Lift rear of top cover (3) and disconnect ribbon connector (6) from display PC board (7A) or control PC board (7B) (depending on whether ribbon connector (6) is part of display PC board or is a separate component).

- (8) Remove top cover (3) from sterilizer.

B. Installation

- (1) Coat mating surfaces of front panel lip and top cover (3) with silicone sealant.
- (2) Position top cover (3) over sterilizer, with rear of top cover raised, and connect ribbon connector (6) to display PC board (7A) or control PC board (7B).
- (3) Install top cover (3) on sterilizer and secure using two screws (5) and four screws (4).
- (4) Install steam block (2) on top cover (3) and secure using two screws (1).
- (5) Close sterilizer door.
- (6) If the sterilizer contains a printer, install printer (Refer to Operation Manual).

4.3 Right Hand Side Panel Removal / Installation

A. Removal

- (1) Disconnect power cord from the outlet.
- (2) Remove two screws (1, Figure 4-2) from top cover (2).

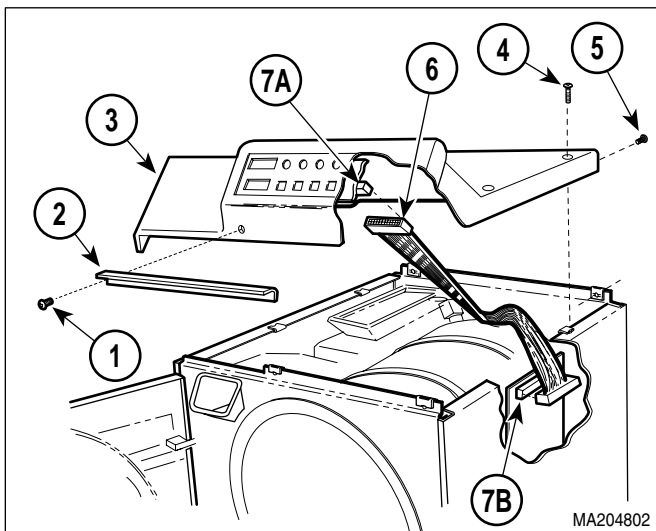

Figure 4-1. Top Cover Removal / Installation

SECTION IV MAINTENANCE / SERVICE

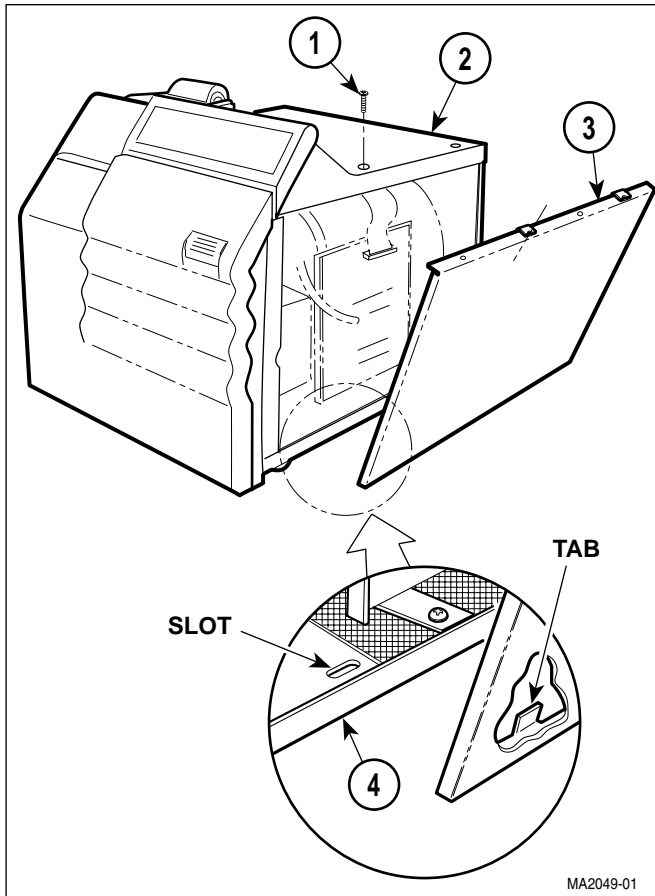

Figure 4-2. Right Hand Side Panel Removal / Installation

- (3) Pull outward and down on the top edge of the right hand side panel (3) and remove right hand side panel from sterilizer.

B. Installation

- (1) Insert two tabs of right hand side panel (3) into two slots of base (4).
- (2) Raise top edge of right hand side panel (3) into position and secure using two screws (1).

4.4 Left Hand Side Panel Removal / Installation

A. Removal

- (1) Disconnect power cord from the outlet.
- (2) Open sterilizer door.

- (3) Remove left screw (1, Figure 4-3) from steam block (2).
- (4) Remove two screws (3) from top cover (4).
- (5) Lift up the left hand corner of top cover (4), pull outward and down on the top edge of the left hand side panel (5), and remove left hand side panel from sterilizer.

B. Installation

- (1) Insert two tabs of left hand side panel (5) into two slots of base (6).
- (2) Lift up the left hand corner of top cover (4), raise the top edge of left hand side panel (5) into position, and secure using two screws (3).
- (3) Install left screw (1) on steam block (2).
- (4) Close sterilizer door.

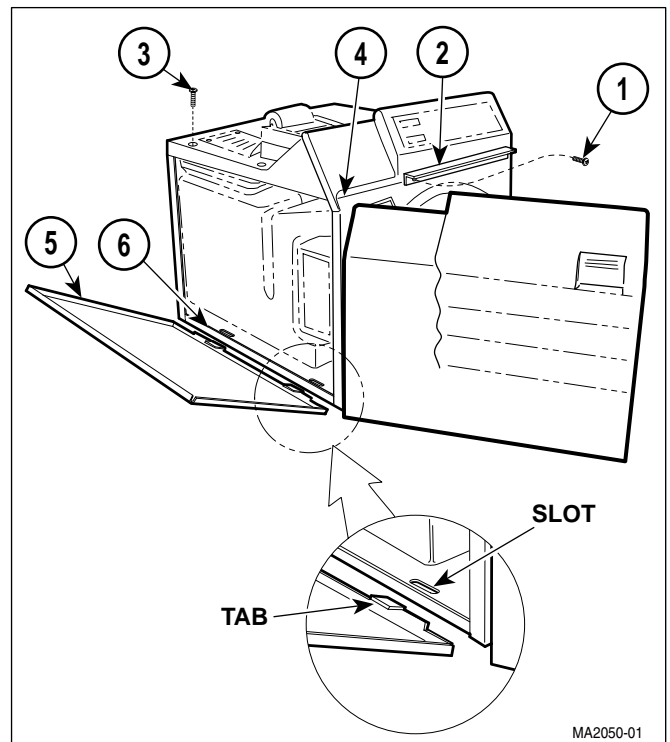

Figure 4-3. Left Hand Side Panel Removal / Installation

4.5 Back Panel Removal / Installation

A. Removal

- (1) Disconnect power cord from sterilizer.
- (2) Remove right hand side panel (Refer to para 4.3).
- (3) Remove left hand side panel (Refer to para 4.4).
- (4) Remove four screws (1, Figure 4-4) from back panel (2).
- (5) Partially remove back panel (2) by simultaneously pulling downward and outward on back panel.

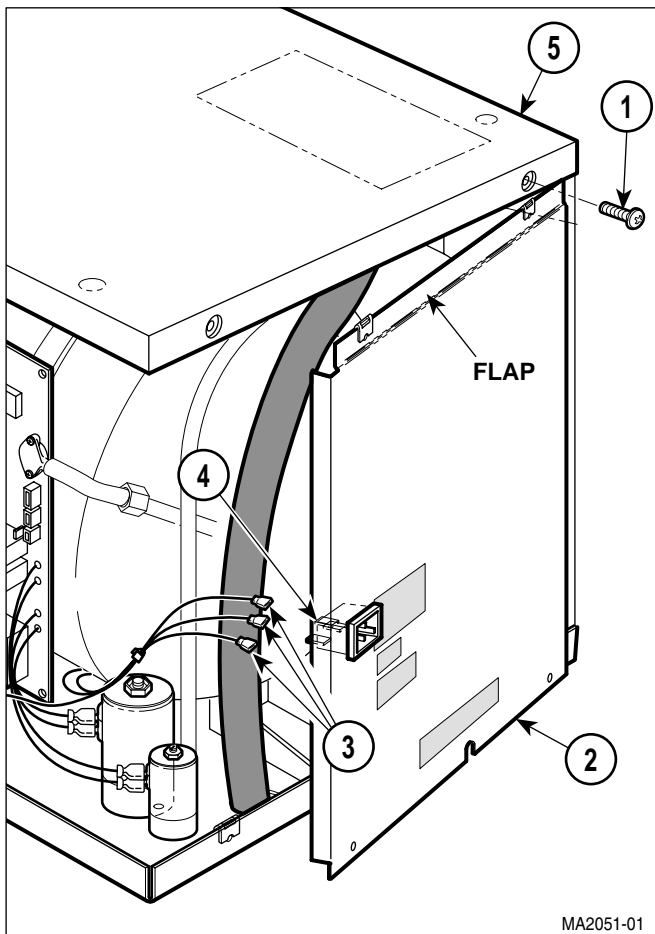

Figure 4-4. Back Panel Removal / Installation



EQUIPMENT ALERT

Ensure that wires are completely disconnected before attempting to remove back panel. Failure to do so could result in damage to sterilizer.

NOTE

Units prior to serial number CZ1110/OM1000 have a fuse holder attached to the back panel. On these sterilizers, tag and disconnect two wires from the receptacle and one wire from the fuse holder instead of performing step 6.

- (6) On older units, tag and disconnect three wires (3) from terminals of receptacle (4) and remove back panel (2) from sterilizer. On newer units, separate back panel (2) from unit as far as possible and lay it on its side.

B. Installation

NOTE

Units prior to serial number CZ1110/OM1000 have a fuse holder attached to the back panel. On these sterilizers, remove tags and connect two wires to the receptacle and one wire to the fuse holder instead of performing step 1.

- (1) On older units, remove tags and connect three wires (3) to terminals of receptacle (4).
- (2) Position flap of back panel (2) behind top cover (5) and secure back panel in place using four screws (1).
- (3) Install left hand side panel (Refer to para 4.4).
- (4) Install right hand side panel (Refer to para 4.3).

4.6 Base Inspection Cover Removal / Installation

A. Removal

- (1) Disconnect power cord from outlet.
- (2) Drain water from condensing tank.
- (3) Turn sterilizer onto its back.

SECTION IV MAINTENANCE / SERVICE

- (4) Remove two screws (1, Figure 4-5) and base inspection cover (2) from base (3).

B. Installation

- (1) Install base inspection cover (2) on base (3) and secure using two screws (1).
- (2) Turn sterilizer upright.
- (3) Refill condensing tank with distilled water.

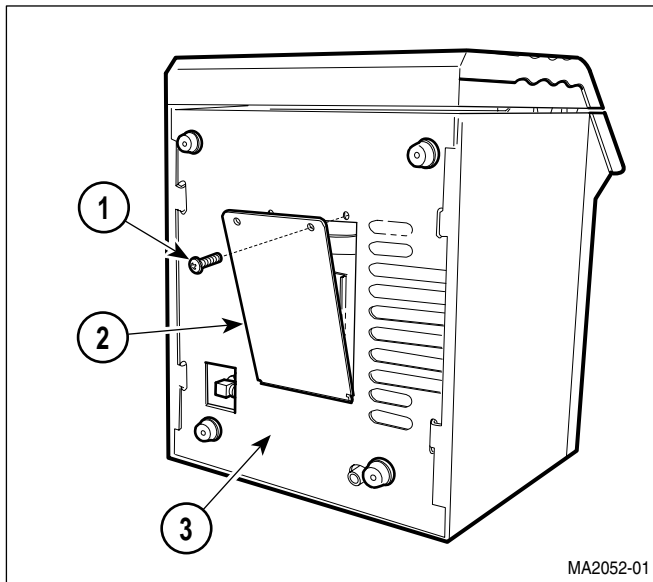

Figure 4-5. Base Inspection Cover Removal / Installation

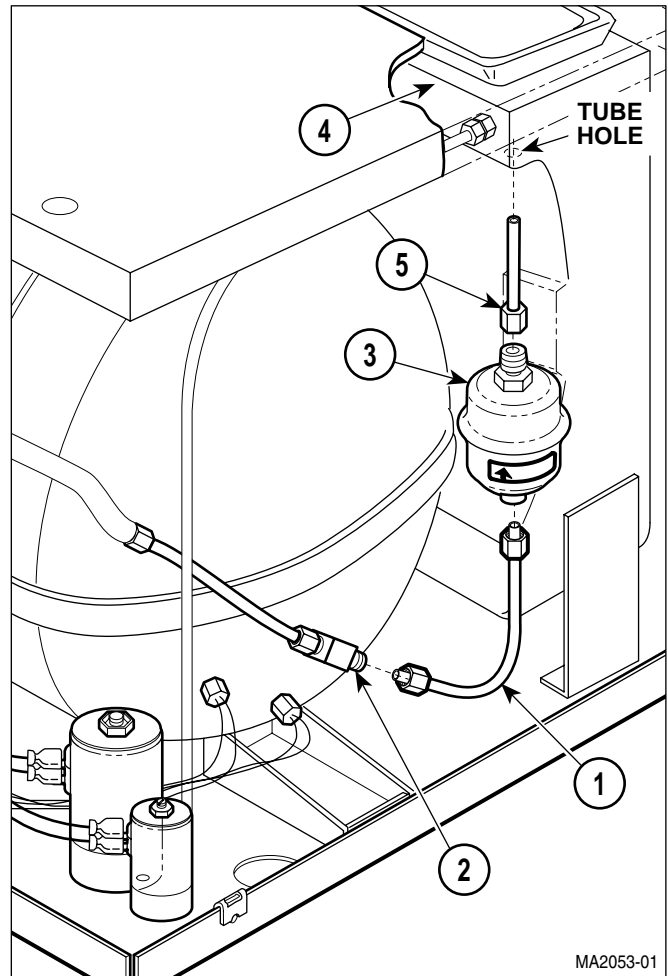

Figure 4-6. Bellows Assembly Removal / Installation

4.7 Bellows Assembly Removal / Installation

NOTE

Figure 4-6 shows old-style bellows. The procedure for the new-style is the same.

A. Removal

- (1) Remove back panel (Refer to para 4.5).
- (2) Disconnect tube (1, Figure 4-6) from tee (2).
- (3) Pull downward on bellows assembly (3) to remove bellows assembly from condensing tank (4).
- (4) Loosen and remove tubes (1 and 5) from bellows assembly (3).

B. Installation

- (1) Connect tubes (1 and 5) to bellows assembly (3).
- (2) Position bellows assembly (3) and insert tube (5) into tube hole of condensing tank (4).
- (3) Connect tube (1) to tee (2).
- (4) Install back panel (Refer to para 4.5).

4.8 Condensing Tank Water Level Sensor Removal / Installation (Applies only to Units with old style Control PC Board with EPROM Version M or Before)

NOTE

Units with old style control PC board with EPROM version N or after **or** new style control PC board do not have a condensing tank water level sensor.

A. Removal

- (1) Drain water from condensing tank.
- (2) Remove back panel (Refer to para 4.5).
- (3) Remove bellows assembly (Refer to para 4.7).
- (4) Disconnect wire (1, Figure 4-7) from terminal (2).
- (5) Using Water Level Sensor Wrench to hold fitting (3), loosen nut (4) (Refer to Table 1-2 for special tool).
- (6) Pull assembled level sensor rod (5) from fitting (3).
- (7) Remove nut (4), silicone tube (6), and crimp (7) from level sensor rod (5). Discard silicone tube and crimp.
- (8) Using vise grips to hold level sensor rod (5), remove nut (8) and terminal (2) from level sensor rod.

B. Installation

- (1) Using vise grips to hold level sensor rod (5), install terminal (2) on level sensor rod and secure using nut (8).

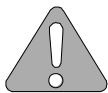

EQUIPMENT ALERT

The end of the silicone tube must extend past nut (4) after nut is installed. If it is not, the level sensor rod will not function properly because the terminal will be in contact with nut (4).

- (2) Install crimp (7), nut (4), and silicone tube (6) on level sensor rod (5) and secure by crimping crimp (7).

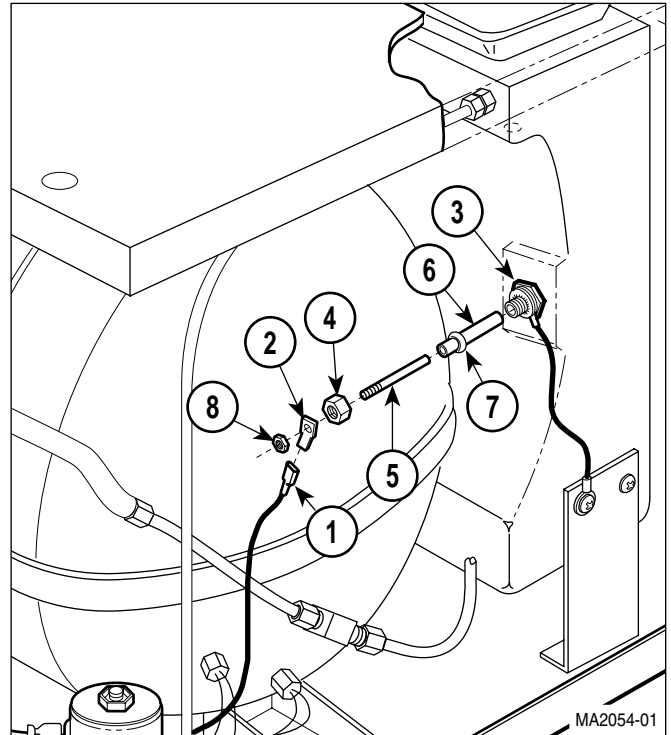

Figure 4-7. Condensing Tank Water Level Sensor Removal / Installation

- (3) Install assembled level sensor rod (5) in fitting (3).
- (4) Using Water Level Sensor Wrench to hold fitting (3), tighten nut (4) (Refer to Table 1-2 for special tool).
- (5) Connect wire (1) to terminal (2).
- (6) Install bellows assembly (Refer to para 4.7).
- (7) Install back panel (Refer to para 4.5).
- (8) Refill condensing tank with distilled water.

SECTION IV MAINTENANCE / SERVICE

4.9 Temperature Sensor Assembly Removal/Installation

A. Removal

- (1) Remove back panel (Refer to para 4.5).

NOTE

Units with old style control PC board with EPROM version N or after **or** new style control PC board will only have two wire harnesses to disconnect instead of three.

- (2) Disconnect two / three wire harnesses (1, Figure 4-8) from two / three terminals (2).
- (3) Remove flex guard tubing (3) from two / three wire harnesses (1).
- (4) Remove temperature sensor assembly (4) from pressure vessel (5).

B. Installation

- (1) Coat threads of temperature sensor assembly (4) with teflon tape.
- (2) Install temperature sensor assembly (4) in pressure vessel (5).

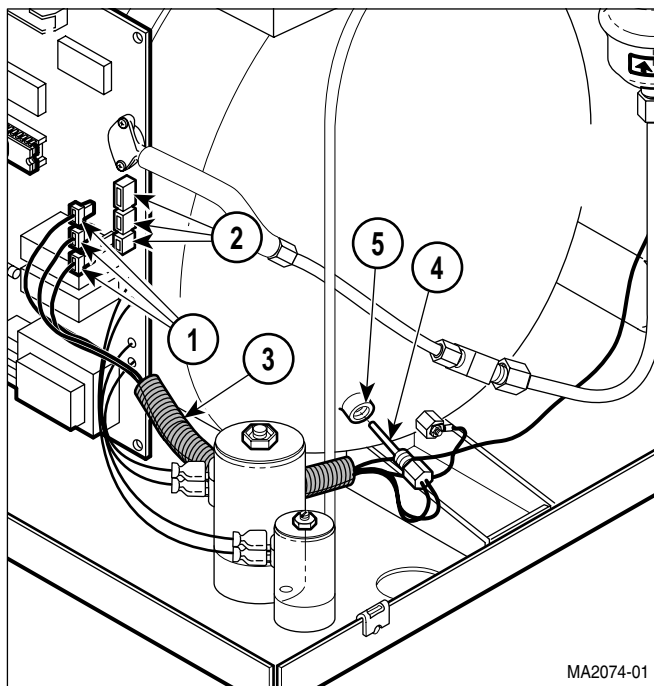

Figure 4-8. Temperature Sensor Assembly
Removal / Installation

- (3) Install flex guard tubing (3) on three wire harnesses (1).
- (4) Connect three wire harnesses (1) to three terminals (2).
- (5) Install back panel (Refer to para 4.5).

4.10 Pressure Vessel Water Level Sensor Removal/Installation

A. Removal

- (1) Remove back panel (Refer to para 4.5).
- (2) Remove wire tray rack and tray plate (Refer to para (4-17).
- (3) Disconnect wire (1, Figure 4-9) from terminal (2).
- (4) Remove nut (3) and terminal (2) from level sensor rod (4).
- (5) Remove nut (5).



EQUIPMENT ALERT

Do not try to pull level sensor rod out of back side of pressure vessel. Doing so will damage level sensor rod.

- (6) Push level sensor rod (4) thru fitting (6) and into pressure vessel (7) and remove level sensor rod.
- (7) Remove spacer (8) from level sensor rod (4).
- (8) Remove silicone tube (9) from fitting (6). Discard silicone tube (9) and crimp (10).
- (9) If damaged, remove fitting (6) from pressure vessel (7).

B. Installation

- (1) If removed, coat fitting (6) with teflon tape and install fitting in pressure vessel (7).
- (2) Install silicone tube (9) and spacer (8) on level sensor rod (4).

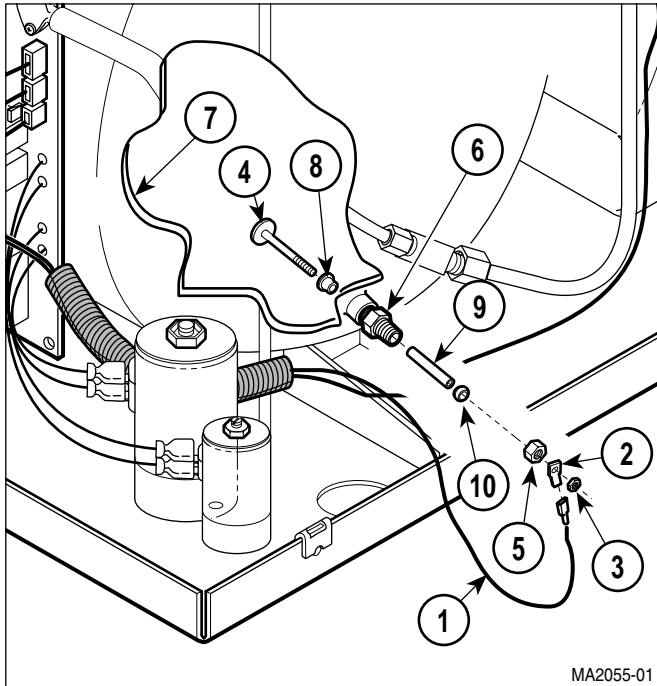

Figure 4-9. Pressure Vessel Water Level Sensor Removal / Installation

NOTE

The assembled level sensor rod must be installed from the inside of the pressure vessel.

- (3) Install assembled level sensor rod (4) in fitting (6).



EQUIPMENT ALERT

The end of the silicone tube must extend past nut (5) after nut is installed. If it is not, the level sensor rod will not function properly because the terminal will be in contact with nut (5).

- (4) Install and crimp crimp (10) on silicone tube (9).
- (5) Install nut (5).
- (6) Install terminal (2) on level sensor rod (4) and secure using nut (3).
- (7) Connect wire (1) to terminal (2).
- (8) Install wire tray rack and tray plate (Refer to para 4.17).
- (9) Install back panel (Refer to para 4.5).

4.11 Vent Solenoid Removal / Installation

NOTE

Steps will vary slightly for M9D / M11D units. Use this procedure as a guide.

A. Removal

NOTE

Units prior to serial number CZ1110/OM1000 have a manifold assembly which secures the vent solenoid. Refer to the parts list to remove the vent solenoid on these sterilizers.

- (1) Drain water from condensing tank.
- (2) Remove back panel (Refer to para 4.5).
- (3) Tag and disconnect two wires (1, Figure 4-10) from terminals (3).
- (4) Tag and disconnect two wires (2) from terminals (4).
- (5) Disconnect three tubes (5 thru 7) from elbows (8 thru 10).
- (6) Remove two screws (11) from bottom of manifold assembly (12).

NOTE

Spacer (12A) is only on newer units.

- (7) Remove manifold assembly (12) and spacer (12A) from base (13).
- (8) Hold screw (1, Figure 4-11) and loosen nut (2). Turn terminals out of the way.
- (9) Remove assembled vent solenoid (3) and elbow (4) from tee (5).
- (10) Remove elbows (4 and 6) from vent solenoid (3).

SECTION IV MAINTENANCE / SERVICE

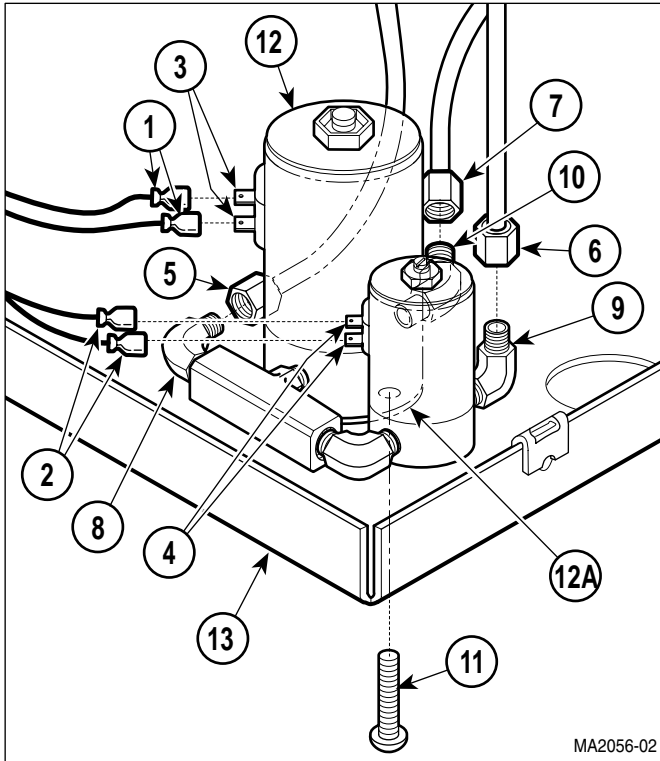

Figure 4-10. Vent Solenoid Removal / Installation

B. Installation

NOTE

The end of elbow (6) which receives a tube does not get coated with teflon tape.

- (1) Coat the threads of elbows (4 and 6, Figure 4-11) with teflon tape.
- (2) Install elbows (4 and 6) on vent solenoid (3).
- (3) Hold screw (1) and loosen nut (2). Turn terminals out of the way.
- (4) Install assembled elbow (4) and vent solenoid (3) on tee (5).
- (5) Turn terminals of vent solenoid (3) so wires will connect easily to vent solenoid.
- (6) Hold screw (1) and tighten nut (2).



EQUIPMENT ALERT

When installing the vent solenoid, the side of the solenoid marked IN needs to be connected to the pressure line. Reversing vent solenoid will cause system failure.

- (7) Install spacer (12A, Figure 4-10) and manifold assembly (12) on base (13) and secure using two screws (11).
- (8) Connect three tubes (5 thru 7) to elbows (8 thru 10).
- (9) Connect two wires (2) to terminals (4).
- (10) Connect two wires (1) to terminals (3).
- (11) Install back panel (Refer to para 4.5).
- (12) Refill condensing tank with distilled water.

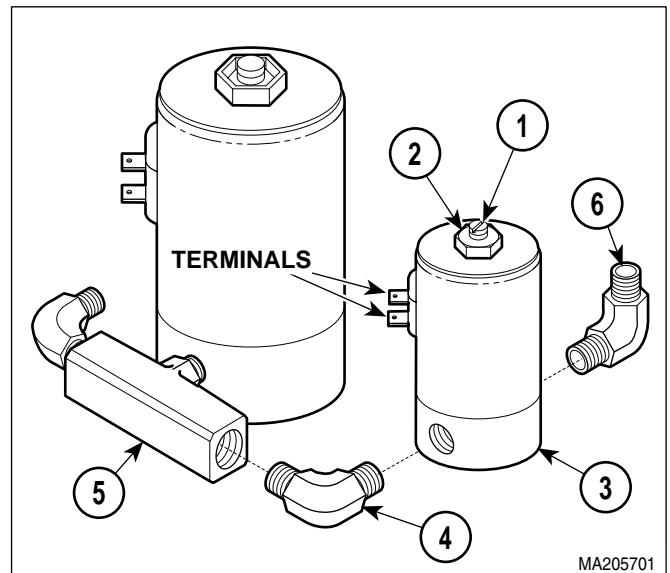

Figure 4-11. Vent Solenoid Fittings Removal / Installation

4.12 Fill Solenoid Removal / Installation

NOTE

Steps will vary slightly for M9D / M11D units. Use this procedure as a guide.

A. Removal

NOTE

Units prior to serial number CZ1110/OM1000 have a manifold assembly which secures the fill solenoid. Refer to the parts list to remove the fill solenoid on these sterilizers.

- (1) Drain water from condensing tank.
- (2) Remove back panel (Refer to para 4.5).
- (3) Tag and disconnect two wires (1, Figure 4-12) from terminals (3).
- (4) Tag and disconnect two wires (2) from terminals (4).
- (5) Disconnect three tubes (5 thru 7) from elbows (8 thru 10).
- (6) Remove two screws (11) from bottom of manifold assembly (12).

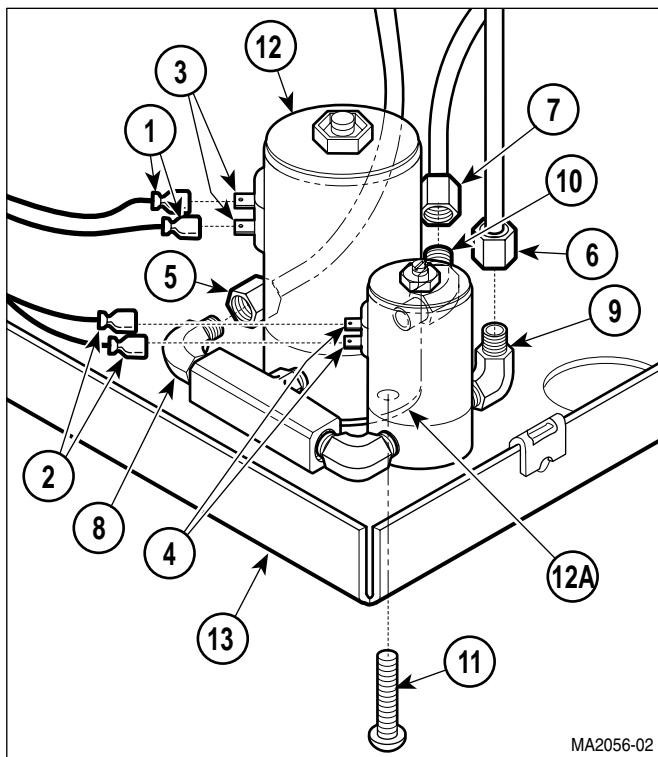

Figure 4-12. Fill Solenoid Removal / Installation

NOTE

Spacer (12A) is only on newer units.

- (7) Remove manifold assembly (12) and spacer (12A) from base (13).
- (8) Hold screw (1, Figure 4-13) and loosen nut (2). Turn terminals out of the way.
- (9) Remove assembled vent solenoid (3) and elbow (4) from tee (5).
- (10) Remove elbow (6) and tee (5) from fill solenoid (7).
- (11) Remove elbow (8) from fill solenoid (7).

B. Installation

- (1) Coat threads of tee (5, Figure 4-13) and elbows (6 and 8) with teflon tape.
- (2) Install elbow (8) on fill solenoid (7).
- (3) Install elbow (6) and tee (5) on fill solenoid (7).
- (4) Loosen nut (9). Turn terminals of fill solenoid (7) so wires will connect easily to fill solenoid. Tighten nut (9).
- (5) Coat threads of elbow (4) with teflon tape.

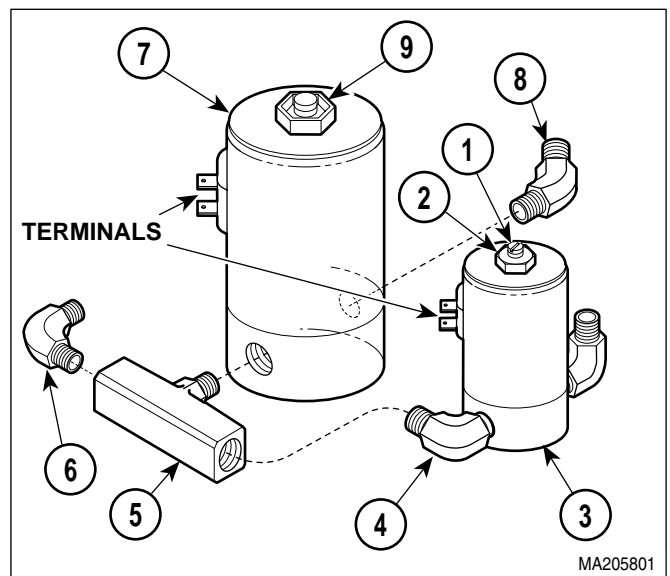

Figure 4-13. Fill Solenoid Fittings Removal / Installation

SECTION IV MAINTENANCE / SERVICE

- (6) Hold screw (1) and loosen nut (2). Turn terminals out of the way.
- (7) Install assembled elbow (4) and vent solenoid (3) on tee (5).
- (8) Turn terminals of vent solenoid (3) so wires will connect easily to vent solenoid.
- (9) Hold screw (1) and tighten nut (2).



EQUIPMENT ALERT

When installing the vent solenoid and the fill solenoid, the side of the solenoids marked "IN" need to be connected to the pressure lines. Reversing solenoids will cause system failure.

- (10) Install spacer (12A, Figure 4-12) and manifold assembly (12) on base (13) and secure using two screws (11).
- (11) Connect three tubes (5 thru 7) to elbows (8 thru 10).
- (12) Connect two wires (2) to terminals (4).
- (13) Connect two wires (1) to terminals (3).
- (14) Install back panel (Refer to para 4.5).
- (15) Refill condensing tank with distilled water.

4.13 Control PC Board Removal / Installation

A. Removal

- (1) Remove right hand side panel (Refer to para 4.3).
- (2) Disconnect pressure tube (1, Figure 4-14) from pressure sensor (2).

NOTE

Units with old style control PC board with EPROM version N or after **or** new style control PC board will only have two wire harnesses (3) to disconnect instead of three.

- (3) Disconnect two / three wire harnesses (3) from two / three connectors (4).

- (4) Tag and disconnect two wires (5) from terminals (6).
 - (5) Tag and disconnect two wires (7) from terminals (8).
 - (6) Disconnect ribbon connector (9) from connector (10).
 - (7) Tag and disconnect neutral wire (11) from terminal (12).
 - (8) Tag and disconnect hot wire (13) from terminal (14).
 - (9) Disconnect printer cable (15) from connector (16).
 - (10) Disconnect door switch harness (17) from connector (18).
- M9 / M11 only
- (11) Tag and disconnect two wires (19) from pulse solenoid terminals (20).
 - (12) Disconnect heater element wire (21) from connector (22).

NOTE

Positions of locknuts (1) and screws (2) are reversed on newer units.

- (13) Remove two locknuts (1, Figure 4-15), screws (2), and control PC board (3) and control PC board bracket (4) as an assembly from base (5).

NOTE

Units prior to serial number CZ1110/OM1000 have the ground wire attached to the control PC board bracket. When nut (6), starwasher (7), and screw (8) are removed, ground wire will also be removed.

- (14) Remove nut (6), starwasher (7), and screw (8) from control PC board bracket (4).
- (15) Turn three standoff screws (9) 1/4 turn in the counter-clockwise direction and remove control PC board (3) and insulator (10) from control PC board bracket (4).

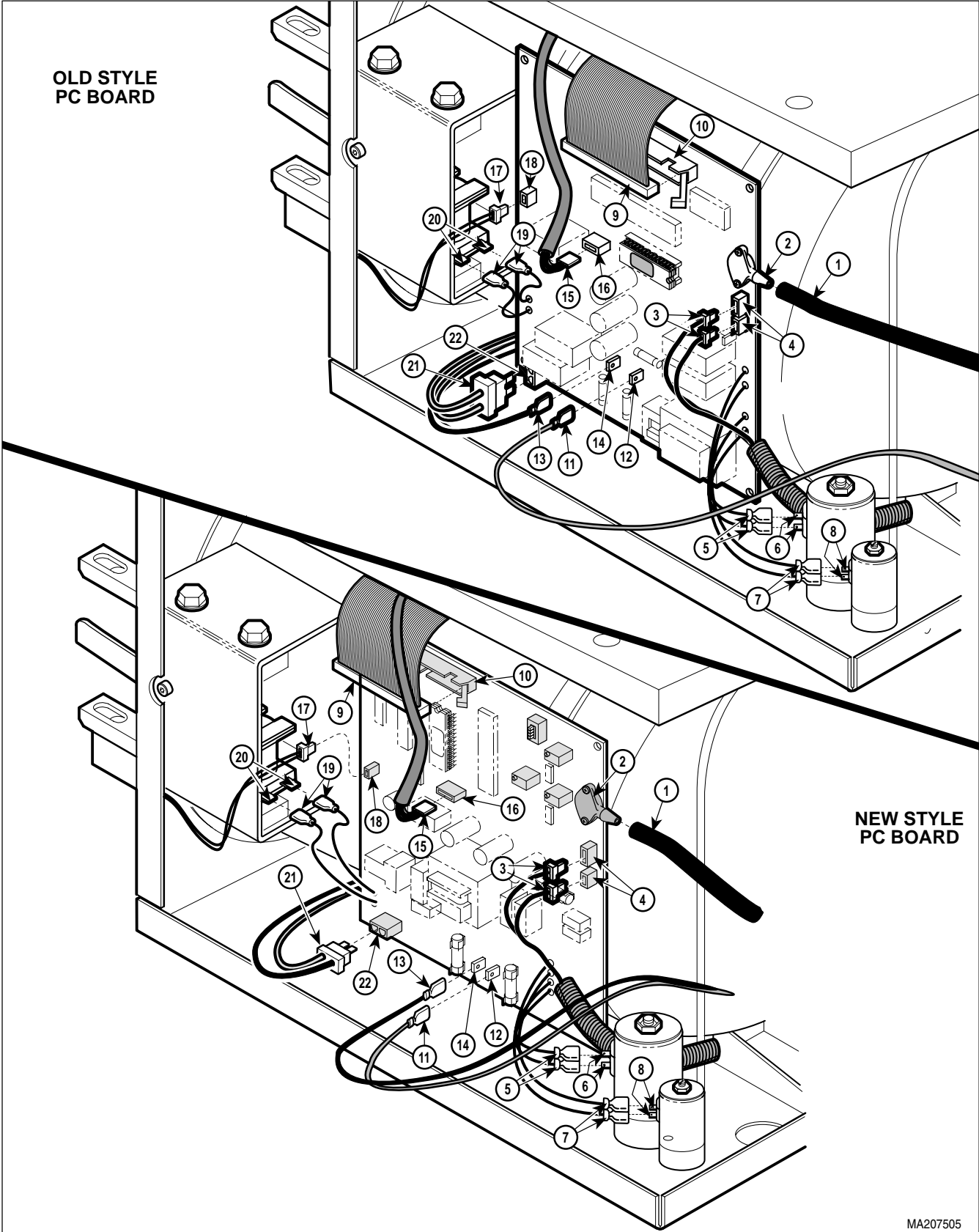

Figure 4-14. Control PC Board Connections

SECTION IV MAINTENANCE / SERVICE

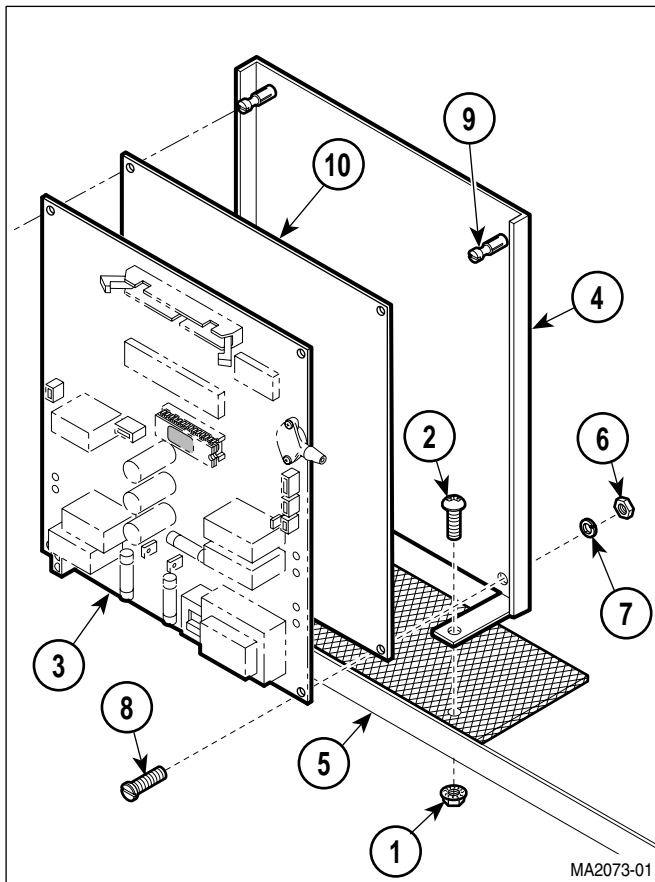

Figure 4-15. Control PC Board Removal / Installation

B. Installation

- (1) Install insulator (10, Figure 4-15) and control PC board (3) on control PC board bracket (4) and secure by turning three standoff screws (9) 1/4 turn in the clockwise direction.

NOTE

Units prior to serial number CZ1110/OM1000 have the ground wire attached to the control PC board bracket. When nut (6), starwasher (7), and screw (8) are removed, ground wire will also be removed. Make sure ground wire is re-installed upon installation.

- (2) Install screw (8), starwasher (7), and nut (6) on control PC board bracket (4).

NOTE

Positions of locknuts (1) and screws (2) are reversed on newer units.

- (3) Install control PC board (3) and control PC board bracket (4) as an assembly on base (5) and secure using two screws (2) and lock-nuts (1).
 - (4) Connect heater element wire (21, Figure 4-14) to connector (22).
- M9 / M11 only
- (5) Connect two wires (19) on pulse solenoid terminals (20).
 - (6) Connect wire harness (17) to connector (18).
 - (7) Connect printer cable (15) to connector (16).
 - (8) Connect hot wire (13) to terminal (14).
 - (9) Connect neutral wire (11) to terminal (12).
 - (10) Connect ribbon connector (9) to connector (10).
 - (11) Connect two wires (7) to terminals (8).
 - (12) Connect two wires (5) to terminals (6).

NOTE

Units with old style control PC board with EPROM version N or after **or** new style control PC board will only have two wire harnesses (3) to connect instead of three.

- (13) Connect two / three wire harnesses (3) to two / three connectors (4).
- (14) Connect pressure tube(1) to pressure sensor (2).
- (15) Install right hand side panel (Refer to para 4.3).

4.14 Door Switch Removal / Installation

A. Removal

NOTE

Units prior to serial number CZ1110/OM1000 have a different switch weldment. Since this procedure tampers with the pressure vessel integrity, it should not be attempted until a Midmark service representative has been contacted.

- (1) Open sterilizer door.
- (2) Remove right hand side panel (Refer to para 4.3).
- (3) Disconnect wire harness (1, Figure 4-16) from connector (2).
- (4) Using 3/32 in. punch, remove two roll pins (3) from door switch bracket (4) (Refer to Table 1-2 for special tool).
- (5) Remove door switch (5) from door switch bracket (4).

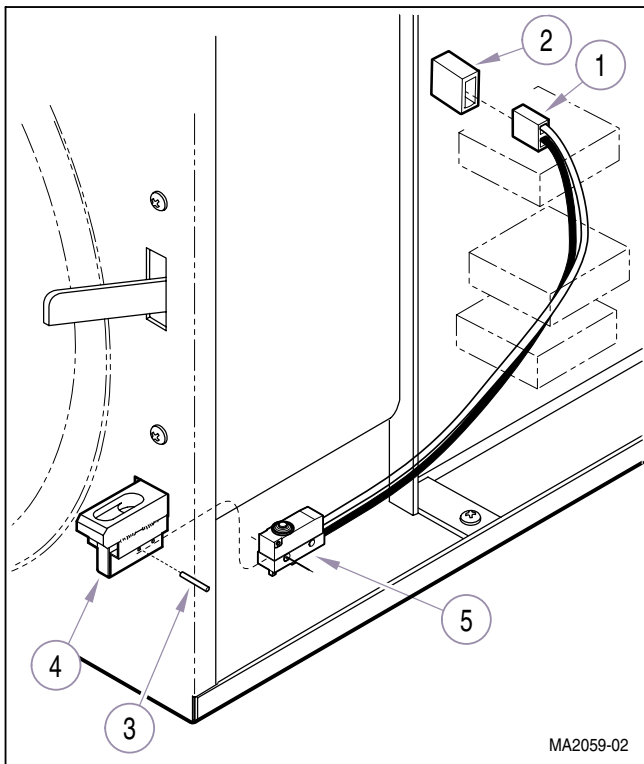

Figure 4-16. Door Switch Removal / Installation

B. Installation

- (1) Position door switch (5) in door switch bracket (4).
- (2) Using 3/32 in. punch, install two roll pins (3) in door switch bracket (4) (Refer to Table 1-2 for special tool).
- (3) Connect wire harness (1) to connector (2).
- (4) Install right hand side panel (Refer to para 4.3).
- (5) Close sterilizer door.

4.15 Pulse Solenoid Removal / Installation (M9 / M11 only)

A. Removal

- (1) Remove control PC board (Refer to para 4.13).
- (2) Remove two screws (1, Figure 4-17) from pulse solenoid (2).
- (3) Remove nut (3) and shoulder screw (4), and then remove pulse solenoid (2) and latch lever (5) as an assembly from pressure vessel bracket (6).
- (4) Using 3/32 in. punch, remove roll pin (7) and latch lever (5) from plunger of pulse solenoid (2) (Refer to Table 1-2 for special tool).

B. Installation

- (1) Using 3/32 in. punch, install latch lever (5) on plunger of pulse solenoid (2) and secure using roll pin (7) (Refer to Table 1-2 for special tool).
- (2) Coat shoulder screw (4) with Loctite 271.
- (3) Install latch lever (5) and pulse solenoid (2) as an assembly on pressure vessel bracket (6). Secure using shoulder screw (4) and nut (3).

SECTION IV MAINTENANCE / SERVICE

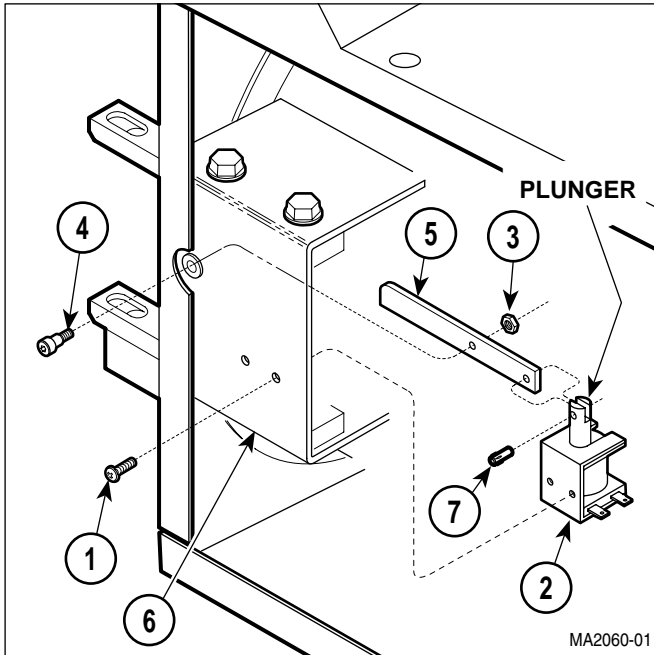

Figure 4-17. Pulse Solenoid Removal / Installation

NOTE

The holes for the two screws (1) are oblong. Install screws at the top of each hole first, then adjust downward as necessary if door will not open.

- (4) Position pulse solenoid (2) on pressure vessel bracket (6) and secure in position using two screws (1).
- (5) Install control PC board (Refer to para 4.13).

4.16 Thermostat Removal / Installation

A. Removal

- (1) Drain water from condensing tank.
- (2) Remove base inspection cover (Refer to para 4.6).
- (3) Tag and disconnect wires (1 and 2, Figure 4-18) from terminals (3 and 4).
- (4) Loosen two nuts (5) and pull top of bracket (6) approximately 1 in. from pressure vessel (7).
- (5) Rotate terminals (3 and 4) to a vertical position and slide thermostat (8) upward and out of bracket (6).

B. Installation

- (1) Slide thermostat (8) into bracket (6) and rotate terminals (3 and 4) to a horizontal position.
- (2) Position bracket (6) against pressure vessel (7) and secure by tightening two nuts (5).
- (3) Connect wires (1 and 2) to terminals (3 and 4).
- (4) Install base inspection cover (Refer to para 4.6).
- (5) Refill condensing tank with distilled water.

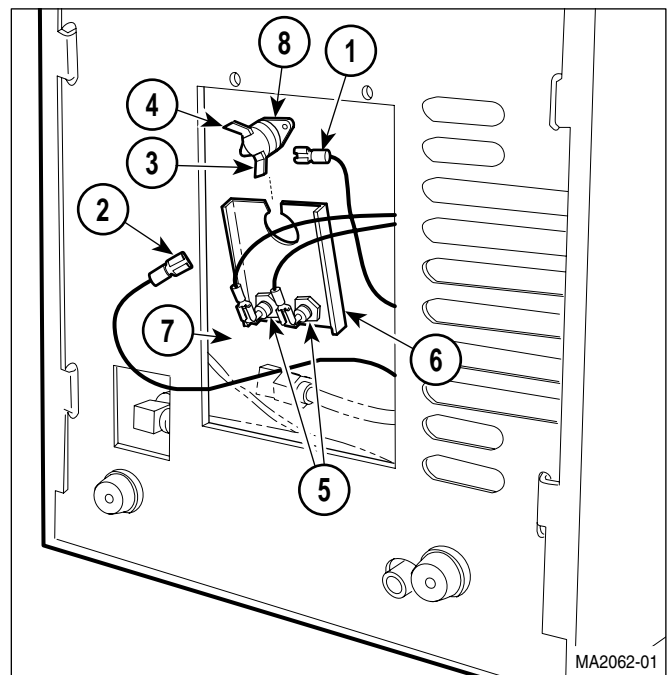

Figure 4-18. Thermostat Removal / Installation

4.17 Wire Tray Rack and Tray Plate Removal/Installation

A. Removal

- (1) Open sterilizer door.
- (2) Remove trays.
- (3) Pull wire tray rack (1, Figure 4-19) and tray plate (2) from pressure vessel (3).

B. Installation

- (1) Position two rear posts of wire tray rack (1) in rack holes of tray plate (2).
- (2) Hold front end of wire tray rack (1) at approximately a 30° angle from tray plate (2).

NOTE

If wire tray rack is not raised, installation is very difficult.

- (3) Insert rear end of wire tray rack (1) and tray plate (2) as an assembly in pressure vessel (3). Push wire tray rack and tray plate as far as they will go.

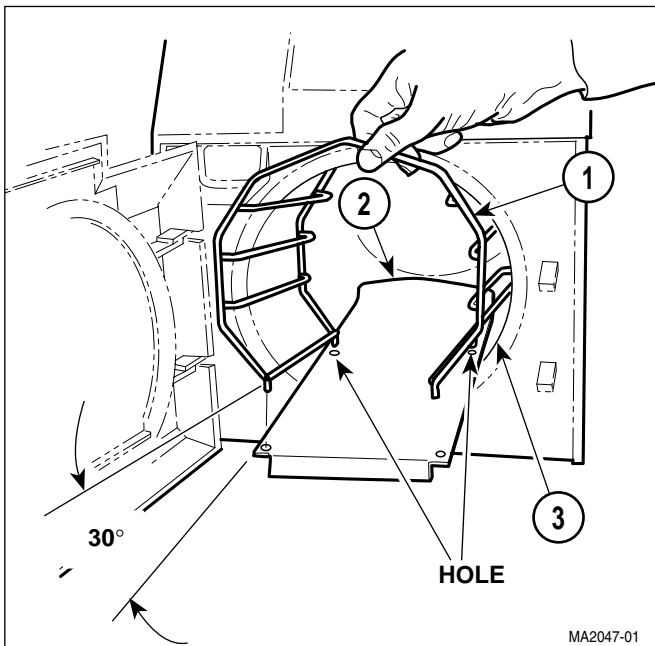

Figure 4-19. Wire Tray Rack and Tray Plate Removal/Installation

- (4) Install trays.
- (5) Close sterilizer door.

4.18 Heating Element and Gasket Removal/Installation

A. Removal

- (1) Drain water from condensing tank.
- (2) Remove base inspection cover (Refer to para 4.6).
- (3) Tag and disconnect two wires (1, Figure 4-20) from terminals (2).
- (4) Remove two nuts (3), lock washers (4), and brass washers (5).



EQUIPMENT ALERT

Over bending may result in broken or cracked terminals.

NOTE

The following step is necessary to remove the heating element from the pressure vessel.

- (5) Straighten terminals (2) slightly from the present 90° position to approximately a 10° straighter position.
- (6) Remove bracket (6) from pressure vessel (7) and position out-of-way.
- (7) Turn sterilizer upright.
- (8) Remove wire tray rack and tray plate (Refer to para 4.17).
- (9) Remove heating element (8) and spacer assembly (9) from pressure vessel (7).

NOTE

Perform the following step only if the heating element is *not* being replaced, but damaged gaskets are.

- (10) Remove two gaskets (10) from heating element (8).

SECTION IV MAINTENANCE / SERVICE

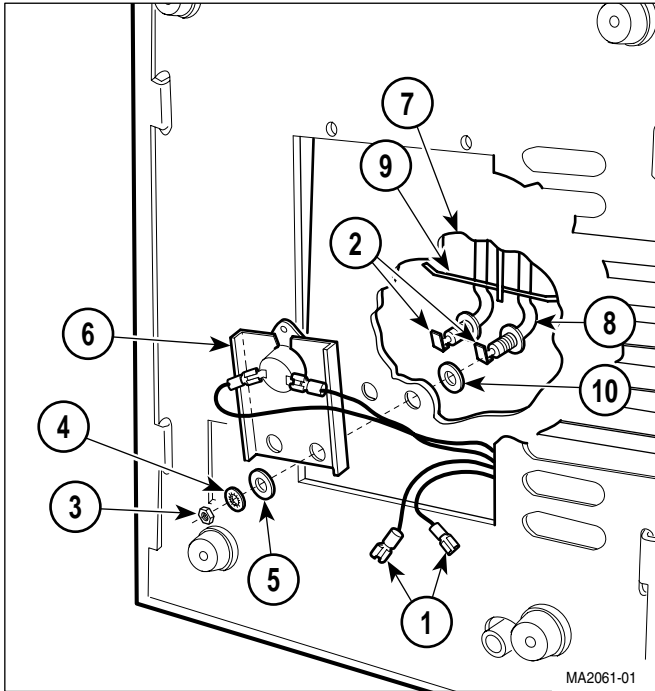

Figure 4-20. Heating Element and Gasket Removal / Installation

B. Installation

- (1) Install two gaskets (10) on heating element (8).



EQUIPMENT ALERT

Over bending may result in broken or cracked terminals.

NOTE

The following step is necessary to install the heating element in the pressure vessel.

- (2) Straighten terminals (2) slightly from the present 90° position to approximately a 10° straighter position.
- (3) Install spacer assembly (9) and heating element (8) in pressure vessel (7).
- (4) Turn sterilizer on its back.
- (5) Position bracket (6) on pressure vessel (7).



EQUIPMENT ALERT

Hold heating element firmly in position while tightening nuts. Otherwise, damage to heating element or improper positioning of heating element may result. Also, spacer assembly must remain above gaskets. If spacer assembly is installed under gasket, leaking will result.

- (6) Install two brass washers (5), lock washers (4), and nuts (3) on heating element (8).



EQUIPMENT ALERT

Over bending may result in broken or cracked terminals.

- (7) Bend terminals (2) slightly, back to their original 90° position.
- (8) Connect two wires (1) to terminals (2).
- (9) Turn sterilizer upright.
- (10) Install wire tray rack and tray plate (Refer to para 4.17).
- (11) Install base inspection cover (Refer to para 4.6).
- (12) Refill condensing tank with distilled water.

4.19 Filter Removal / Installation

A. Removal

- (1) Remove wire tray rack and tray plate (Refer to para 4.17).

NOTE

Turn filter in a circular motion while pulling upward to remove.

- (2) Using vise grips, remove filter (1, Figure 4-21) from pressure vessel (2).

B. Installation

- (1) Position filter (1) in pressure vessel (2).

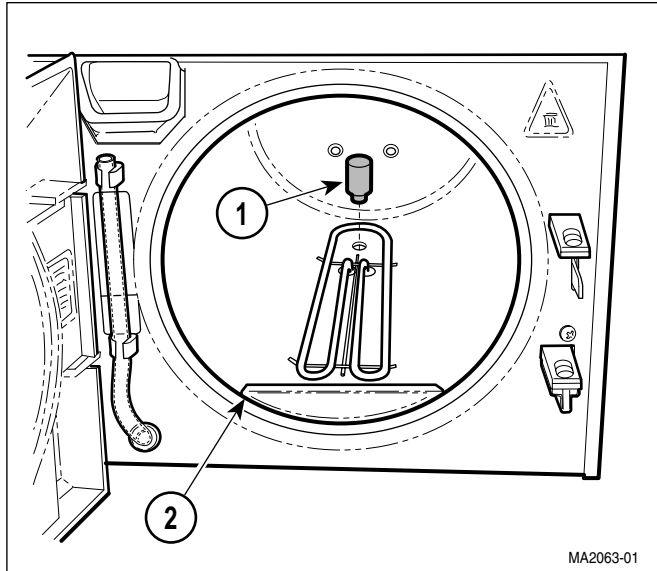

Figure 4-21. Filter Removal / Installation

- (2) Using rubber hammer, tap filter (1) lightly into pressure vessel (2).
- (3) Install wire tray rack and tray plate (Refer to para 4.17).

4.20 Door Gaskets Removal / Installation

A. Removal

- (1) Open sterilizer door.
- (2) Remove dam gasket (1, Figure 4-22) and door gasket (2) from door (3).

B. Installation

- (1) Install door gasket (2) in groove in door (3).

NOTE

Some models may have two mounting pins on door instead of flap. Secure dam gasket by pressing onto mounting pins.

- (2) Install dam gasket (1) by inserting bottom edge of dam gasket in slot of door gasket (2) and tucking top edge of dam gasket under flap of door (3).
- (3) Close sterilizer door.

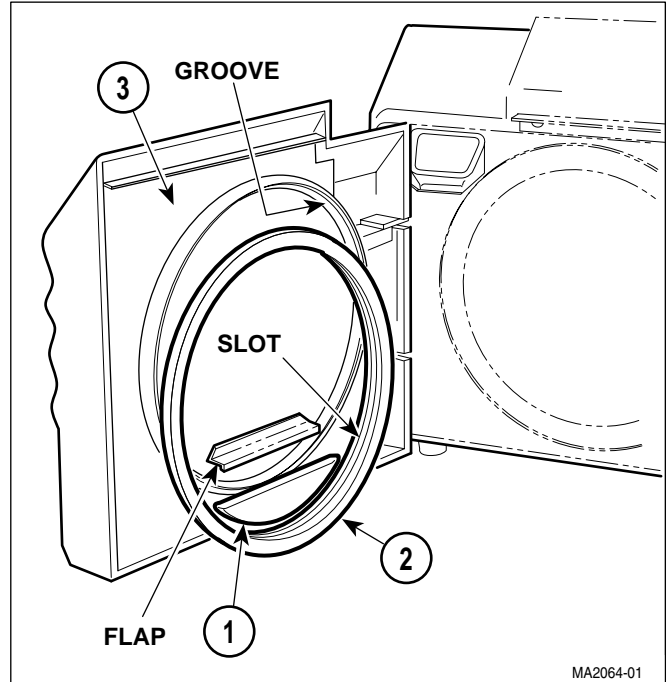

Figure 4-22. Door Gaskets Removal / Installation

4.21 Display PC Board Removal / Installation

A. Removal

- (1) Remove top cover (Refer to para 4.2).
- (2) Remove six screws (1, Figure 4-23) and display PC board (2) from top cover (3).
- (3) If damaged, remove gasket (4) from top cover (3).

B. Installation

- (1) If removed, install new gasket (4) by peeling protective backing off of gasket and pressing gasket firmly into position on top cover (3).
- (2) Install display PC board (2) on top cover (3) and secure using six screws (1).
- (3) Install top cover (Refer to para 4.2).

SECTION IV MAINTENANCE / SERVICE

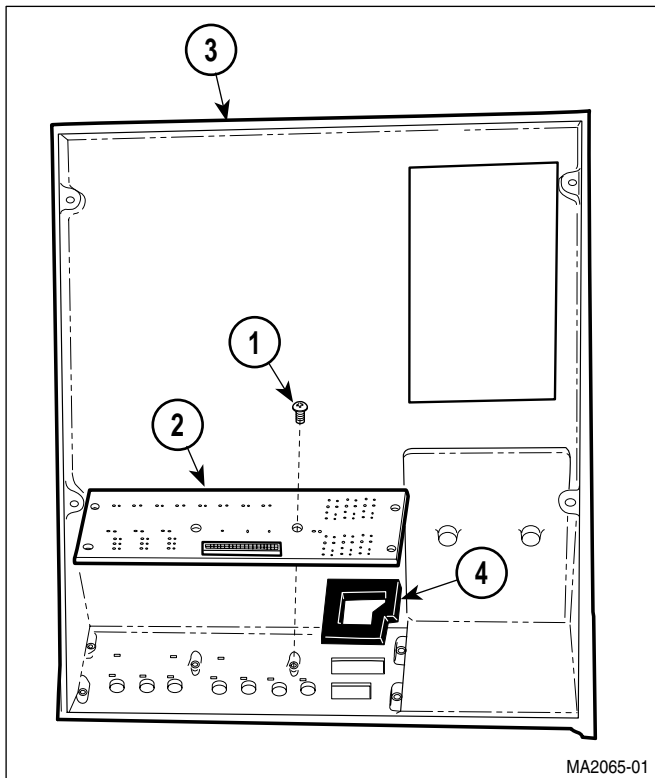
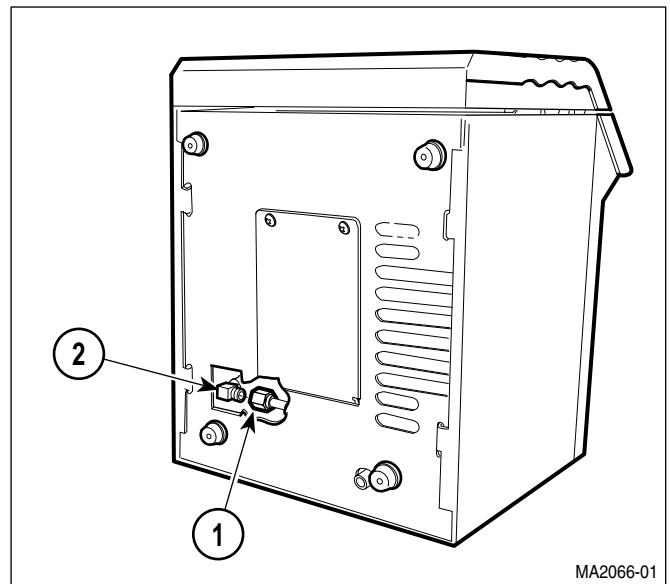

**Figure 4-23. Display PC Board
Removal / Installation**

4.22 Condensing Tank Assembly Removal / Installation

A. Removal

- (1) Drain water from condensing tank.
- (2) Turn sterilizer onto its back.
- (3) Disconnect fill tube (1, Figure 4-24) from elbow (2).
- (4) Turn sterilizer upright.
- (5) Remove top cover (Refer to para 4.2).
- (6) Remove back panel (Refer to para 4.5).
- (7) Remove bellows assembly (Refer to para 4.7).
- (8) Loosen hose clamp (1, Figure 4-25) and remove sight/drain tube (2) and hose clamp from condensing tank assembly (3).



**Figure 4-24. Condensing Tank Assembly Fill Tube
Disconnection / Connection**

NOTE

The following step applies only to units with old style control PC board with EPROM version M or before. Units with old style control PC board with EPROM version N or after **or** new style control PC board do not have wire (4) and terminal (5).

(9) Disconnect wire (4) from terminal (5).

(10) Disconnect vent tube (6) from fitting (7).

NOTE

Positions of locknut (9) and screws (8) are reversed on newer units.

(11) Remove screw (8), locknut (9), and condensing tank assembly (3) from base (10).

B. Installation

NOTE

Fill tube must be lined up with fitting at this time because it will be impossible to line up after screw and locknut are installed.

(1) Position condensing tank assembly (3, Figure 4-25) on base (10) and secure using screw (8) and locknut (9).

(2) Connect vent tube (6) to fitting (7).

NOTE

The following step applies only to units with old style control PC board with EPROM version M or before. Units with old style control PC board with EPROM version N or after **or** new style control PC board do not have wire (4) and terminal (5).

- (3) Connect wire (4) to terminal (5).
- (4) Install hose clamp (1) and sight/drain tube (2) on condensing tank assembly (3). Tighten hose clamp.
- (5) Install bellows assembly (Refer to para 4.7).
- (6) Install back panel (Refer to para 4.5).
- (7) Install top cover (Refer to para 4.2).
- (8) Turn sterilizer onto its side.
- (9) Connect fill tube (1, Figure 4-24) to elbow (2).
- (10) Turn sterilizer upright.
- (11) Refill condensing tank with distilled water.

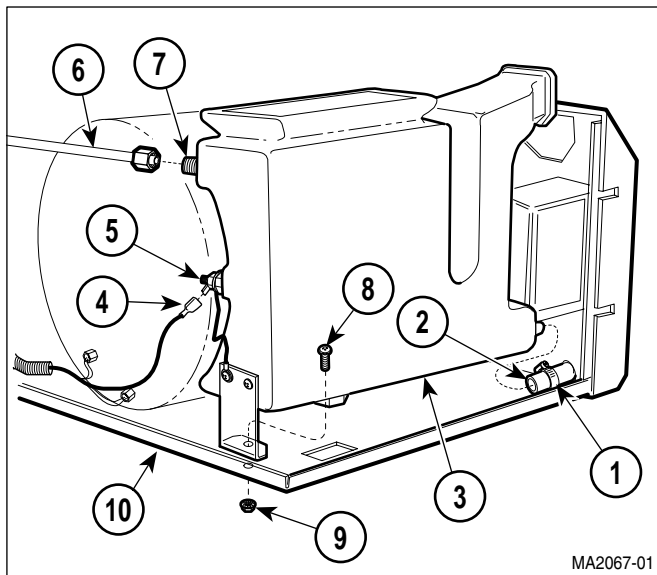

Figure 4-25. Condensing Tank Assembly Removal / Installation

4.23 Pressure Relief Valve Removal / Installation

A. Removal

- (1) Remove condensing tank assembly (Refer to para 4.22).
- (2) Disconnect tube (1, Figure 4-26) from elbow (2).
- (3) Remove elbow (2) from pressure relief valve (3).
- (4) Remove pressure relief valve (3) from pressure vessel (4).

B. Installation

- (1) Coat threads of pressure relief valve (3) and elbow (2) with teflon tape.
- (2) Install pressure relief valve (3) in pressure vessel (4).
- (3) Install elbow (2) on pressure relief valve (3).
- (4) Connect tube (1) to elbow (2).
- (5) Install condensing tank assembly (Refer to para 4.22).

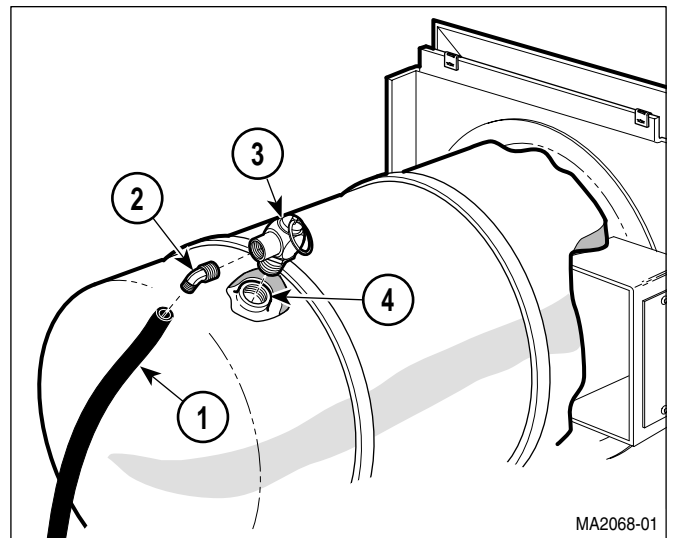

Figure 4-26. Pressure Relief Valve Removal / Installation

SECTION IV MAINTENANCE / SERVICE

4.24 Pressure / Temperature Potentiometers Adjustments



EQUIPMENT ALERT

The pressure zero, pressure range, and temperature potentiometers cannot be adjusted separately. If one potentiometer needs adjusted, then the entire potentiometer adjustment procedure must be performed, and it must be performed in the proper sequence as follows:

- (1) Remove right hand side panel.
- (2) Open sterilizer door.



DANGER

The following steps require the sterilizer to be plugged in to power while the adjustment is being performed. Do not touch any components except for the adjusting screw of the potentiometer. Failure to comply with these instructions could result in an electrical shock, which could result in severe personal injury or death.

NOTE

After the following step is performed, the display PC board lamps will individually illuminate and then extinguish one at a time in a left to right sequence. When all the lamps have illuminated and extinguished, proceed with step 4.

- (3) Press and hold down the LIQUIDS and PACKS buttons simultaneously while connecting the power cord to the sterilizer (See Figure 4-27). Release the LIQUIDS and PACKS buttons.

NOTE

When each button is pressed, its corresponding lamp will illuminate and stay illuminated. Also, after the following step, the PRESSURE (PSI) display will display the pressure that the control PC board is reading and the TEMP (°F) / TIME (MIN: SECONDS) display will display the temperature that the control PC board is reading. When each button has been pushed, proceed with step 5.

- (4) Press and release the UNWRAPPED, POUCHES, LIQUIDS, PACKS, START, STOP, AND ON/STANDBY buttons one at a time and in this order.

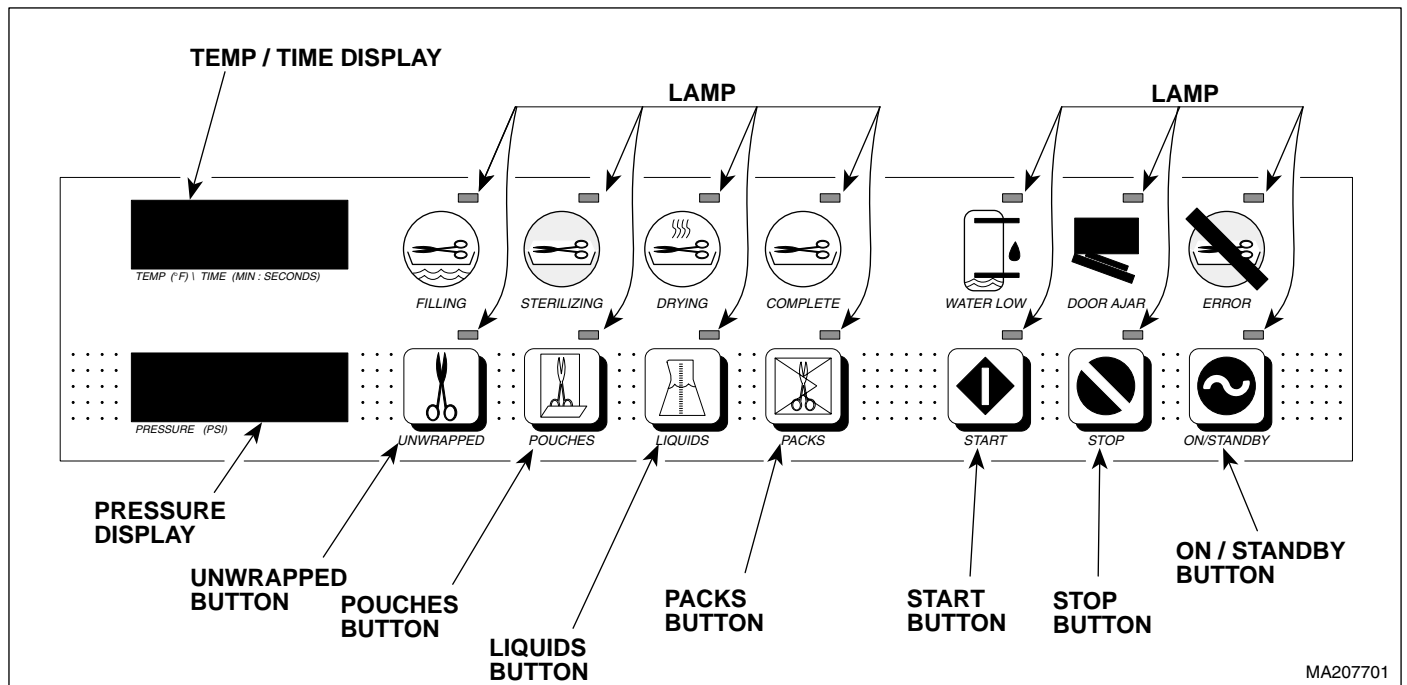

Figure 4-27. Display PC Board Lamp / Display / Button Check (M9 / M11 shown)

- (5) Turn adjusting screw of pressure zero potentiometer (1, Figure 4-28) in the counter-clockwise direction until the PRESSURE (PSI) display reads 0.0 psi (0.0 kPa).
- (6) Turn adjusting screw of pressure zero potentiometer (1) in the clockwise direction until the PRESSURE (PSI) display reads 0.1 psi (1 kPa).



CAUTION

The multimeter leads must be connected exactly as shown in the illustration. Connecting a lead to the wrong side of the resistor or wrong pin of the chip will result in an incorrect adjustment.

- (7) Set the multimeter to read VDC at least the 5 Volts range. Connect the red lead of a multimeter to Test Point (A) and the black lead of a multimeter to Test Point (B).

NOTE

In the following step, if the digital multimeter being used has only three digits, adjust to a reading of 2.54 VDC and then adjust and set to where the reading just changes to 2.55 VDC.

- (8) The multimeter should read 2.550 VDC \pm 0.001 VDC. If multimeter reading is not 2.550 VDC \pm 0.001 VDC, adjust the adjusting screw of the temperature potentiometer (3) in a clockwise direction to lower the voltage setting or a counter-clockwise direction to raise the voltage setting until the multimeter reading is 2.550 VDC \pm 0.001 VDC.
- (9) Close the sterilizer door.
- (10) Connect Pressure Gauge Test Harness to sterilizer (See Figure 4-29) (Refer to the sterilizer Service and Parts Manual for this special tool).
- (11) Press the START button to start a test/calibration cycle and wait until the temperature on the TEMP (°F) / TIME (MIN: SECONDS) display reaches 272 - 273°F (133-134°C) (See Figure 4-27).

NOTE

Turning the adjusting screw of the pressure range potentiometer in the clockwise direction raises the sterilizer pressure reading while turning the adjusting screw in the counter-clockwise direction lowers the sterilizer pressure reading.

- (12) Turn the adjusting screw of the pressure range potentiometer (2, Figure 4-28) in the clockwise or counter-clockwise direction until the reading on the PRESSURE (PSI) display matches the reading of the Pressure Gauge Test Harness within a tolerance of \pm 0.5 psi (3.5 kPa).
- (13) Recheck the multimeter reading. It should still read 2.550 VDC \pm 0.001 VDC.
- (14) Press the STOP button to end the test/calibration cycle and allow the sterilizer to vent and open its door (See Figure 4-27).
- (15) Disconnect the leads of the multimeter from Test Points (A and B, Figure 4-28).
- (16) Disconnect the power cord from the sterilizer and then repeat steps 3 and 4 of this procedure. The reading should read 0.1 psi (1 kPa) with the sterilizer door open. If not, repeat steps 5 and 6 of this procedure.
- (17) Disconnect the power cord from sterilizer.
- (18) Disconnect Pressure Gauge Test Harness from sterilizer (See Figure 4-29).
- (19) Install right hand side panel.

**SECTION IV
MAINTENANCE / SERVICE**

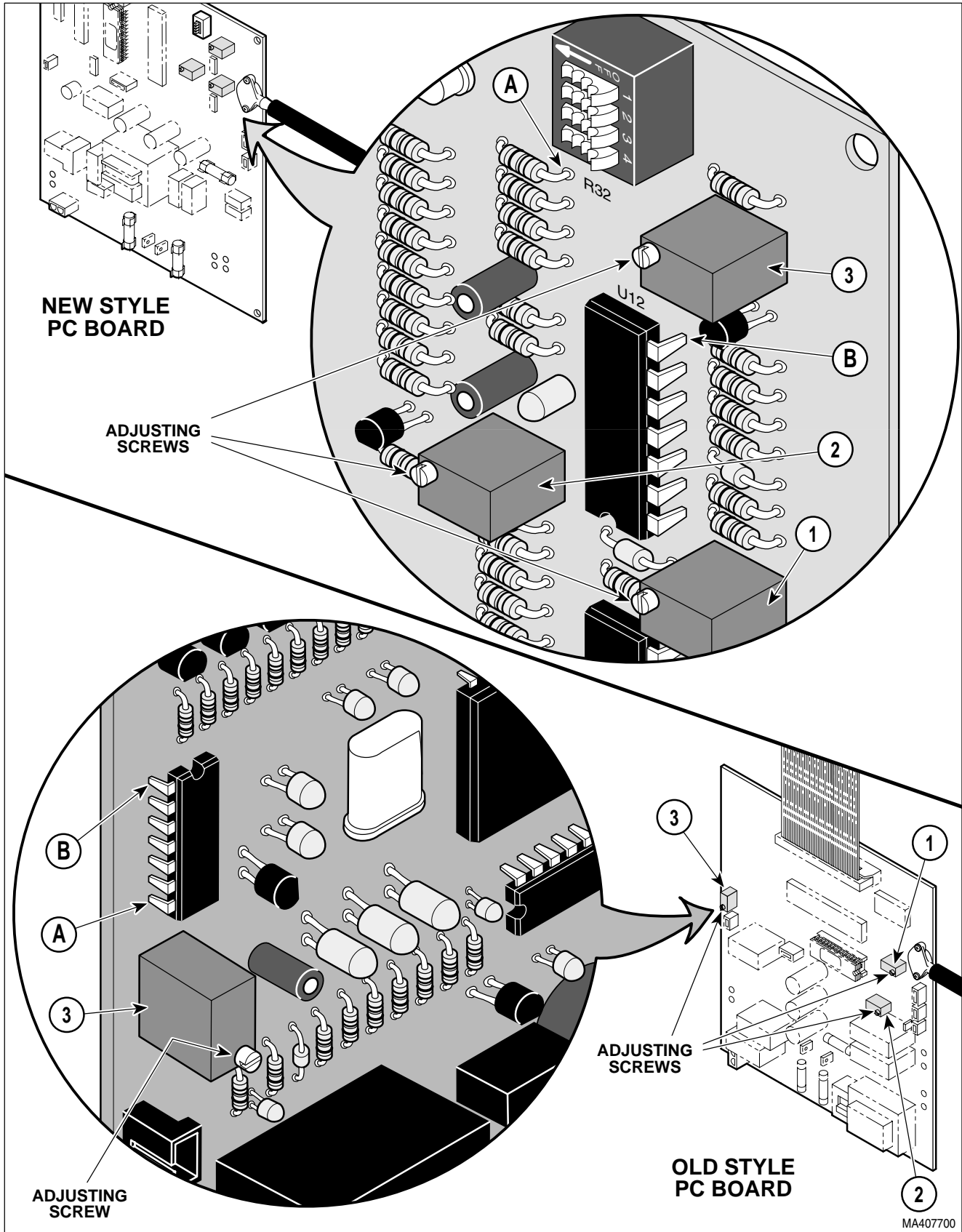
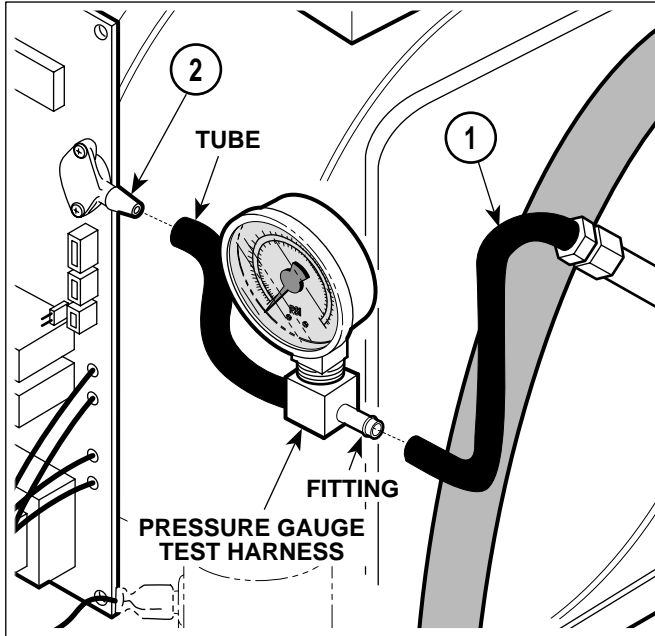

Figure 4-28. Potentiometer Adjustments

MA407700

4.25 Display PC Board Lamp / Display / Button Check



To connect Pressure Gauge Test Harness to sterilizer:

1. Disconnect tube (1) from pressure sensor (2).
2. Connect tube of Pressure Gauge Test Harness to pressure sensor (2).
3. Connect tube (1) to fitting of Pressure Gauge Test Harness.

To disconnect Pressure Gauge Test Harness from sterilizer:

1. Disconnect tube (1) from fitting of Pressure Gauge Test Harness.
2. Disconnect tube of Pressure Gauge Test Harness from pressure sensor (2).
3. Connect tube (1) to pressure sensor (2).

MA2070-01

Figure 4-29. Connecting / Disconnecting Pressure Gauge Test Harness

- (1) Disconnect power cord from the sterilizer.
- (2) Press and hold down the LIQUIDS and PACKS buttons simultaneously, while connecting the power cord to the sterilizer (See Figure 4-30). Release the LIQUIDS and PACKS buttons.
- (3) Observe the display PC board lamps. In a left to right sequence, each lamp on the display PC board should individually illuminate and then extinguish. If all the display PC board lamps do not illuminate and then extinguish, replace display PC board (Refer to para 4.21).
- (4) Press and release the UNWRAPPED, POUCHES, LIQUIDS, PACKS, START, STOP, AND ON/STANDBY buttons one at a time and in this order.
- (5) Observe the lamps that correspond with each button. If all lamps do not illuminate and stay illuminated when their corresponding button is pressed, replace the display PC board (Refer to para 4.21).
- (6) Observe the pressure and temperature/time displays. If the pressure and temperature/time displays do not display pressure and temperature readings, replace the display PC board (Refer to para 4.21).
- (7) Disconnect power cord from the sterilizer.

SECTION IV MAINTENANCE / SERVICE

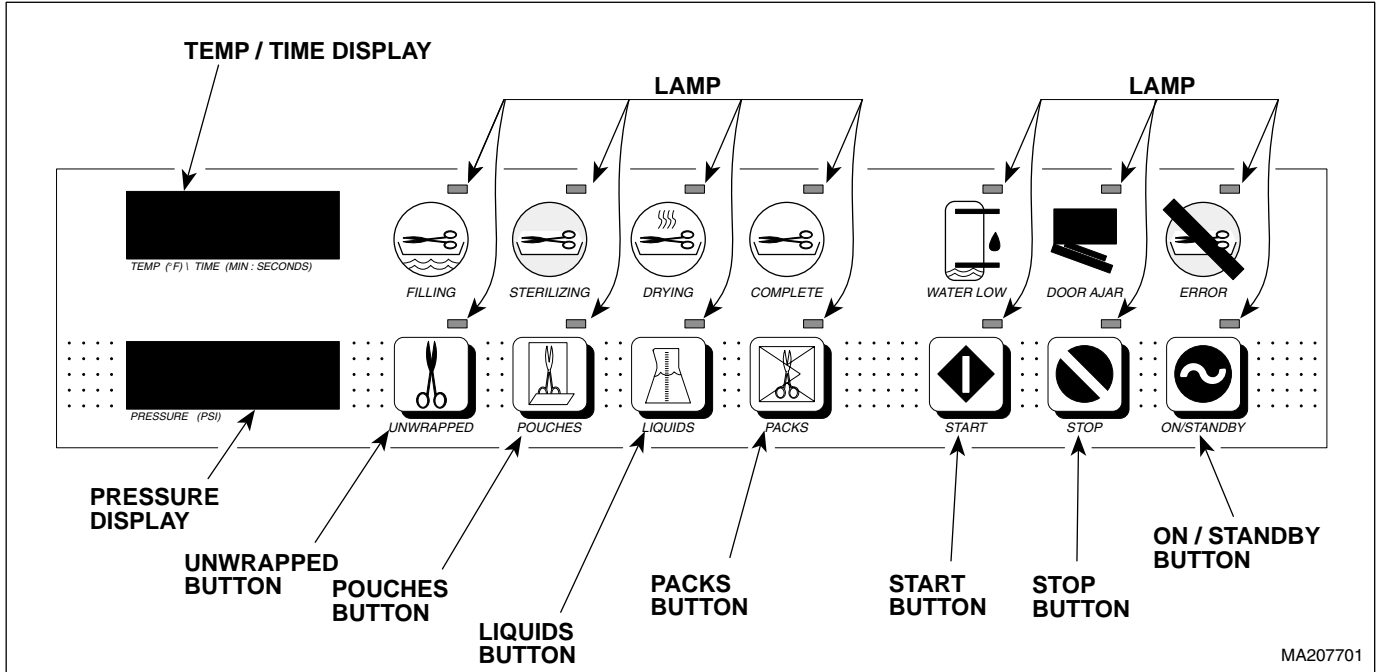

Figure 4-30. Display PC Board Lamp / Display / Button Check (M9 / M11 shown)

4.26 Pressure Relief Valve Check

- (1) Remove the top inspection cover (1, Figure 4-31).



WARNING

Refer to the operator manual for complete instructions on operating the sterilizer. Failure to do so could result in severe personal injury.

- (2) Select the UNWRAPPED cycle and start the cycle.



DANGER

Pressure Relief Valve will be hot. Use a screwdriver or rod to pull the wire ring. Do not pull the wire ring with bare hands or burns will result. Steam will be vented from under the rear of the sterilizer. To keep from being burned, place a steam barrier (a rolled up towel) around the bottom of the sterilizer.

- (3) When the “heat up” portion of the cycle is complete and the elapsed time is being counted down on the display PC board, pull on wire ring of pressure relief valve (2) with a screwdriver.

- (4) If excessive force was required to open pressure relief valve (2), replace the pressure relief valve (Refer to para 4.23).

NOTE

If the pressure relief valve does not close completely when the wire ring is released, pull the wire ring again and release it quickly so the valve snaps back into position. Do this until the valve seats properly.

- (5) Release wire ring of pressure relief valve (2). The steam should vent out of the pressure relief valve until the wire ring is released. When the wire ring is released, the valve should seat, stopping the release of steam.
- (6) If the pressure relief valve (2) will not re-seat properly, replace the pressure relief valve (Refer to para 4.23).
- (7) Install top inspection cover (1).

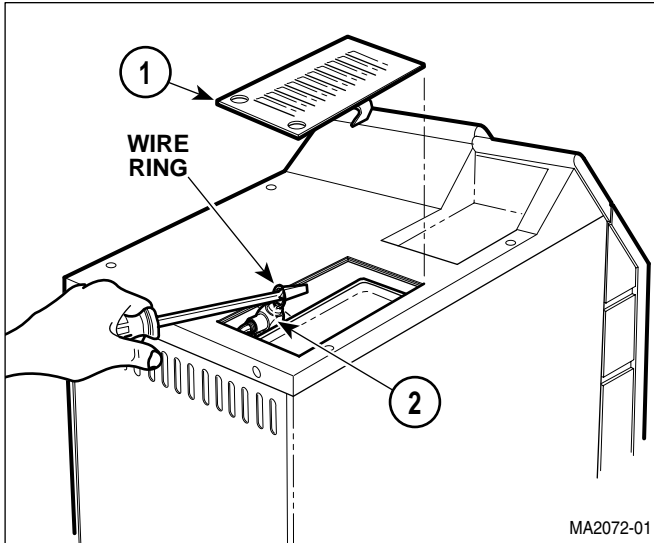

Figure 4-31. Pressure Relief Valve Check

4.27 Dry Cycle Dip Switches Adjustment

- (1) Unplug power cord from outlet receptacle.
- (2) Remove right hand side panel (Refer to para 4.3).

NOTE

There are four repeat interval dip switch settings; setting #1, setting #2, setting #3, and setting #4. The unit comes factory set at the repeat interval setting #3. Setting #1 is shortest repeat interval, setting #2 is longer, setting #3 is longer yet, and setting #4 is the longest repeat interval.

This procedure only applies to units with a new style control PC board; units with serial numbers: CZ2457, DA1005, DB1150, DX1970, DY1139, ES1347, ET1095, FD-1000, FP1000, FR1000, GB1000 and OM-9449 thru Present.

- (3) If unit has has been overheating during the drying cycle and activating the overheat thermostat, determine the current repeat interval dip switch settings for the unit per Figure 4-32 and then change the dip switch settings to the next shortest repeat interval.
- (4) Run a cycle. Repeat step 3 if overheat thermostat activates again.
- (5) Install right hand side panel (Refer to para 4.3).

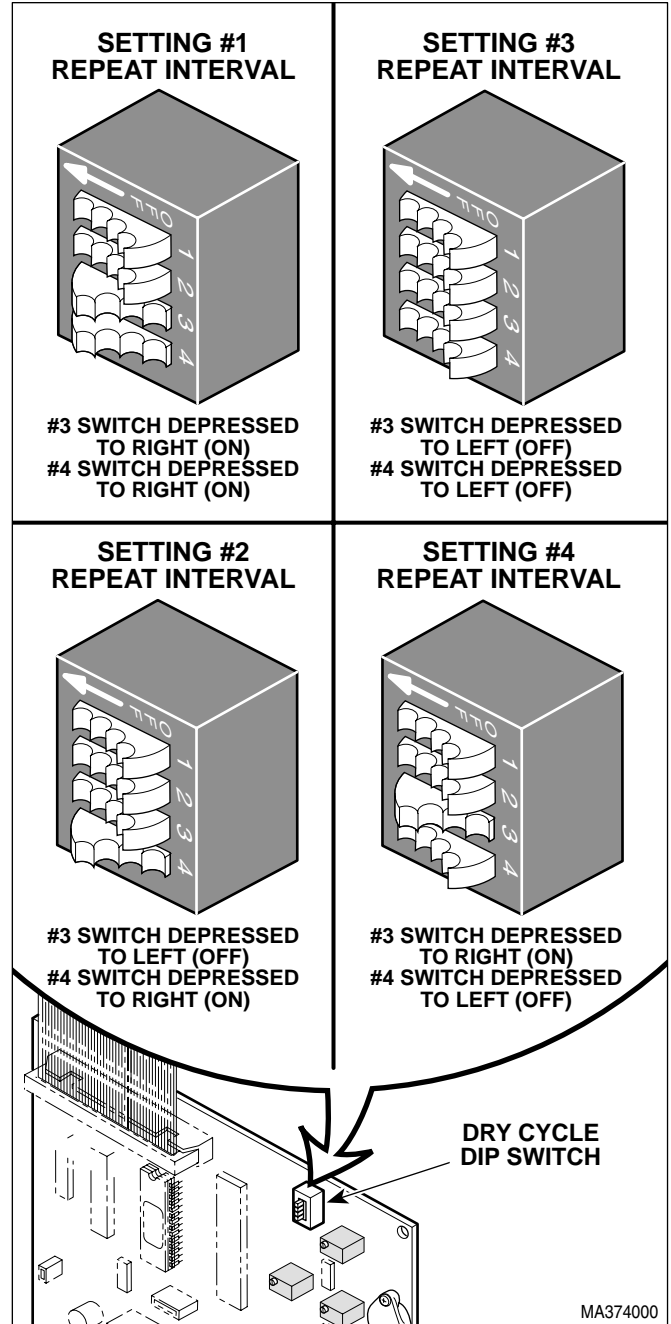

Figure 4-32. Dry Cycle Dip Switches Adjustment

SECTION IV MAINTENANCE / SERVICE

4.28 M9 / M11 Door Opening Test

NOTE
This test applies only to units with newer style PC boards.

- (1) Fill chamber with water. [To do this, start any cycle. After chamber has filled with water, the Sterilizing LED will illuminate]
- (2) Disconnect power cord.
- (3) Open door.
- (4) Press and hold **STOP & POUCHES** buttons (see Figure 4-33) while plugging in power cord.
- (5) Press and release all buttons from left to right across display panel.
- (6) Close door. [This will activate all relays in the sterilizer in sequence. Pulse solenoid should automatically open door when test cycle is complete].
- (7) To rerun test, repeat steps 2 thru 6.
- (8) To verify proper operation, run a complete cycle when test is complete.

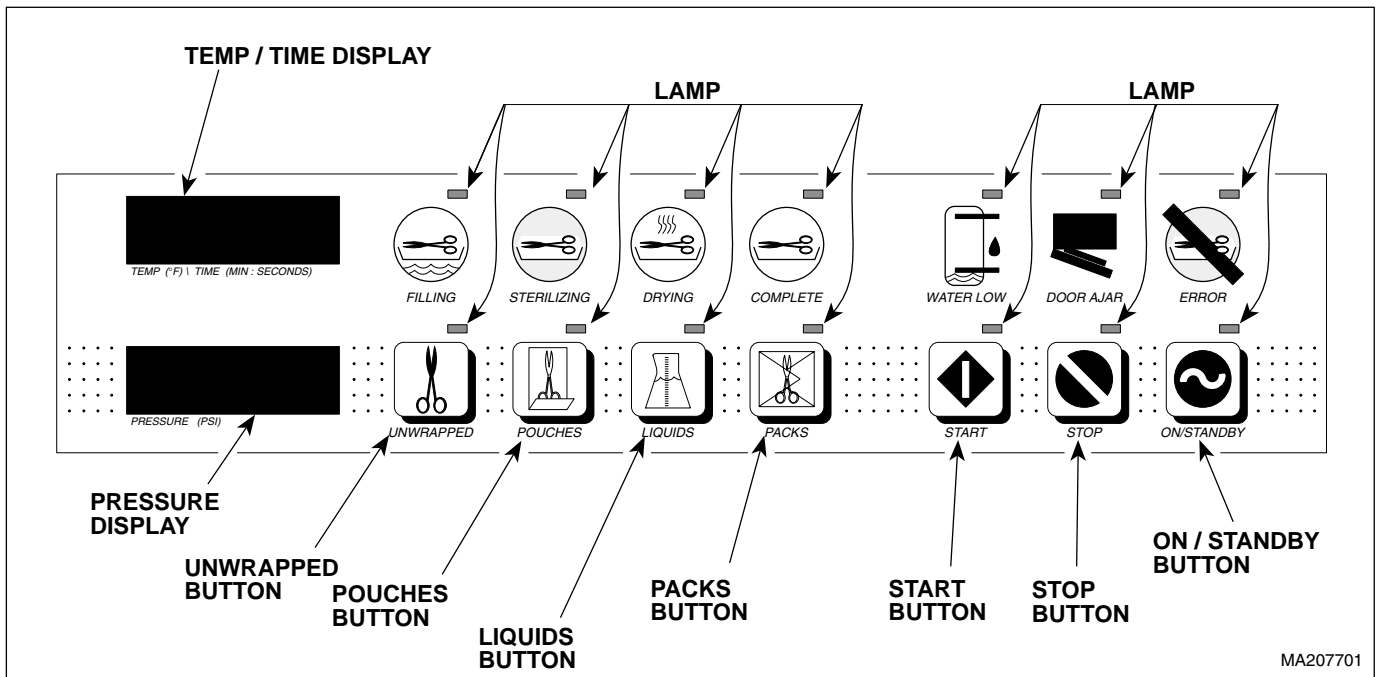

Figure 4-33. M9 / M11 Door Opening Test

**SECTION V
SCHEMATICS AND DIAGRAMS**

5.1 Wiring Diagrams

Figure 5-1 (sheets 1 thru 3) illustrate the wiring connections for the M9 sterilizer.

Figure 5-3 (sheets 1 thru 3) illustrate the wiring connections for the M11 sterilizer.

Figure 5-2 (sheets 1 & 2) illustrate the wiring connections for the M9D sterilizer.

Figure 5-4 (sheets 1 & 2) illustrate the wiring connections for the M11D sterilizer.

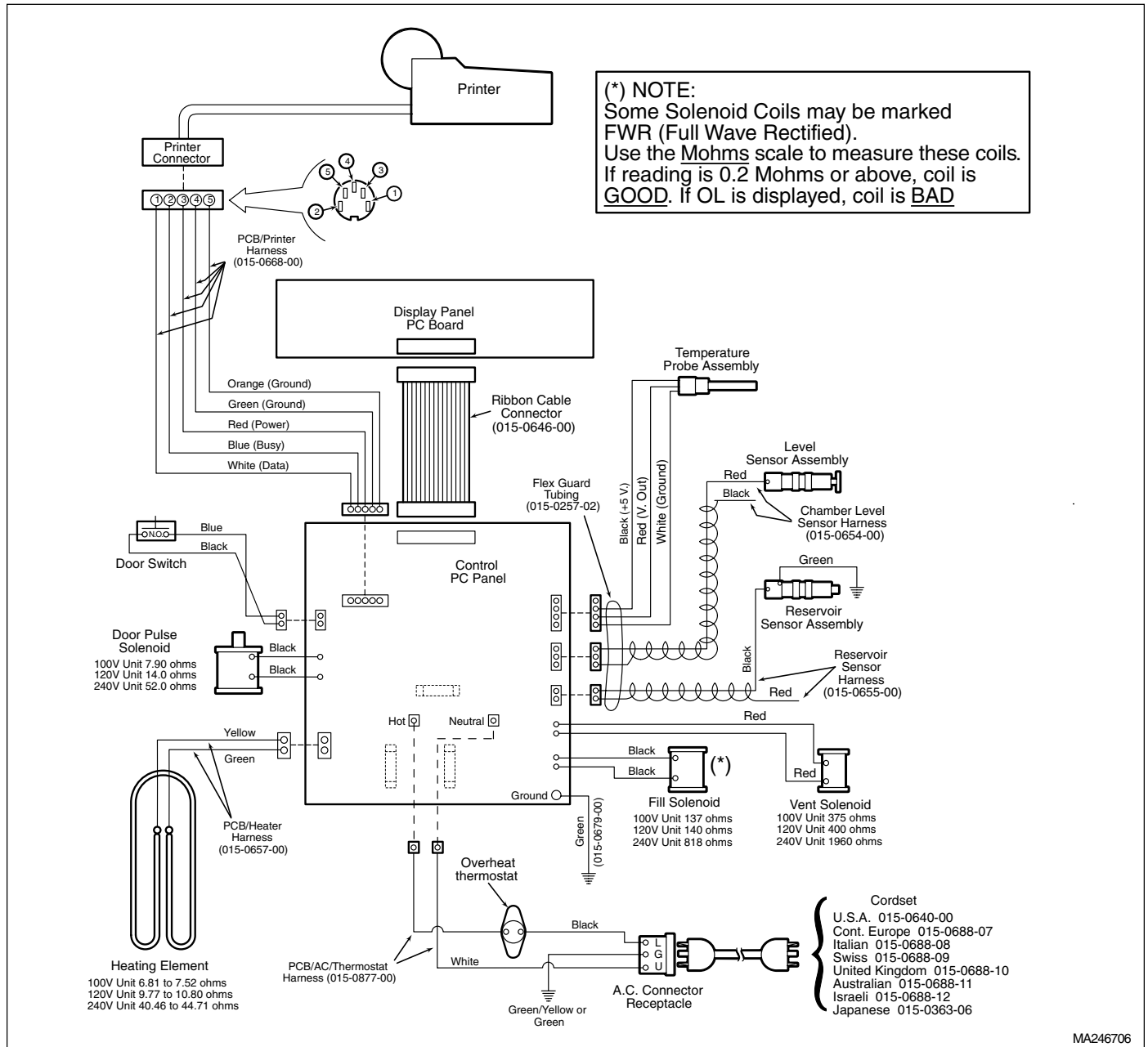

**Figure 5-1 (Sheet 1 of 3). M9 Wiring Diagram
(Applies To Serial Numbers CZ1000 thru CZ1684, DB1000 thru DB1010, OM1000 thru OM5130, DX1000 thru DX1170, DA1000 thru DA1001, and DY1000 thru DY1007)**

SECTION V SCHEMATICS AND DIAGRAMS

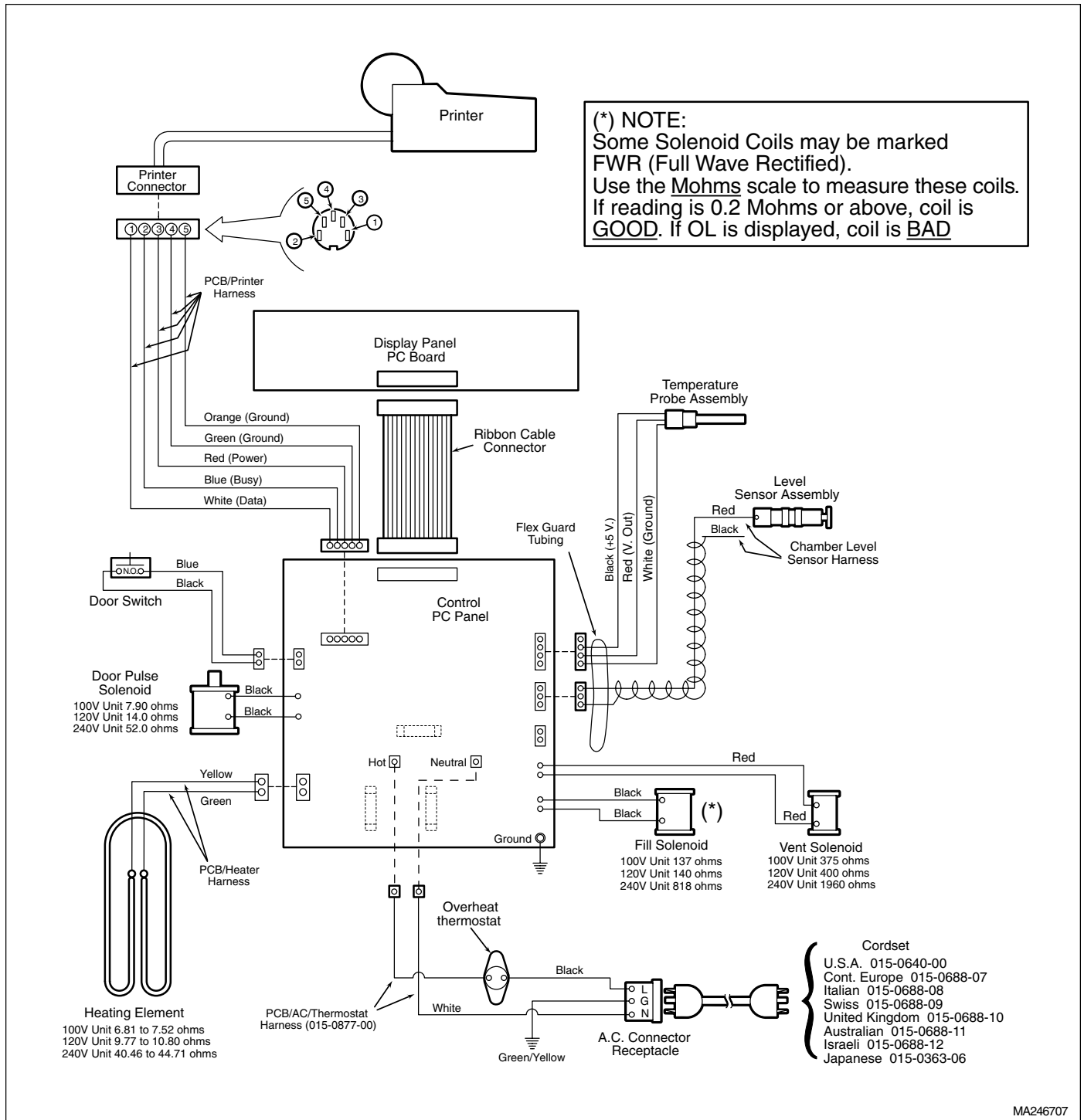

**Figure 5-1 (Sheet 2 of 3) M9 Wiring Diagram
(Applies To Serial Numbers CZ1685 thru CZ4590, DB1011 thru DB1149, OM5131 thru OM14723,
DX1171 thru DX1969, DA1002 thru DA1004, and DY1008 thru DY1138)**

MA246707

SECTION V SCHEMATICS AND DIAGRAMS

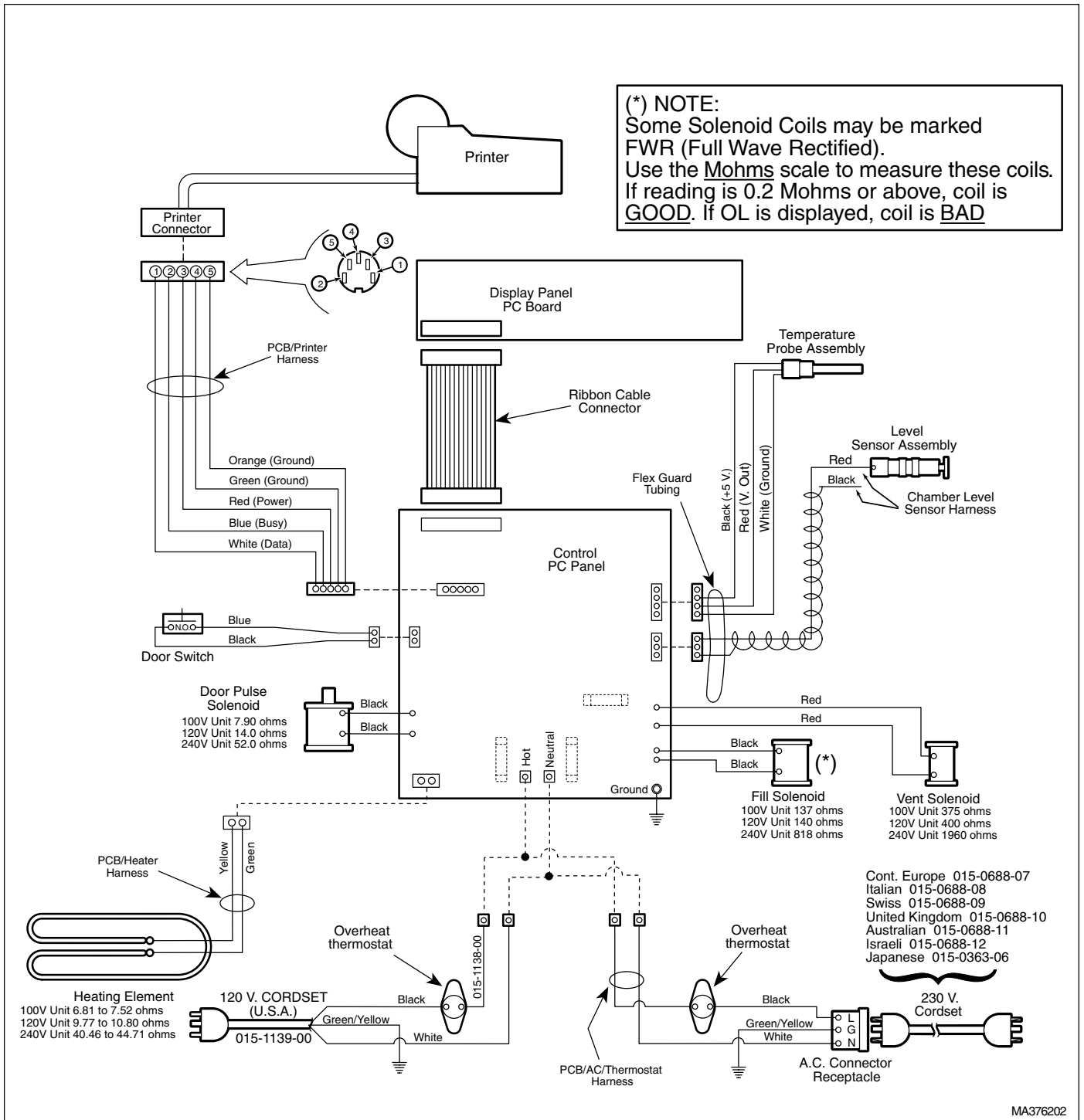
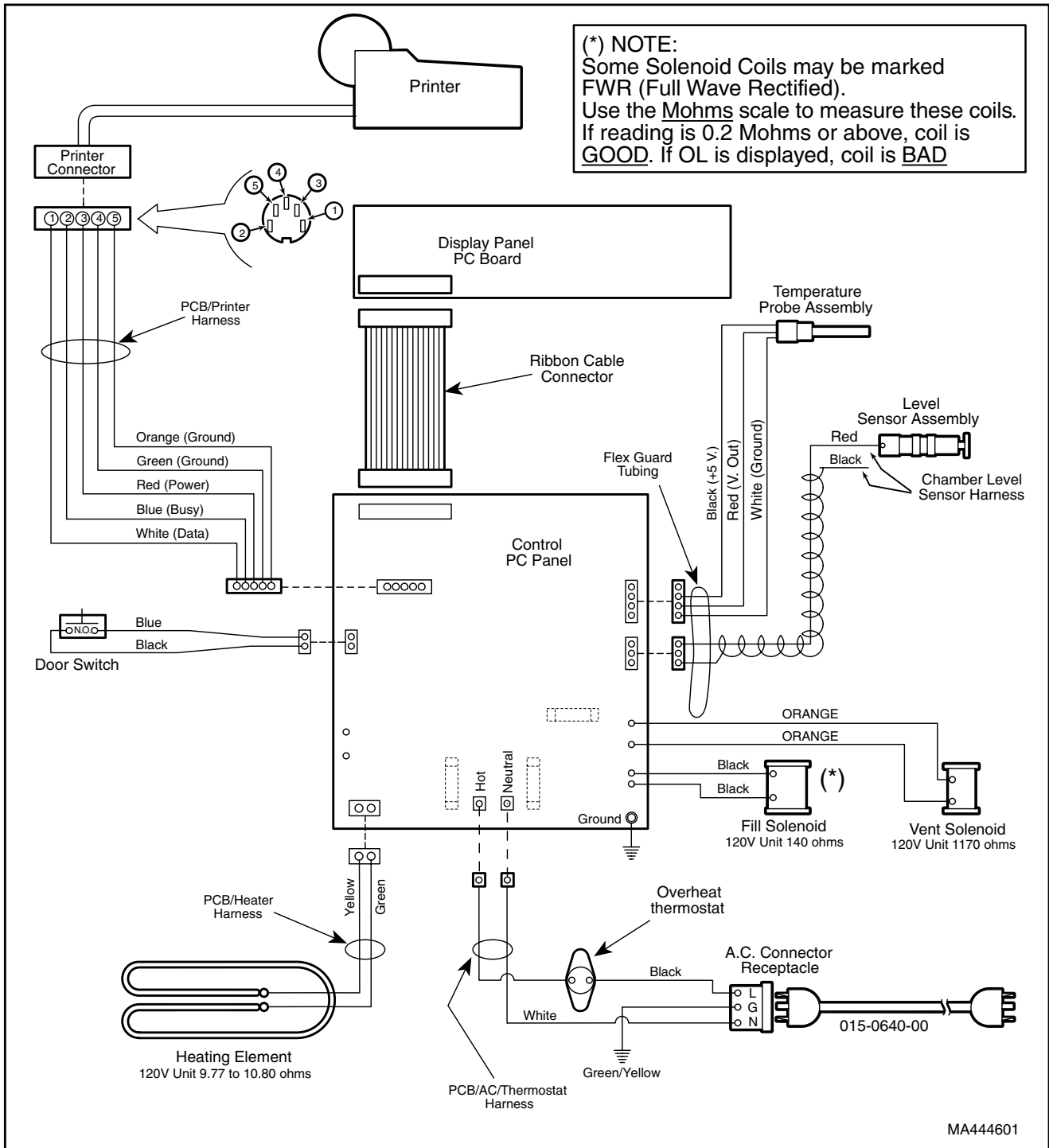

Figure 5-1 (Sheet 3 of 3) M9 Wiring Diagram
 (Applies To Serial Numbers CZ4591 thru Present, DA1005 thru Present, DB1150 thru Present, DX1970 thru Present, DY1139 thru Present, FD1000 thru Present, and OM14724 thru Present)

SECTION V SCHEMATICS AND DIAGRAMS



**Figure 5-2 (Sheet 1 of 2) M9D Wiring Diagram
(Applies To Serial Numbers FF1000 thru FF1054, FG1000 thru FG1137)**

MA444601

SECTION V SCHEMATICS AND DIAGRAMS

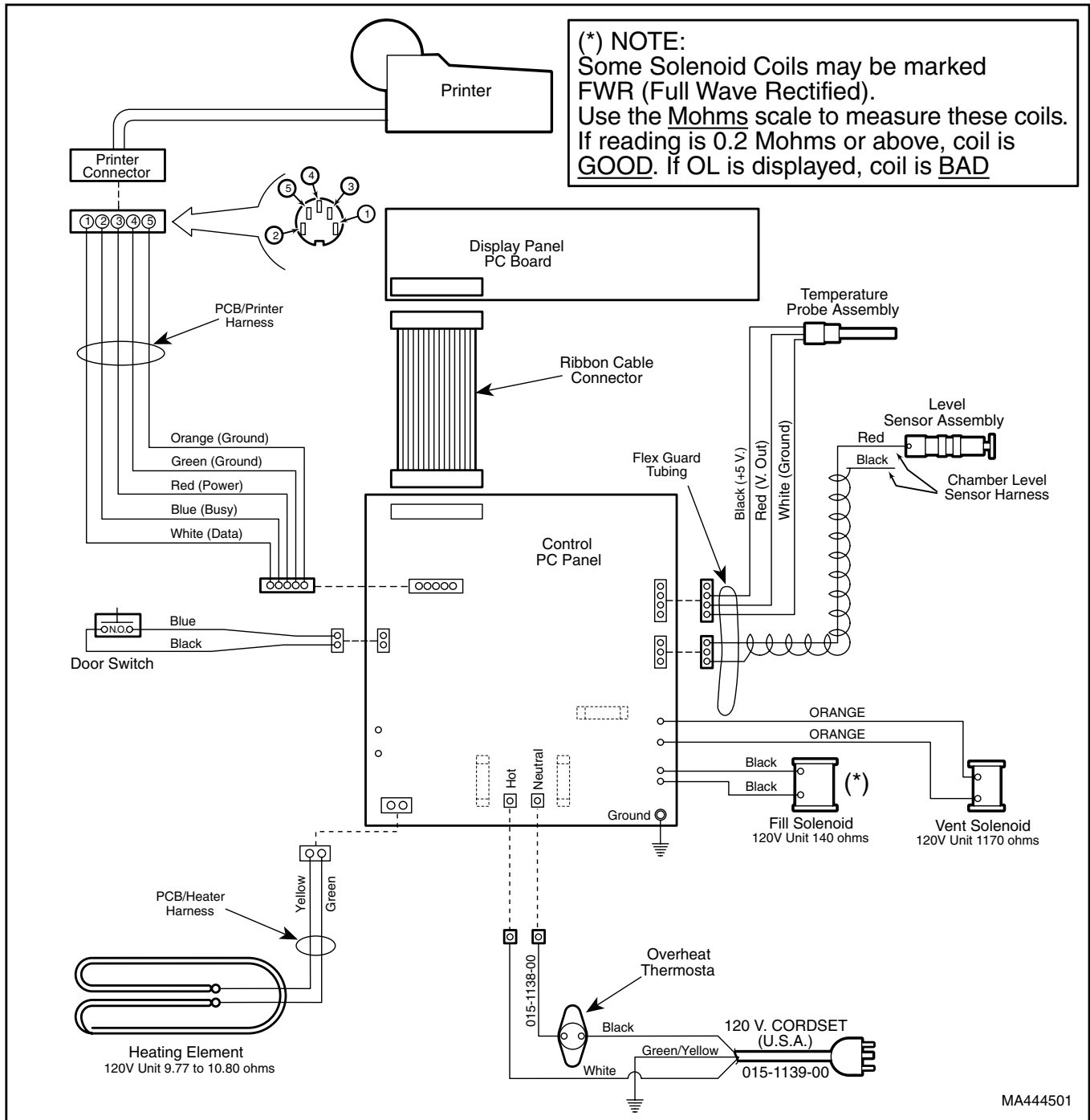

**Figure 5-2 (Sheet 2 of 2) M9D Wiring Diagram
(Applies To Serial Numbers FF1055 thru Present and FG1138 thru Present)**

SECTION V SCHEMATICS AND DIAGRAMS

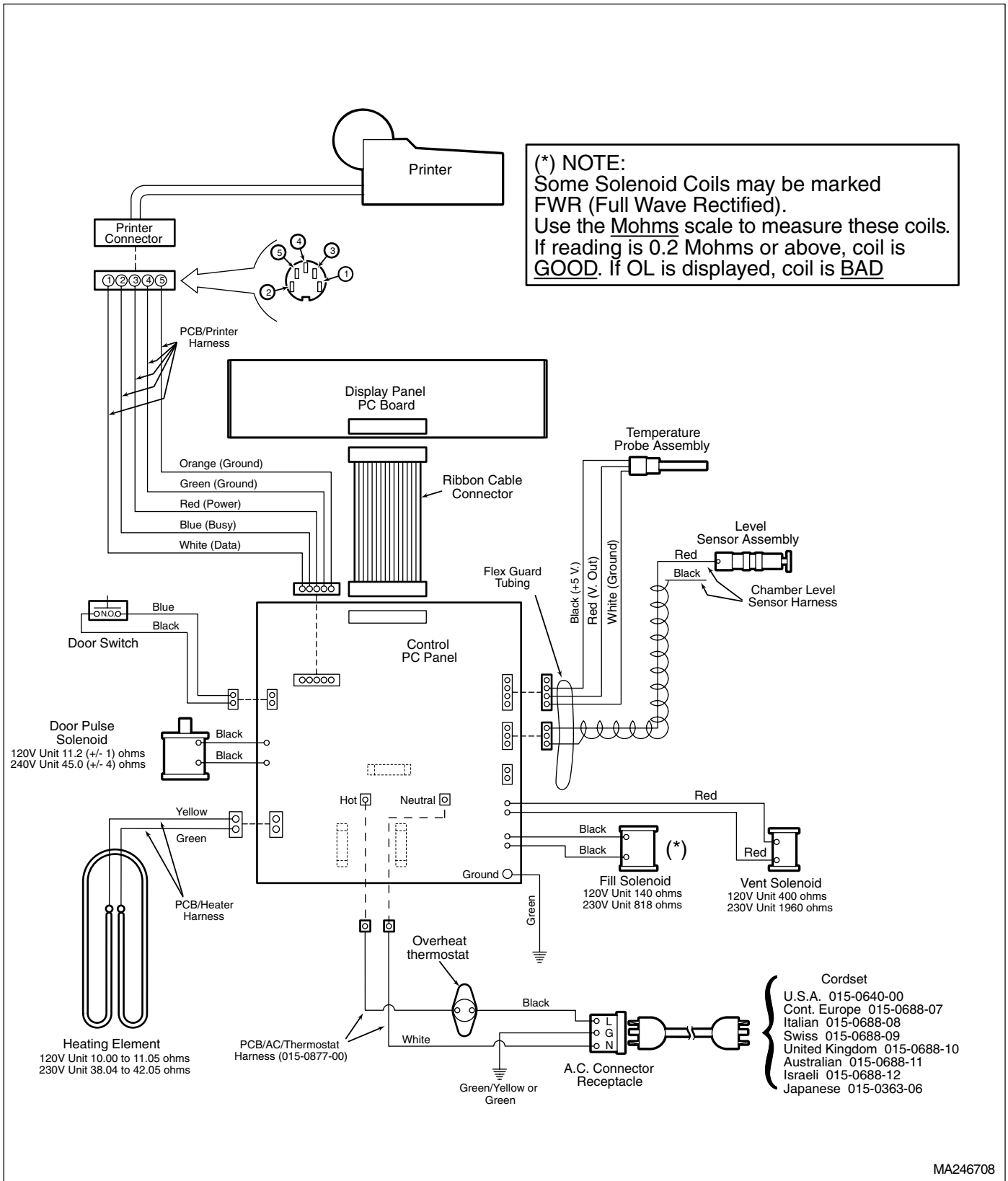

**Figure 5-3. (Sheet 1 of 3) M11 Wiring Diagram
(Applies to Units With Serial Numbers ES-1000 Thru ES-1346 And ET-1000 Thru ET1094)**

MA246708

SECTION V SCHEMATICS AND DIAGRAMS

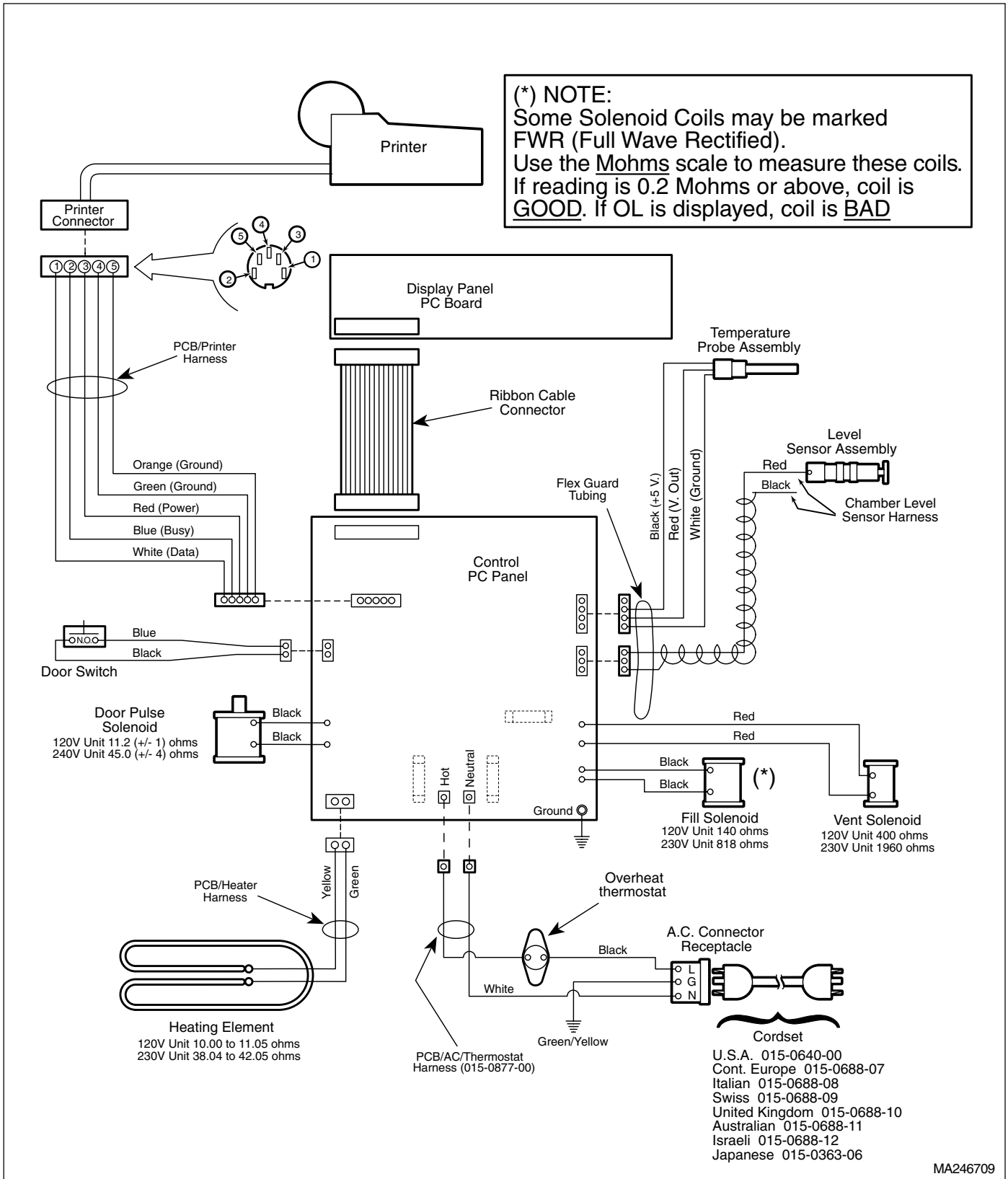

MA246709

**Figure 5-3. (Sheet 2 of 3) M11 Wiring Diagram
(Applies to Units With Serial Numbers ES1347 thru ES3020 and ET1095 thru ET3317)**

SECTION V SCHEMATICS AND DIAGRAMS

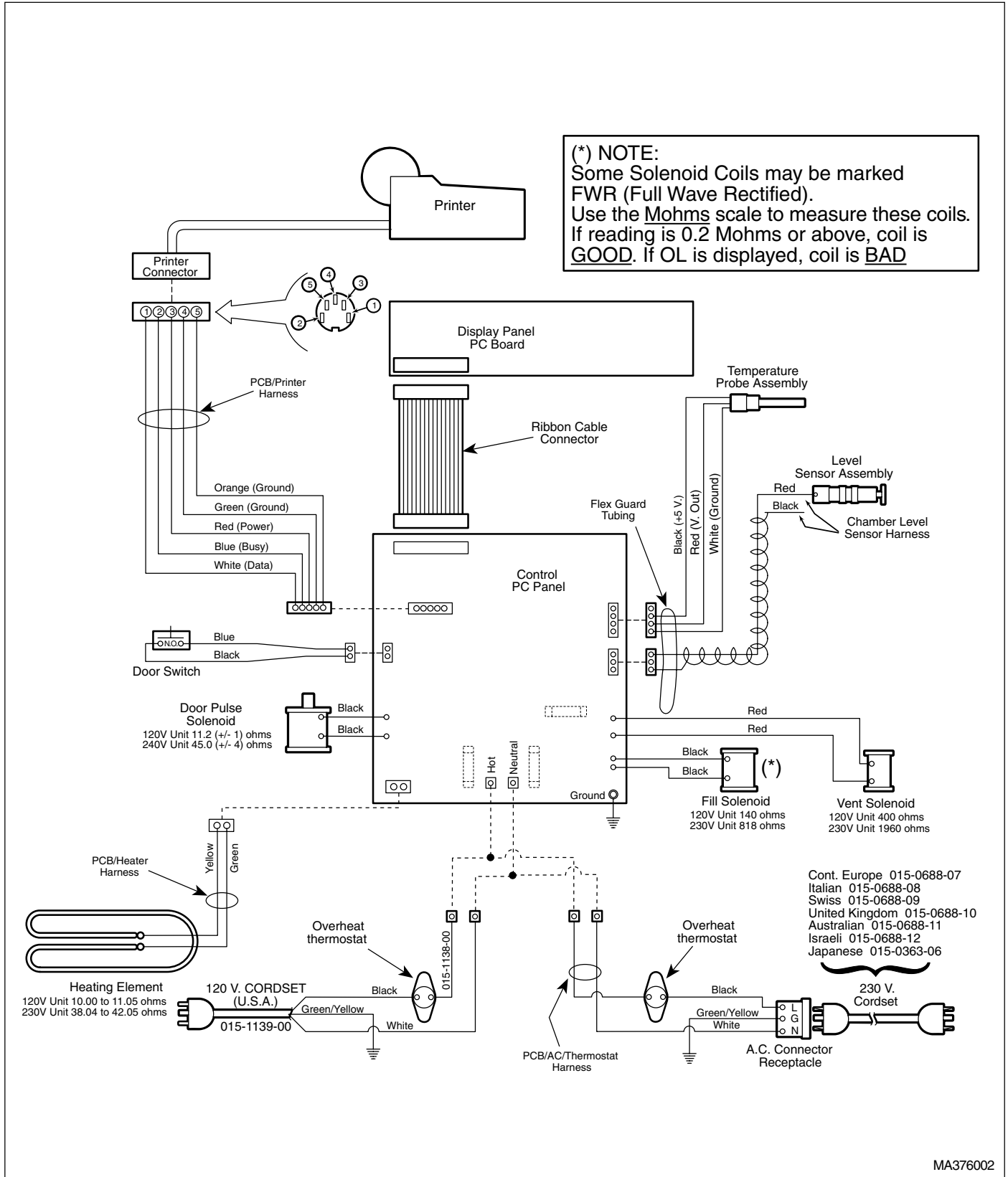

MA376002

**Figure 5-3. (Sheet 3 of 3) M11 Wiring Diagram
(Applies to Units With Serial Numbers ES3021, ET3318, FP1000, FR1000, and GB1000 Thru Present)**

SECTION V SCHEMATICS AND DIAGRAMS

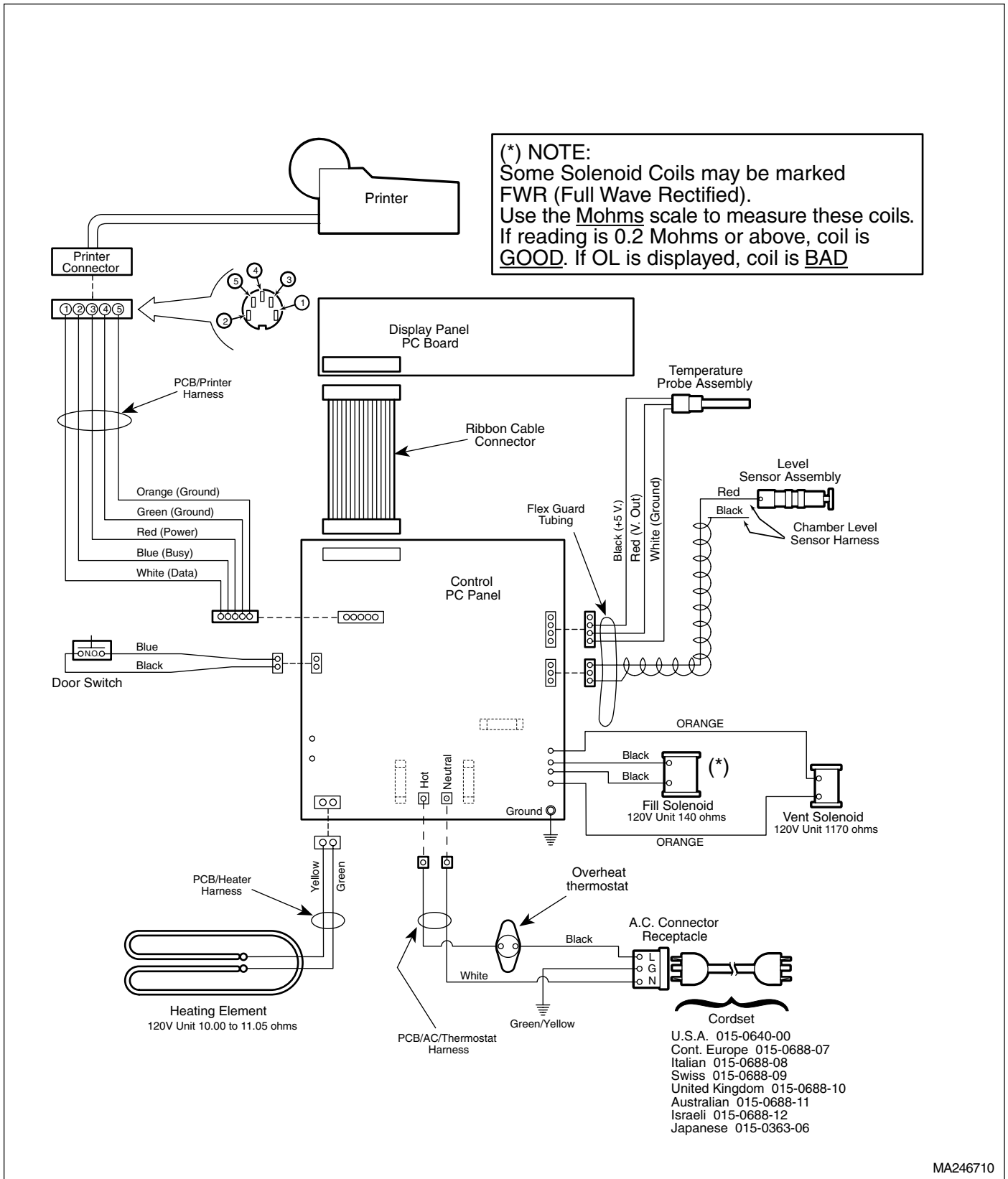

MA246710

**Figure 5-4. (Sheet 1 of 2) M11D Wiring Diagram
(Applies to Units With Serial Numbers GC1000 thru GC1018 and GD1000 Thru GD1015)**

SECTION V SCHEMATICS AND DIAGRAMS

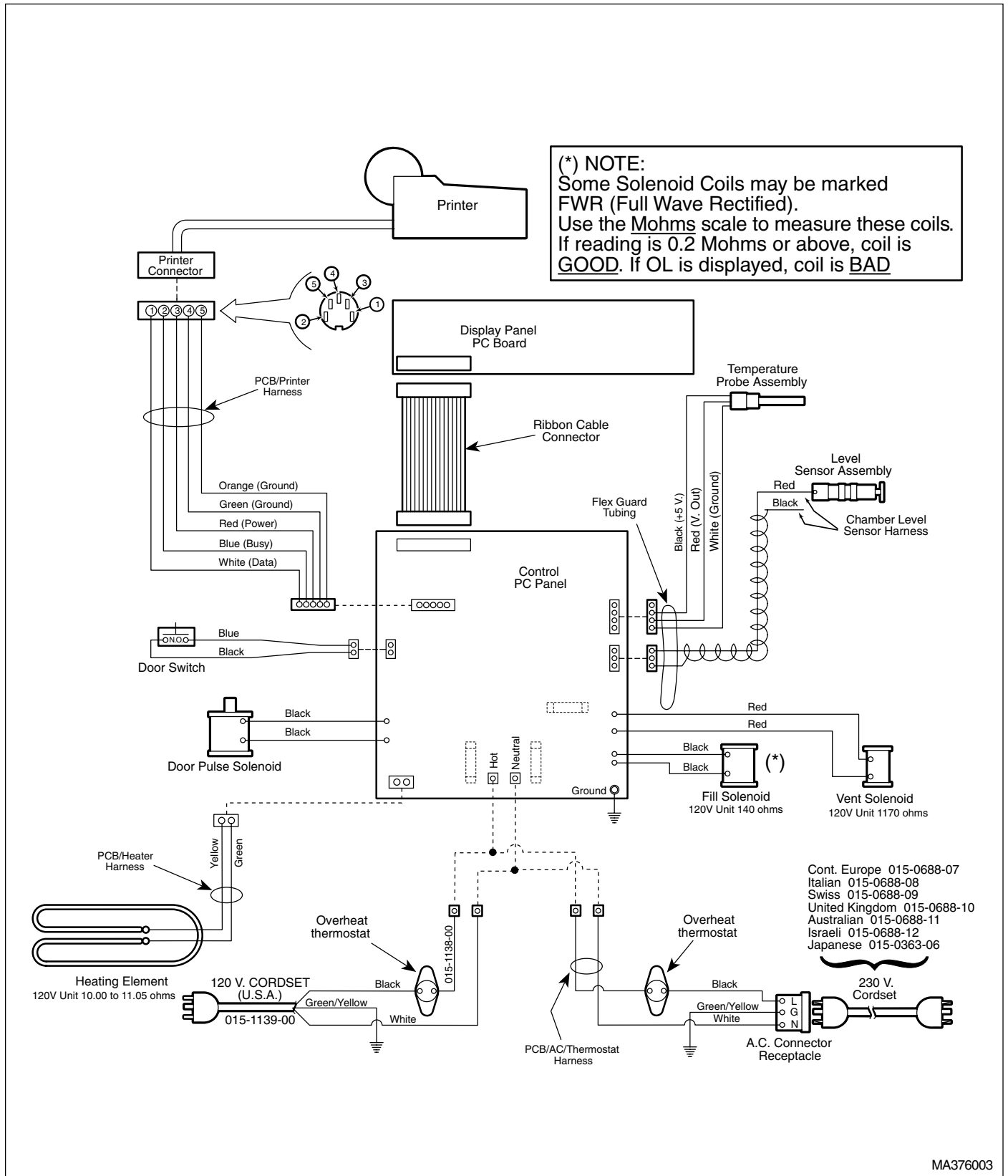

**Figure 5-4. (Sheet 2 of 2) M11D Wiring Diagram
(Applies to Units With Serial Numbers GC1019, and GD1016 Thru Present)**

5.2 Flow Diagram

Figure 5-5 illustrates the water, heated water, steam, and vented steam/water flow throughout the sterilizer during a cycle.

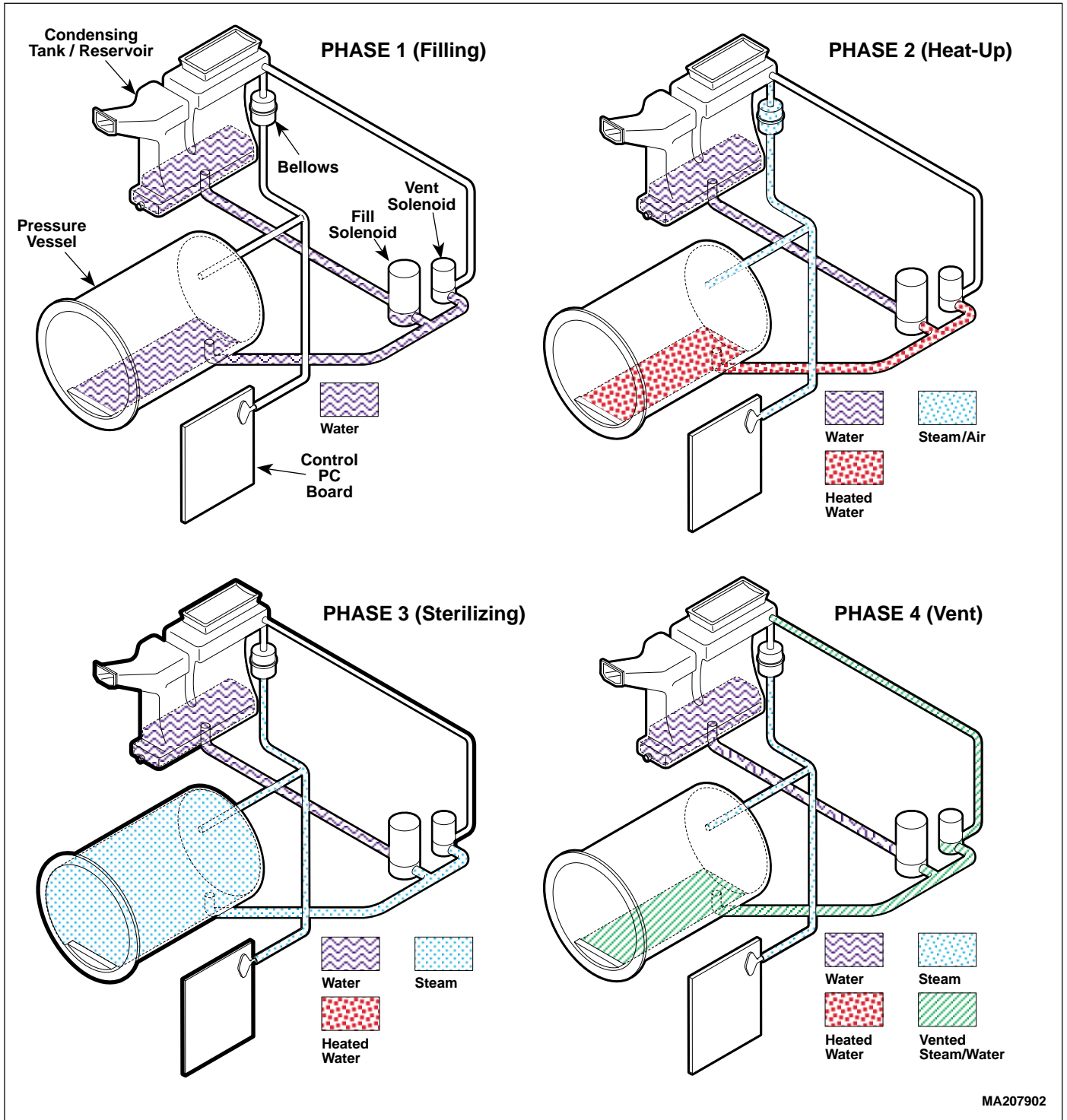

Figure 5-5. Flow Diagram

SECTION V SCHEMATICS AND DIAGRAMS

5.3 Pressure / Temperature Chart

Table 5-1 is a chart which lists what pressure should be present at particular temperature.

Table 5-1. Pressure / Temperature Chart

PSI	°C	°F	PSI	°C	°F
0	100.0	212.0	16	122.0	251.6
1	101.9	215.4	17	123.0	253.4
2	103.6	218.5	18	124.1	255.4
3	105.3	221.5	19	125.0	257.0
4	106.9	224.4	20	126.0	258.8
5	108.4	227.1	21	126.9	260.0
6	109.8	229.6	22	127.8	262.0
7	111.3	232.3	23	128.7	263.7
8	112.6	234.7	24	129.6	265.3
9	113.9	237.0	25	130.4	266.7
10	115.2	239.4	26	131.3	268.3
11	116.4	241.5	27	132.1	269.8
12	117.6	243.7	28	132.9	271.2
13	118.8	245.8	29	133.7	272.7
14	119.9	247.8	30	134.5	274.1
15	121.0	249.8			

Normal steam sterilizing range is 250°F to 270°F.

Figures in chart are for steam pressure only. The presence of any air in the autoclave invalidates temperature readings.

**SECTION VI
PARTS LIST**

6.1 Description of Bullets

If a component has a bullet [•] in the *Part No.* column and the *Description* column, it is a subcomponent of an assembly in the parts list.

6.2 Torque Specifications and Important Assembly Notes

Required torque specifications, measurements, and procedures will be noted on the parts illustrations. Adherence to these requirements is essential.

Attention!

The Parts Lists in this manual are separated as shown below .
Verify model number, then refer to appropriate pages.

M9 / M9D Pages 6-2 thru 6-16

M11 / M11D Pages 6-17 thru 6-31

M9 Component / Page Cross-Reference

SECTION VI PARTS LIST M9 / M9D

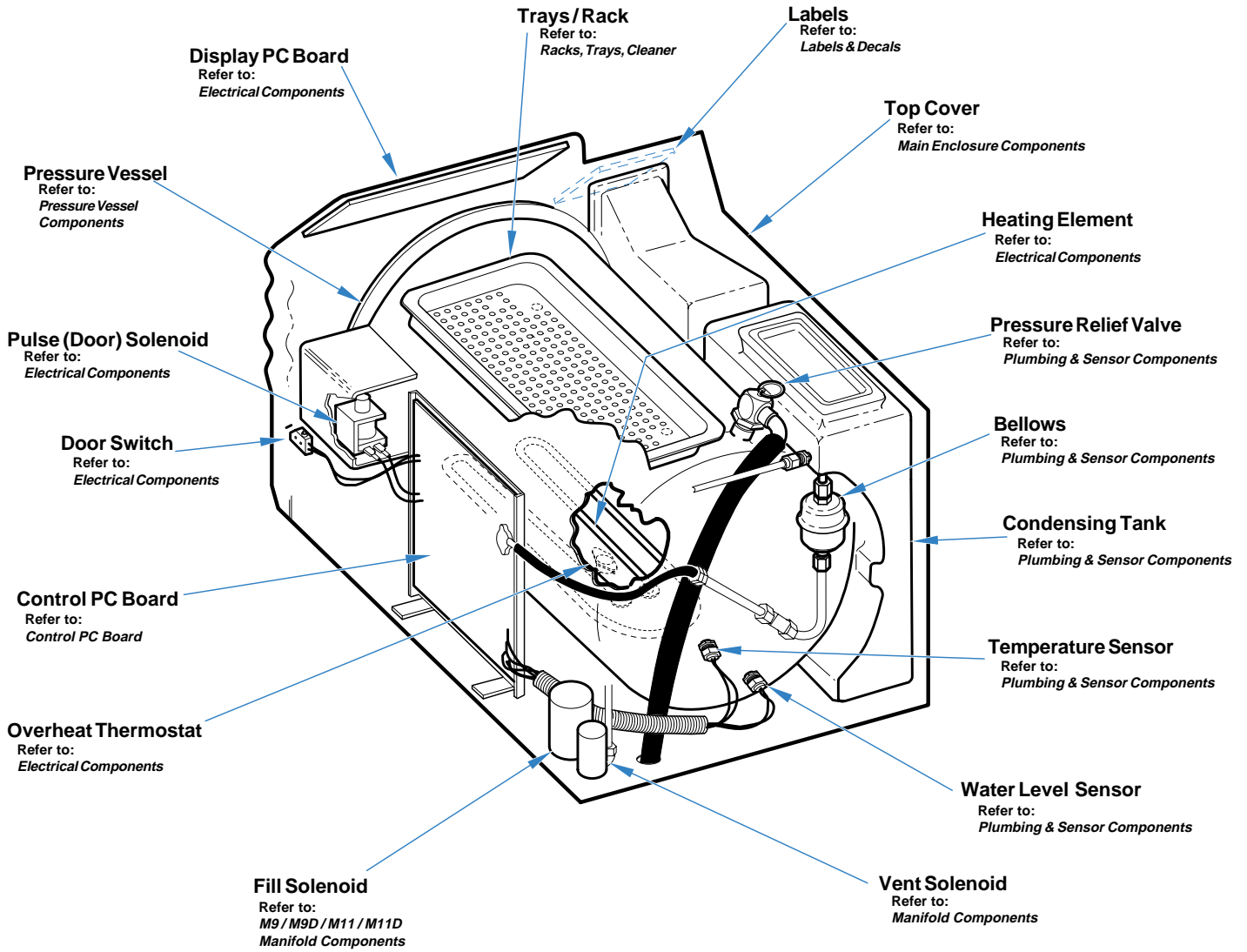

MA6007001

Item	Model No.	Description	Page	Item	Model No.	Description	Page
M9-001		Ritter M9 Ultraclave (115 VAC) [serial number prefix "OM"].....	6-2	M9-006		Ritter M9 Ultraclave (100VAC) [serial number prefix "DA"].....	6-2
M9-002		Ritter M9 Ultraclave (230VAC) [serial number prefix "DY"].....	6-2	M9-007		EMS M9 Ultraclave (230 VAC) [serial number prefix "FD"].....	6-2
M9-003		Midmark M9 Ultraclave (115 VAC) [serial number prefix "CZ"].....	6-2	M9-008		Dabi Atlante M9 Ultraclave (115 VAC) [serial number prefix "FK"].....	6-2
M9-004		Midmark M9 Ultraclave (230 VAC) [serial number prefix "DX"].....	6-2	M9-009		Dabi Atlante M9 Ultraclave (230 VAC) [serial number prefix "FL"].....	6-2
M9-005		Ritter M9 Ultraclave (100 VAC) [serial number prefix "DB"].....	6-2	M9-010		Polish M9 Ultraclave (230 VAC) [serial number prefix "LA"].....	6-2

Always Specify Model & Serial Number

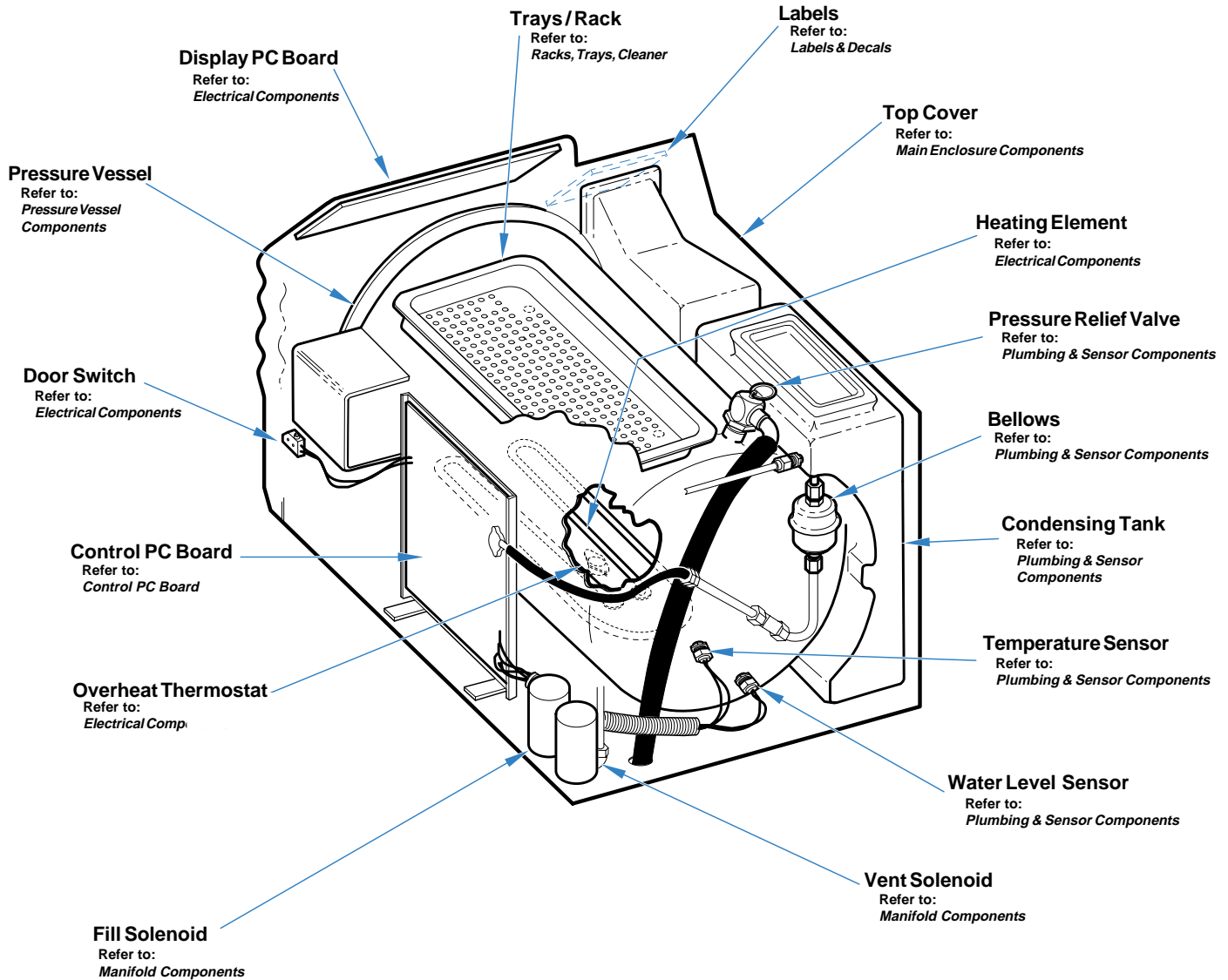

MA600800i

Item	Model No.	Description	Page	Item	Model No.	Description	Page
	M9D-001	Ritter M9D Ultraclave (115 VAC) [serial number prefix "FF"].....	6-3		M9D-002	Midmark M9D Ultraclave (115 VAC) [serial number Prefix "FG"].....	6-3
Always Specify Model & Serial Number							

Main Enclosure Components

SECTION VI PARTS LIST M9 / M9D

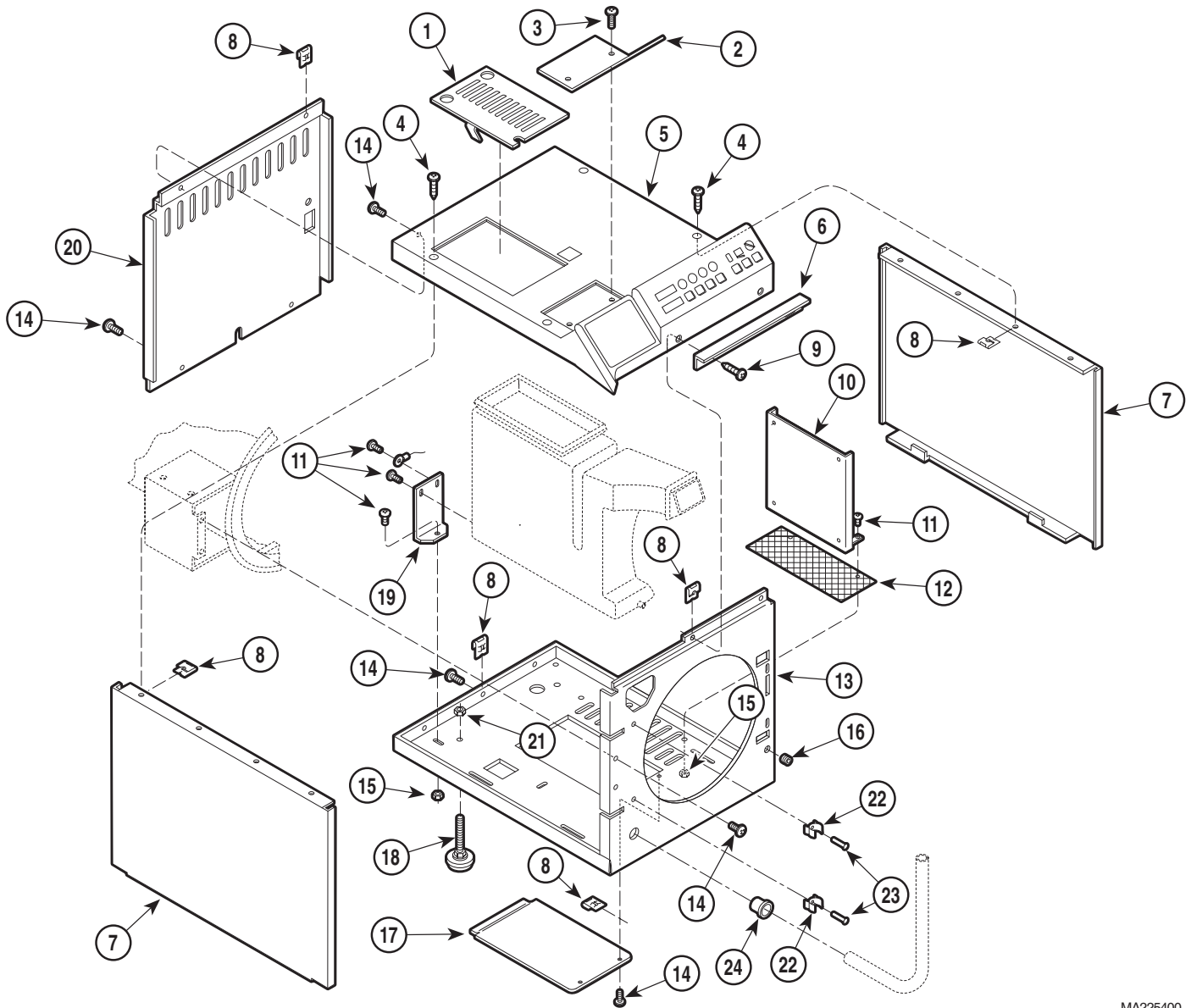

MA225400

**Used on units with Serial Numbers:
CZ1000 thru CZ1456 OM1000 thru OM3287**

Item	Part No.	Description	Qty.	Item	Part No.	Description	Qty.
1	030-0765-10	Top Inspection Cover	1	13	050-2346-00	Base	1
2	050-1775-10	Cover Plate - Printer	1	14	040-0010-18	Screw	11
3	040-0008-37	Screw	2	15	041-0010-04	Nut - w/Starwasher	3
4	040-0010-88	Screw	4	16	053-0394-01	Grommet (Early Units Only)	1
5	002-0356-00	Top Cover	1	17	050-4326-01	Base Inspection Cover	1
6	050-2034-00	Top Cover Steam Block	1	18	016-0404-00	Leveler Foot	4
7	050-1767-10	Side Panel	2	19	050-1778-00	Bracket	1
8	H352623	Tinnerman Clip	12	20	050-1766-10	Back Panel	1
9	040-0010-95	Screw	2	21	041-0312-05	Lock Nut	4
10	050-1777-00	Control PCB Bracket	1	22	053-0388-01	Hose Clip	2
11	040-0010-75	Screw	5	23	042-0010-11	Pop Rivet	2
12	016-0428-01	Screen	1	24	053-0068-11	Strain Relief Bushing	1

Always Specify Model & Serial Number

Main Enclosure Components

SECTION VI PARTS LIST M9 / M9D

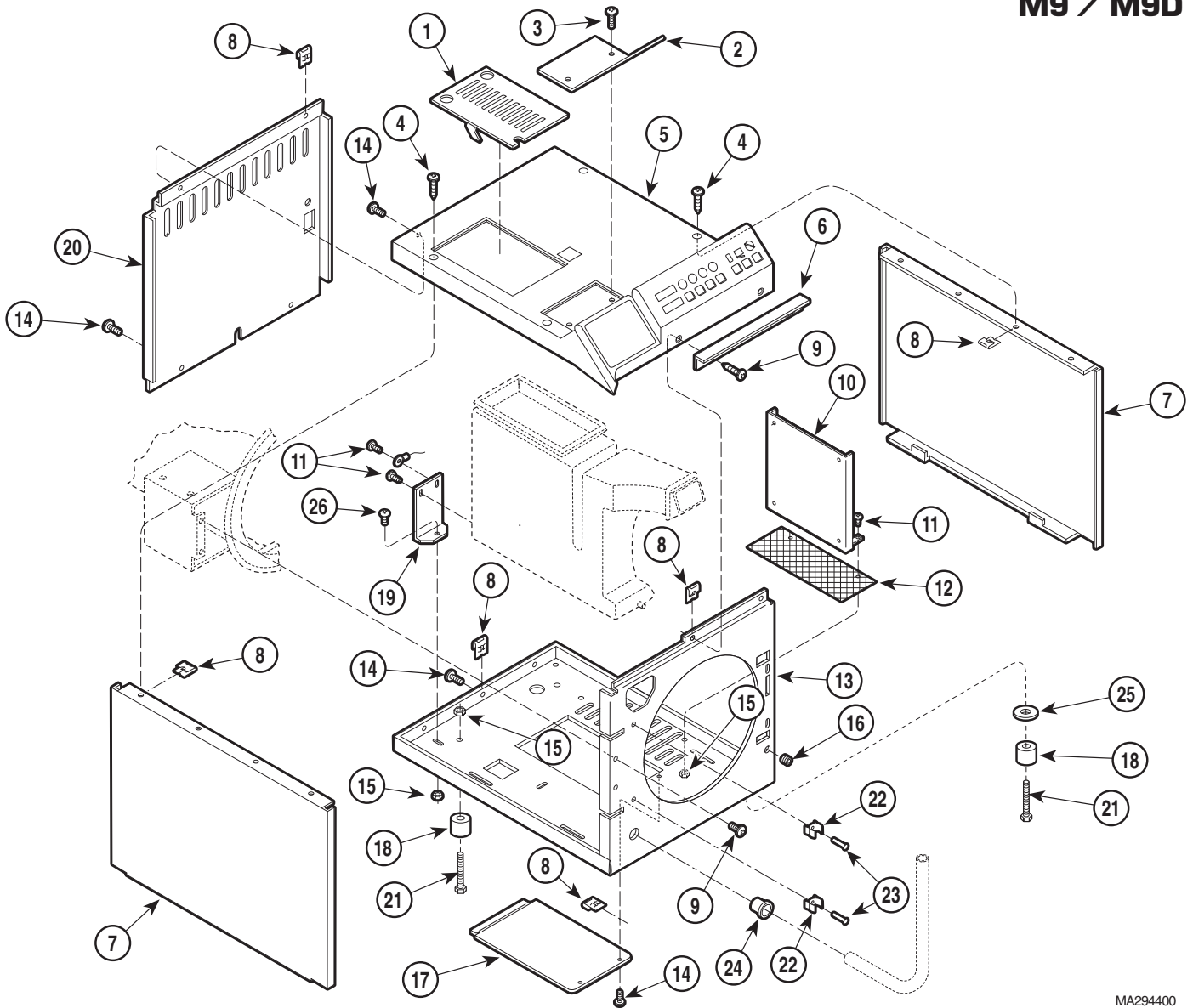

MA294400

Used on units with Serial Numbers:

CZ1457 thru CZ2753
DY1000 thru DY1149

DA1000 thru DA1004
FD1000 thru FD1099

DB1000 thru DB1149
OM3288 thru OM10596

DX1000 thru DX2131

Item	Part No.	Description	Qty.	Item	Part No.	Description	Qty.
1	030-0765-10	Top Inspection Cover	1	14	040-0010-18	Screw	7
2	050-1775-10	Cover Plate - Printer	1	15	041-0010-04	Nut - w/Starwasher	3
3	040-0008-50	Screw	2	16	053-0394-01	Grommet (Early Units Only)	1
4	040-0010-88	Screw	4	17	050-4326-01	Base Inspection Cover	1
5	002-0356-00	Top Cover (Domestic - English)	1	18	016-0523-00	Leveler Foot	4
	002-0356-01	Top Cover (Metric - English)	1	19	050-1778-00	Bracket	1
6	050-2034-00	Top Cover Steam Block	1	20	050-1766-10	Back Panel	1
7	050-1767-10	Side Panel	2	21	040-0010-43	Screw	4
8	H352623	Tinnerman Clip	13	22	053-0388-01	Hose Clip	2
9	040-0010-95	Screw	6	23	042-0010-11	Pop Rivet	2
10	050-1777-00	Control PCB Bracket	1	24	053-0068-11	Strain Relief Bushing	1
11	040-0010-75	Screw	3	25	045-0001-00	Washer	4
12	016-0428-01	Screen	1	26	040-0010-74	Screw	2
13	050-2518-00	Base	1				

Always Specify Model & Serial Number

Main Enclosure Components

SECTION VI PARTS LIST M9 / M9D

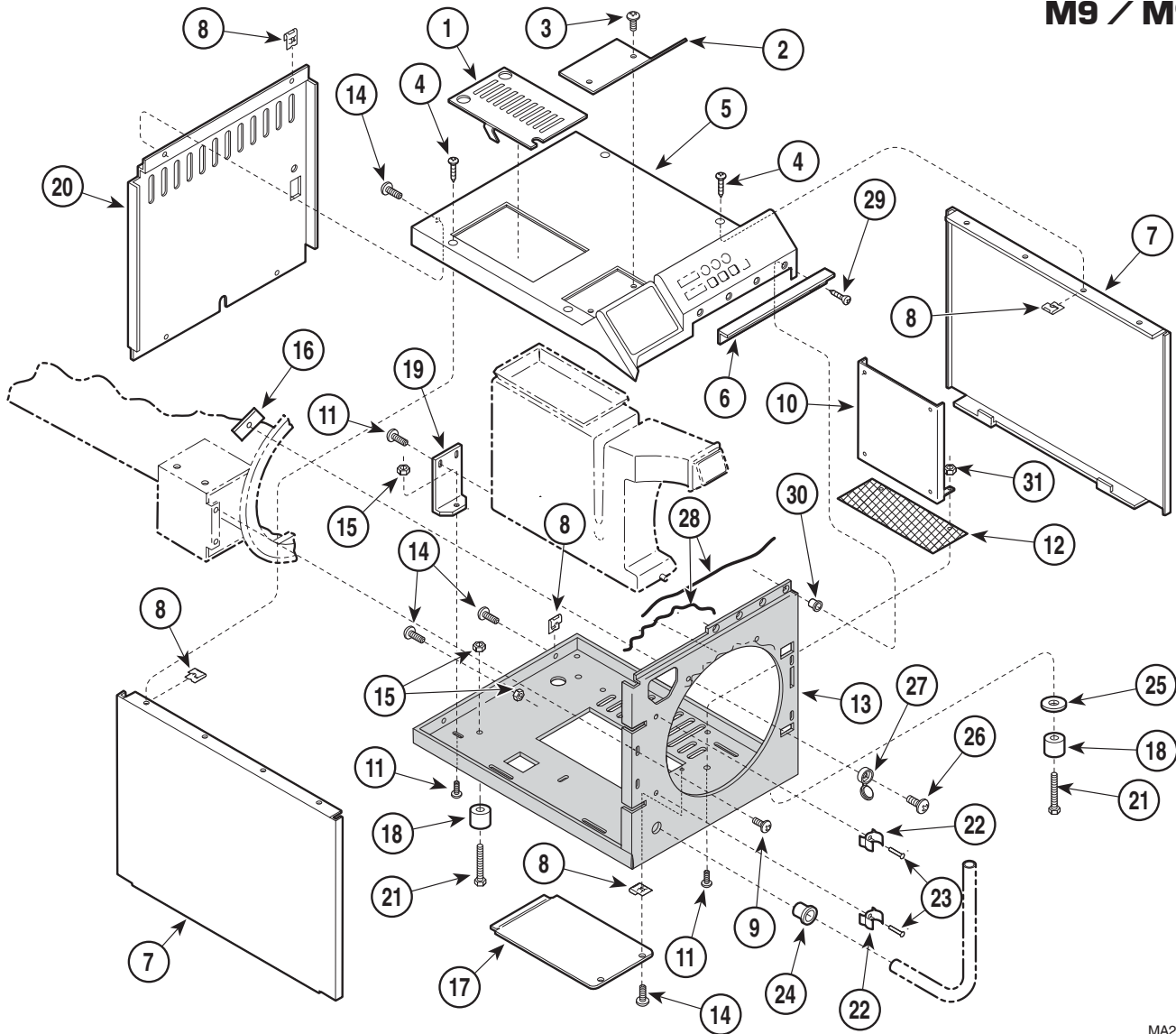

MA2944012

Used on units with Serial Numbers:

CZ2754 thru CZ4530
FD1100 thru FD1499
FL1000 thru FL1474

DB1150 thru DB1237
FF1000 thru FF1039
OM10597 thru OM14666

DX2132 thru DX2588
FG1000 thru FG1127

DY1150 thru DY1178
FK1000 thru FK1749

Item	Part No.	Description	Qty.	Item	Part No.	Description	Qty.
1	030-1117-00	Top Inspection Cover	1	16	050-4750-00	Flange Clamp	2
2	050-1775-00	Cover Plate - Printer	1	17	050-4326-01	Base Inspection Cover	1
3	040-0008-50	Screw	2	18	002-0963-00	Leveler Foot	4
4	040-0010-88	Screw	4	19	050-1778-00	Bracket	1
5	002-0356-00	Top Cover (Domestic - English)	1	20	050-3524-00	Back Panel	1
	002-0356-01	Top Cover (Metric - English)	1	21	040-0010-44	Screw	4
	002-0356-02	Top Cover (Metric - French)	1	22	053-0388-01	Hose Clip	2
6	050-2034-00	Top Cover Steam Block	1	23	042-0010-11	Pop Rivet	2
7	050-1767-00	Side Panel	2	24	053-0068-11	Strain Relief Bushing	1
8	H352623	Tinnerman Clip	10	25	045-0001-00	Washer	4
9	040-0010-95	Screw	4	26	040-0010-124	Screw	2
10	050-3996-00	Control PCB Bracket	1	27	053-0723-00	Screw Cover	2
11	040-0010-75	Screw	3	28	042-0021-00	Adhesive	AR
12	016-0428-04	Screen	1	29	040-0010-113	Screw	2
13	050-3605-00	Base	1	30	042-0045-01	Nutsert	2
14	040-0010-125	Screw	7	31	041-0010-04	Nut	2
15	041-0010-02	Nut	6				

Always Specify Model & Serial Number

Main Enclosure Components

SECTION VI PARTS LIST M9 / M9D

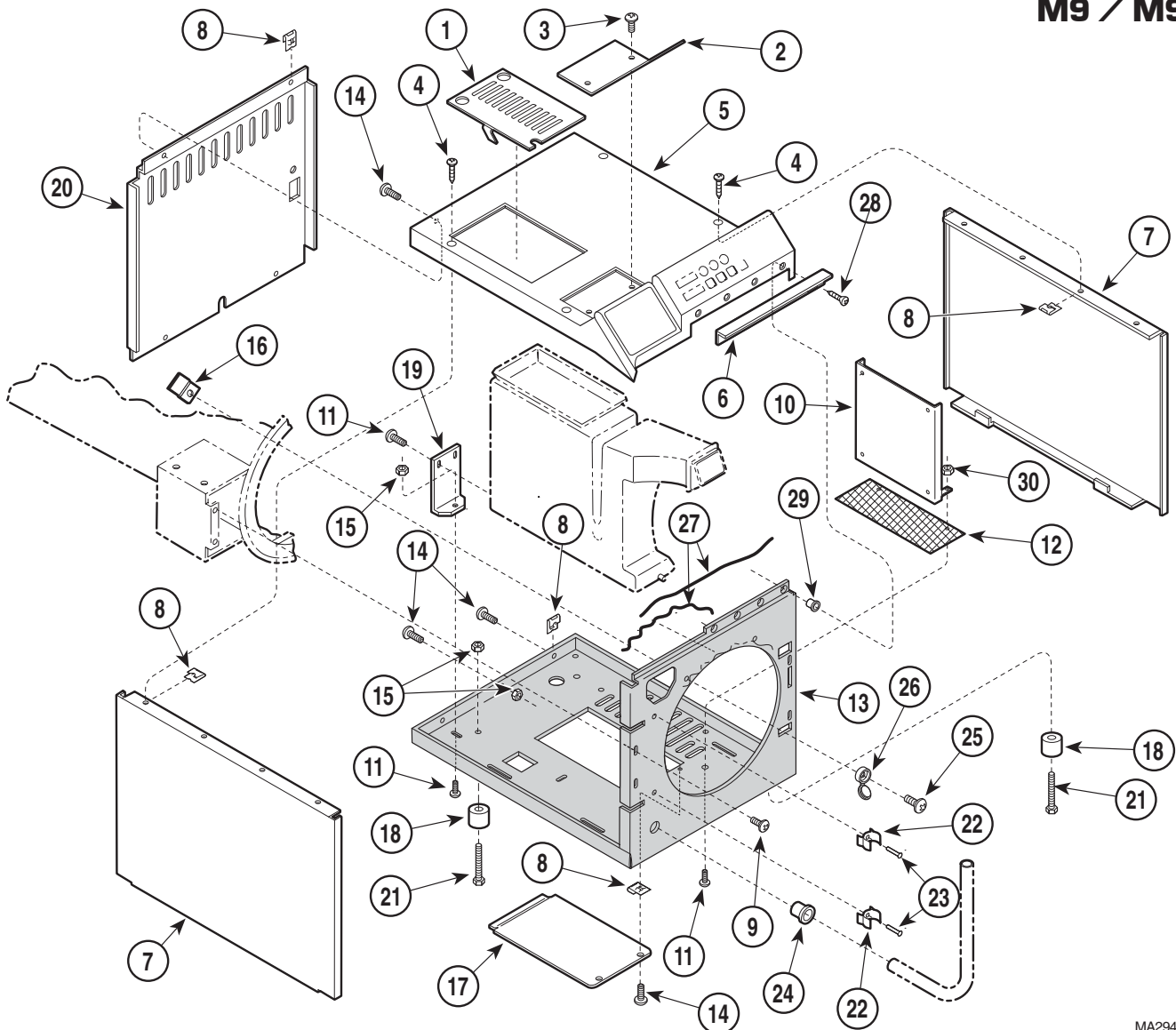

MA294404

Used on units with Serial Numbers:

**CZ4531, DA1005, DB1238, DX2589, DY1179, FD1500, FF1040, FG1128,
FK1750, FL1475, FX1000, FY1000, LA1000 and OM14667 - thru Present**

Item	Part No.	Description	Qty.	Item	Part No.	Description	Qty.
1	030-1117-00	Top Inspection Cover	1	16	050-4750-00	Flange Clamp	2
2	050-1775-00	Cover Plate - Printer	1	17	050-4326-00	Base Inspection Cover (1 hole)	1
3	040-0008-50	Screw	2		050-4326-01	Base Inspection Cover (3 holes)	1
4	040-0010-88	Screw	4	18	002-0963-00	Leveler Foot	4
5	002-0356-00	M9 Top Cover (Domestic - English)	1	19	050-1778-00	Bracket	1
	002-0356-01	M9 Top Cover (Metric - English)	1	20	050-3831-01	Back Panel (120 V.)	1
	002-0356-02	M9 Top Cover (Metric - French)	1		050-3831-00	Back Panel (100 V. & 230 V.)	1
	002-0520-00	M9D Top Cover	1	21	040-0010-44	Screw	4
6	050-2034-00	Top Cover Steam Block	1	22	053-0388-01	Hose Clip	2
7	050-1767-00	Side Panel	2	23	042-0010-11	Pop Rivet	2
8	H352623	Tinnerman Clip	10	24	053-0068-11	Strain Relief Bushing	1
9	040-0010-95	Screw	5	25	040-0010-124	Screw	2
10	050-3996-00	Control PCB Bracket	1	26	053-0723-00	Screw Cover	2
11	040-0010-75	Screw	3	27	042-0021-00	Adhesive	AR
12	016-0428-04	Screen	1	28	040-0010-113	Screw	2
13	050-4325-00	Base	1	29	042-0045-01	Nutsert	2
14	040-0010-125	Screw	6	30	041-0010-04	Nut	2
15	041-0010-02	Nut	5				

Always Specify Model & Serial Number

Plumbing & Sensor Components

SECTION VI PARTS LIST M9 / M9D

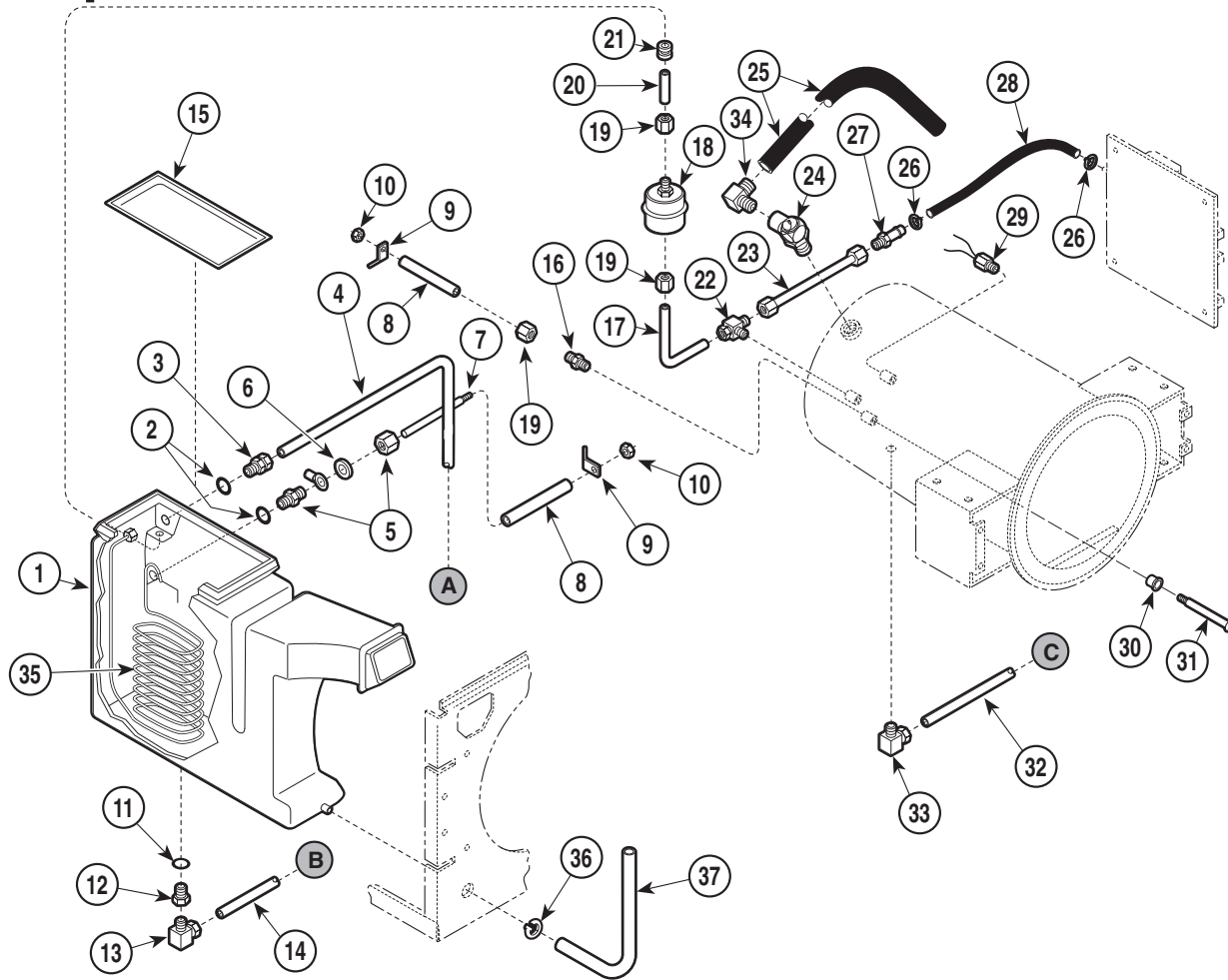

MA201910

Used on units with Serial Numbers: CZ1000 thru CZ1119 OM1000 thru OM1352

Item	Part No.	Description	Qty.	Item	Part No.	Description	Qty.
1	(N.L.A.)	Condensing Tank (Includes Item 15)	1	22	014-0202-00	Male Branch Tee	1
2	053-0392-00	O-ring	2	23	014-0207-00	PCB Pres. Sensor Tube (Refer to Kit [*])	1
3	014-0216-00	Bulkhead Union	1	24	002-0359-00	Pressure Relief Valve (35 P.S.I.) (Includes elbow, Item 36)	1
	014-0392-00	Compression Nut Only	AR	25	053-0403-01	Tube - Pressure Relief	1
4	014-0205-00	Tube	1	26	015-0013-05	High Temp Cable Tie (Refer to Kit [*])	4
5	014-0215-00	Union Drilled (Includes Sleeve)	1	27	014-0217-00	Compression Connector (Refer to Kit [*])	1
6	045-0001-56	Lockwasher	1	28	053-0404-01	Tube - PCB Connector (Refer to Kit [*]) .	1
7	057-0273-01	Level Sensor Rod	1	29	002-0357-00	Temperature Probe Assembly	1
8	053-0390-01	Level Sensor Tube(Refer to Kit [**])	1	30	053-0407-00	Bushing (Refer to Kit [**])	1
9	015-0595-00	Terminal (Refer to Kit [**])	2	31	030-0858-00	Level Sensor Assembly (Refer to Kit [**])	1
10	041-0006-02	Locknut (Refer to Kit [**])	2	32	014-0204-00	Tube	1
11	053-0393-00	O-ring	1	33	014-0184-01	Male 90° Elbow	1
12	014-0209-00	Bulkhead Couple	1	34	014-0258-00	Male Elbow	1
13	014-0184-01	Male Elbow	1	35	052-0173-00	Condensing Coil	1
14	014-0203-00	Tube	1	36	016-0450-00	Hose Clip	1
15		Condensing Tank Lid (Part of Item 1)	1	37	053-0391-01	Hose	1
16	014-0212-00	Connector (Refer to Kit [**])	1	[*]	002-0593-01	(*)Pressure Sensor Tube Kit (Includes #'s 19, 23, 26, 27, & 28)	1
17	014-0206-00	Tube	1	[**]	002-0358-00	Level Sensor Tube Kit (Includes Item 8, 9, 10, 16, 30, and 31))	2
18	002-0375-00	Bellows Assembly	1				
19	014-0392-00	Compression Nut (Refer to Kit [*])	2				
20	014-0208-00	Tube	1				
21	053-0394-01	Grommet	1				

N.L.A. Denotes "No Longer Available"
Always Specify Model & Serial Number

Plumbing & Sensor Components

SECTION VI PARTS LIST M9 / M9D

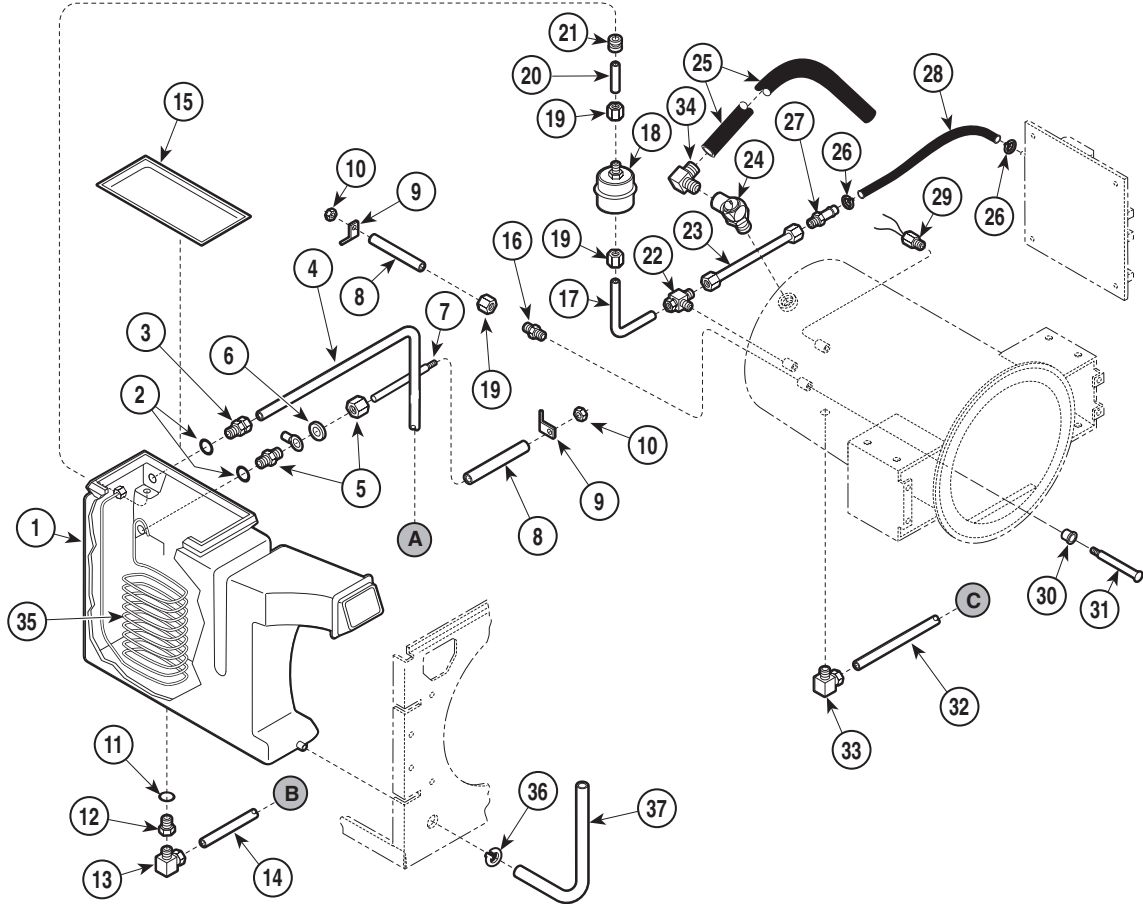

MA201910

Used on units with Serial Numbers:

**CZ1120 thru CZ1684
DX1000 thru DX1100**

DA1000 thru DA1001

**DB1000 (one unit)
OM1353 thru OM4864**

Item	Part No.	Description	Qty.	Item	Part No.	Description	Qty.
1	(N.L.A.)	Condensing Tank (Includes Item 15)	1	22	014-0202-00	Male Branch Tee	1
2	H98137	Gasket	2	23	014-0207-00	PCB Pres. Sensor Tube (Refer to Kit [*])	1
3	014-0216-00	Bulkhead Union	1	24	002-0359-00	Pressure Relief Valve (35 P.S.I.) (Includes Elbow, Item 36)	1
	014-0392-00	Compression Nut Only	AR	25	053-0403-02	Tube - Pressure Relief	1
4	014-0205-00	Tube	1	26	015-0013-05	High Temp Cable Tie (Refer to Kit [*])	4
5	014-0215-00	Union Drilled (Includes Sleeve)	1	27	014-0217-00	Compression Connector (Refer to Kit [*])	1
6	045-0001-56	Lockwasher	1	28	053-0404-01	Tube-PCB Connector (Refer to Kit [*]) ...	1
7	057-0273-01	Level Sensor Rod	1	29	002-0357-00	Temperature Probe Assembly	1
8	053-0390-01	Level Sensor Tube (Refer to Kit [**])	1	30	053-0407-00	Bushing (Refer to Kit [**])	1
9	015-0595-00	Terminal (Refer to Kit [**])	2	31	030-0858-00	Level Sensor Assembly (Refer to Kit [**])	1
10	041-0006-02	Locknut (Refer to Kit [**])	2	32	014-0204-00	Tube	1
11	053-0393-00	O-ring	1	33	014-0184-01	Male 90° Elbow	1
12	014-0209-00	Bulkhead Couple	1	34	014-0258-00	Male Elbow	1
13	014-0184-01	Male Elbow	1	35	052-0173-00	Condensing Coil	1
14	014-0203-00	Tube	1	36	016-0450-00	Hose Clip	1
15	(N.L.A.)	Condensing Tank Lid (Part of Item 1)	1	37	053-0391-01	Hose	1
16	014-0212-00	Connector (Refer to Kit [**])	1	[*]	002-0593-01	(*)Pressure Sensor Tube Kit (Includes #'s 19, 23, 26, 27, & 28)	1
17	014-0206-00	Tube	1	[**]	002-0358-00	Lever Sensor Tube Kit (Includes Item 8, 9, 10, 16, 30, and 31)	2
18	002-0375-00	Bellows Assembly	1				
19	014-0392-00	Compression Nut (Refer to Kit [*])	2				
20	014-0208-00	Tube	1				
21	053-0394-01	Grommet	1				

N.L.A. Denotes "No Longer Available"
Always Specify Model & Serial Number

Plumbing & Sensor Components

SECTION VI PARTS LIST M9 / M9D

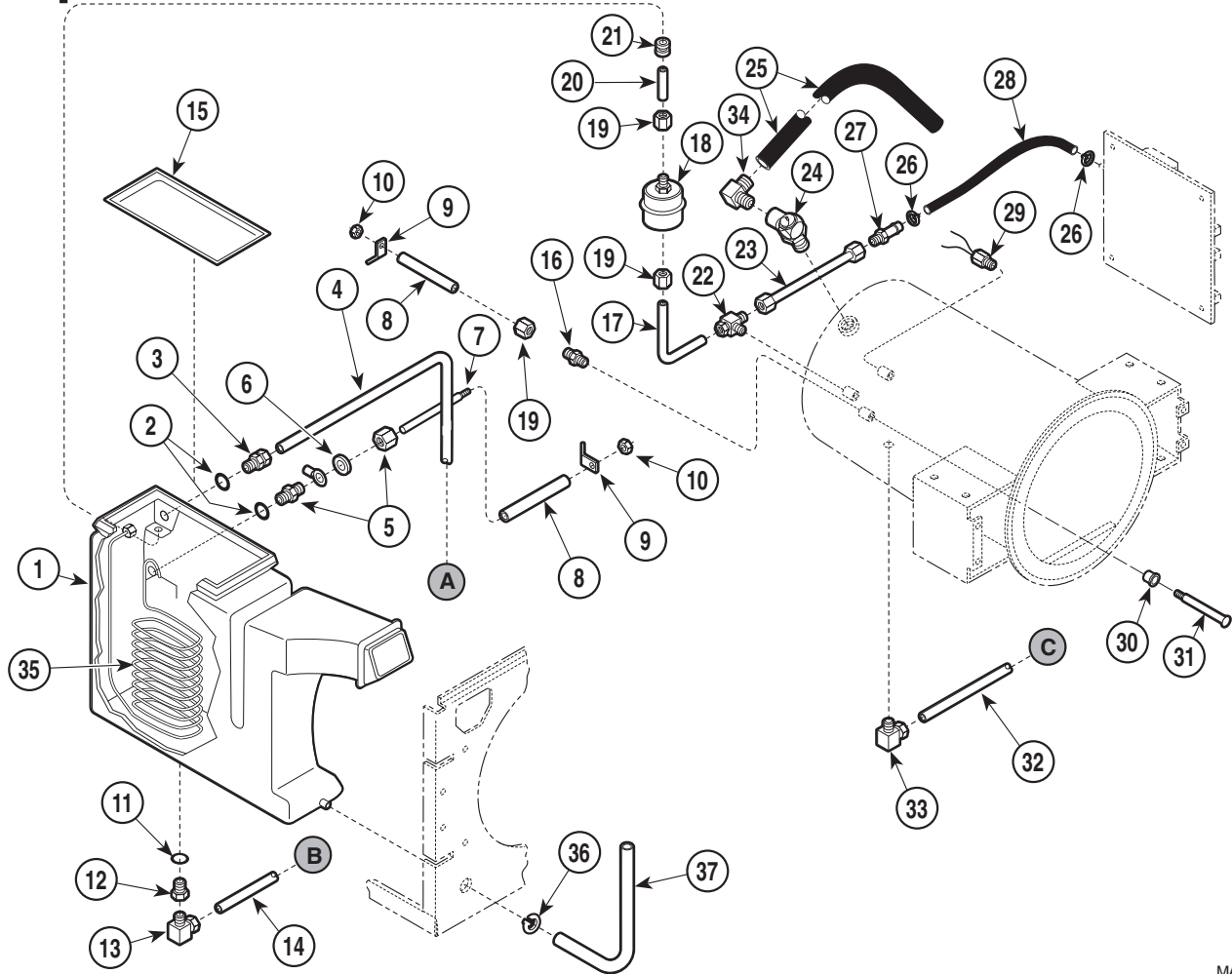

MA201910

Used on units with Serial Numbers:

DX1101 thru DX1170

DY1000 thru DY1007

OM4865 thru OM5130

Item	Part No.	Description	Qty.	Item	Part No.	Description	Qty.
1	(N.L.A.)	Condensing Tank (Includes Item 15)	1	22	014-0202-00	Male Branch Tee	1
2	H98137	Gasket	2	23	014-0207-00	PCB Pres. Sensor Tube (Refer to Kit [*])	1
3	014-0216-00	Bulkhead Union	1	24	002-0359-00	Pressure Relief Valve (35 P.S.I.) (Includes Elbow, Item 36)	1
	014-0392-00	Compression Nut Only	AR	25	053-0613-02	Tube - Pressure Relief	1
4	014-0205-00	Tube	1	26	015-0013-05	High Temp Cable Tie (Refer to Kit [*])	4
5	014-0215-00	Union Drilled (Includes Sleeve)	1	27	014-0217-00	Compression Connector (Refer to Kit [*])	1
6	045-0001-56	Lockwasher	1	28	053-0404-01	Tube-PCB Connector (Refer to Kit [*]) ...	1
7	057-0273-01	Lever Sensor Rod	1	29	002-0357-00	Temperature Probe Assembly	1
8	053-0390-01	Level Sensor Tube (Refer to Kit [**])	1	30	053-0407-00	Bushing (Refer to Kit [**])	1
9	015-0595-00	Terminal (Refer to Kit [**])	2	31	030-0858-00	Level Sensor Assembly (Refer to Kit [**])	1
10	041-0006-02	Locknut (Refer to Kit [**])	2	32	014-0204-00	Tube	1
11	053-0393-00	O-ring	1	33	014-0184-01	Male 90° Elbow	1
12	014-0209-00	Bulkhead Couple	1	34	014-0258-00	Male Elbow	1
13	014-0184-01	Male Elbow	1	35	052-0173-00	Condensing Coil	1
14	014-0203-00	Tube	1	36	016-0450-00	Hose Clip	1
15	(N.L.A.)	Condensing Tank Lid (Part of Item 1)	1	37	053-0391-01	Hose	1
16	014-0212-00	Connector (Refer to Kit [**])	1	[*]	002-0593-01	(*)Pressure Sensor Tube Kit (Includes #s 19, 23, 26, 27, & 28)	1
17	014-0206-00	Tube	1	[**]	002-0358-00	Lever Sensor Tube Kit (Includes Item 8, 9, 10, 16, 30, and 31)	2
18	002-0375-00	Bellows Assembly	1				
19	014-0392-00	Compression Nut (Refer to Kit [*])	2				
20	014-0208-00	Tube	1				
21	053-0394-01	Grommet	1				

N.L.A. Denotes "No Longer Available"
Always Specify Model & Serial Number

Plumbing & Sensor Components

SECTION VI PARTS LIST M9 / M9D

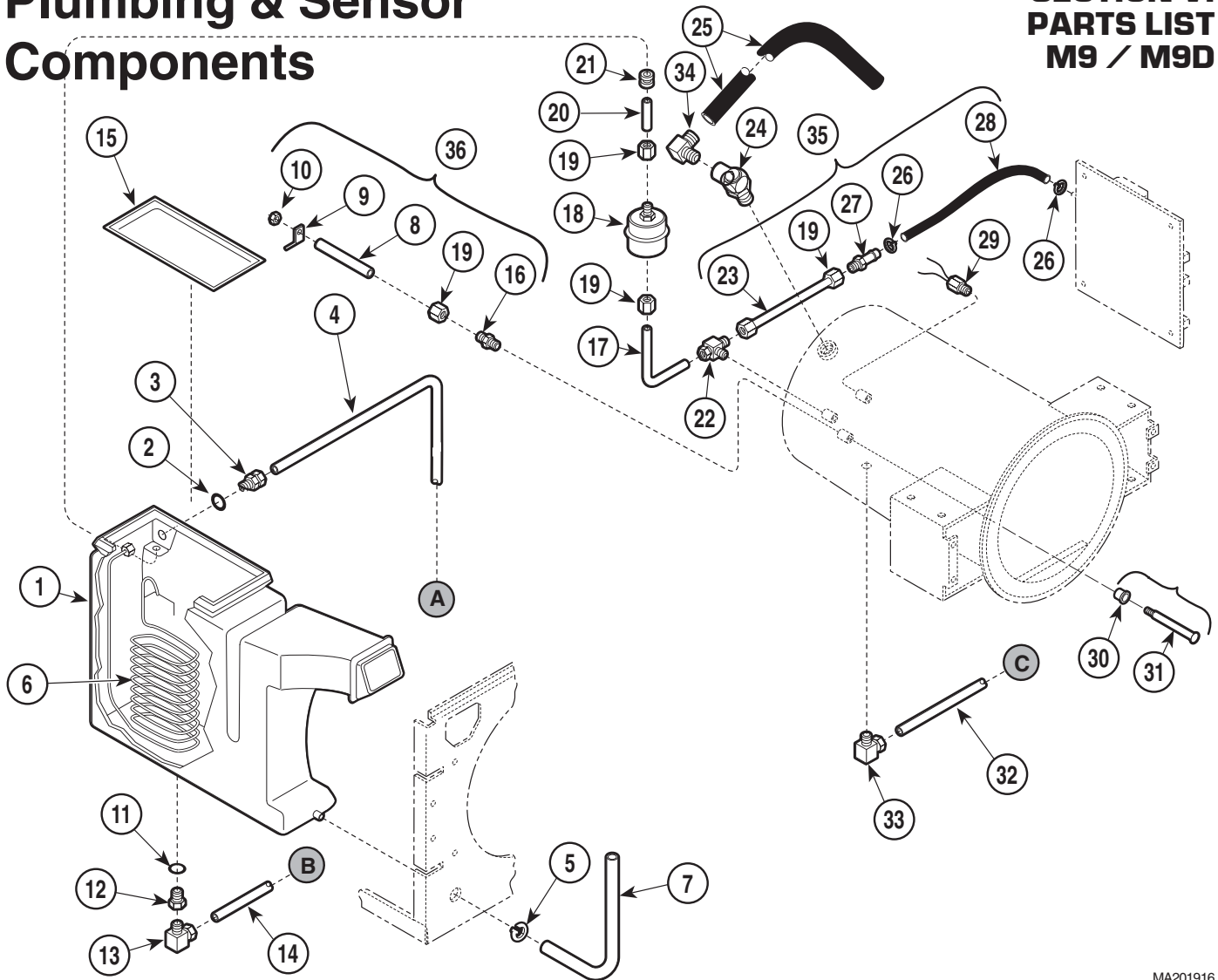

MA201916

Used on units with Serial Numbers:

CZ1685 thru CZ4334
DY1008 thru DY1176
FK1000 thru FK1699

DA1002 thru DA1004
FD1000 thru FD1399
FL1000 thru FL1474

DB1001 thru DB1237
FF1000 thru FF1034
OM5131 thru OM14524

DX1171 thru DX2555
FG1000 thru FG1112

Item	Part No.	Description	Qty.	Item	Part No.	Description	Qty.
1	053-0614-00	Condensing Tank (Includes Item 15)	1	20	014-0208-00	Tube	1
2	H98137	Gasket	1	21	053-0394-01	Grommet	1
3	014-0216-00	Bulkhead Union	1	22	014-0202-00	Male Branch Tee	1
	014-0392-00	Compression Nut Only	AR	23	014-0207-00	PCB Pres. Sensor Tube (Refer to Kit [*])	1
4	014-0205-00	Tube (M9)	1	24	002-0359-00	Pressure Relief Valve (35 P.S.I.) (include Elbow, Item 35)	1
	014-0277-00	Tube (M9D)	1	25	053-0613-01	Tube - Pressure Relief	1
5	016-0450-00	Hose Clip	1	26	015-0013-05	High Temp Cable Tie (Refer to Kit [*])	4
6	052-0173-00	Condensing Coil	1	27	014-0217-00	Compression Connector (Refer to Kit [*])	1
7	053-0391-01	Hose	1	28	053-0404-01	Tube-PCB Connector (Refer to Kit [*])	1
8	053-0390-01	Level Sensor Tube (Refer to Kit [**])	1	29	002-0357-00	Temperature Probe Assembly	1
9	015-0595-00	Terminal (Refer to Kit [**])	1	30	053-0407-00	Bushing (Refer to Kit [**])	1
10	041-0006-02	Locknut (Refer to Kit [**])	1	31	030-0858-00	Level Sensor Assembly (Refer to Kit [**])	1
11	053-0393-00	O-ring	1	32	014-0204-00	Tube	1
12	014-0209-00	Bulkhead Couple	1	33	014-0184-01	Male 90° Elbow	1
13	014-0184-01	Male Elbow	1	34	014-0258-00	Male Elbow	1
14	014-0203-00	Tube	1	35	002-0593-01	(*)Pressure Sensor Tube Kit (Includes #'s 19, 23, 26, 27, & 28)	1
15		Condensing Tank Lid (Part of Item 1)	1	36	002-0358-00	Lever Sensor Tube (Includes Item 8,9,10,16,30 and 31)	1
16	014-0212-00	Connector (Refer to Kit [**])	1				
17	014-0206-00	Tube	1				
18	002-0375-00	Bellows Assembly	1				
19	014-0392-00	Compression Nut (Refer to Kit [*])	2				

Always Specify Model & Serial Number

Plumbing & Sensor Components

SECTION VI PARTS LIST M9 / M9D

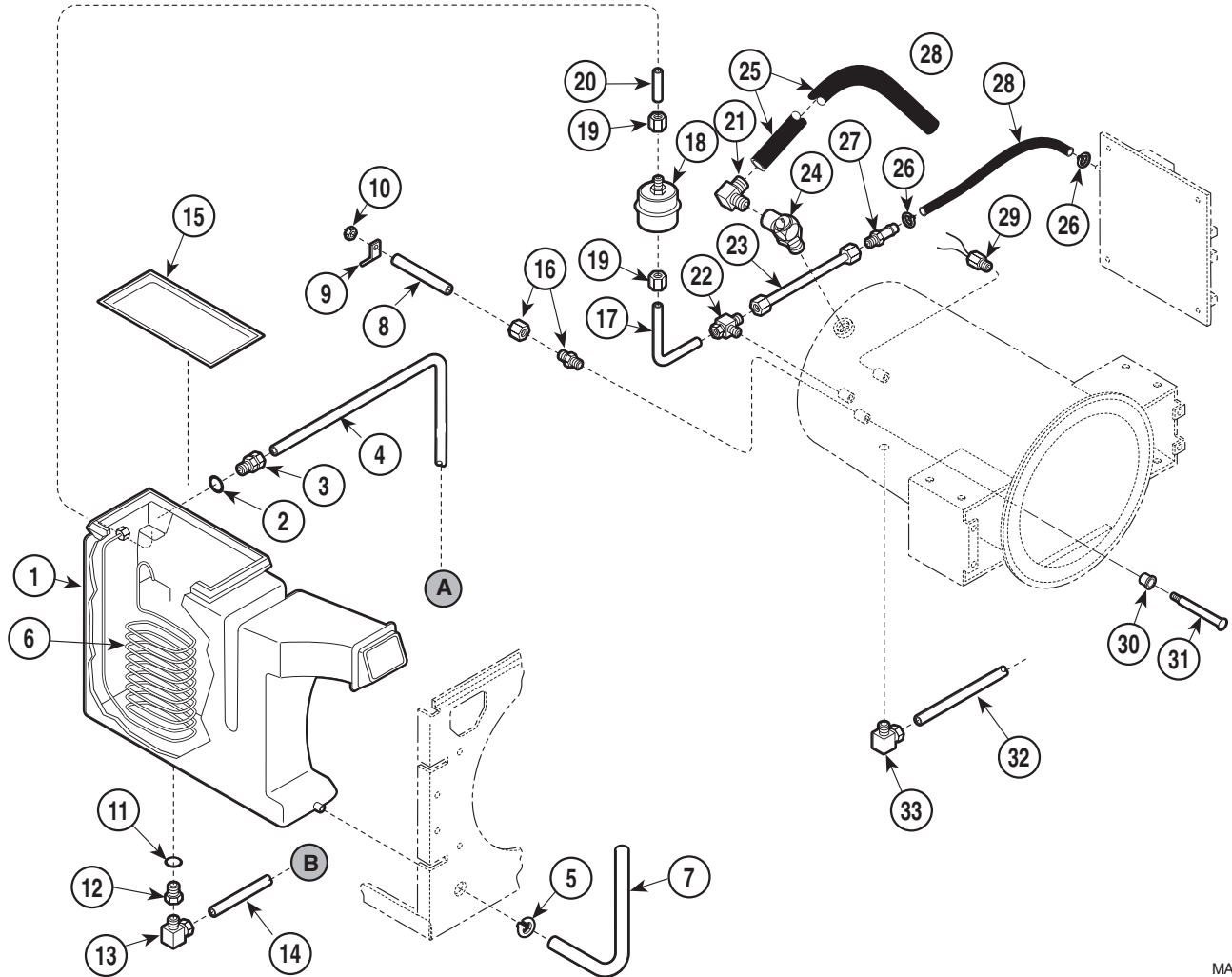

MA201912

Used on units with Serial Numbers:

CZ4335 thru CZ5944
FD1400 thru FD1954
FL1475 thru FL1843

DB1238 thru DB1262
FF1035 thru FF1177
OM14525 thru OM17468

DX2556 thru DX2883
FG1113 thru FG1290

DY1177 thru DY1178
FK1700 thru FK2279

Item	Part No.	Description	Qty.	Item	Part No.	Description	Qty.
1	053-0614-00	Condensing Tank (Includes Item 15)	1	18	002-0375-00	Bellows Assembly	1
2	H98137	Gasket	1	19	014-0392-00	Compression Nut (Refer to Kit [*])	2
3	014-0216-00	Bulkhead Union	1	20	014-0208-00	Tube	1
	014-0392-00	Compression Nut Only	AR	21	014-0258-00	Male Elbow	1
4	014-0205-00	Tube (M9)	1	22	014-0202-00	Male Branch Tee	1
	014-0277-00	Tube (M9D)	1	23	014-0207-00	PCB Pres. Sensor Tube (Refer to Kit [*])	1
5	016-0748-00	Hose Clip	1	24	002-0359-01	Pressure Relief Valve (40 P.S.I.) (Includes Elbow, Item 35)	1
6	052-0173-00	Condensing Coil	1	25	053-0613-01	Tube - Pressure Relief	1
7	053-0391-01	Hose	1	26	015-0013-05	Cable Tie (High Temp)	4
8	002-0358-00	Lever Sensor Tube (Includes Item 9,10,16,30,and 31)	1	27	014-0217-00	Compression Connector (Refer to Kit [*])	1
9	015-0595-00	Terminal	1	28	053-0404-01	Tube-PCB Connector (Refer to Kit [*]) ...	1
10	041-0006-02	Locknut	1	29	002-0357-00	Temperature Probe Assembly	1
11	053-0393-00	O-ring	1	30	053-0407-00	Bushing	1
12	014-0209-00	Bulkhead Couple	1	31	030-0858-00	Level Sensor Assembly	1
13	014-0184-01	Male Elbow	1	32	014-0204-00	Tube	1
14	014-0203-00	Tube	1	33	014-0184-01	Male 90° Elbow	1
15		Condensing Tank Lid (Part of Item 1) ...	1	(*)	002-0593-01	(*)Pressure Sensor Tube Kit (Includes #'s 19, 23, 26, 27, & 28)	
16	014-0212-00	Connector	1				
17	014-0206-00	Tube	1				

Always Specify Model & Serial Number

Plumbing & Sensor Components

SECTION VI PARTS LIST M9 / M9D

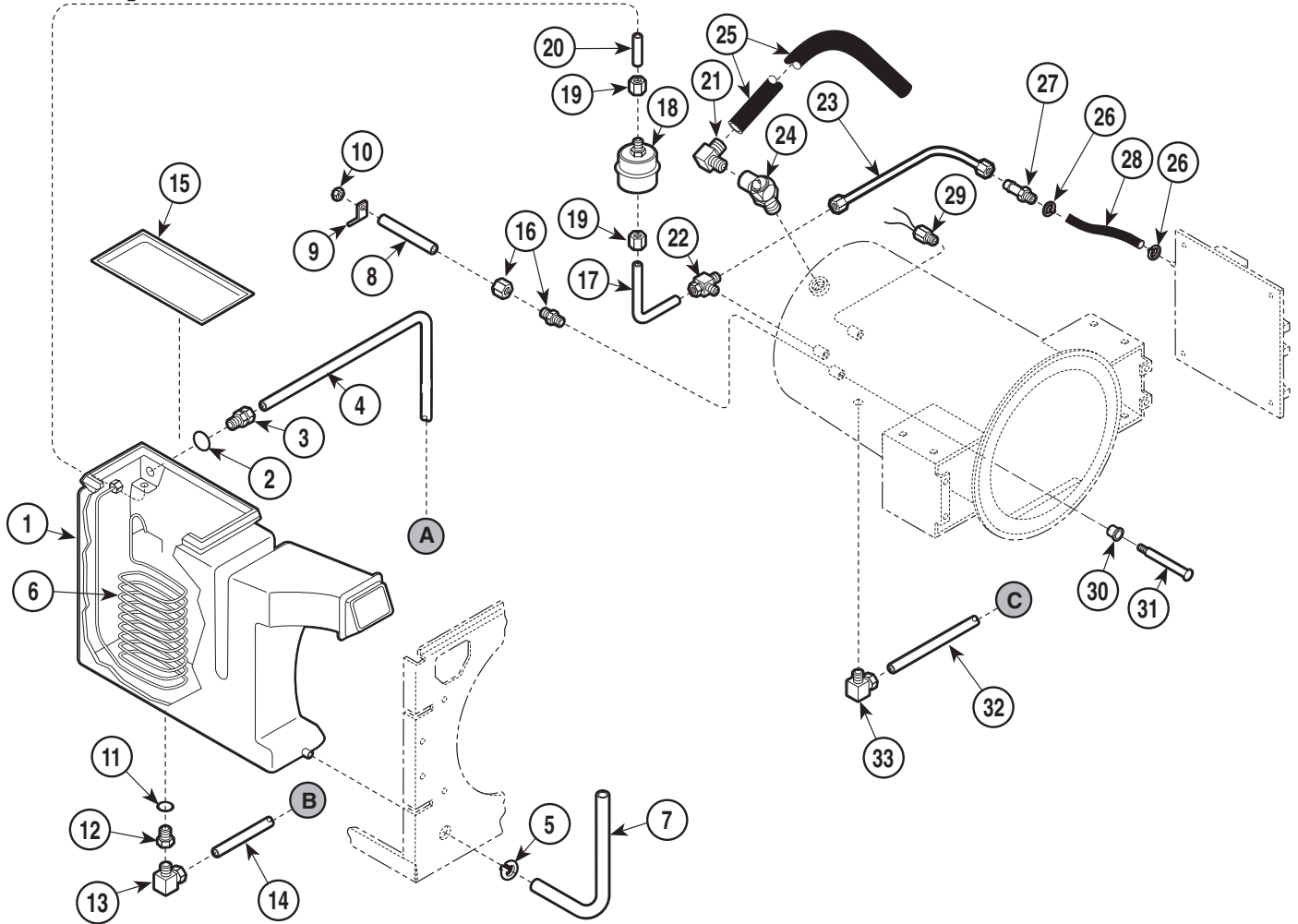

MA510809

Used on units with Serial Numbers:

CZ5945 thru CZ6530
FF1178 thru FF1264
LA1000 thru LA1023

DB1263 thru DB1272
FG1291 thru FG1327
OM17469 thru OM18880

DX2884 thru DX2878
FK2280 thru FK2304

FD1955 thru FD1954
FL1844 thru FL1948

Item	Part No.	Description	Qty.	Item	Part No.	Description	Qty.
1	053-0614-00	Condensing Tank (Includes Item 15)	1	18	002-0375-00	Bellows Assembly	1
2	H98137	Gasket	1	19	014-0392-00	Compression Nut (Refer to Kit [*])	2
3	014-0216-00	Bulkhead Union	1	20	014-0208-00	Tube	1
	014-0392-00	Compression Nut Only	AR	21	014-0258-00	Male Elbow	1
4	014-0205-00	Tube (M9)	1	22	014-0202-00	Male Branch Tee	1
	014-0277-00	Tube (M9D)	1	23	014-0315-00	PCB Pres. Sensor Tube (Refer to Kit [*])	1
5	016-0748-00	Hose Clip	1	24	002-0359-01	Pressure Relief Valve (40 P.S.I.) (Includes Elbow, Item 35)	1
6	052-0173-00	Condensing Coil	1	25	053-0613-01	Tube - Pressure Relief	1
7	053-0391-01	Hose	1	26	015-0013-05	Cable Tie (High Temp)	4
8	002-0358-00	Lever Sensor Tube (Includes Item 9,10,16,30, and 31)	1	27	014-0217-00	Compression Connector (Refer to Kit [*])	1
9	015-0595-00	Terminal	1	28	053-0404-04	Tube-PCB Connector (Refer to Kit [*]) ...	1
10	041-0006-02	Locknut	1	29	002-0357-00	Temperature Probe Assembly	1
11	053-0393-00	O-ring	1	30	053-0407-00	Bushing	1
12	014-0209-00	Bulkhead Couple	1	31	030-0858-00	Level Sensor Assembly	1
13	014-0184-01	Male Elbow	1	32	014-0204-00	Tube	1
14	014-0203-00	Tube	1	33	014-0184-01	Male 90° Elbow	1
15		Condensing Tank Lid (Part of Item 1)	1	(*)	002-0593-01	(*)Pressure Sensor Tube Kit (Includes #'s 19, 23, 26, 27, & 28)	
16	014-0212-00	Connector	1				
17	014-0206-00	Tube	1				

Always Specify Model & Serial Number

Plumbing & Sensor Components

SECTION VI PARTS LIST M9 / M9D

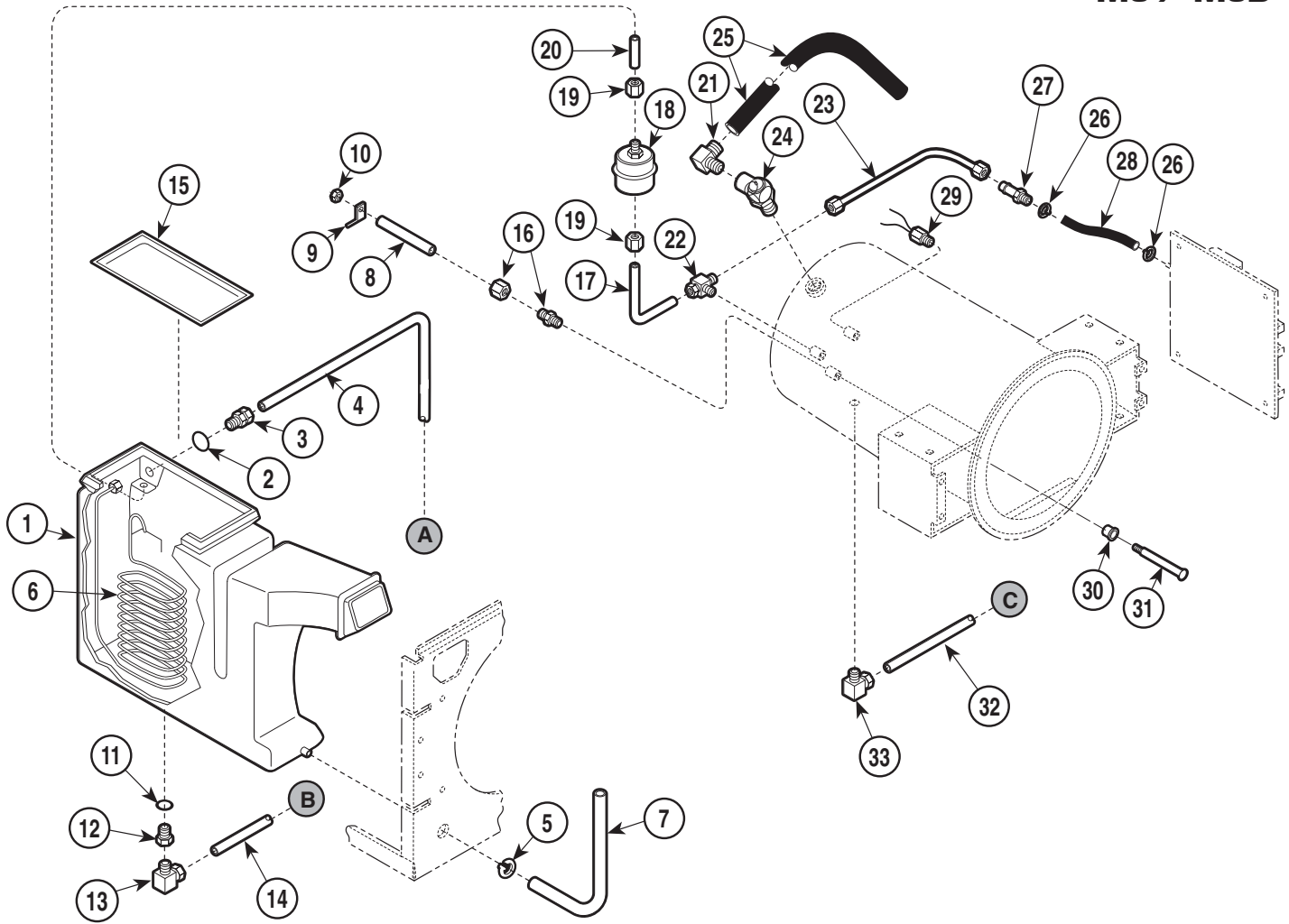

MA510809

Used on units with Serial Numbers:

CZ6531 thru CZ7236
FK2305 thru FK2324
FG1328 thru FG1386

DX2879 thru DX2906
FL1949 thru FL1963
OM18881 thru OM20225

DY1179 thru DY1182
LA1024 thru LA1028

FD1955 thru FD2104
FF1265 thru FF1290

Item	Part No.	Description	Qty.	Item	Part No.	Description	Qty.
1	053-0966-00	Condensing Tank (Includes Item 15)	1	18	002-0375-00	Bellows Assembly	1
2	H98137	Gasket	1	19	014-0392-00	Compression Nut (Refer to Kit [*])	2
3	014-0216-00	Bulkhead Union	1	20	014-0208-00	Tube	1
	014-0392-00	Compression Nut Only	AR	21	014-0258-00	Male Elbow	1
4	014-0205-00	Tube (M9)	1	22	014-0202-00	Male Branch Tee	1
	014-0277-00	Tube (M9D)	1	23	014-0315-00	PCB Pres. Sensor Tube (Refer to Kit [*])	1
5	016-0748-01	Hose Clip	1	24	002-0359-01	Pressure Relief Valve (40 P.S.I.)	
6	052-0173-00	Condensing Coil	1			(Includes Elbow, Item 35)	1
7	053-0391-01	Hose	1	25	053-0613-02	Tube - Pressure Relief	1
8	002-0358-00	Lever Sensor Tube (Includes Item		26	015-0013-05	Cable Tie (High Temp)	4
		9,10,16,30, and 31)	1	27	014-0217-00	Compression Connector (Refer to Kit [*])	1
9	015-0595-00	Terminal	1	28	053-0404-04	Tube - PCB Connector (Refer to Kit [*])	1
10	041-0006-02	Locknut	1	29	002-0357-00	Temperature Probe Assembly	1
11	053-0393-00	O-ring	1	30	053-0407-00	Bushing	1
12	014-0209-00	Bulkhead Couple	1	31	030-0858-00	Level Sensor Assembly	1
13	014-0184-01	Male Elbow	1	32	014-0204-00	Tube	1
14	014-0203-00	Tube	1	33	014-0184-01	Male 90° Elbow	1
15		Condensing Tank Lid (Part of Item 1)	1	(*)	002-0593-01	(*)Pressure Sensor Tube Kit (Includes #'s	
16	014-0212-00	Connector	1			19, 23, 26, 27, & 28)	
17	014-0206-00	Tube	1				

Always Specify Model & Serial Number

Plumbing & Sensor Components

SECTION VI PARTS LIST M9 / M9D

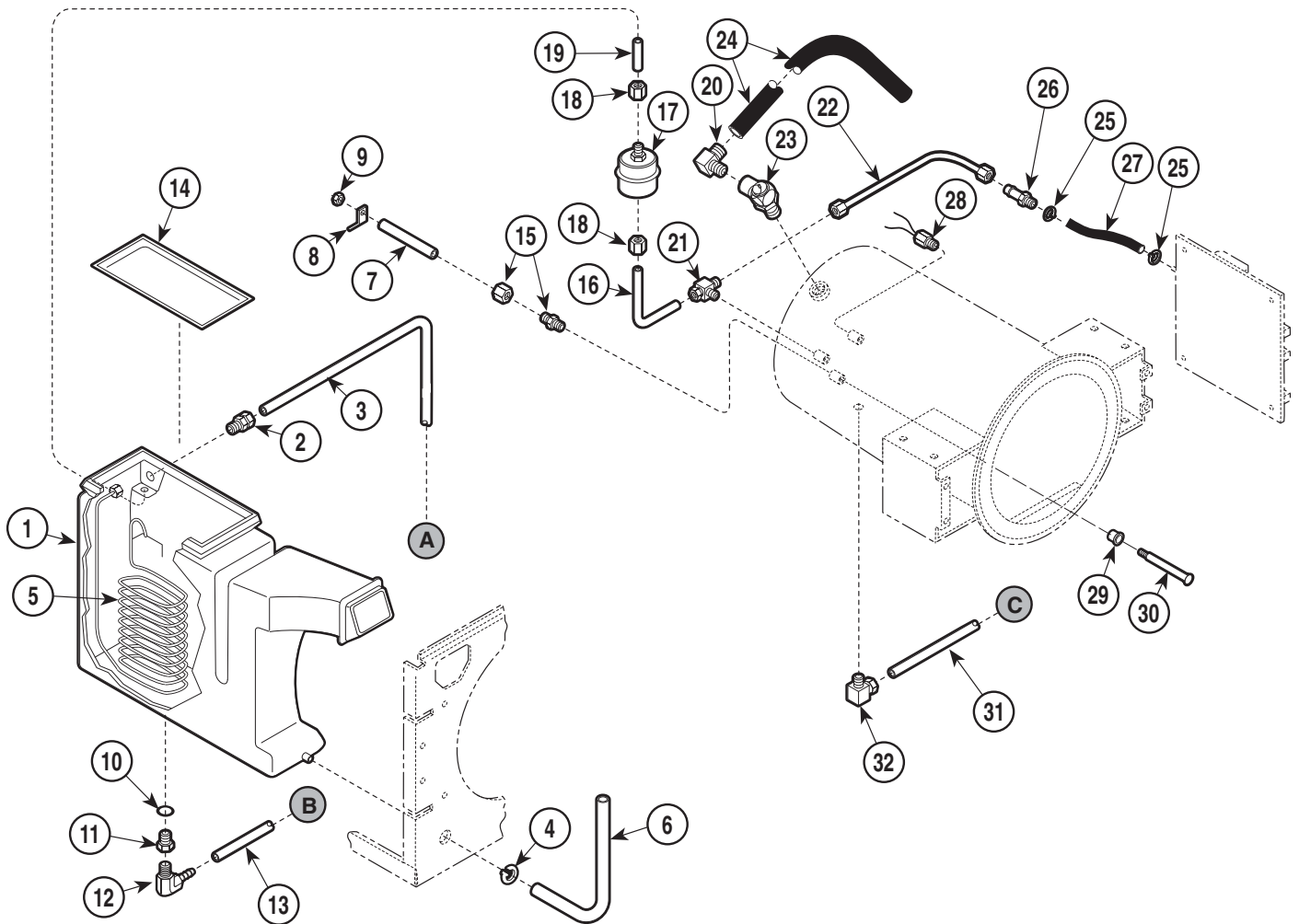

MA510804

Used on units with Serial Numbers:

CZ7237 thru CZ10064
FD2105 thru FD2264

DB1273 thru DB1282
FF1291 thru FF1736

DX2907 thru DX3147
FG1387 thru FG1617

DY1183 thru DY1190
OM20226 thru OM25095

Item	Part No.	Description	Qty.	Item	Part No.	Description	Qty.
1	053-0966-00	Condensing Tank (Includes Item 15)	1	17	002-0375-00	Bellows Assembly	1
2	014-0216-00	Bulkhead Union	1	18	014-0392-00	Compression Nut (Refer to Kit [*])	2
	014-0392-00	Compression Nut Only	AR	19	014-0208-00	Tube	1
3	014-0205-00	Tube (M9)	1	20	014-0258-00	Male Elbow	1
	014-0277-00	Tube (M9D)	1	21	014-0202-00	Male Branch Tee	1
4	016-0748-01	Hose Clip	1	22	014-0315-00	PCB Pres. Sensor Tube (Refer to Kit [*])	1
5	052-0173-00	Condensing Coil	1	23	002-0359-01	Pressure Relief Valve (40 P.S.I.) (Includes Elbow, Item 34)	1
6	053-0391-01	Hose	1	24	053-0613-02	Tube - Pressure Relief	1
7	002-0358-00	Lever Sensor Tube (Includes Item 8,9,15,29, and 30)	1	25	015-0013-05	Cable Tie (High Temp)	2
8	015-0595-00	Terminal	1	26	014-0217-00	Compression Connector (Refer to Kit [*])	1
9	041-0006-02	Locknut	1	27	053-0404-04	Tube - PCB Connector (Refer to Kit [*])	1
10	053-0393-00	O-ring	1	28	002-0357-00	Temperature Probe Assembly	1
11	014-0209-00	Bulkhead Couple	1	29	053-0407-00	Bushing	1
12	014-0348-00	Barb Fitting Elbow	1	30	030-0858-00	Level Sensor Assembly	1
13	053-1033-01	Norprene Tubing	1	31	014-0204-00	Tube	1
14		Condensing Tank Lid (Part of Item 1)	1	32	014-0184-01	Male 90° Elbow	1
15	014-0212-00	Connector	1	(*)	002-0593-01	(*)Pressure Sensor Tube Kit (Includes #'s 18, 22, 25, 26, & 27)	
16	014-0206-00	Tube	1				

Always Specify Model & Serial Number

Plumbing & Sensor Components

SECTION VI PARTS LIST M9 / M9D

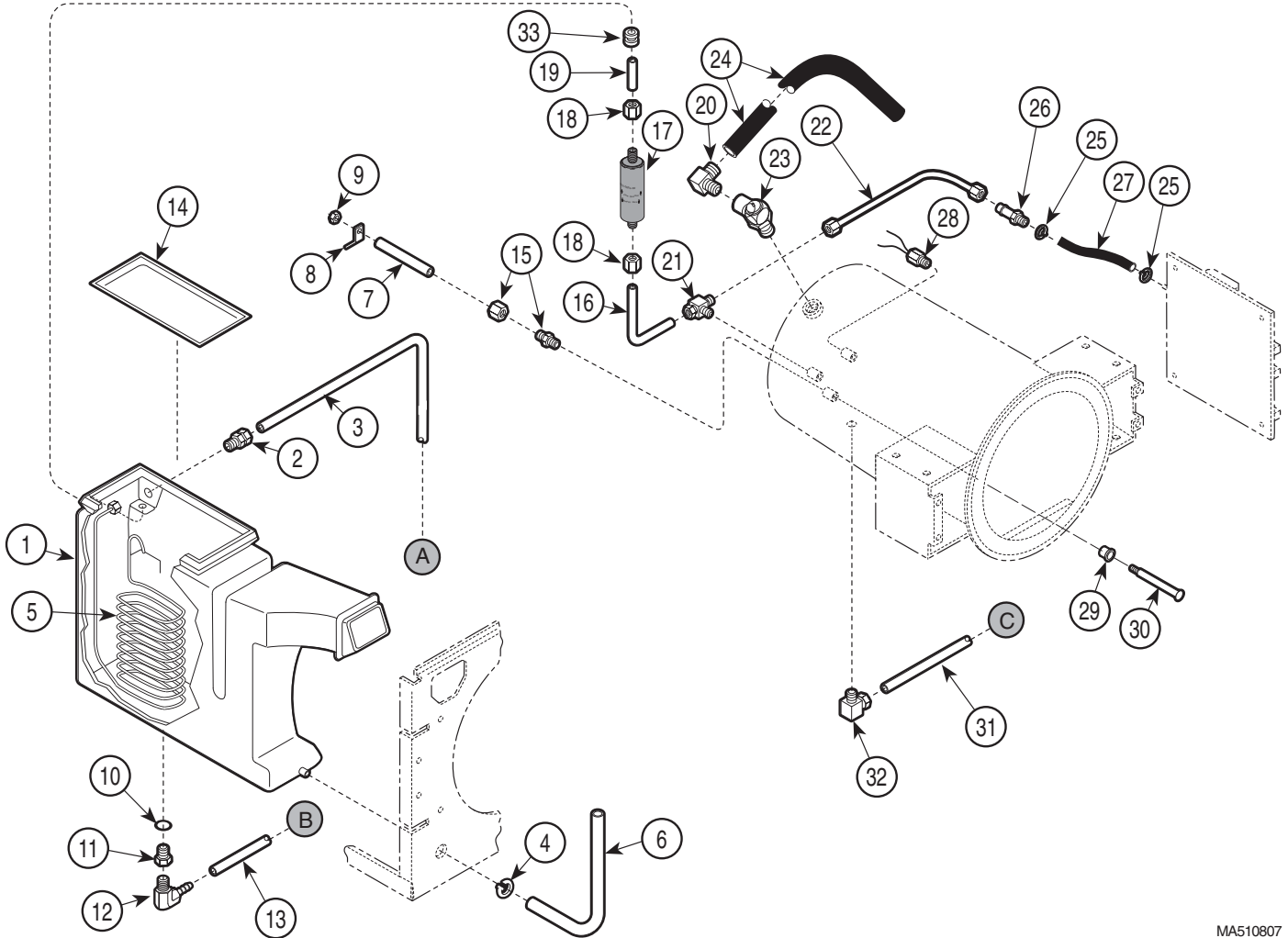

MA510807

Used on units with Serial Numbers:

CZ10065, DA1005, DB1283, DX3148, DY1191, FD2265, FF1737, FG1618, FK2325, FL1964, LA1029, OM25096 - thru Present

Item	Part No.	Description	Qty.	Item	Part No.	Description	Qty.
1	053-0966-00	Condensing Tank (Includes Item 15)	1	18	014-0392-00	Compression Nut (Refer to Kit [*])	2
2	014-0216-00	Bulkhead Union	1	19	014-0208-00	Tube	1
3	014-0392-00	Compression Nut Only	AR	20	014-0258-00	Male Elbow	1
3	014-0205-00	Tube (M9)	1	21	014-0202-00	Male Branch Tee	1
	014-0277-00	Tube (M9D)	1	22	014-0315-00	PCB Pres. Sensor Tube (Refer to Kit [*])	1
4	016-0748-01	Hose Clip	1	23	002-0359-01	Pressure Relief Valve (40 P.S.I.) (Includes Elbow, Item 34)	1
5	052-0173-00	Condensing Coil	1	24	053-0613-02	Tube - Pressure Relief	1
6	053-0391-01	Hose	1	25	015-0013-05	Cable Tie (High Temp)	2
7	002-0358-00	Lever Sensor Tube (Includes Item 8,9,15,29, and 30)	1	26	014-0217-00	Compression Connector (Refer to Kit [*])	1
8	015-0595-00	Terminal	1	27	053-0404-04	Tube - PCB Connector (Refer to Kit [*])	1
9	041-0006-02	Locknut	1	28	002-0357-00	Temperature Probe Assembly	1
10	053-0393-00	O-ring	1	29	053-0407-00	Bushing	1
11	014-0209-00	Bulkhead Couple	1	30	030-0858-00	Level Sensor Assembly	1
12	014-0348-00	Barb Fitting Elbow	1	31	014-0204-00	Tube	1
13	053-1033-01	Norprene Tubing	1	32	014-0184-01	Male 90° Elbow	1
14	053-0966-01	Condensing Tank Lid (Part of Item 1)	1	33	053-0394-02	Grommet	1
15	014-0212-00	Connector	1	(*)	002-0593-01	(*Pressure Sensor Tube Kit (Includes #'s 18, 22, 25, 26, & 27)	1
16	014-0431-00	Tube	1				
17	002-0654-00	Steam Trap Assembly (Includes Items 16, 18, 19, and 33)	1				

Always Specify Model & Serial Number

Pressure Vessel Components

SECTION VI PARTS LIST M9 / M9D

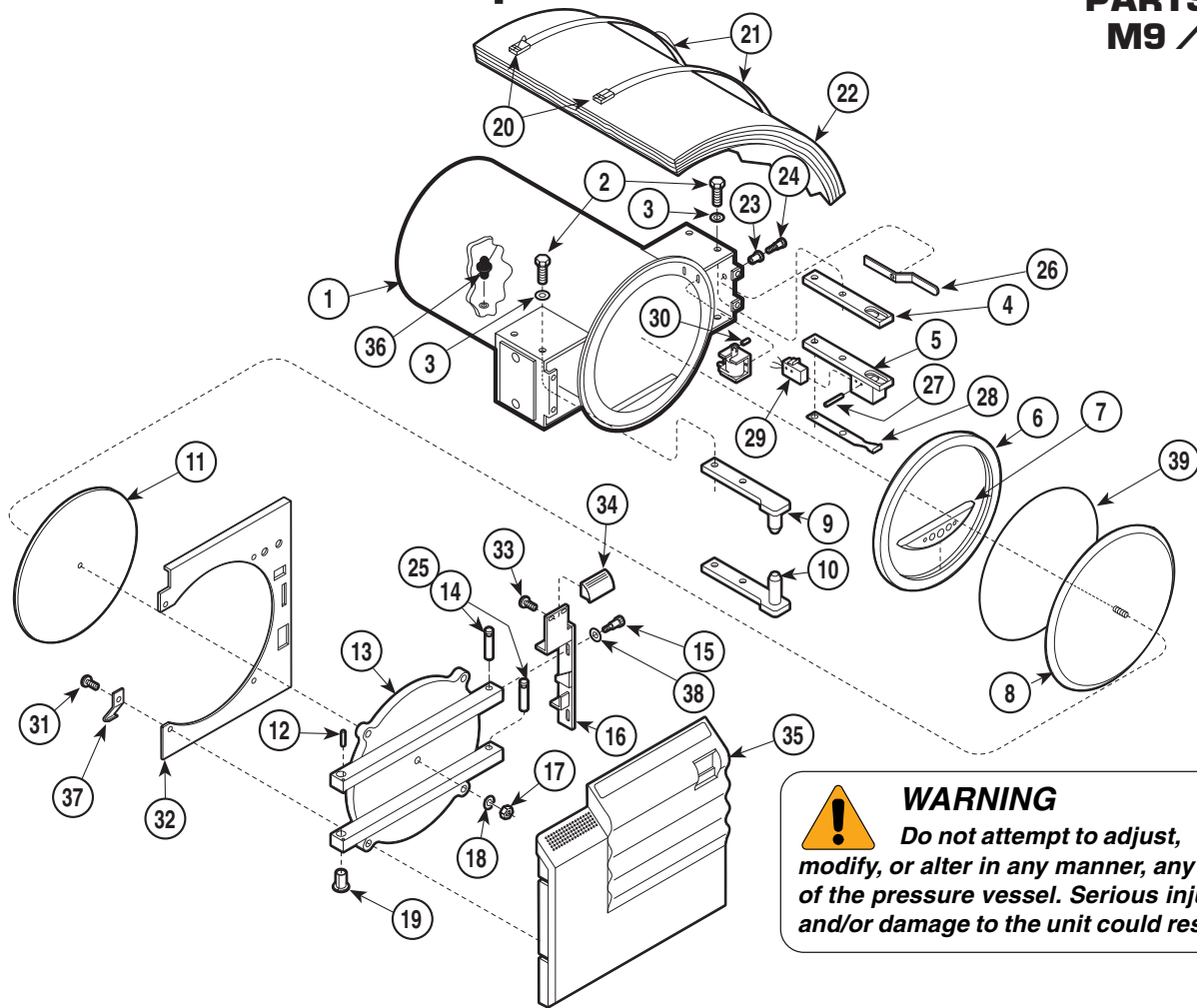

WARNING
Do not attempt to adjust, modify, or alter in any manner, any part of the pressure vessel. Serious injury and/or damage to the unit could result.

MA202010

Used on units with Serial Numbers:

CZ1000 thru CZ8199
FD1000 thru FD2131
FL1000 thru FL1963

DB1000 thru DB1277
FF1000 thru FF1634
LA1000 thru LA1028

DX1000 thru DX3006
FG1000 thru FG1471
OM1000 thru OM21774

DY1000 thru DY1185
FK1000 thru FK3224

Item	Part No.	Description	Qty.	Item	Part No.	Description	Qty.
1		Chamber	1	24	042-0106-01	Shoulder Screw (Not Used on M9D) (Apply Lubricant #064-0002-00)]	1
2		Screw	8	25	064-0014-00	Grease	AR
3		Washer	8	26	050-5192-00	Latch Lever (Not Used on M9D)	1
4		Right Bracket	1	27	042-0001-23	Roll Pin	2
5		Switch Weldment	1	28	050-2362-00	Spring Arm	1
6	053-0366-00	Door Gasket (Incl. in 002-0361-00 Kit) ..	1	29	002-0362-00	Door Switch (Includes Item 27)	1
7	053-0508-00	Dam Gasket (Incl. in 002-0361-00 Kit) ...	1	30	042-0001-09	Roll Pin (Not Used on M9D)	1
8	030-1016-00	Housing	1	31	040-0008-50	Screw	4
9		Top Bracket	1	32	050-2011-00	Inside Door Cover	1
10		Bottom Bracket	1	33	040-0010-75	Screw	2
11	016-0395-01	Door Insulation Pad	1	34	053-0912-00	Door Handle (M9)	1
12	042-0104-00	Roll Pin	1		(N.L.A.)	Door Handle (M9D)	1
13		Door	1	35	002-0364-00	Ritter M9 Door Panel (w/decals)	1
14		Door Bolt	2		002-0364-01	Midmark M9 Door Panel (w/decals)	1
15	042-0106-00	Shoulder Screw	2		002-0364-02	EMS M9 Door Panel (w/decals)	1
16	050-3525-00	Latch	1		(N.L.A.)	M9D Door Panel	1
17	041-0000-00	Nut	1	36	002-0360-00	Filter	1
18	045-0000-00	Lockwasher	1	37	050-2347-00	Door Spring	1
19		Flange Bearing	2	38	045-0000-04	Washer	2
20	H99387	Aluminum Seal	2	39	057-0790-01	Gasket Ring (Incl. in 002-0361-00 Kit)	1
21	H99388-36	Insulation Strap	2				
22	(N.L.A.)	Insulation Wrapper	1				
23	016-0131-18	Flanged Bearing (Not Used on M9D)	1				

Always Specify Model & Serial Number
N.L.A. Denotes "No Longer Available"

Pressure Vessel Components

SECTION VI PARTS LIST M9 / M9D

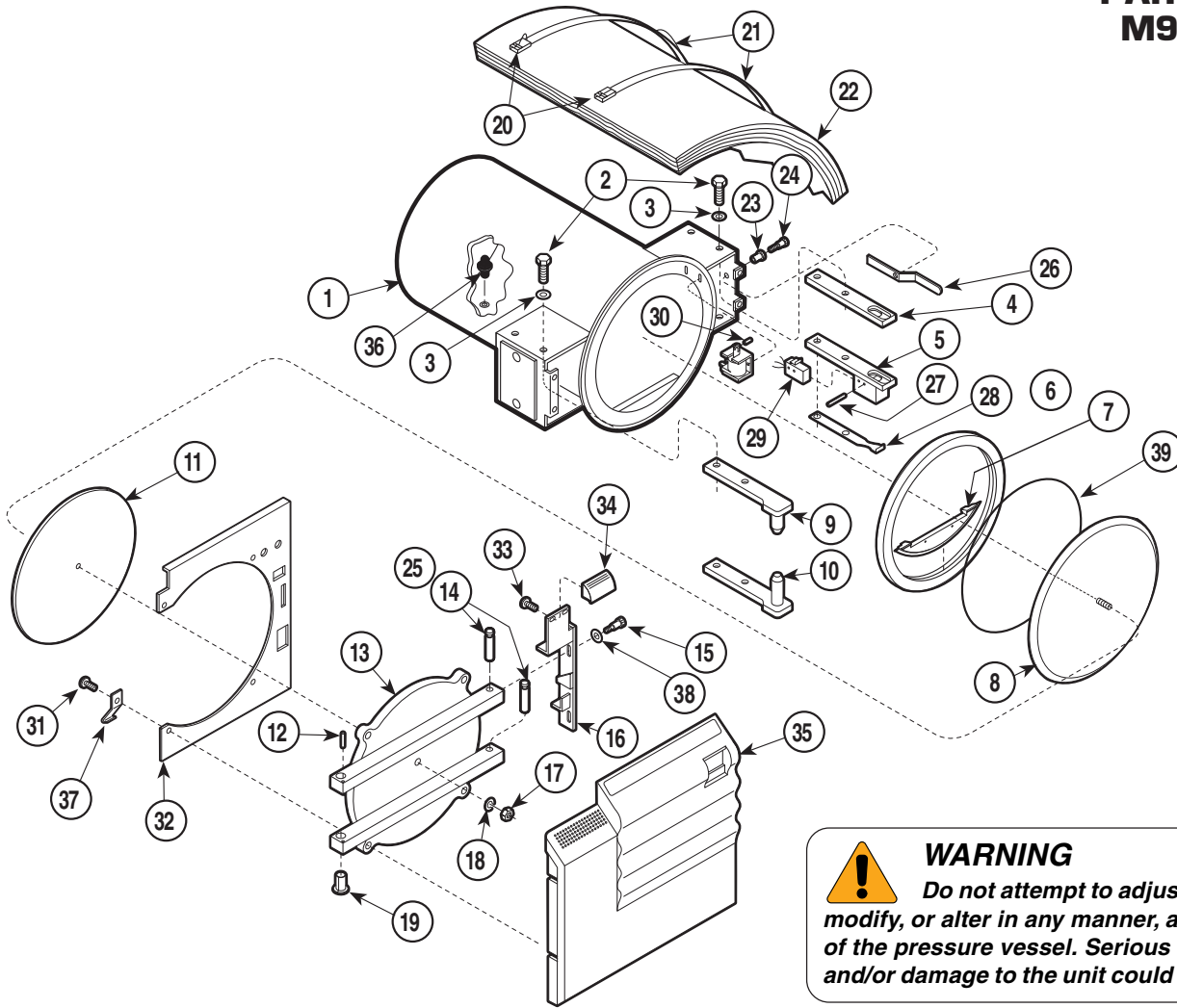

WARNING
Do not attempt to adjust, modify, or alter in any manner, any part of the pressure vessel. Serious injury and/or damage to the unit could result.

MA202013

Used on units with Serial Numbers:
CZ8200, DB1278, DX3007, DY1186, FD2132, FF1635, FG1472,
FK3225, FL1964, LA1029, and OM21775 - thru Present

Item	Part No.	Description	Qty.	Item	Part No.	Description	Qty.
1		Chamber	1	24	042-0106-01	Shoulder Screw (Not Used on M9D) (Apply Lubricant #064-0002-00)	1
2		Screw	8	25	064-0014-00	Grease	AR
3		Washer	8	26	050-5192-00	Latch Lever (Not Used on M9D)	1
4		Right Bracket	1	27	042-0001-23	Roll Pin	2
5		Switch Weldment	1	28	050-5245-01	Spring Arm	1
6	053-0366-00	Door Gasket (Incl. in 002-0361-01 Kit) ..	1	29	002-0362-00	Door Switch (Includes Item 27)	1
7	053-0903-00	Dam Gasket (Incl. in 002-0361-01 Kit) ...	1	30	042-0001-09	Roll Pin (Not Used on M9D)	1
8	030-1016-00	Housing	1	31	040-0008-50	Screw	4
9		Top Bracket	1	32	050-2011-00	Inside Door Cover	1
10		Bottom Bracket	1	33	040-0010-75	Screw	2
11	016-0395-01	Door Insulation Pad	1	34	053-0912-00	Door Handle (M9)	1
12	042-0104-00	Roll Pin	1		(N.L.A.)	Door Handle (M9D)	1
13		Door	1	35	002-0364-00	Ritter M9 Door Panel (w/decals)	1
14		Door Bolt	2		002-0364-01	Midmark M9 Door Panel (w/decals)	1
15	042-0106-00	Shoulder Screw	2		002-0364-02	EMS M9 Door Panel (w/decals)	1
16	050-3525-00	Latch	1		(N.L.A.)	M9D Door Panel	1
17	041-0000-00	Nut	1	36	002-0360-00	Filter	1
18	045-0000-00	Lockwasher	1	37	050-2347-00	Door Spring	1
19		Flange Bearing	2	38	045-0000-04	Washer	2
20	H99387	Aluminum Seal	2	39	057-0790-01	Gasket Ring (Incl. in 002-0361-01 Kit)	1
21	H99388-36	Insulation Strap	2				
22	(N.L.A.)	Insulation Wrapper	1				
23	016-0131-18	Flanged Bearing (Not Used on M9D)	1				

Always Specify Model & Serial Number
N.L.A. Denotes "No Longer Available"

M9 Manifold Components

SECTION VI PARTS LIST M9 / M9D

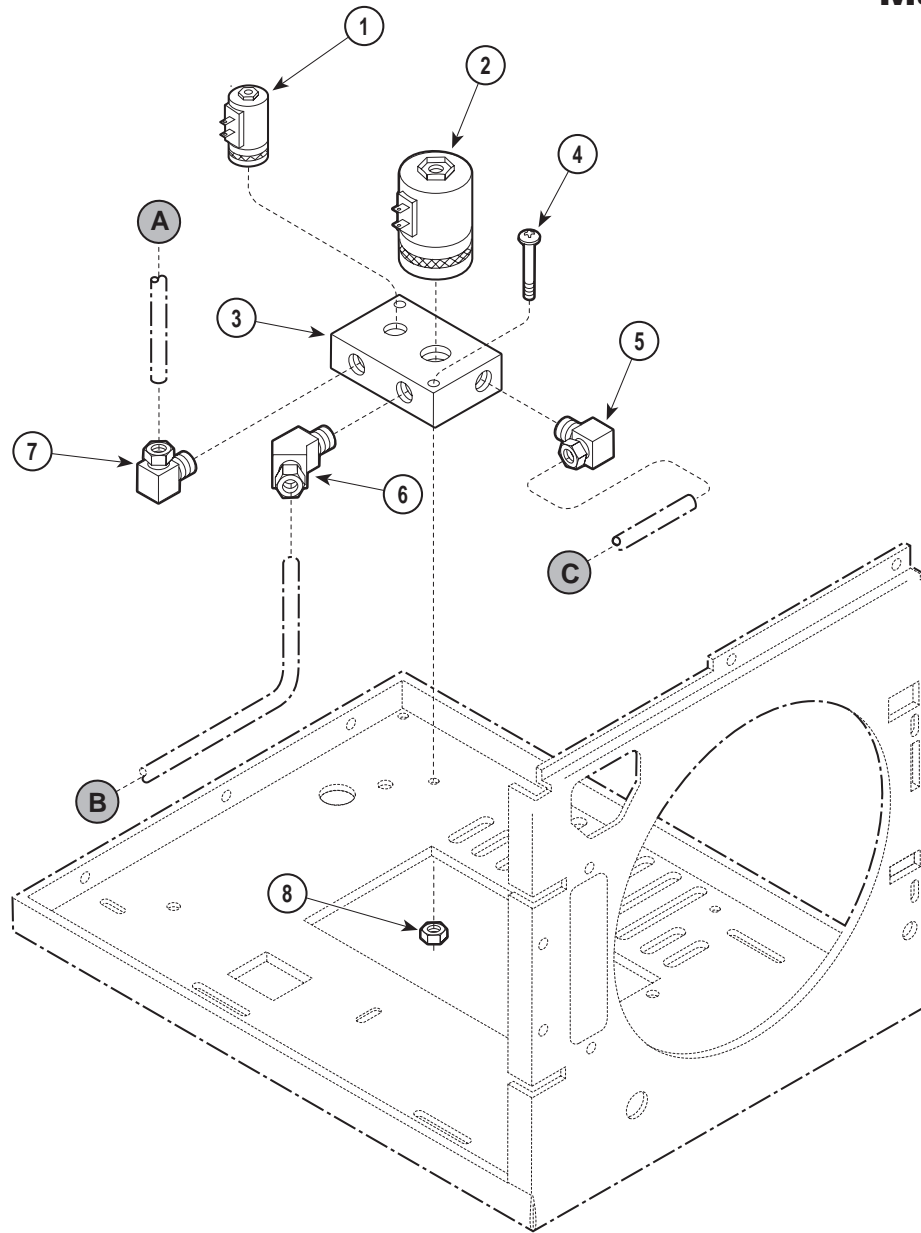

MA202102

Used on units with Serial Number CZ1000 thru CZ1109

Item	Part No.	Description	Qty.	Item	Part No.	Description	Qty.
1	014-0199-00	Solenoid Valve [Vent].....	1	5	014-0184-01	Male 90° Elbow.....	1
2	014-0200-00	Solenoid Valve [Fill].....	1	6	014-0201-00	Male 45° Elbow.....	1
3	014-0198-00	Manifold.....	1	7	014-0184-00	Male 90° Elbow.....	1
4	040-0010-53	Screw.....	2	8	014-0010-04	Nut.....	2

Always Specify Model & Serial Number

M9 Manifold Components

SECTION VI PARTS LIST M9 / M9D

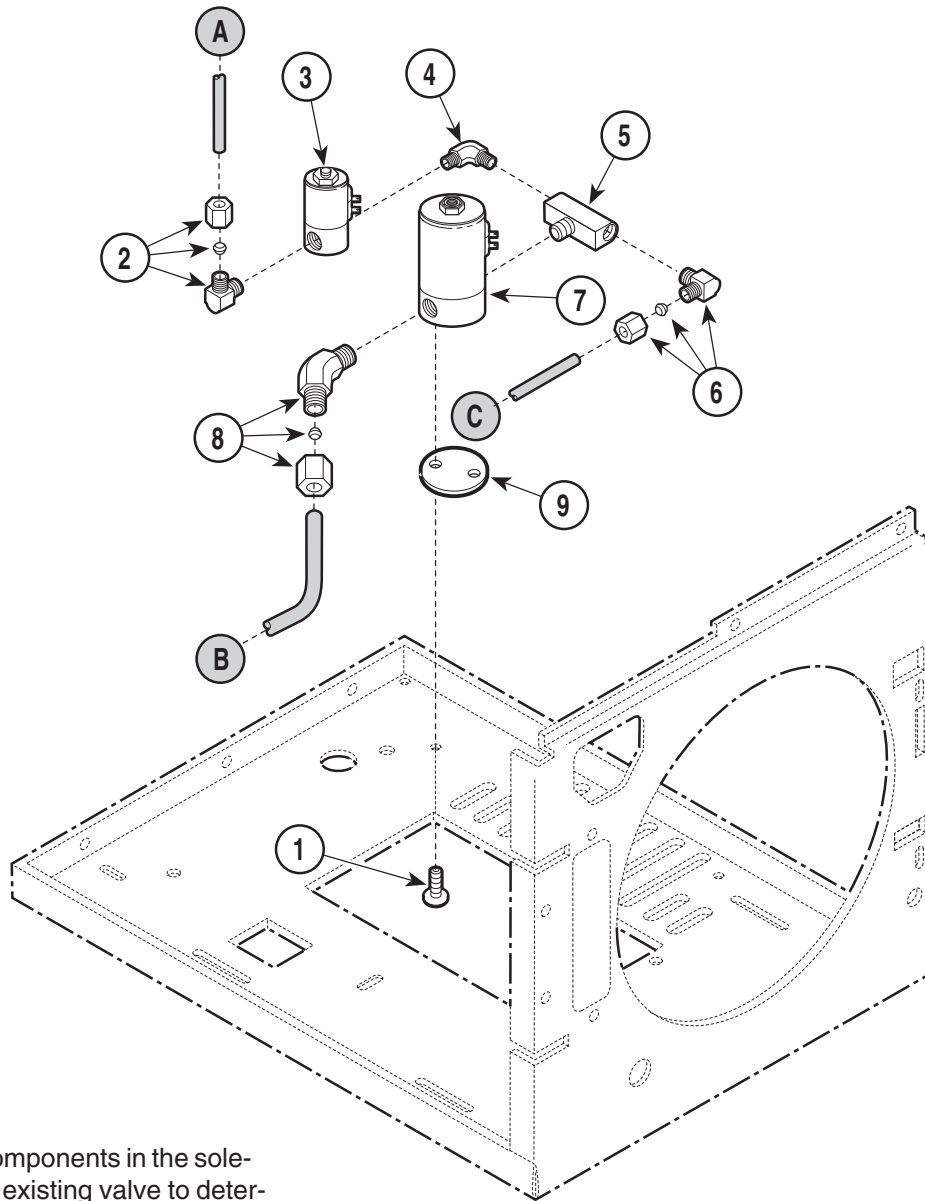

NOTE

When replacing components in the solenoid, examine the existing valve to determine if it was Full Wave Rectified (if so, will be marked **FWR**).

MA202205

Used on units with Serial Numbers:

CZ1110 thru CZ7236
DY1000 thru DY1182

DA1000 thru DA1006
FD1000 thru FD2104
LA1000 thru LA1028

DB1000 thru DB1272
FK1000 thru FK2324
OM1000 thru OM20225

DX1000 thru DX2906
FL1000 thru FL1963

Item	Part No.	Description	Qty.	Item	Part No.	Description	Qty.
	002-1428-00	Manifold Assembly (120V/60Hz) (includes items 2 thru 8)		5	•014-0234-00	Male Branch Tee	1
	002-1428-01	Manifold Assembly (230V/50Hz) (includes items 2 thru 8)		6	•014-0184-01	Male 90° Elbow	1
1	040-0010-74	Screw	2	7	•002-0365-00	Solenoid Valve (120V/60Hz) [Fill]	1
2	•014-0184-00	Male 90° Elbow	1		•002-0365-01	Solenoid Valve (230V/50Hz) [Fill]	1
3	•002-0366-00	Solenoid Valve {120V/60Hz} [Vent]	1		•002-0365-02	Solenoid Valve (100V/50Hz) [Fill]	1
	•002-0366-01	Solenoid Valve {230V/50Hz} [Vent]	1		•014-0236-08	• Replacement Coil (120V/60Hz)	1
	•002-0366-02	Solenoid Valve {100V/50Hz} [Vent]	1		•014-0236-10	• Replacement Coil (120V/50-60 FWR) ..	1
	••014-0235-03	• Replacement Coil (120V/60)	1		••014-0236-09	• Replmt. Plunger (120V/60Hz)	1
	••014-0235-04	• Replacement Plunger	1		••014-0236-11	• Replmt. Plunger (120V/50-60 FWR)	1
4	•014-0218-01	Male Elbow	1		••002-0694-00	• Replmt. Plunger & Coil (FWR)	1
				8	•014-0201-00	Male 45° Elbow	1
				9	050-2657-00	Spacer	1

Always Specify Model & Serial Number

M9 Manifold Components

SECTION VI PARTS LIST M9 / M9D

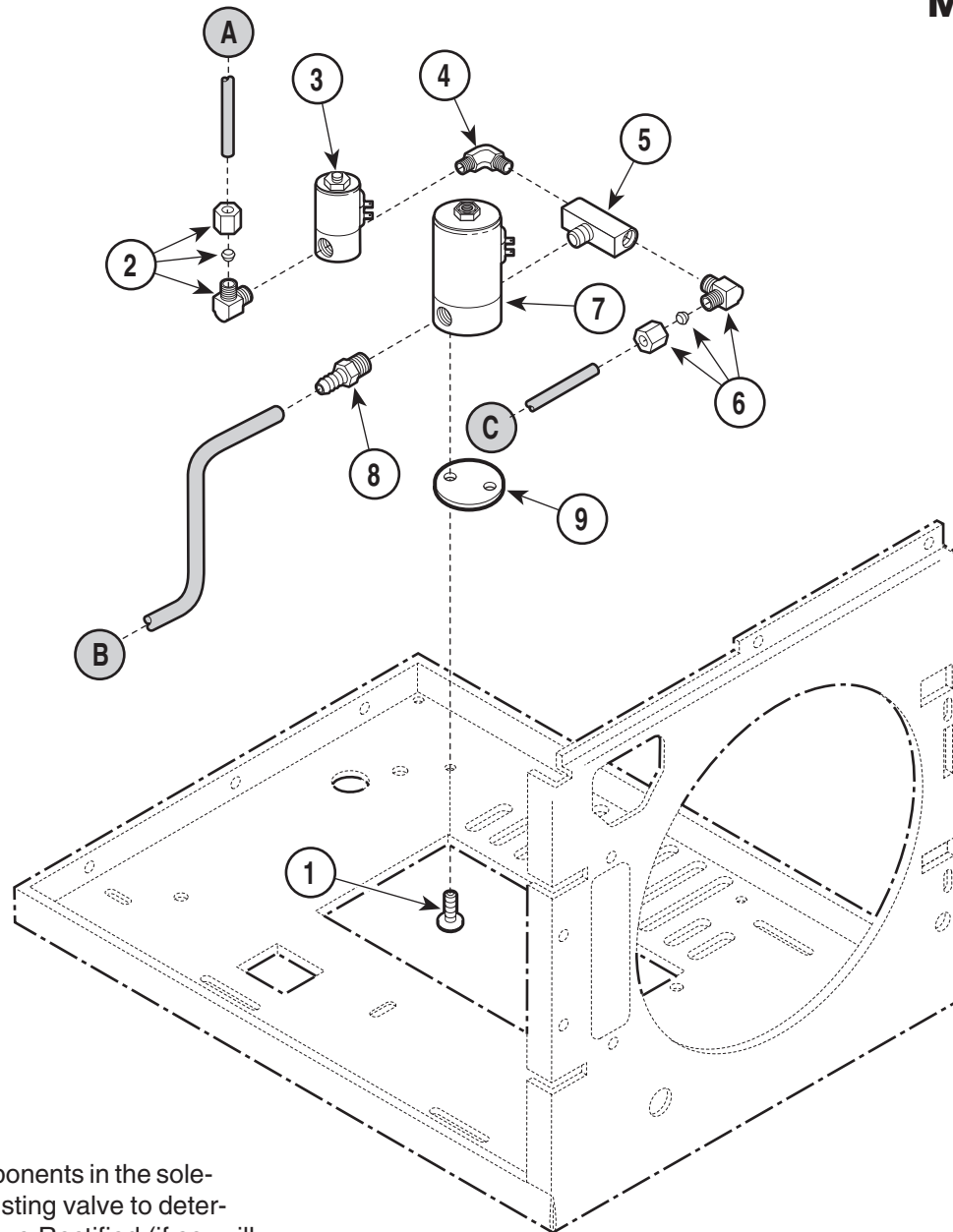

NOTE

When replacing components in the solenoid, examine the existing valve to determine if it was Full Wave Rectified (if so, will be marked **FWR**).

MA510701

Used on units with Serial Numbers:

**CZ7237, DA1007, DB1273, DX2907, DY1183, FD2105, FK2325,
FL1964, LA1029, and OM20226 - thru Present**

Item	Part No.	Description	Qty.	Item	Part No.	Description	Qty.
	029-1271-00	Manifold Assembly (120V/60Hz) (includes items 2 thru 8)		6	•014-0184-01	Male 90° Elbow	1
	029-1271-01	Manifold Assembly (230V/50Hz) (includes items 2 thru 8)		7	•002-0365-00	Solenoid Valve (120V/60Hz) [Fill]	1
1	040-0010-74	Screw	2		•002-0365-01	Solenoid Valve (230V/50Hz) [Fill]	1
2	•014-0184-00	Male 90° Elbow	1		•002-0365-02	Solenoid Valve (100V/50Hz) [Fill]	1
3	•002-0366-00	Solenoid Valve {120V/60Hz} [Vent]	1		•014-0236-08	• Replacement Coil (120V/60Hz)	1
	•002-0366-01	Solenoid Valve {230V/50Hz} [Vent]	1		•014-0236-10	• Replacement Coil (120V/50-60 FWR) ..	1
	•002-0366-02	Solenoid Valve {100V/50Hz} [Vent]	1		•014-0236-09	• Replmt. Plunger (120V/60Hz)	1
	•014-0235-03	• Replacement Coil (120V/60)	1		•014-0236-11	• Replmt. Plunger (120V/50-60 FWR)	1
	•014-0235-04	• Replacement Plunger	1		•002-0694-00	• Replmt. Plunger & Coil (FWR)	1
4	•014-0218-01	Male Elbow	1	8	•014-0347-00	Barb Fitting	1
5	•014-0234-00	Male Branch Tee	1	9	050-2657-00	Spacer (Used on units with flat base)	1

Always Specify Model & Serial Number

M9D Manifold Components

SECTION VI PARTS LIST M9 / M9D

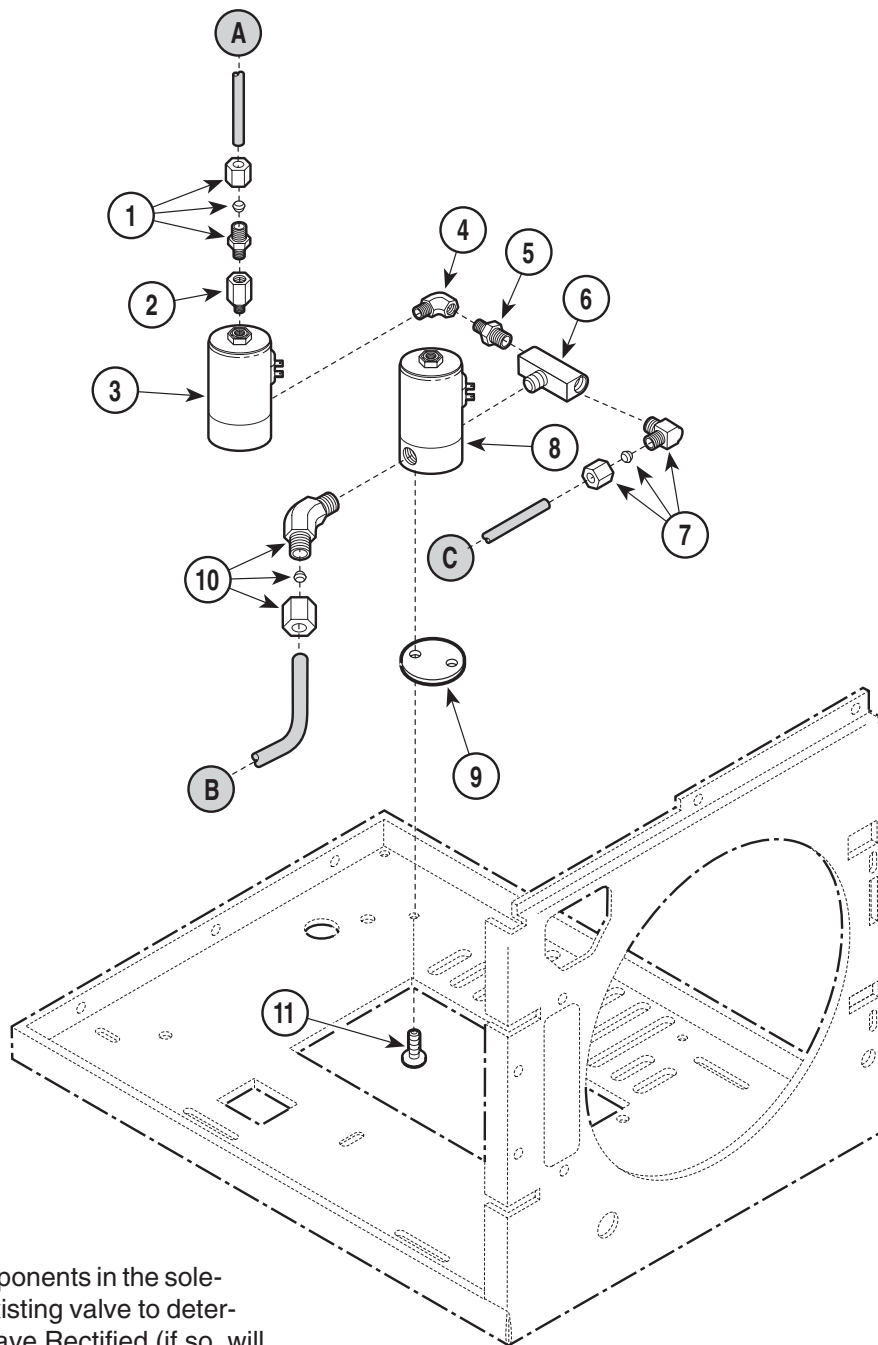

NOTE

When replacing components in the solenoid, examine the existing valve to determine if it was Full Wave Rectified (if so, will be marked **FWR**).

MA442700

Used on Units with Serial Numbers: FF1000 thru FF1290 FG1000 thru FG1386

Item	Part No.	Description	Qty.	Item	Part No.	Description	Qty.
1	014-0183-01	Male Connector	1	8	002-0365-00	Solenoid Valve(120V/60Hz)[Fill]	1
2		Reducer Fitting	1		• 014-0236-08	• Replacement Coil (120V/60Hz)	1
3	002-0519-00	Solenoid Valve {120V/60Hz} [Vent] (Includes Item 2)	1		• 014-0236-10	• Replacement Coil (120V/50-60 FWR) ..	1
	• 014-0275-02	• Replacement Coil & Plunger	1		• 014-0236-09	• Replmt. Plunger (120V/60Hz)	1
4	014-0194-00	Street Elbow	1		• 014-0236-11	• Replmt. Plunger (120V/50-60 FWR)	1
5	014-0276-00	Reducer Nipple	1	9	050-2657-00	Spacer	1
6	014-0234-00	Male Branch Tee	1	10	014-0201-00	Male 45° Elbow	1
7	014-0184-01	Male 90° Elbow	1	11	040-0010-74	Screw	2

Always Specify Model & Serial Number

M9D Manifold Components

SECTION VI PARTS LIST M9 / M9D

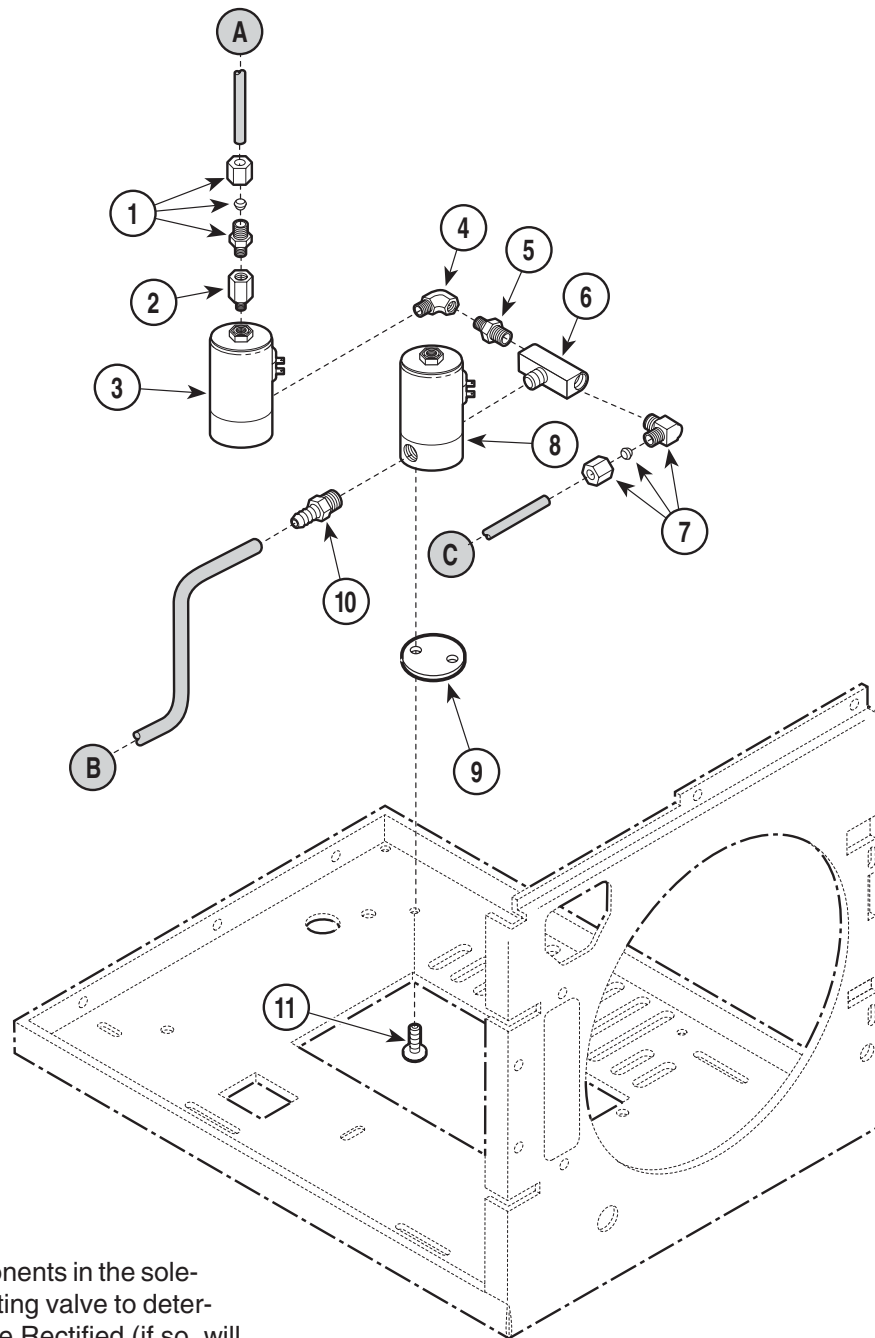

NOTE

When replacing components in the solenoid, examine the existing valve to determine if it was Full Wave Rectified (if so, will be marked **FWR**).

MA511100

Used on Units with Serial Numbers: FF1291, FG1387 - thru Present

Item	Part No.	Description	Qty.	Item	Part No.	Description	Qty.
1	014-0183-01	Male Connector	1	8	002-0365-00	Solenoid Valve(120V/60Hz)} [Fill]	1
2		Reducer Fitting	1		• 014-0236-08	• Replacement Coil (120V/60Hz)	1
3	002-0519-00	Solenoid Valve {120V/60Hz} [Vent] (Includes Item 2)	1		• 014-0236-10	• Replacement Coil (120V/50-60 FWR) ..	1
	• 014-0275-02	• Replacement Coil & Plunger	1		• 014-0236-09	• Replmt. Plunger (120V/60Hz)	1
4	014-0194-00	Street Elbow	1		• 014-0236-11	• Replmt. Plunger (120V/50-60 FWR)	1
5	014-0276-00	Reducer Nipple	1		• 002-0694-00	• Replmt. Plunger & Coil (FWR)	1
6	014-0234-00	Male Branch Tee	1	9	050-2657-00	Spacer (Used on Flat Surfaced Base) ...	1
7	014-0184-01	Male 90° Elbow	1	10	014-0347-00	Barb Fitting	1
				11	040-0010-74	Screw	2

Always Specify Model & Serial Number

Electrical Components

SECTION VI PARTS LIST M9 / M9D

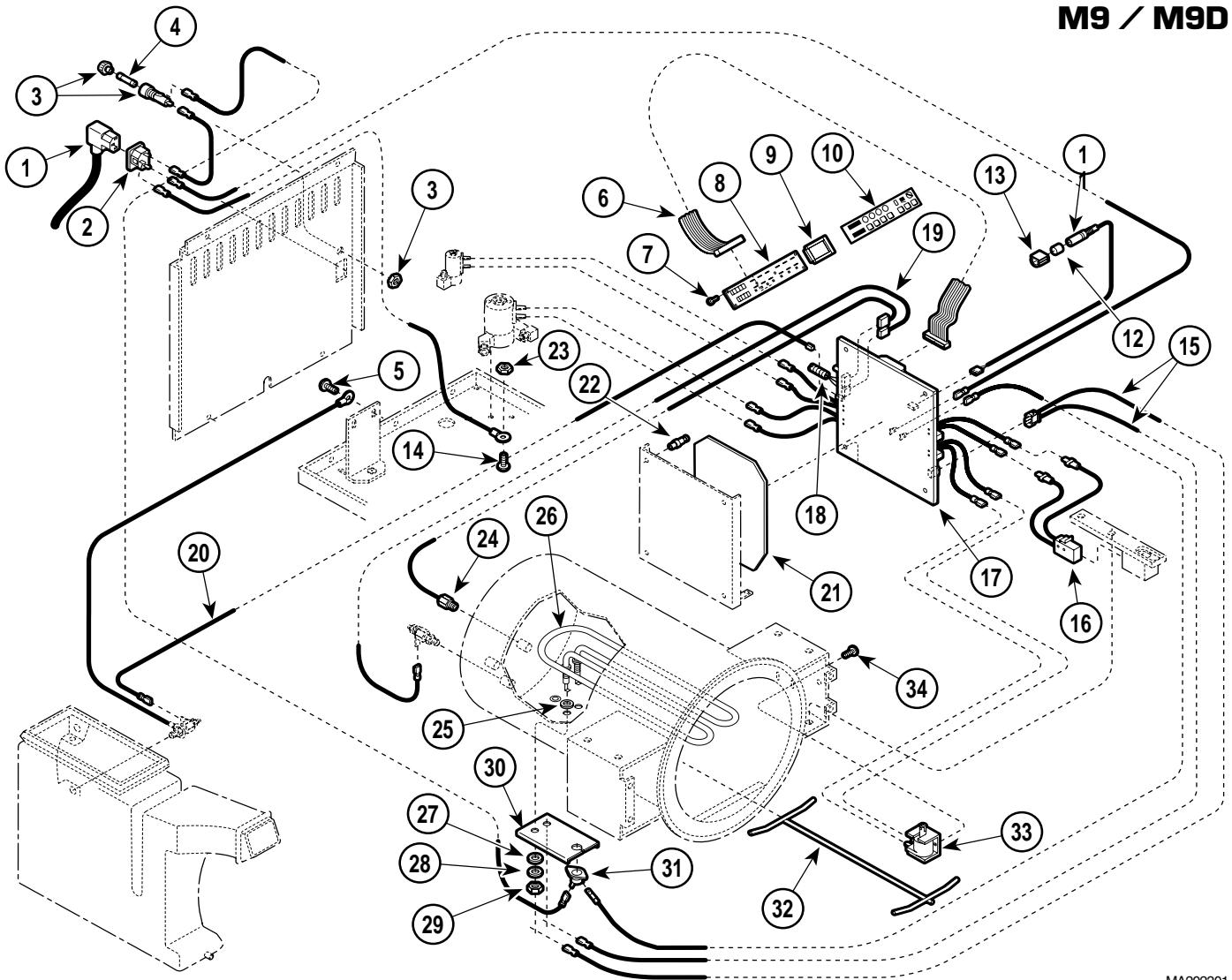

MA202301

Used on units with Serial Numbers:							
CZ1000 thru CZ1684		DA1000 thru DA1001		DB1000 thru DB1010			
DX1000 thru DX1170		DY1000 thru DY1007		OM1000 thru OM5130			
Item	Part No.	Description	Qty.	Item	Part No.	Description	Qty.
1		Cordset (Refer to Wiring Diagram).....	1	19	015-0654-00	Chamber Level Sensor Harness.....	1
2	015-0639-00	AC Connector Receptacle.....	1	20	015-0655-00	Reservoir Sensor Harness.....	1
3	A128003	Fuse Holder w/Nut (Early Units Only)...	1	21	053-0455-00	Insulator	1
4		Fuse	1	22	053-0295-01	Standoff	3
5	040-0010-75	Screw	1	23	041-0010-04	Locknut	1
6	015-0646-00	Ribbon Connector	1	24	002-0357-00	Temperature Probe Assembly.....	1
7	040-0006-04	Screw	6	25	H98137	Gasket	2
8	002-0369-00	Display PC Board (Domestic).....	1	26	002-0367-00	Heat Element-{120V}(Includes Item 25) 1	1
	002-0369-01	Display PC Board (Export).....	1		002-0367-01	Heat Element-{230V}(Includes Item 25) 1	1
9	053-0454-00	Display Gasket	1		002-0367-02	Heat Element-{100V}(Includes Item 25) 1	1
10	061-0272-01	Display Overlay (Domestic).....	1	27	H97971	Washer	2
	061-0272-00	Display Overlay (Export).....	1	28	045-0001-56	Lockwasher	2
11	015-0978-00	Harness - PCB/Printer.....	1	29	H97949	Nut	2
12	053-0440-00	Cap Plug	1	30	H225617	Bracket	1
13	053-0389-00	Printer Harness Clip.....	1	31	002-0370-00	Thermostat	1
14	040-0010-46	Screw	1	32	030-0769-00	Spacer Assembly	1
15	015-0657-00	PCB/Heater Harness	1	33	002-0363-00	Solenoid-{120V}	1
16	002-0362-00	Switch Assembly.....	1		002-0363-01	Solenoid-{240V}	1
17		Control PC Board (See Breakdown Elsewhere)	Ref		002-0363-02	Solenoid-{100V}	1
18	015-0257-02	Flex Guard Tubing.....	1	34	040-0010-74	Screw	2

Always Specify Model & Serial Number

Electrical Components

SECTION VI PARTS LIST M9 / M9D

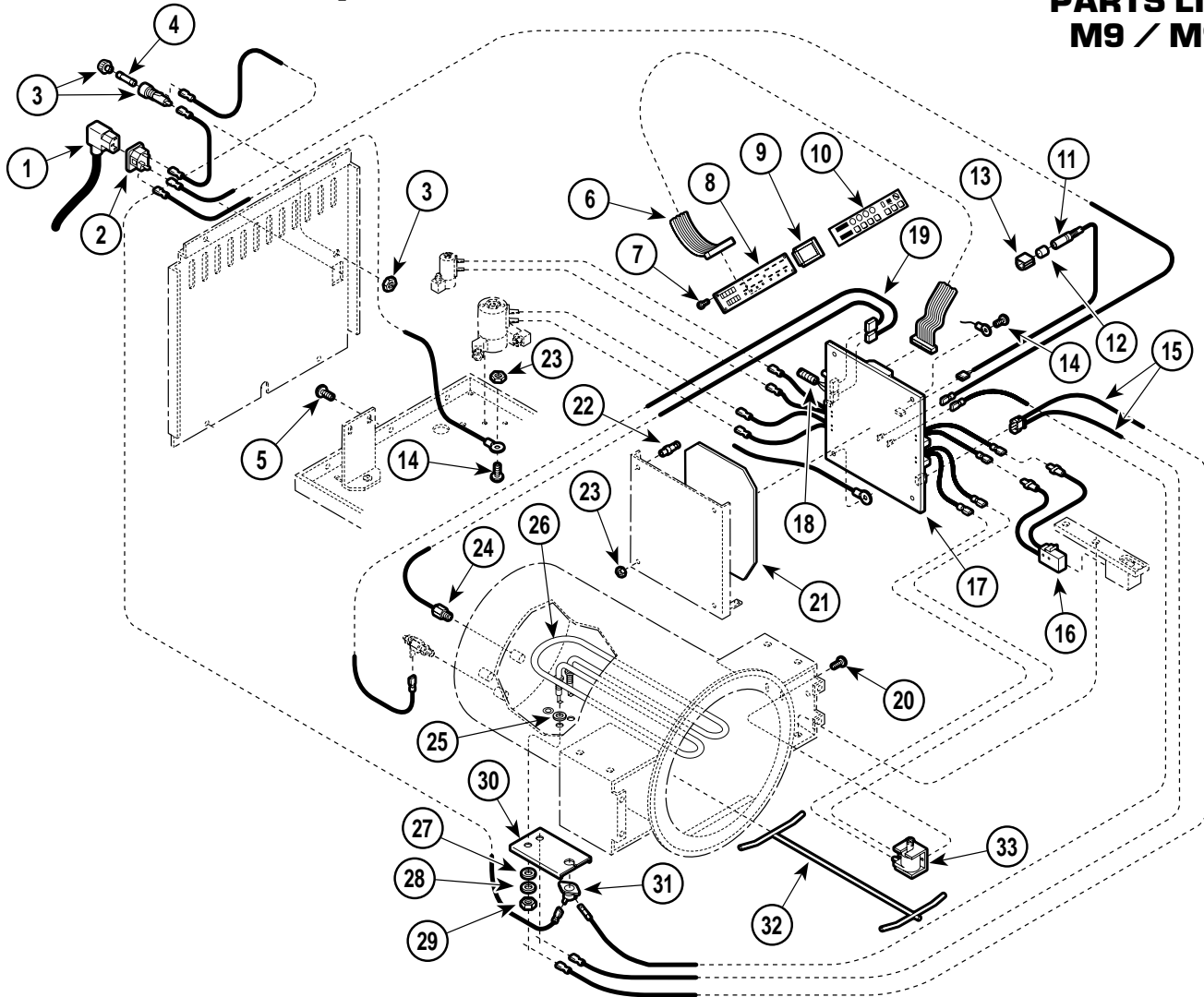

MA2023-02

Used on units with Serial Numbers:

**CZ1685 thru CZ2456
DX1171 thru DX1969**

**DA1002 thru DA1004
DY1008 thru DY1138**

**DB1011 thru DB1149
OM5131 thru OM9448**

Item	Part No.	Description	Qty.	Item	Part No.	Description	Qty.
1		Cordset (Refer to Wiring Diagram).....	1	19	015-0654-00	Chamber Level Sensor Harness.....	1
2	015-0639-00	AC Connector Receptacle.....	1	20	040-0010-74	Screw	2
3	A128003	Fuse Holder w/Nut (Early Units Only)...	1	21	053-0455-00	Insulator	2
4		Fuse	1	22	053-0295-01	Standoff	3
5	040-0010-75	Screw	1	23	041-0010-04	Locknut	1
6	015-0646-00	Ribbon Connector	1	24	002-0357-00	Temperature Probe Assembly.....	1
7	040-0006-04	Screw	6	25	H98137	Gasket	2
8	002-0369-00	Display PC Board (Domestic).....	1	26	002-0367-00	Heat Element-{120V}(Includes Item 25) 1	1
	002-0369-01	Display PC Board (Export).....	1		002-0367-01	Heat Element-{230V}(Includes Item 25) 1	1
9	053-0454-00	Display Gasket	1		002-0367-02	Heat Element-{100V}(Includes Item 25) 1	1
10	061-0272-01	Display Overlay (Domestic).....	1	27	H97971	Washer	2
	061-0272-00	Display Overlay (Export).....	1	28	045-0001-56	Lockwasher	2
11	015-0978-00	Harness - PCB/Printer.....	1	29	H97949	Nut	2
12	053-0440-00	Cap Plug	1	30	H225617	Bracket	1
13	053-0389-00	Printer Harness Clip	1	31	002-0370-00	Thermostat	1
14	040-0010-46	Screw	1	32	030-0769-00	Spacer Assembly	1
15	015-0657-00	PCB/Heater Harness	1	33	002-0363-00	Solenoid-{120V}	1
16	002-0362-00	Switch Assembly.....	1		002-0363-01	Solenoid-{240V}	1
17		Control PC Board (See Breakdown Elsewhere)	Ref		002-0363-02	Solenoid-{100V}	1
18	015-0257-02	Flex Guard Tubing.....	1				

Always Specify Model & Serial Number

Electrical Components

SECTION VI PARTS LIST M9 / M9D

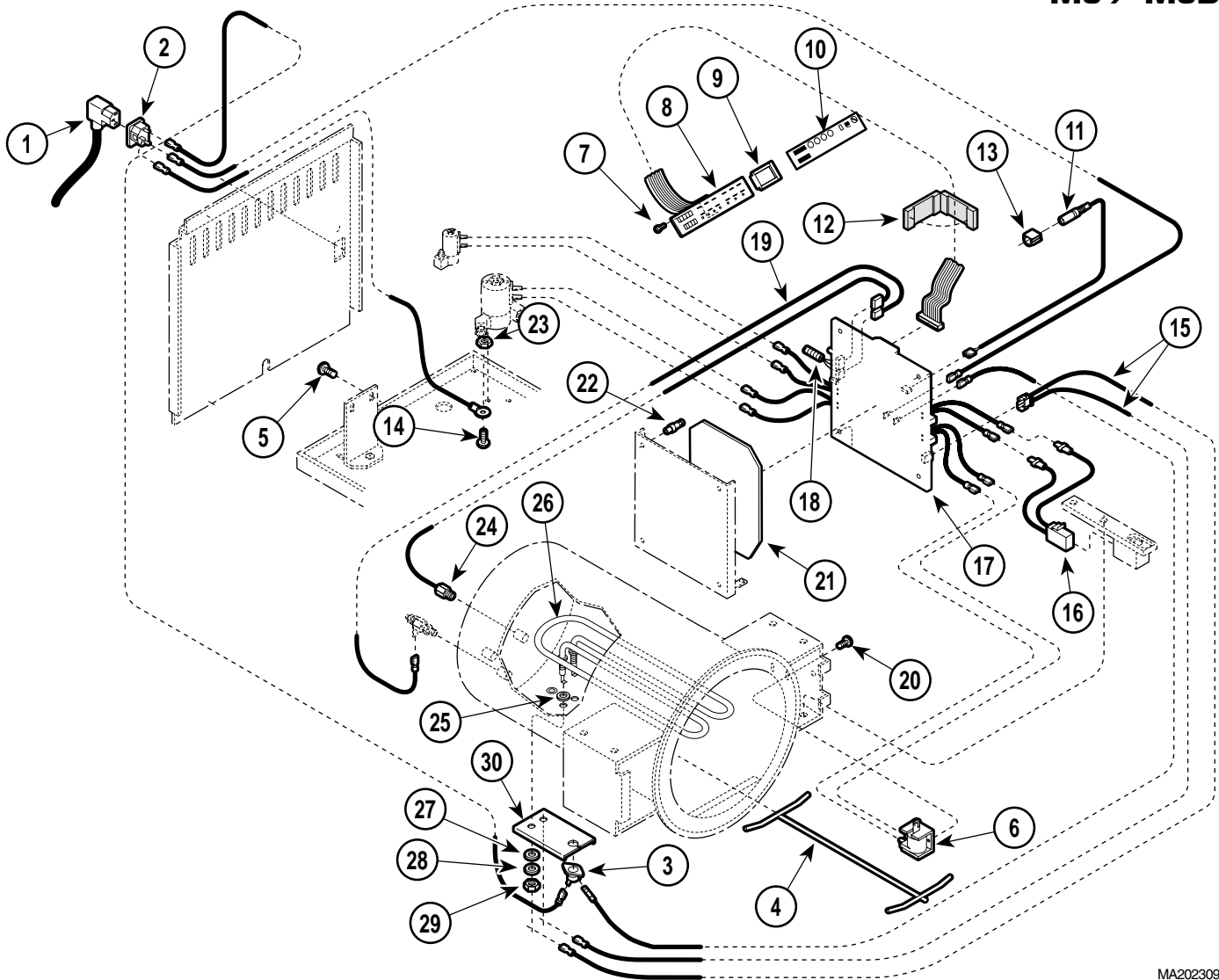

MA202309

Used on units with Serial Numbers:

CZ2457 thru CZ4590

FF1000 thru FF1054

FG1000 thru FG1137

OM9449 thru OM14723

Item	Part No.	Description	Qty.	Item	Part No.	Description	Qty.
1		Cordset (Refer to Wiring Diagram).....	1	14	040-0010-46	Screw	1
2	015-0639-00	AC Connector Receptacle.....	1	15	015-0657-00	PCB/Heater Harness	1
3	002-0370-00	Thermostat	1	16	002-0362-00	Switch Assembly.....	1
4	057-0425-00	Spacer Assembly.....	1	17		Control PC Board (Refer to "Control PC Board" Elsewhere)	Ref
5	040-0010-75	Screw	1	18	015-0257-02	Flex Guard Tubing	1
6	002-0363-00	Solenoid-{120V} (M9 only).....	1	19	015-0654-00	Chamber Level Sensor Harness.....	1
	002-0363-01	Solenoid-{240V} (M9 only).....	1	20	040-0010-74	Screw (M9 only).....	2
	002-0363-02	Solenoid-{100V} (M9 only).....	1	21	053-0455-00	Insulator	1
7	040-0006-04	Screw	6	22	053-0295-01	Standoff	3
8	002-0369-02	Display PC Board (Domestic).....	1	23	041-0010-04	Locknut	1
	002-0369-03	Display PC Board (Export).....	1	24	002-0357-00	Temperature Probe Assembly.....	1
9	053-0454-00	Display Gasket	1	25	H98137	Gasket	2
10	061-0272-01	M9 Display Overlay (Domestic).....	1	26	002-0367-00	Heat Element-{120V}(Includes Item 25)	1
	061-0272-00	M9 Display Overlay (Export)	1		002-0367-01	Heat Element-{230V}(Includes Item 25)	1
	061-0272-02	M9 Display Overlay (French)	1		002-0367-02	Heat Element-{100V}(Includes Item 25)	1
	061-0531-00	M9D Display Overlay.....	1	27	H97971	Washer	2
11		PCB/Printer Harness (Refer to "Printer Components" Elsewhere).....	1	28	045-0001-56	Lockwasher	2
12	015-1096-00	Flat Cable EMI Suppression (Used Only On Certain Export Units).....	1	29	H97949	Nut	2
13	053-0389-01	Printer Harness Clip.....	1	30	H225617	Bracket	1

Always Specify Model & Serial Number

Electrical Components

SECTION VI PARTS LIST M9 / M9D

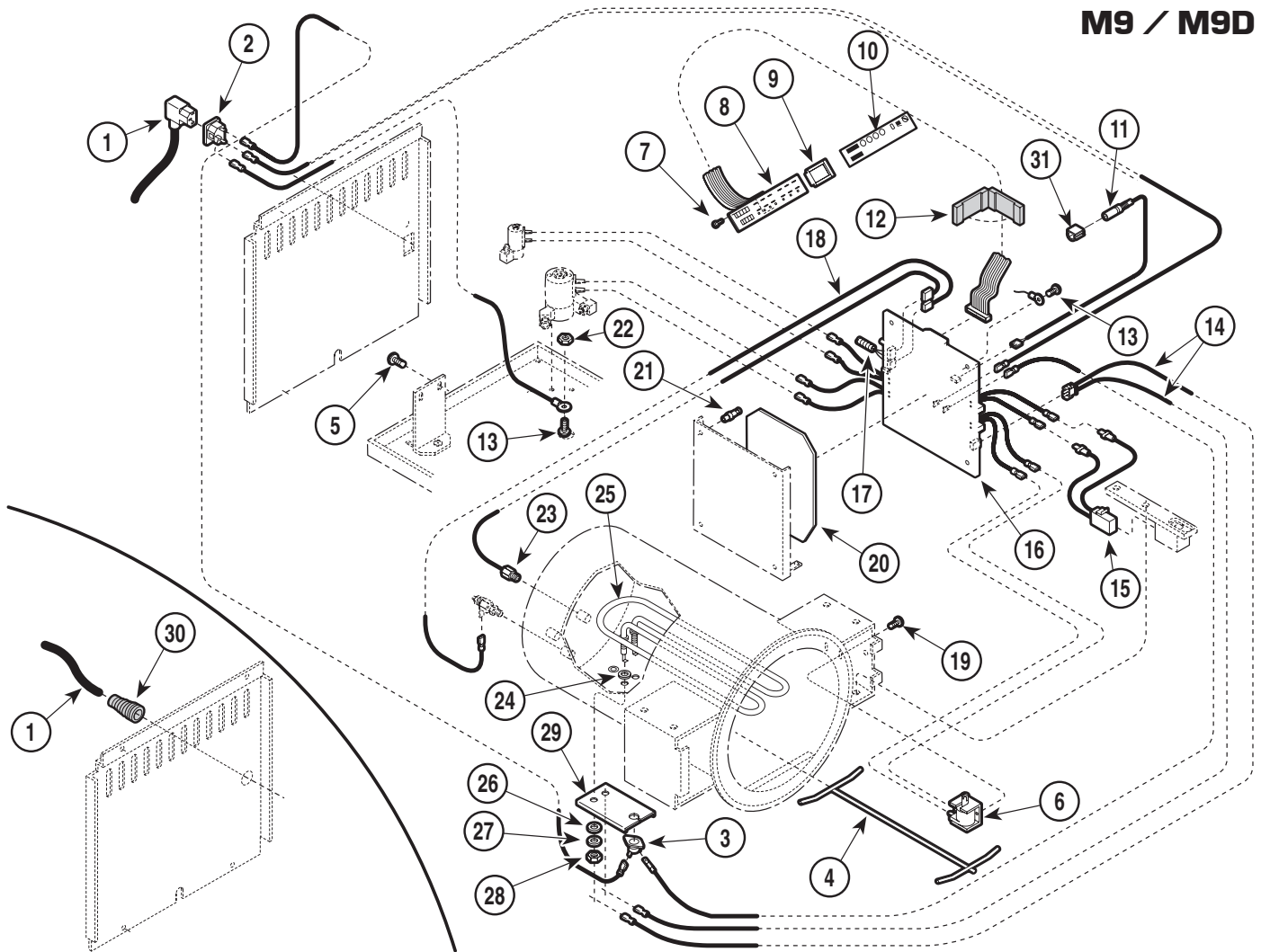

MA376103

Used on Units with Serial Numbers:
CZ4591, DA1005, DB1150, DX1970, DY1139, FD1000,
FK1000, FL1000, LA1000, and OM14724 - thru Present

Item	Part No.	Description	Qty.	Item	Part No.	Description	Qty.
1		Cordset (Refer to Wiring Diagram)	1	14	015-0657-00	PCB/Heater Harness	1
2	015-0639-00	AC Connector Receptacle	1	15	002-0362-00	Switch Assembly	1
3	002-0370-00	Thermostat	1	16		Control PC Board (Refer to "Control PC Board" Elsewhere)	Ref
4	057-0425-00	Spacer Assembly	1	17	015-0257-02	Flex Guard Tubing	1
5	040-0010-75	Screw	1	18	015-0654-00	Chamber Level Sensor Harness	1
6	002-0363-00	Solenoid-{120V}	1	19	040-0010-74	Screw	2
	002-0363-01	Solenoid-{240V}	1	20	053-0455-00	Insulator	1
	002-0363-02	Solenoid-{100V}	1	21	053-0295-01	Standoff	3
7	040-0006-04	Screw	6	22	041-0010-04	Locknut	1
8	002-0369-02	Display PC Board (Domestic)	1	23	002-0357-00	Temperature Probe Assembly	1
	002-0369-03	Display PC Board (Export)	1	24	H98137	Gasket	2
9	053-0454-00	Display Gasket	1	25	002-0367-00	Heat Element-{120V}(Includes Item 24) .	1
10	061-0272-01	Display Overlay (Domestic)	1		002-0367-01	Heat Element-{230V}(Includes Item 24) .	1
	061-0272-00	Display Overlay (Export)	1		002-0367-02	Heat Element-{100V}(Includes Item 24) .	1
	061-0272-02	Display Overlay (French)	1	26	H97971	Washer	2
	061-0702-18	Display Overlay (Polish)	1	27	045-0001-56	Lockwasher	2
11		PCB/Printer Harness (Refer to "Printer Components" Elsewhere)	1	28	H97949	Nut	2
12	015-1096-00	Flat Cable EMI Suppression (Used Only On Certain Export Units)	1	29	050-3503-00	Bracket	1
13	040-0010-46	Screw	1	30	015-1137-00	Strain Relief Bushing (120 V. Units Only)	1
				31	053-0389-01	Printer Harness Clip	1

Always Specify Model & Serial Number

Electrical Components

SECTION VI PARTS LIST M9 / M9D

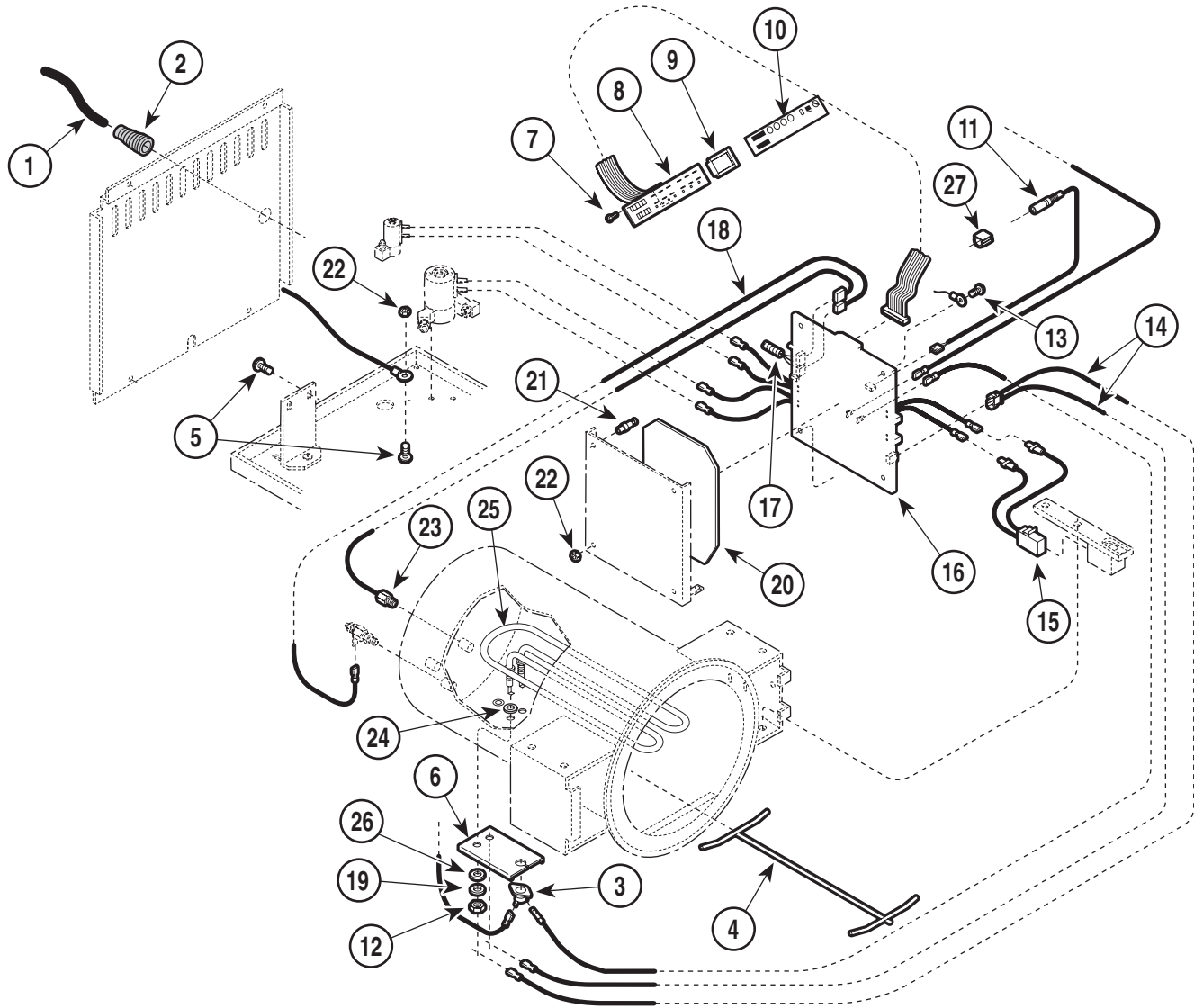

MA442901

Used on Units with Serial Numbers: FF1055 and FG1138 - thru Present

Item	Part No.	Description	Qty.	Item	Part No.	Description	Qty.
1		Cordset (Refer to Wiring Diagram)	1	15	002-0362-00	Switch Assembly	1
2	015-1137-00	Strain Relief Bushing	1	16		Control PC Board (Refer to "Control PC Board" Elsewhere)	Ref
3	002-0370-00	Thermostat	1	17	015-0257-02	Flex Guard Tubing	1
4	057-0425-00	Spacer Assembly	1	18	015-0654-00	Chamber Level Sensor Harness	1
5	040-0010-75	Screw	1	19	045-0001-56	Lockwasher	2
6	H225617	Bracket	1	20	053-0455-00	Insulator	1
7	040-0006-04	Screw	6	21	053-0295-01	Standoff	3
8	002-0369-02	Display PC Board	1	22	041-0010-04	Locknut	1
9	053-0454-00	Display Gasket	1	23	002-0357-00	Temperature Probe Assembly	1
10	061-0531-00	Display Overlay	1	24	H98137	Gasket	2
11		PCB/Printer Harness (Refer to "Printer Components" Elsewhere)	1	25	002-0367-00	Heat Element (Includes Item 24)	1
12	H97949	Nut	2	26	H97971	Washer	2
13	040-0010-46	Screw	1	27	015-1395-00	Tubing Flex Guard	1
14	015-0657-00	PCB/Heater Harness	1				

Always Specify Model & Serial Number

M9 / M9D Control PC Board

SECTION VI PARTS LIST M9 / M9D

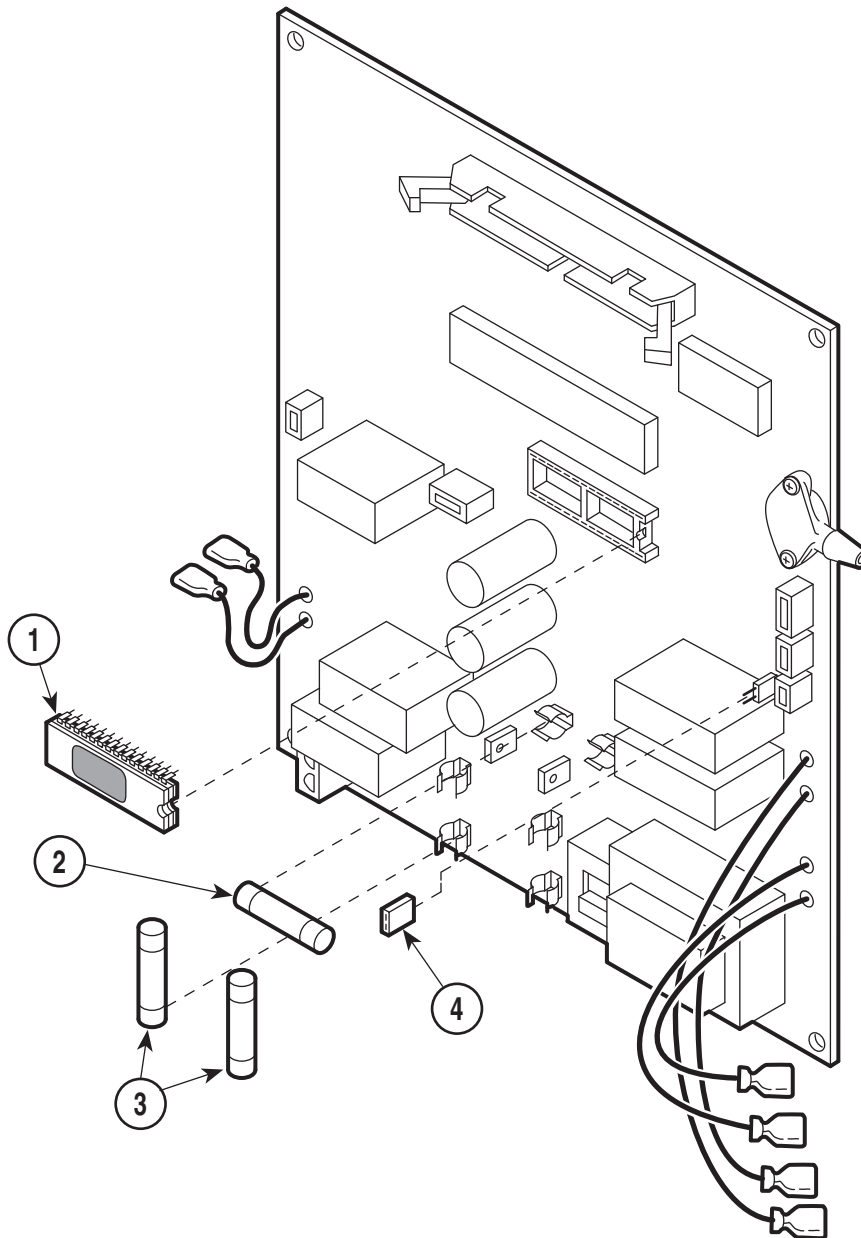

ATTENTION

Control PC board is no longer available.

Please contact Midmark Technical Service for information about the PC board rebate program.

(Some restrictions may apply)

MA2220-01

Item	Part No.	Description	Qty.	Item	Part No.	Description	Qty.
		Control PC Board {115 V Domestic} (Includes Item 1 thru 3)	1	3	• 015-0346-07	• Line Fuse (15 amp/250 V) {Used on 115 V Domestic Units Only}	2
		Control PC Board {230 V Export} (Includes Item 1 thru 3)	1		• 015-0346-11	• Line Fuse (8 amp/250 V) {Used on 230 V Export Units Only}	2
		Control PC Board {100 V Export} (Includes Item 1 thru 4)	1		• 015-0346-06	• Line Fuse (20 amp/250 V) {Used on 100 V Export Units Only}	2
1		• M9 EPROM	Ref	4	• 015-0880-00	• 2 Position Jumper {Used on 230 V & 100 V Export Units Only}	1
2	• 015-0346-08	• Printer Fuse (3 amp/250 V)	1				

Always Specify Model & Serial Number

M9 Labels and Decals

SECTION VI PARTS LIST M9 / M9D

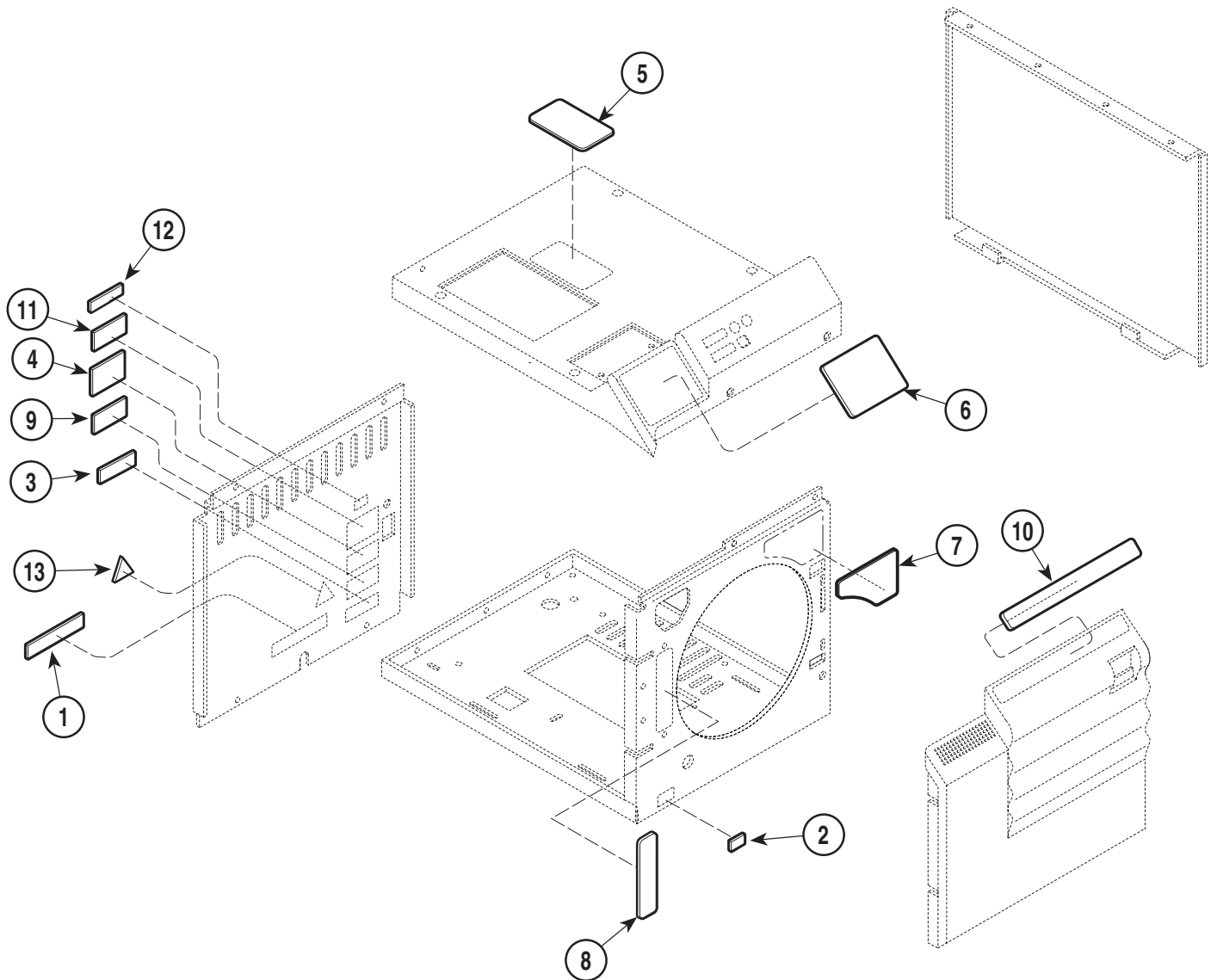

MA202513

Item	Part No.	Description	Qty.	Item	Part No.	Description	Qty.
1	061-0203-00	Label - Electrical Shock (English)	1	7	061-0726-00	Label - Hot Surface	1
	061-0516-00	Label - Electrical Shock (French)	1	8	061-0311-00	Label - Water Level	1
	061-0600-00	Label - Electrical Shock (Portuguese)	1	9	061-0624-00	UL / CUL 507U Label (Used on select units only)	1
2		Label - Serial Number (Front)	1	10	061-0441-00	Label - Operation (English)	1
3	061-0477-00	Label - Patent	1		061-0441-18	Label - Operation (Polish)	1
4		Label - Serial Number (Rear)	1		061-0513-00	Label - Operation (French)	1
5	061-0309-00	Label - Warning, P.R. Valve (English)	1		061-0596-00	Label - Operation (Portuguese)	1
	061-0514-00	Label - Warning, P.R. Valve (French)	1	11	061-0782-00	CE Representative Label (Used on select units only)	1
	061-0597-00	Label - Warning, P.R. Valve (Portuguese) ..	1	12	061-0733-00	CE Label (Used on select units only)	1
	061-0704-18	Label - Warning, P.R. Valve (Polish)	1	13	061-0654-01	Label - Caution (Select units only)	1
6	061-0381-00	Label - Warning (English)	1	14	004-0068-00	Laminated Instruction Sheet (Not Shown) ..	1
	061-0512-00	Label - Warning (French)	1	15	004-0254-00	Quick Reference Sheet (Not Shown)	1
	061-0595-00	Label - Warning (Portuguese)	1				
	061-0381-18	Label - Warning (Polish)	1				

Always Specify Model & Serial Number

M9D Labels and Decals

SECTION VI PARTS LIST M9 / M9D

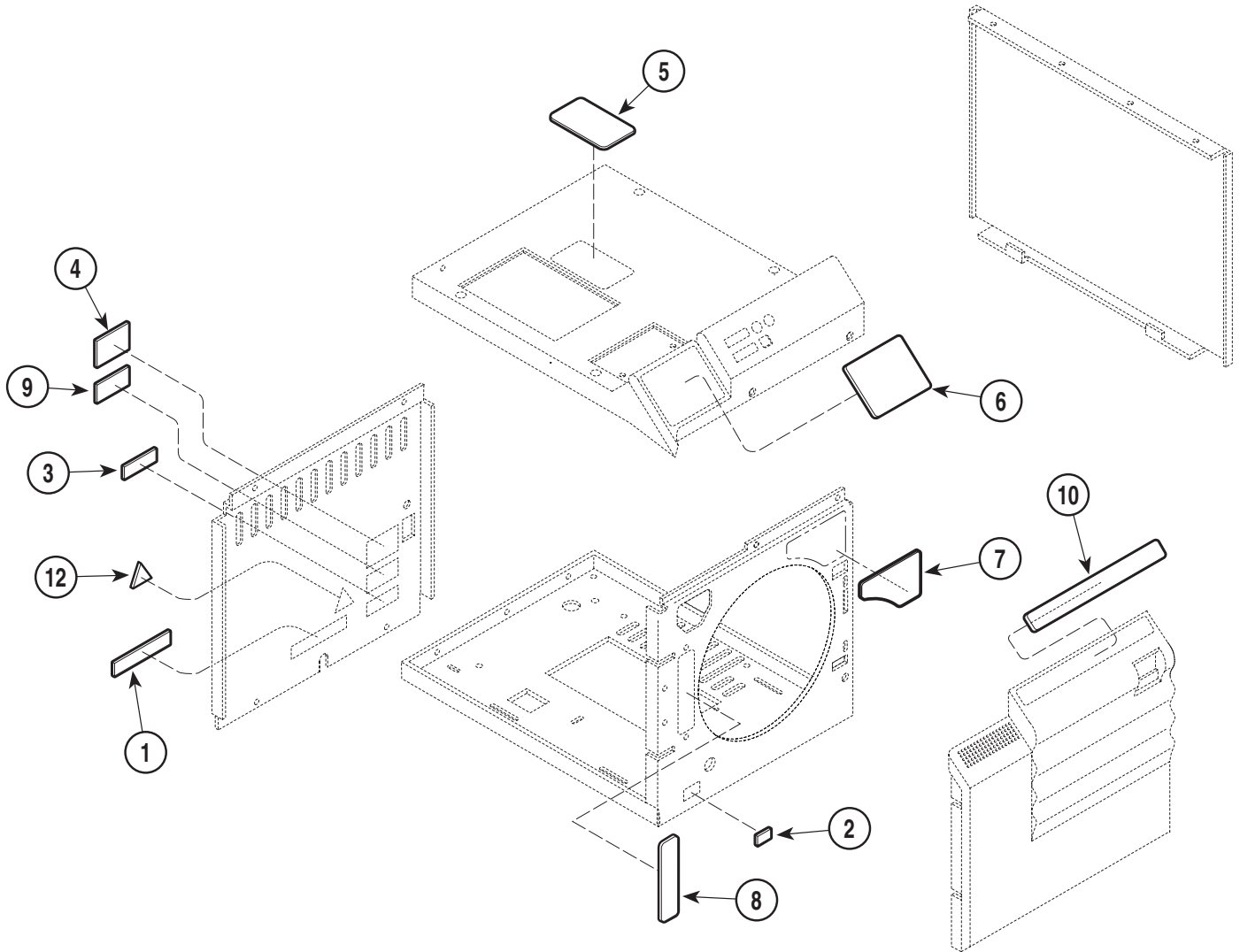

MA443101

Item	Part No.	Description	Qty.	Item	Part No.	Description	Qty.
1	061-0203-00	Label - Electrical Shock	1	9	061-0624-00	UL / CUL 507U Label	1
2		Label - Patent (Front)	1	10	061-0533-00	Label - Operation	1
3	061-0477-00	Label - Patent (Rear)	1	11	061-0534-00	Sterilizer Label Set (Not Shown Includes Items 5, 6 & 10)	1
4		Label - Serial Number	1	12	061-0654-00	Label - Caution	1
5	061-0309-01	Label - Warning, P.R. Valve	1	13	004-0068-00	Laminated Instruction Sheet (Not Shown)	1
6	061-0532-00	Label - Warning	1	14	004-0254-00	Quick Reference Sheet (Not Shown)	1
7	061-0591-00	Label - Hot Surface	1				
8	061-0311-00	Label - Water Level	1				

Always Specify Model & Serial Number

Printer Components

SECTION VI PARTS LIST M9 / M9D

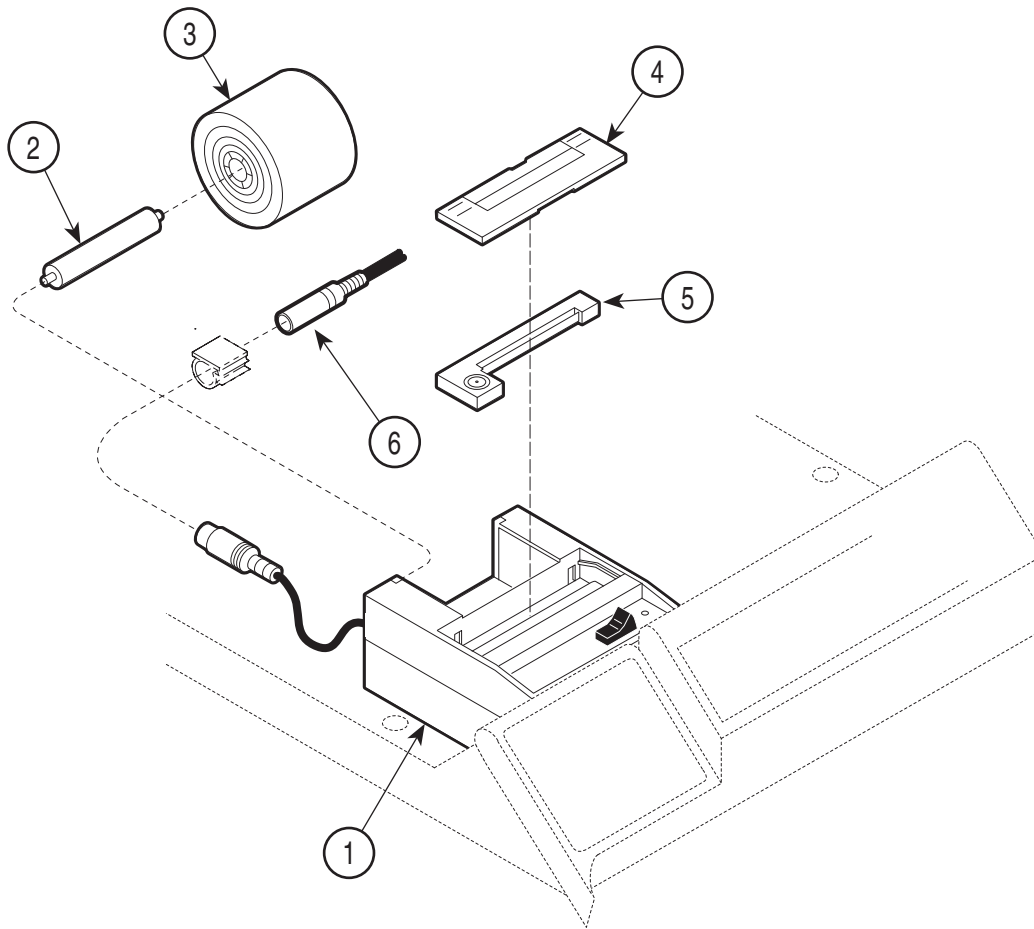

MA203302

Item	Part No.	Description	Qty.	Item	Part No.	Description	Qty.
1	9A155001	Accessory Printer (Incl. Items 2 thru 6)	1	5	• 053-0505-00	• Printer Cartridge	1
2	• 053-0506-00	• Arbor	1	6	• 015-0978-00	• Printer Wiring Harness	1
3	• 060-0008-00	• Paper Roll	1	7	002-0371-00	Cartridge/Paper Kit (Includes Two	
4	• 053-0507-00	• Cover	1			Rolls of Paper and One Cartridge	1

Always Specify Model & Serial Number

Racks, Trays, and Cleaner

SECTION VI PARTS LIST M9 / M9D

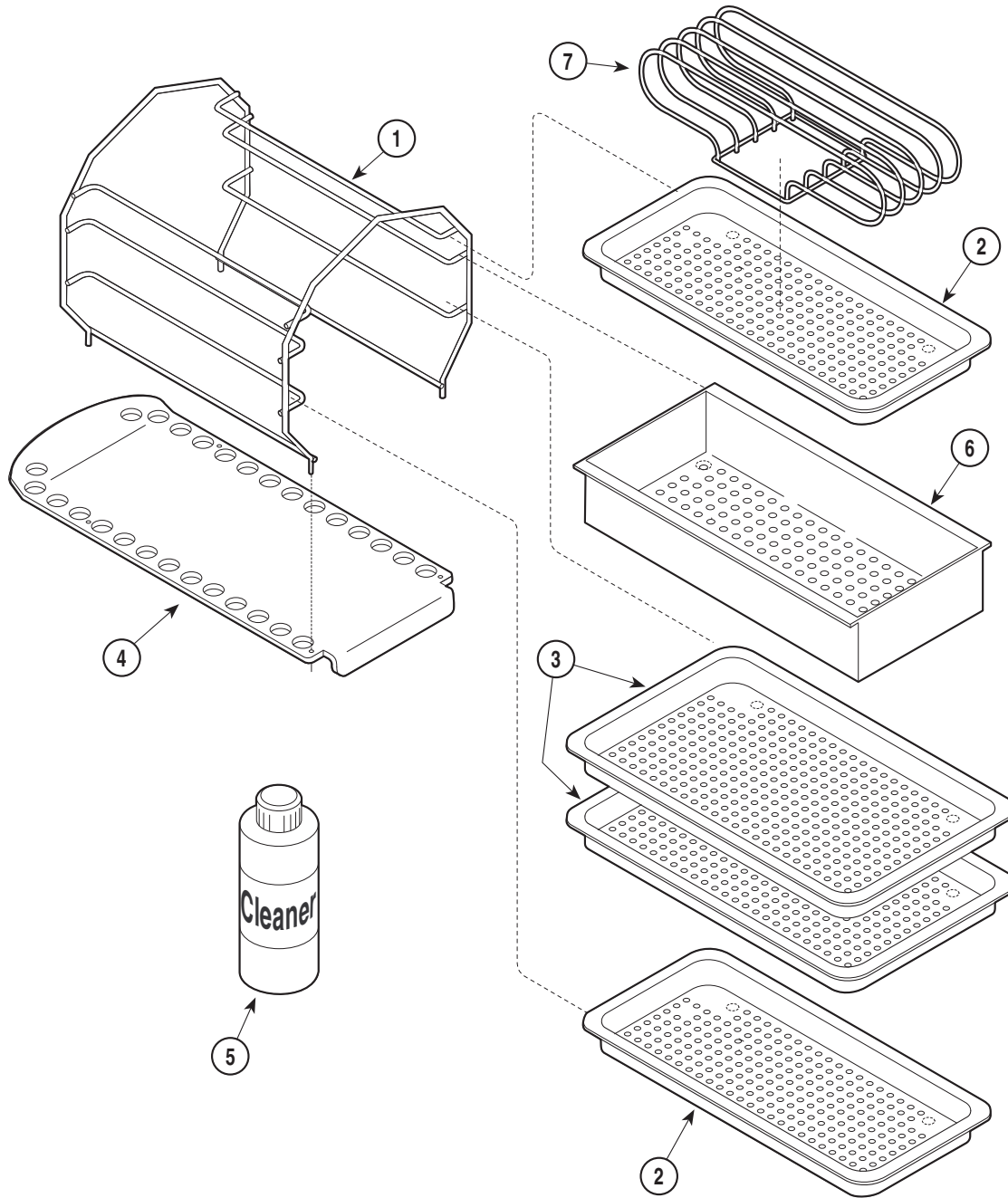

MA203201

Used on Units with Serial Numbers:

CZ1000 thru CZ4334
DY1000 thru DY1176
FK1000 thru FK1699

DA1000 thru DA1004
FD1000 thru FD1399
FL1000 thru FL1474

DB1000 thru DB1237
FF1000 thru FF1034
OM1000 thru OM14524

DX1000 thru DX2555
FG1000 thru FG1112

Item	Part No.	Description	Qty.	Item	Part No.	Description	Qty.
1	030-0710-01	Wire Tray Rack	1			Case with M.S.D. Sheet)	AR
2	002-0253-00	5" Tray	2		002-0396-00	Sterilizer Cleaner-Midmark (Single Bottle with M.S.D. Sheet)	AR
3	002-0374-00	7" Tray	2		002-0396-01	Sterilizer Cleaner-Midmark (12 Bottle Case with M.S.D. Sheet)	AR
4	050-1773-00	Tray Plate	1	6	9A224001	Sterilizer Deep Tray	1
5	002-0269-00	Sterilizer Cleaner-Ritter (Single Bottle with M.S.D. Sheet)	AR	7	9A226001	Sterilizer Pouch Rack	1
	002-0269-01	Sterilizer Cleaner-Ritter (12 Bottle					

Always Specify Model & Serial Number

Racks, Trays, and Cleaner

SECTION VI PARTS LIST M9 / M9D

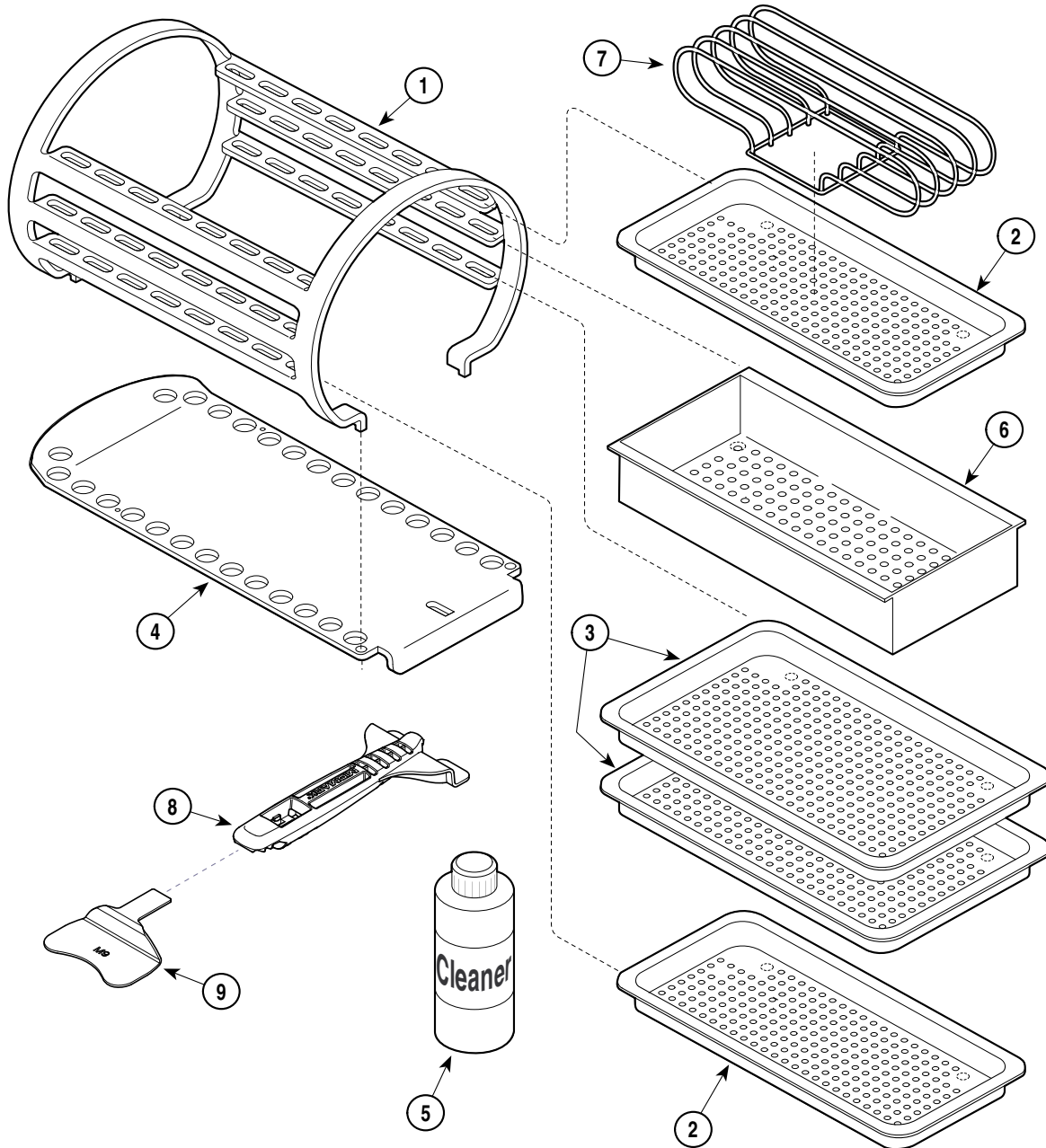

MA376302i

Used on units with Serial Numbers:
CZ4335, DA1005, DB1238, DX2556, DY1177, FD1400, FF1035,
FG1113, FK1700, FL1475, LA1000, OM14525 - thru Present

Item	Part No.	Description	Qty.	Item	Part No.	Description	Qty.
1	050-3691-00	Wire Tray Rack	1	002-0396-01	Sterilizer Cleaner-Midmark ([12] 16 oz. Bottle Case with M.S.D. Sheet)	AR	
2	002-0253-00	5" Tray	2	002-0396-03	Sterilizer Cleaner-EMS ([32] 16 oz. Bottle Case with M.S.D. Sheet)	AR	
3	002-0374-00	7" Tray	2	6	9A224001	Sterilizer Deep Tray	1
4	050-3750-00	Tray Plate	1	7	9A226001	Sterilizer Pouch Rack	1
5	002-0269-00	Sterilizer Cleaner-Ritter (Single Bottle with M.S.D.Sheet)	AR	8	053-1038-00	Tray/Cassette Tool	1
	002-0269-01	Sterilizer Cleaner-Ritter (12 Bottle Case with M.S.D.Sheet)	AR	9	050-4662-02	M9 Tray Plate	1
	002-0396-00	Sterilizer Cleaner-Midmark (Single Bottle with M.S.D.Sheet)	AR				

Always Specify Model & Serial Number

Packaging

SECTION VI PARTS LIST M9 / M9D

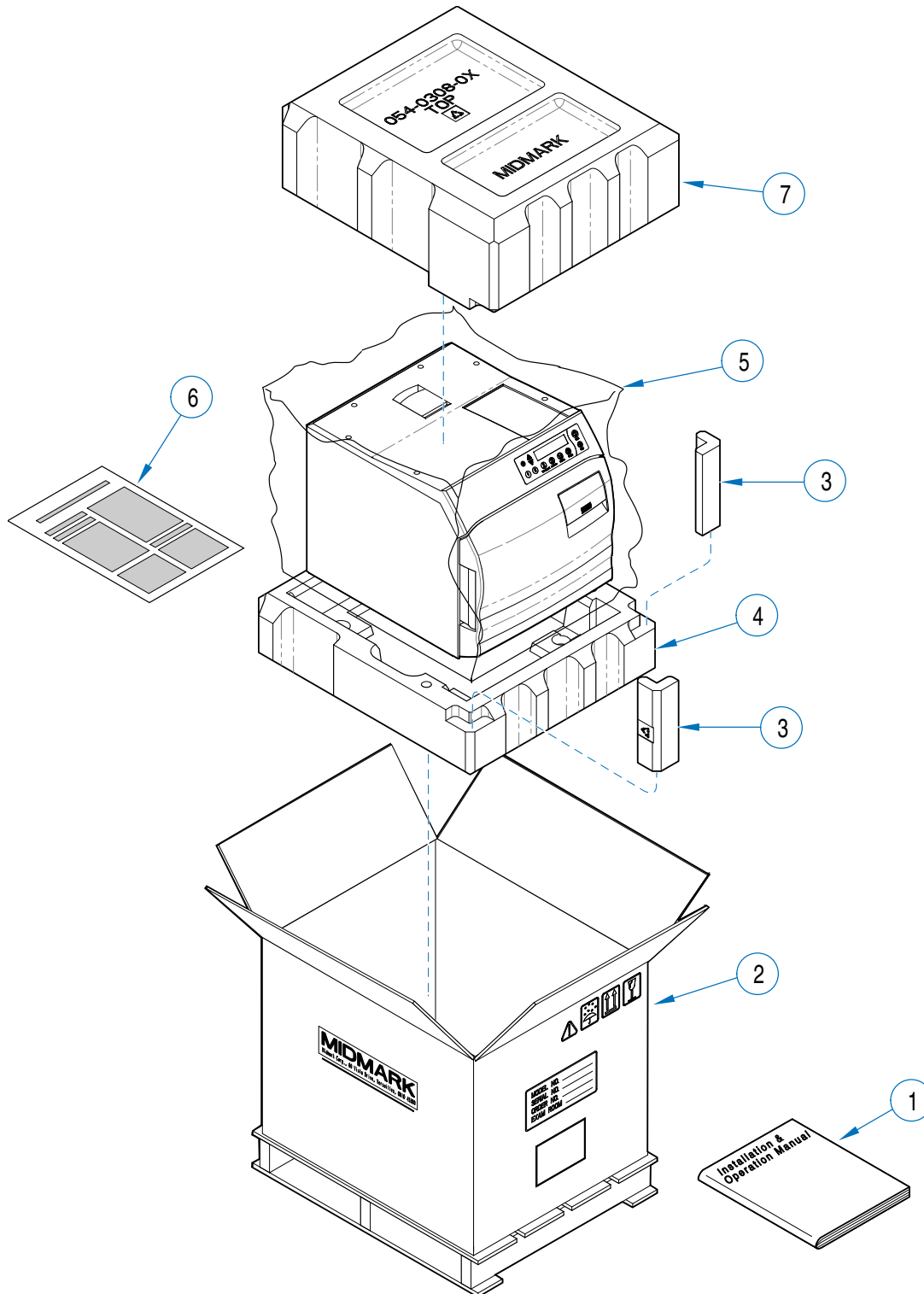

MA202406

Item	Part No.	Description	Qty.	Item	Part No.	Description	Qty.
1	003-1031-00	M9 Installation & Operation Manual (English)	1	3	054-0309-00	Corner Pad	2
	003-1033-00	M9D Installation & Operation Manual (English)	1	4	054-0308-00	Bottom Pad	1
	003-0920-02	M9 Installation & Operation Manual (French)	1	5	053-0061-01	Poly Bag	1
	003-0920-18	M9 Installation & Operation Manual (Polish)	1	6	077-0033-00	Speed Clean Material Data Sheet	1
2	066-0721-00	Slotted Carton	1	7	054-0310-00	Top Pad	1
				8	002-0532-00	Ritter M9 Packaging Kit (Includes Items 2, 3, 4, 5 & 7)	1
					002-0532-01	Midmark M9 Packaging Kit (Includes Items 2, 3, 4, 5 & 7)	1

Always Specify Model & Serial Number

(blank page)

**SECTION VI
PARTS LIST**

Attention!

The Parts Lists in this manual are separated as shown below .
Verify model number, then refer to appropriate pages.

M9 / M9D Pages 6-2 thru 6-16

M11 / M11D Pages 6-17 thru 6-31

M11 Component / Page Cross-Reference

SECTION VI PARTS LIST M11 / M11D

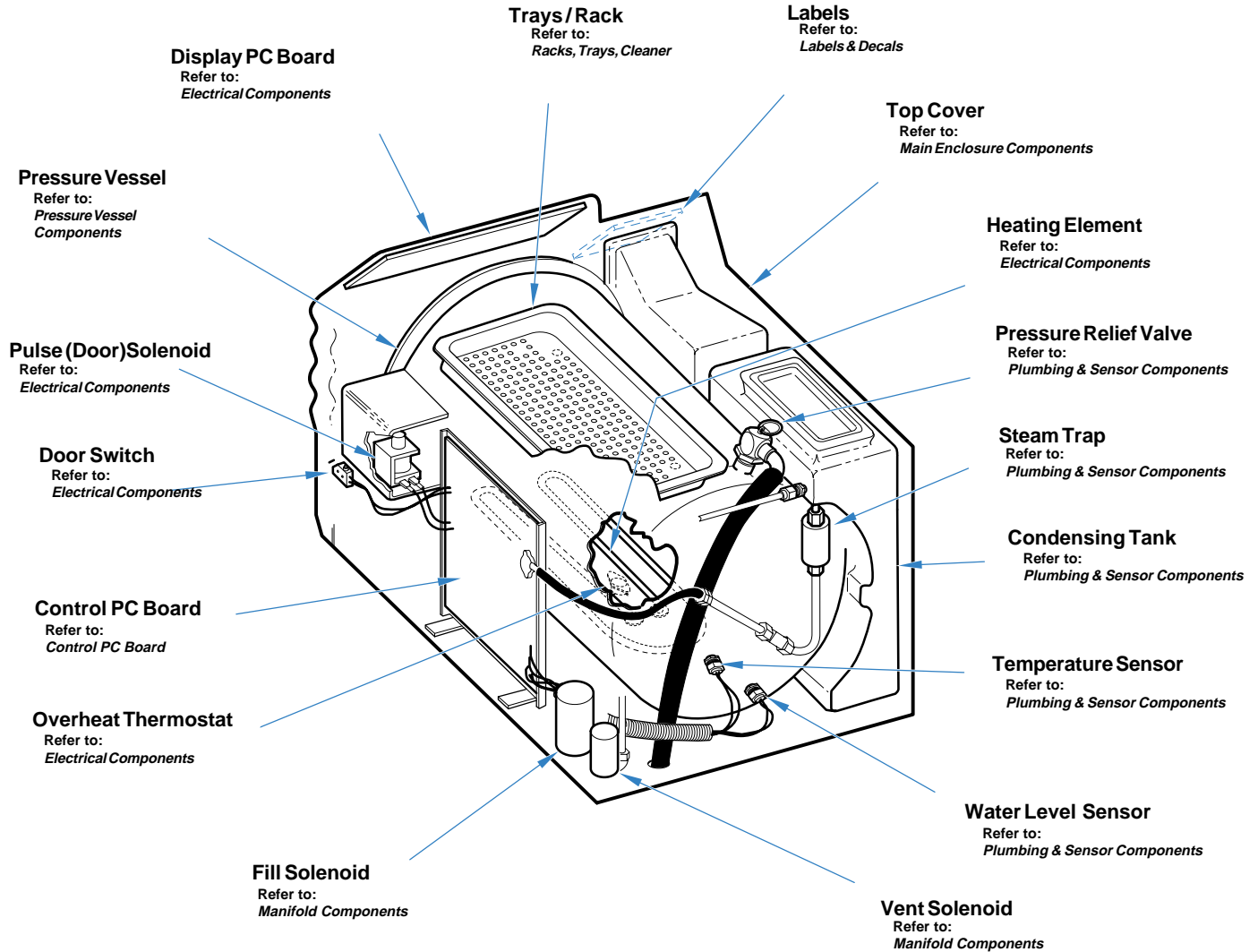

MA

Item	Model No.	Description	Page	Item	Model No.	Description	Page
	M11-001	Ritter M11 Ultraclave (120VAC) [serial number prefix "ES"].....	6-17		M11-004	Midmark M11 Ultraclave (230 VAC) [serial number prefix "FR"].....	6-17
	M11-002	Midmark M11 Ultraclave (120VAC) [serial number prefix "ET"].....	6-17		M11-005	EMS M11 Ultraclave (230 VAC) [serial number prefix "GB"].....	6-17
	M11-003	Ritter M11 Ultraclave (230 VAC) [serial number prefix "FP"].....	6-17		M11-006	M11 Ultraclave - UK (230VAC, CE) [serial number prefix "NP"].....	6-17

Always Specify Model & Serial Number

M11D Component / Page Cross-Reference

SECTION VI PARTS LIST M11 / M11D

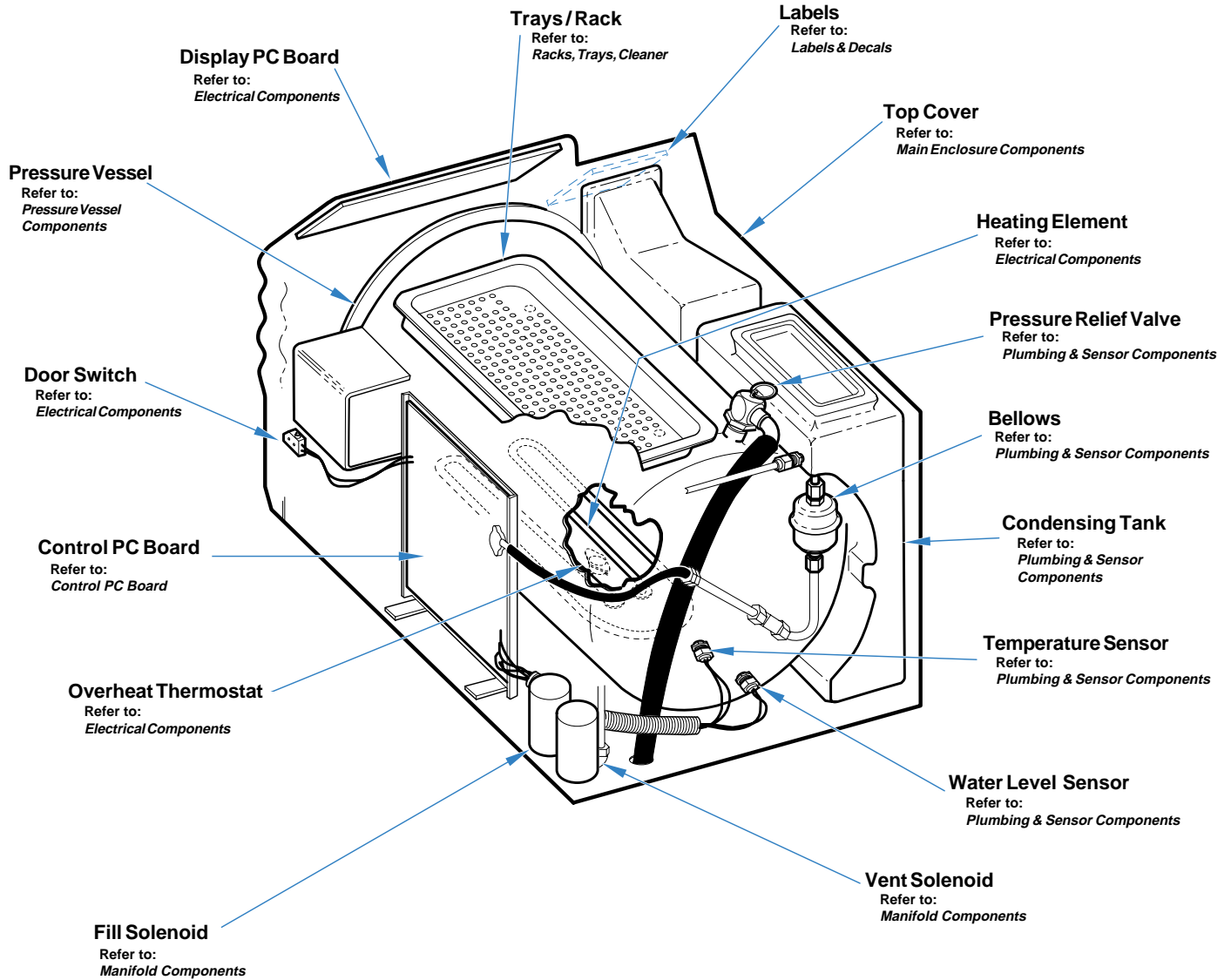

MA600800i

Item	Model No.	Description	Page	Item	Model No.	Description	Page
	M11D-001	Ritter M11D Ultraclave (120 VAC [serial number prefix "GC"].....	6-18		M11D-002	Midmark M11D Ultraclave (120 VAC) [serial number prefix "GD"].....	6-18

Always Specify Model & Serial Number

Main Enclosure Components

SECTION VI PARTS LIST M11 / M11D

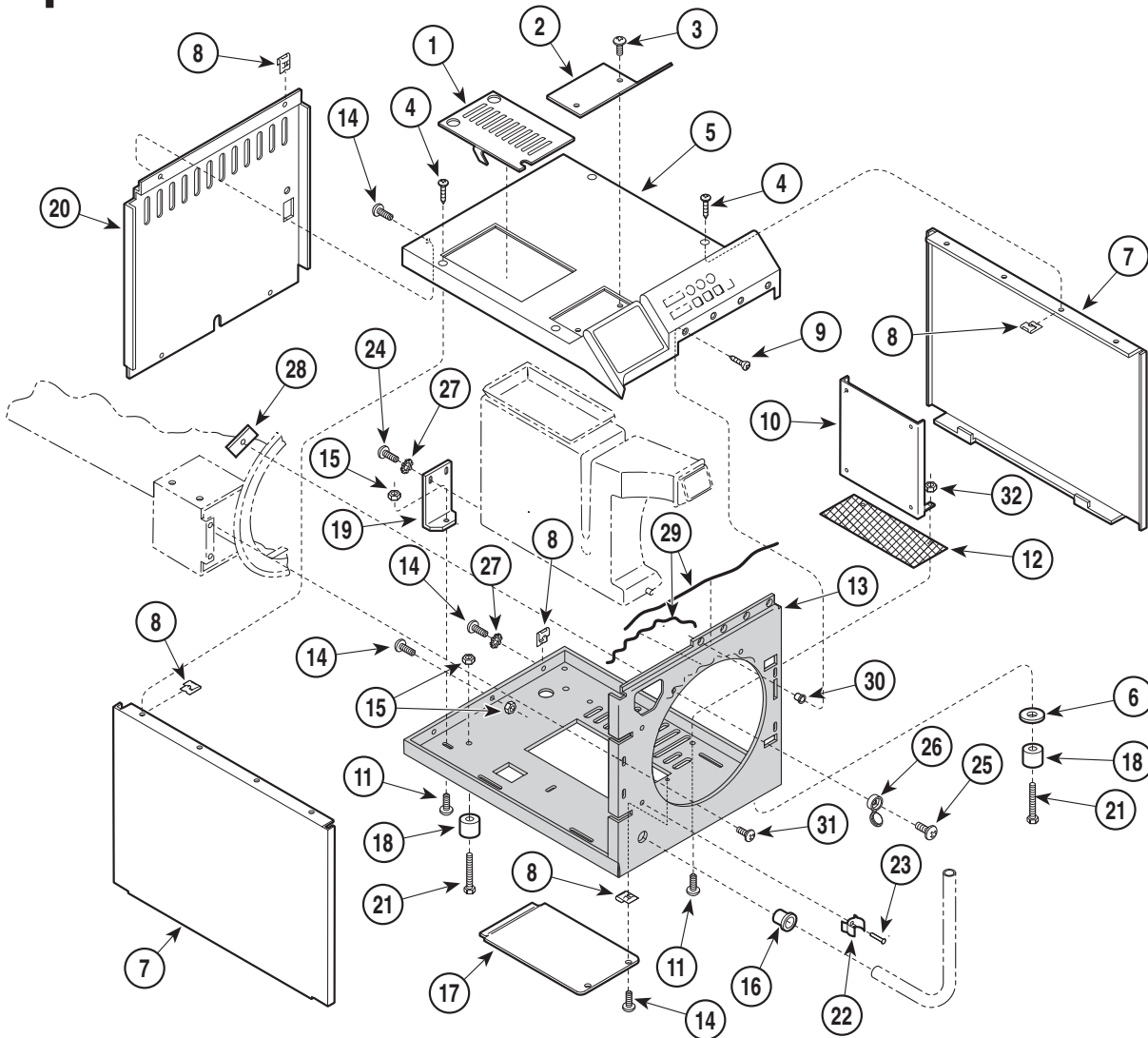

MA225405

Used on units with Serial Numbers:
ES1347 thru ES3020 **ET1095 thru ET3317**
GC1000 thru GC1018 **GD1000 thru GD1015**

Item	Part No.	Description	Qty.	Item	Part No.	Description	Qty.
1	030-1117-00	Top Inspection Cover	1	16	053-0068-11	Snap Bushing	1
2	050-2638-00	Cover Plate - Printer	1	17	050-4326-01	Base Inspection Cover	1
3	040-0008-87	Screw	2	18	002-0963-00	Leveler Foot	4
4	040-0010-88	Screw	4	19	050-1778-00	Condensing Tank Bracket	1
5		Top Cover Assembly Kit (includes all Decals and Display Gasket)		20	050-2587-00	Back Panel	1
	002-0503-00	M11	1	21	040-0010-44	Screw	4
	002-0503-01	M11D	1	22	053-0388-01	Hose Clip	2
6	045-0001-00	Washer	AR	23	042-0010-11	Pop Rivet	2
7	050-2589-00	Side Panel	2	24	040-0010-74	Screw	2
8	H352623	Tinnerman Clip	11	25	040-0010-124	Screw	2
9	040-0010-112	Screw	4	26	053-0723-00	Screw Cover	2
10	050-3996-00	Control PCB Bracket	1	27	045-0001-31	Lockwasher	3
11	040-0010-75	Screw	3	28	050-4750-00	Flange Clamp	2
12	016-0428-04	Screen	1	29	042-0021-00	Adhesive	AR
13	050-2588-00	Base	1	30	042-0045-01	Nutsert	4
14	040-0010-125	Screw	6	31	040-0010-95	Screw	4
15	041-0010-02	Nut	6	32	041-0010-04	Nut - w/Starwasher	2

Always Specify Model & Serial Number

Main Enclosure Components

SECTION VI PARTS LIST M11 / M11D

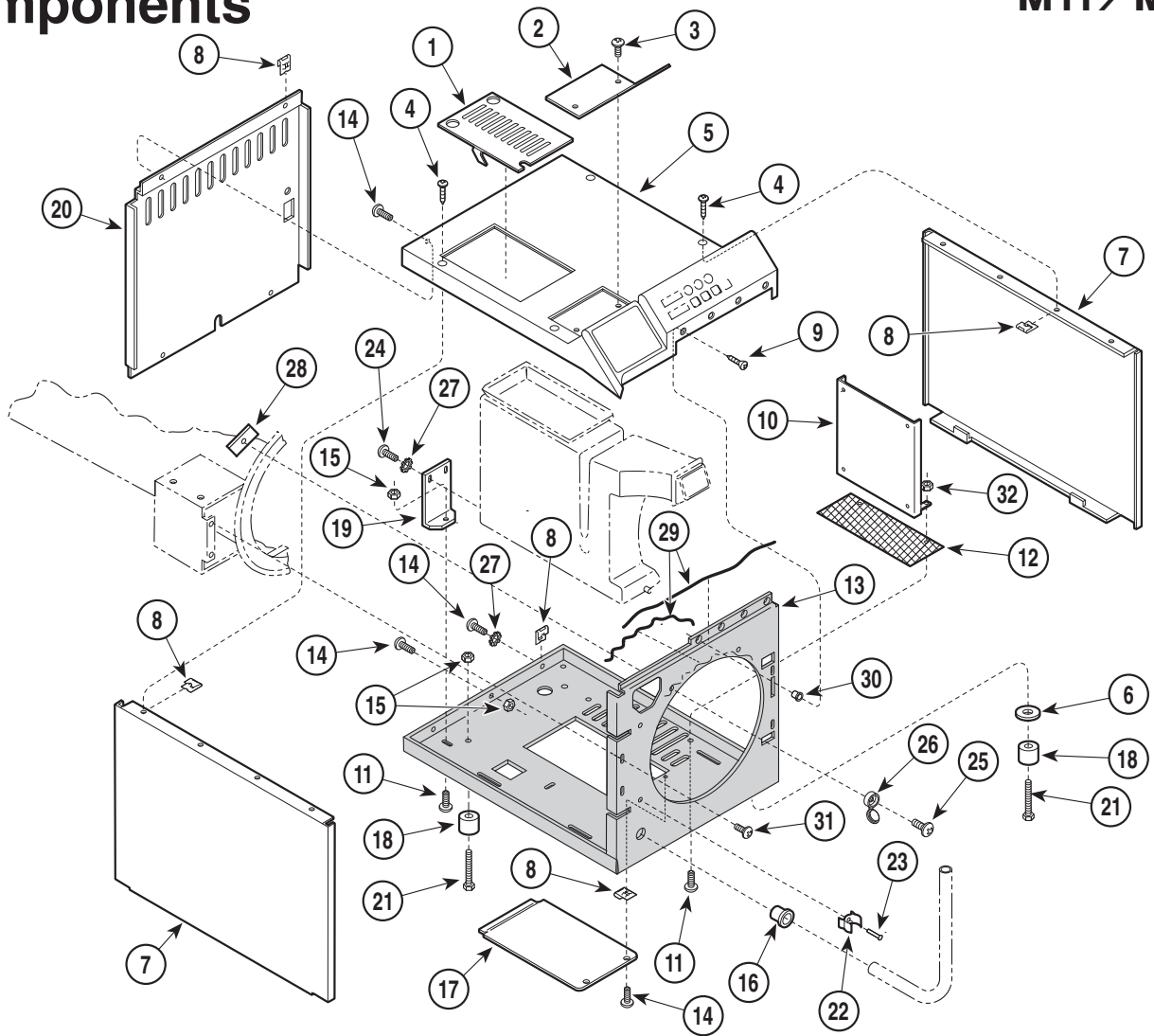

MA225405

Used on units with Serial Numbers:

ES3021 thru ES3376
FR1000 thru FR1100

ET3318 thru ET3893
GB1000 thru GB1044

FP1000 thru FP1063
GC1019 thru GC1020

Item	Part No.	Description	Qty.	Item	Part No.	Description	Qty.
1	030-1117-00	Top Inspection Cover	1	15	041-0010-02	Nut	6
2	050-2638-00	Cover Plate - Printer	1	16	053-0068-11	Snap Bushing	1
3	040-0008-87	Screw	2	17	050-4326-01	Base Inspection Cover	1
4	040-0010-88	Screw	4	18	002-0963-00	Leveler Foot	4
5		Top Cover Assembly Kit (Incls. all Decals and Display Overlay)		19	050-1778-00	Condensing Tank Bracket	1
	002-0503-00	M11	1	20	050-2587-00	Back Panel (230 V. units only)	1
	002-0503-01	M11D	1		050-2587-01	Back Panel (120 V. units only)	1
	002-0503-02	M11 (w/ metric display overlay)	1	21	040-0010-44	Screw	4
	002-0503-03	M11 (w/ French display overlay)	1	22	053-0388-01	Hose Clip	2
6	045-0001-00	Washer	AR	23	042-0010-11	Pop Rivet	2
7	050-2589-00	Side Panel	2	24	040-0010-74	Screw	2
8	H352623	Tinnerman Clip	11	25	040-0010-124	Screw	2
9	040-0010-112	Screw	4	26	053-0723-00	Screw Cover	2
10	050-3996-00	Control PCB Bracket	1	27	045-0001-31	Lockwasher	3
11	040-0010-75	Screw	3	28	050-4750-00	Flange Clamp	2
12	016-0428-04	Screen	1	29	042-0021-00	Adhesive	AR
13	050-2588-00	Base	1	30	042-0045-01	Nutsert	4
14	040-0010-125	Screw	6	31	040-0010-95	Screw	4
				32	041-0010-04	Nut - w/Starwasher	2

Always Specify Model & Serial Number

Main Enclosure Components

SECTION VI PARTS LIST M11 / M11D

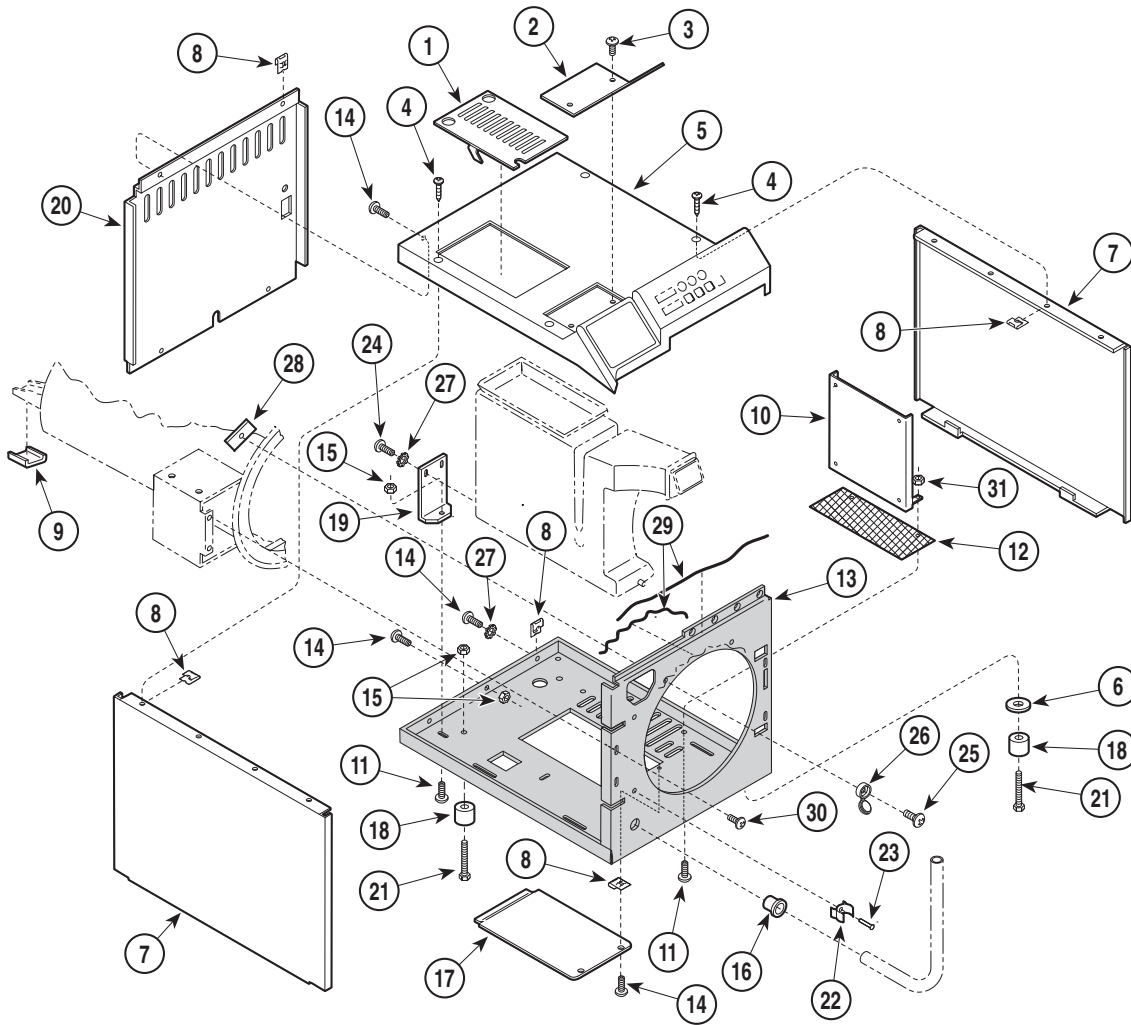

MA225406

Used on units with Serial Numbers:

ES3377 thru ES4879
GB1043 thru GB1109

ET3319 thru ET6315
GC1020 thru GC1074

FP1064 thru FP6315
GD1016 thru GD1064

FR1101 thru FR1203

Item	Part No.	Description	Qty.	Item	Part No.	Description	Qty.
1	030-1117-00	Top Inspection Cover	1	15	041-0010-02	Nut	6
2	050-2638-00	Cover Plate - Printer	1	16	053-0068-11	Snap Bushing	1
3	040-0008-87	Screw	2	17	050-4326-01	Base Inspection Cover	1
4	040-0010-88	Screw	4	18	002-0963-00	Leveler Foot	4
5		Top Cover Assembly Kit (incls. all decals and display overlay)		19	050-1778-00	Condensing Tank Bracket	1
	002-0503-00	M11	1	20	050-2587-01	Back Panel (120 V. units only)	1
	002-0503-01	M11D	1		050-2587-00	Back Panel (230 V. units only)	1
	002-0503-02	M11 (w/ metric display overlay)	1	21	040-0010-44	Screw	4
	002-0503-03	M11 (w/ French display overlay)	1	22	053-0388-01	Hose Clip	2
6	053-0923-00	Washer (Used on Early Units Only)	2	23	042-0010-11	Pop Rivet	2
7	050-2589-00	Side Panel	2	24	040-0010-74	Screw	2
8	H352623	Tinnerman Clip	11	25	040-0010-124	Screw	2
9	050-3987-00	Spacer	1	26	053-0723-00	Screw Cover	2
10	050-3996-00	Control PCB Bracket	1	27	045-0001-31	Lockwasher	3
11	040-0010-75	Screw	3	28	050-4750-00	Flange Clamp	2
12	016-0428-04	Screen	1	29	042-0021-00	Adhesive	AR
13	050-2588-00	Base	1	30	040-0010-95	Screw	4
14	040-0010-125	Screw	6	31	041-0010-04	Nut - w/Starwasher	2

Always Specify Model & Serial Number

Main Enclosure Components

SECTION VI PARTS LIST M11 / M11D

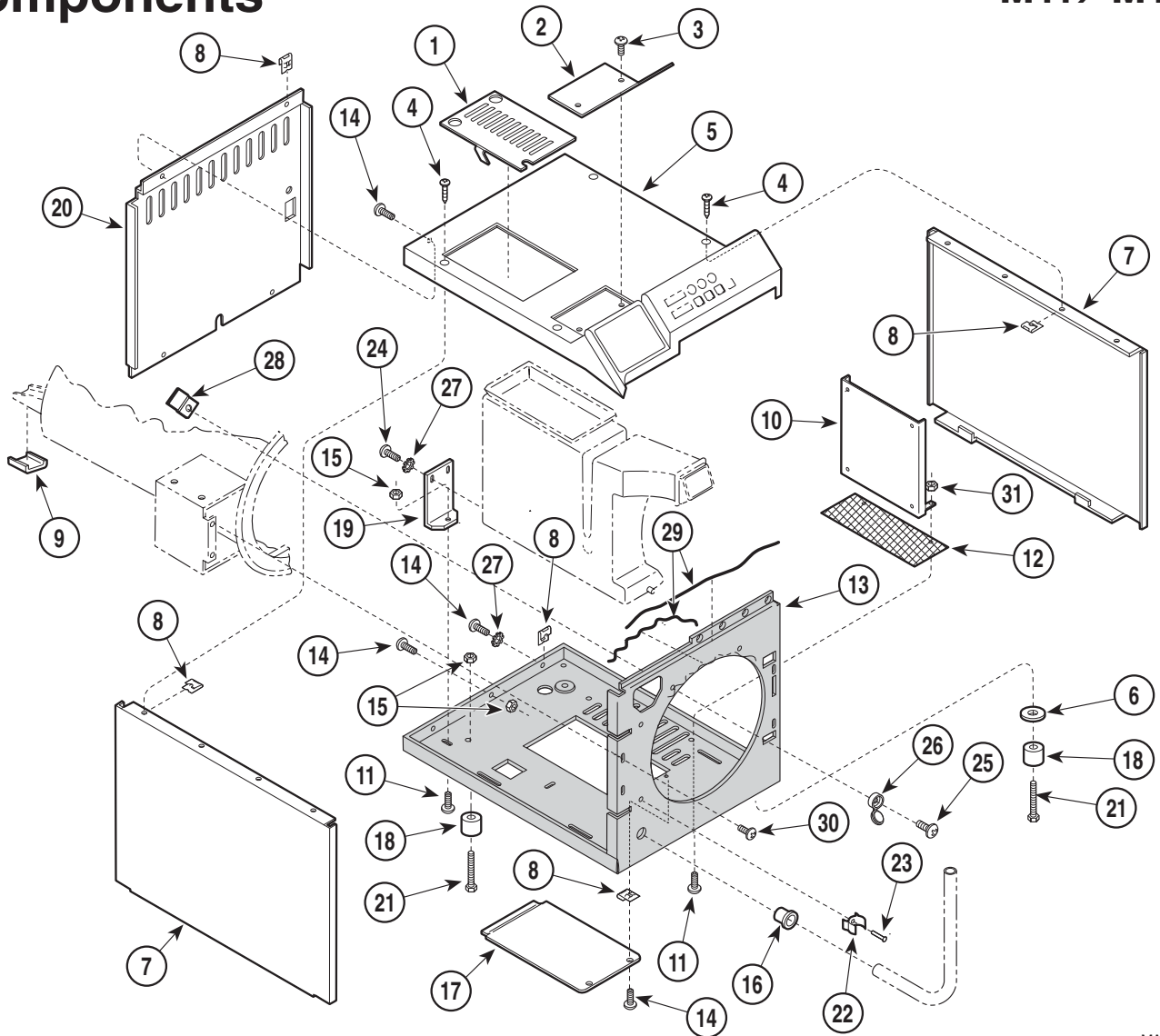

MA225408

Used on units with Serial Numbers:

ES4880, ET6316, FP6316, FR1204, GB1110, GC1075, GD1065, NP1000 - thru Present

Item	Part No.	Description	Qty.	Item	Part No.	Description	Qty.
1	030-1117-00	Top Inspection Cover	1	15	041-0010-02	Nut	5
2	050-2638-00	Cover Plate - Printer	1	16	053-0068-11	Snap Bushing	1
3	040-0008-50	Screw	2	17	050-4326-00	Base Inspection Cover	1
4	040-0010-88	Screw	4	18	002-0963-00	Leveler Foot	4
5		Top Cover Assembly Kit (incls. all decals and display overlay)		19	050-1778-00	Condensing Tank Bracket	1
	002-0503-00	M11	1	20	050-3860-00	Back Panel (230 V. units only)	1
	002-0503-01	M11D	1		050-3860-01	Back Panel (120 V. units only)	1
	002-0503-02	M11 (w/ metric display overlay)	1	21	040-0010-44	Screw	4
	002-0503-03	M11 (w/ French display overlay)	1	22	053-0388-01	Hose Clip	2
6	053-0923-00	Washer (Used on Early Units Only)	2	23	042-0010-11	Pop Rivet	2
7	050-2589-00	Side Panel	2	24	040-0010-74	Screw	2
8	H352623	Tinnerman Clip	11	25	040-0010-124	Screw	2
9	050-3987-00	Spacer	1	26	053-0723-00	Screw Cover	2
10	050-3996-00	Control PCB Bracket	1	27	045-0001-31	Lockwasher	3
11	040-0010-75	Screw	3	28	050-4750-00	Flange Clamp	2
12	016-0428-04	Screen	1	29	042-0021-00	Adhesive	AR
13	050-4722-00	Base	1	30	040-0010-95	Screw	5
14	040-0010-125	Screw	6	31	041-0010-04	Nut - w/Starwasher	2

Always Specify Model & Serial Number

Plumbing & Sensor Components

SECTION VI PARTS LIST M11 / M11D

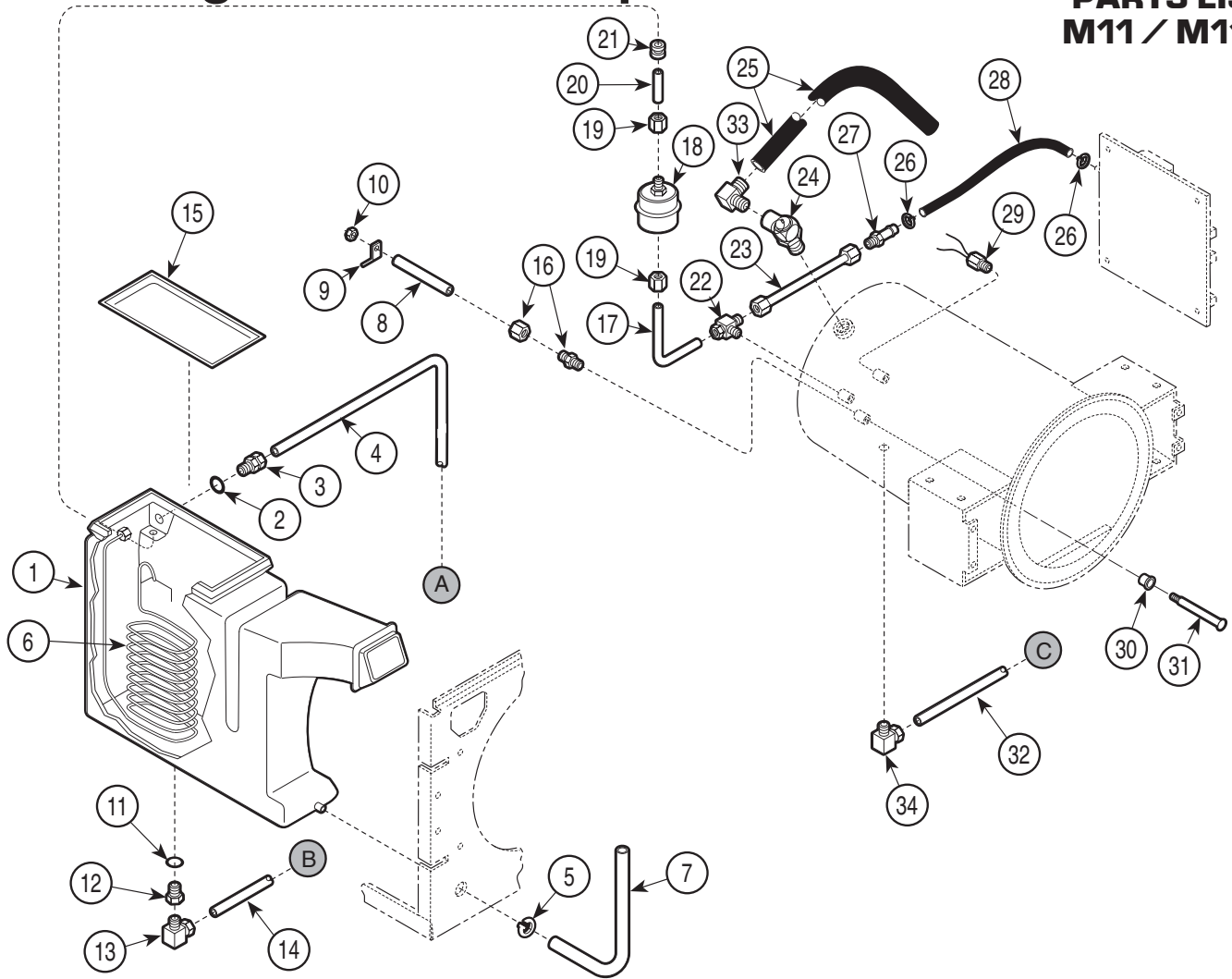

MA201915

Used on units with Serial Numbers:

ES1000 thru ES4300
GB1000 thru GB1094

ET1000 thru ET5399
GC1000 thru GC1035

FP1000 thru FP1072
GD1000 thru GD1049

FR1000 thru FR1177

Item	Part No.	Description	Qty.	Item	Part No.	Description	Qty.
1	053-0580-00	Condensing Tank (Includes Item 15)	1	19	014-0392-00	Compression Nut (Refer to Kit [*])	2
2	H98137	Gasket	1	20	014-0208-00	Tube	1
3	014-0216-00	Bulkhead Union	1	21	053-0394-01	Grommet	1
	014-0392-00	Compression Nut Only	AR	22	014-0202-00	Male Branch Tee	1
4	014-0251-00	Tube (M11)	1	23	014-0207-00	PCB Pres. Sensor Tube (Refer to Kit [*])	1
	014-0279-00	Tube (M11D)	1	24	002-0359-00	Pressure Relief Valve - 35 PSI (Apply Teflon Tape)	
5	016-0748-01	Nylon Hose Clamp	1			(Includes Elbow, Item 35)	1
6	052-0173-00	Condensing Coil	1	25	053-0613-02	Tube - Pressure Relief	1
7	053-0391-01	Hose	1	26	015-0013-05	Cable Tie (High Temp)	2
8	002-0358-00	Level Sensor Tube (Includes items 9,10,16,30,31)	1	27	014-0217-00	Compression Connector (Refer to Kit [*])	1
9	015-0595-00	Terminal	1	28	053-0404-02	Tube-PCB Connector (Refer to Kit [*]) ...	1
10	041-0006-02	Locknut	1	29	002-0357-00	Temperature Probe Assembly (Apply Teflon Tape)	1
11	053-0393-00	O-ring	1	30	053-0407-00	Spacer	1
12	014-0209-00	Bulkhead Couple	1	31	030-0858-00	Level Sensor Assembly	1
13	014-0184-01	Male Elbow	1	32	014-0250-00	Tube	1
14	014-0255-00	Tube	1	33	014-0258-00	Male 90° Elbow	1
15	(N.L.A.)	Condensing Tank Lid (See Item #1)	1	34	014-0184-01	Male Elbow	1
16	014-0212-00	Connector	1	[*]	002-0593-00	Pressure Sensor Tube Kit (Includes #'s 19, 23, 26, 27, & 28)	
17	014-0252-00	Tube	1				
18	002-0375-00	Bellows Assembly	1				

Always Specify Model & Serial Number
N.L.A. Denotes "No Longer Available"

Plumbing & Sensor Components

SECTION VI PARTS LIST M11 / M11D

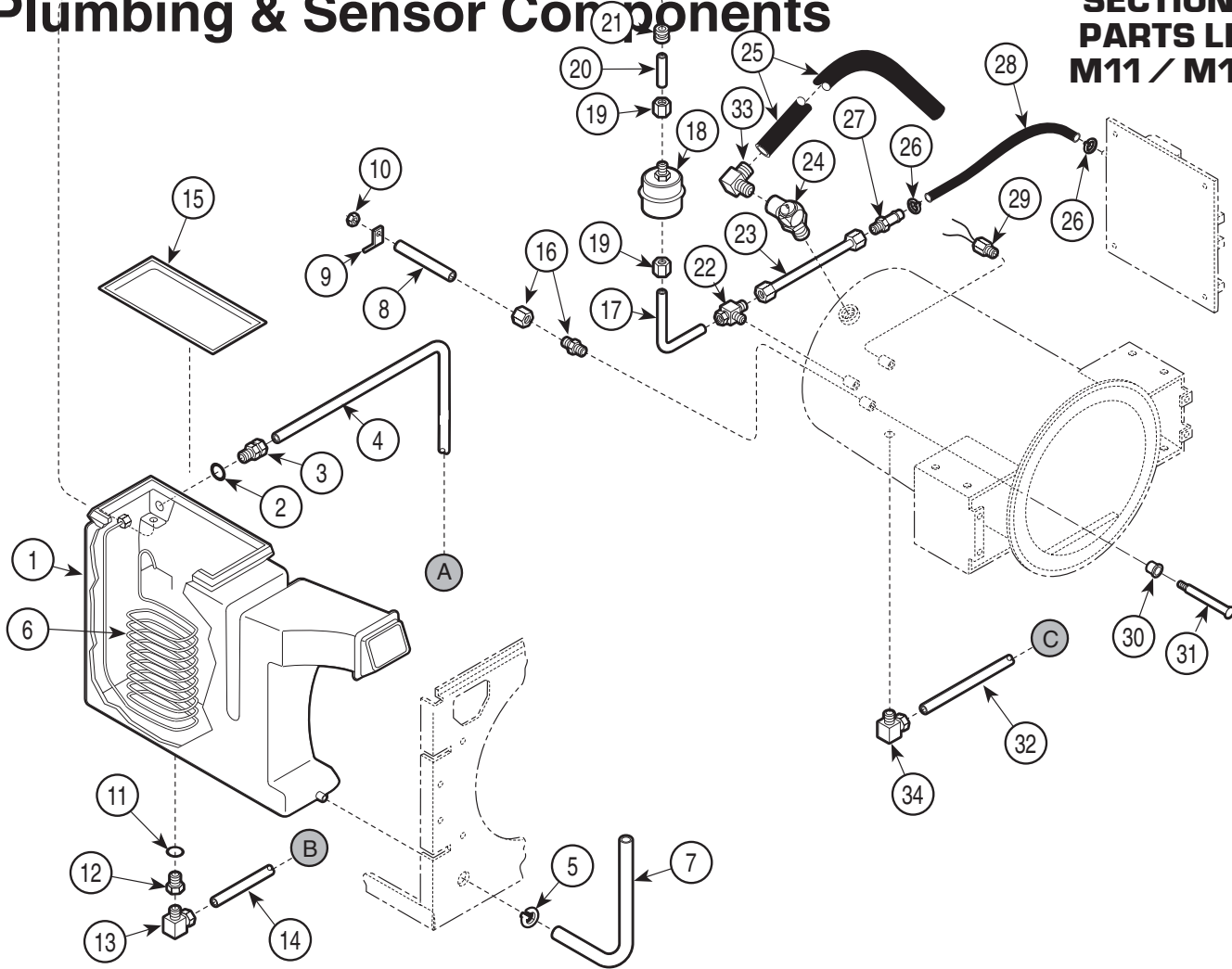

MA201915

Used on units with Serial Numbers:

ES4301 thru ES5751
GB1095 thru GB1129

ET5400 thru ET7341
GC1036 thru GC1093

FP1073 thru FP1075
GD1050 thru GD1102

FR1178 thru FR1246

Item	Part No.	Description	Qty.	Item	Part No.	Description	Qty.
1	053-0580-00	Condensing Tank (Includes Item 15)	1	19	014-0392-00	Compression Nut (Refer to Kit [*])	2
2	H98137	Gasket	1	20	014-0208-00	Tube	1
3	014-0216-00	Bulkhead Union	1	21	053-0394-01	Grommet	1
	014-0392-00	Compression Nut Only	AR	22	014-0202-00	Male Branch Tee	1
4	014-0251-00	Tube (M11)	1	23	014-0315-00	PCB Pres. Sensor Tube (Refer to Kit [*])	1
	014-0279-00	Tube (M11D)	1	24	002-0359-00	Pressure Relief Valve - 35 PSI (Apply Teflon Tape)	
5	016-0748-01	Nylon Hose Clamp	1			(Includes Elbow, Item 35)	1
6	052-0173-00	Condensing Coil	1	25	053-0613-02	Tube - Pressure Relief	1
7	053-0391-01	Hose	1	26	015-0013-05	Cable Tie (High Temp)	2
8	002-0358-00	Level Sensor Tube (Includes items 9, 10, 16, 30, and 31)	1	27	014-0217-00	Compression Connector (Refer to Kit [*])	1
9	015-0595-00	Terminal	1	28	053-0404-05	Tube-PCB Connector (Refer to Kit [*]) ...	1
10	041-0006-02	Locknut	1	29	002-0357-00	Temperature Probe Assembly (Apply Teflon Tape)	1
11	053-0393-00	O-ring	1	30	053-0407-00	Spacer	1
12	014-0209-00	Bulkhead Couple	1	31	030-0858-00	Level Sensor Assembly	1
13	014-0184-01	Male Elbow	1	32	014-0250-00	Tube	1
14	014-0255-00	Tube	1	33	014-0258-00	Male 90° Elbow	1
15	(N.L.A.)	Condensing Tank Lid (See Item #1)	1	34	014-0184-01	Male Elbow	1
16	014-0212-00	Connector	1	[*]	002-0593-00	Pressure Sensor Tube Kit (Includes #'s 19, 23, 26, 27, & 28)	
17	014-0252-00	Tube	1				
18	002-0375-00	Bellows Assembly	1				

Always Specify Model & Serial Number
N.L.A. Denotes "No Longer Available"

Plumbing & Sensor Components

SECTION VI PARTS LIST M11 / M11D

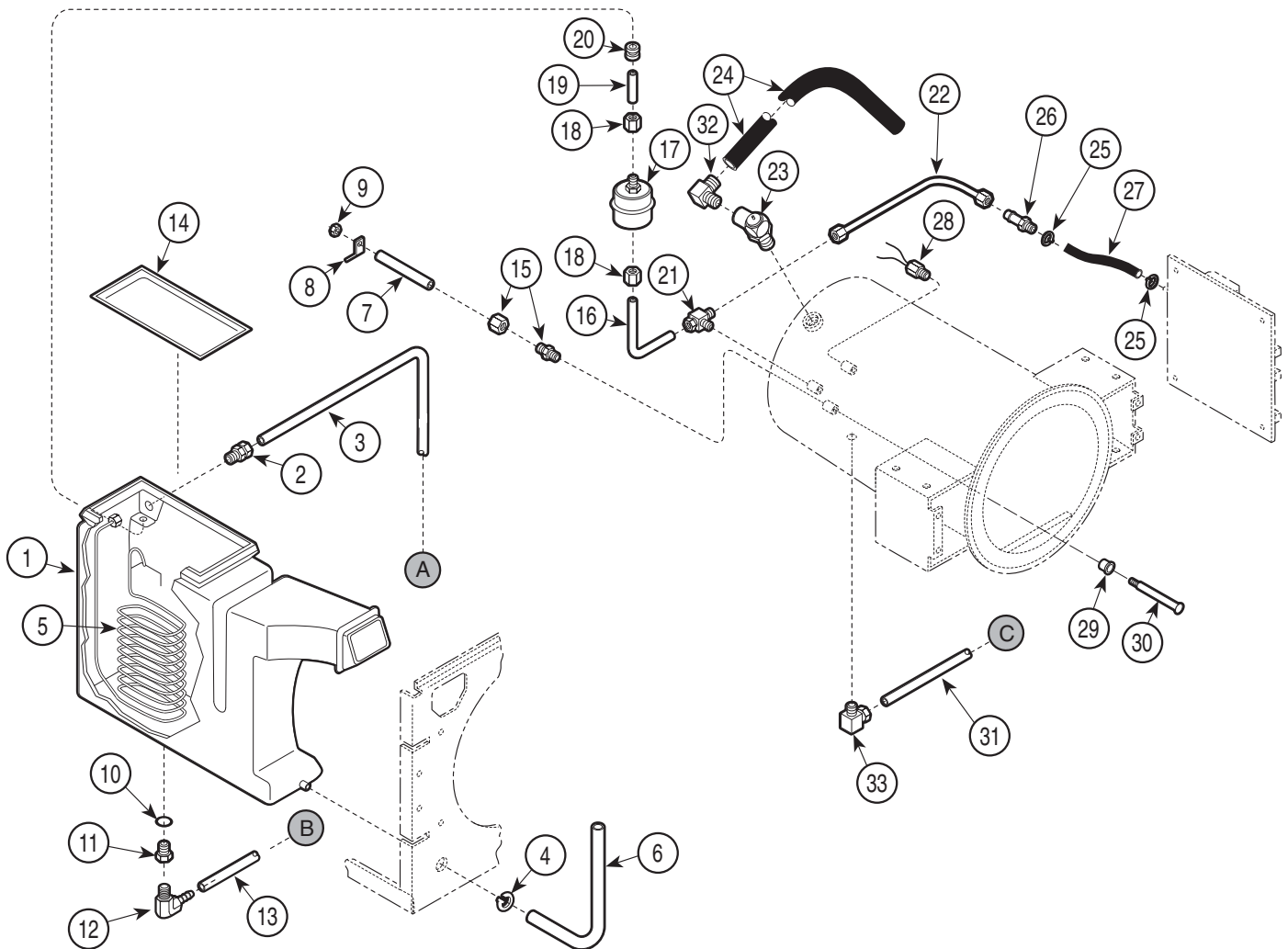

MA511004

Used on units with Serial Numbers:

ES5752 thru ES8308 ET7342 thru ET12157 FP1076 thru FP1148
FR1147 thru FR1412 GB1129 thru GB1130 NP1000 thru NP1004

Item	Part No.	Description	Qty.	Item	Part No.	Description	Qty.
1	053-0580-00	Condensing Tank (Includes Item 15)	1	19	014-0208-00	Tube	1
2	014-0216-00	Bulkhead Union	1	20	053-0394-01	Grommet	1
	014-0392-00	Compression Nut Only	AR	21	014-0202-00	Male Branch Tee	1
3	014-0251-00	Tube	1	22	014-0315-00	PCB Pres. Sensor Tube (Refer to Kit [*])	1
4	016-0748-01	Nylon Hose Clamp	1	23	002-0359-01	Pressure Relief Valve - 40 PSI (Apply Teflon Tape)	
5	052-0173-00	Condensing Coil	1			(Includes Elbow, Item 32)	1
6	053-0391-01	Hose	1	24	053-0613-02	Tube - Pressure Relief	1
7	002-0358-00	Level Sensor Tube (Includes items 8, 9, 15, 29, and 30)	1	25	015-0013-05	Cable Tie (High Temp)	2
8	015-0595-00	Terminal	1	26	014-0217-00	Compression Connector (Refer to Kit [*])	1
9	041-0006-02	Locknut	1	27	053-0404-05	Tube-PCB Connector (Refer to Kit [*]) ...	1
10	053-0393-00	O-ring	1	28	002-0357-00	Temperature Probe Assembly 29	
11	014-0209-00	Bulkhead Couple	1			(Apply Teflon Tape)	0
12	014-0348-00	Barb Fitting Elbow	1	29	053-0407-00	Spacer	1
13	053-1033-02	Norprene Tube	1	30	030-0858-00	Level Sensor Assembly	1
14	(N.L.A.)	Condensing Tank Lid (See Item #1)	1	31	014-0250-00	Tube	1
15	014-0212-00	Connector	1	32	014-0258-00	Male 90° Elbow	1
16	014-0252-00	Tube	1	33	014-0184-01	Male Elbow	1
17	002-0375-00	Bellows Assembly	1	[*]	002-0593-00	Pressure Sensor Tube Kit (Includes #'s 18, 22, 25, 26, & 27)	
18	014-0392-00	Compression Nut (Refer to Kit [*])	2				

Always Specify Model & Serial Number
N.L.A. Denotes "No Longer Available"

Plumbing & Sensor Components

SECTION VI PARTS LIST M11 / M11D

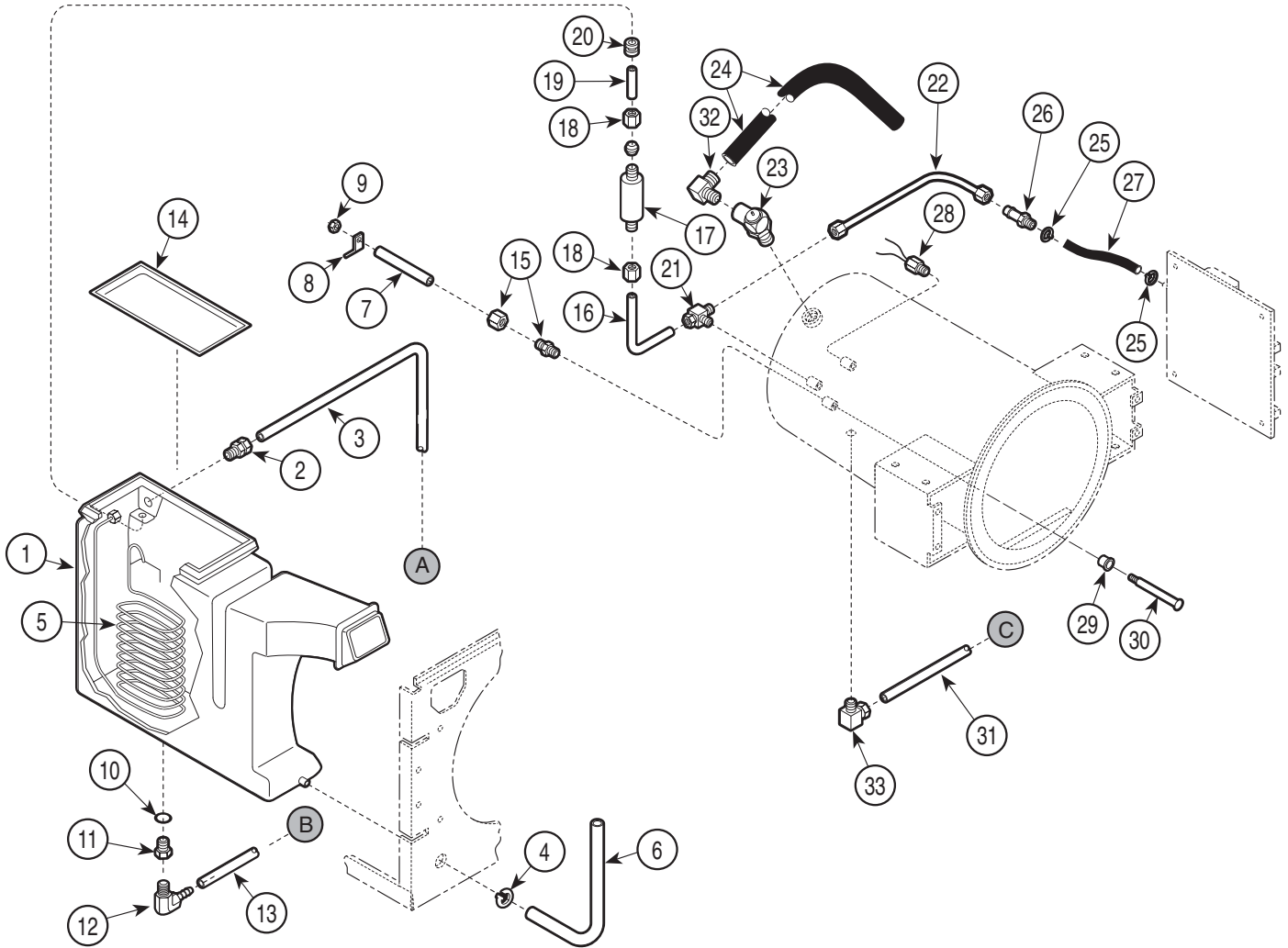

MA511005

Used on units with Serial Numbers:

ES8309, ET12158, FP1149, FR1413, GB1131, GC1094, GD1103, NP1005 - thru present

Item	Part No.	Description	Qty.	Item	Part No.	Description	Qty.
1	053-0580-00	Condensing Tank (Includes Item 15)	1	18	014-0392-00	Compression Nut (Refer to Kit [*])	2
2	014-0216-00	Bulkhead Union	1	19	014-0208-00	Tube	1
	014-0392-00	Compression Nut Only	AR	20	053-0394-02	Grommet	1
3	014-0251-00	Tube (M11)	1	21	014-0202-00	Male Branch Tee	1
	014-0279-00	Tube (M11D)	1	22	014-0315-00	PCB Pres. Sensor Tube (Refer to Kit [*])	1
4	016-0748-01	Nylon Hose Clamp	1	23	002-0359-01	Pressure Relief Valve - 40 PSI (Apply Teflon Tape)	
5	052-0173-00	Condensing Coil	1			(Includes Elbow, Item 32)	1
6	053-0391-01	Hose	1	24	053-0613-02	Tube - Pressure Relief	1
7	002-0358-00	Level Sensor Tube (Includes items 8,9,15,29,and 30)	1	25	015-0013-05	Cable Tie (High Temp)	2
8	015-0595-00	Terminal	1	26	014-0217-00	Compression Connector (Refer to Kit [*])	1
9	041-0006-02	Locknut	1	27	053-0404-05	Tube-PCB Connector (Refer to Kit [*]) ...	1
10	053-0393-00	O-ring	1	28	002-0357-00	Temperature Probe Assembly	
11	014-0209-00	Bulkhead Couple	1			(Apply Teflon Tape)	1
12	014-0348-00	Barb Fitting Elbow	1	29	053-0407-00	Spacer	1
13	053-1033-02	Norprene Tube	1	30	030-0858-00	Level Sensor Assembly	1
14	(N.L.A.)	Condensing Tank Lid (See Item #1)	1	31	014-0250-00	Tube	1
15	014-0212-00	Connector	1	32	014-0258-00	Male 90° Elbow	1
16	014-0252-00	Tube	1	33	014-0184-01	Male Elbow	1
17	002-0654-00	Steam Trap Assembly Kit (Includes Items 16, 18, 19 and 20)	1	[*]	002-0593-00	Pressure Sensor Tube Kit (Includes #'s 18, 22, 25, 26, & 27)	

Always Specify Model & Serial Number
N.L.A. Denotes "No Longer Available"

Pressure Vessel Components

SECTION VI PARTS LIST M11 / M11D

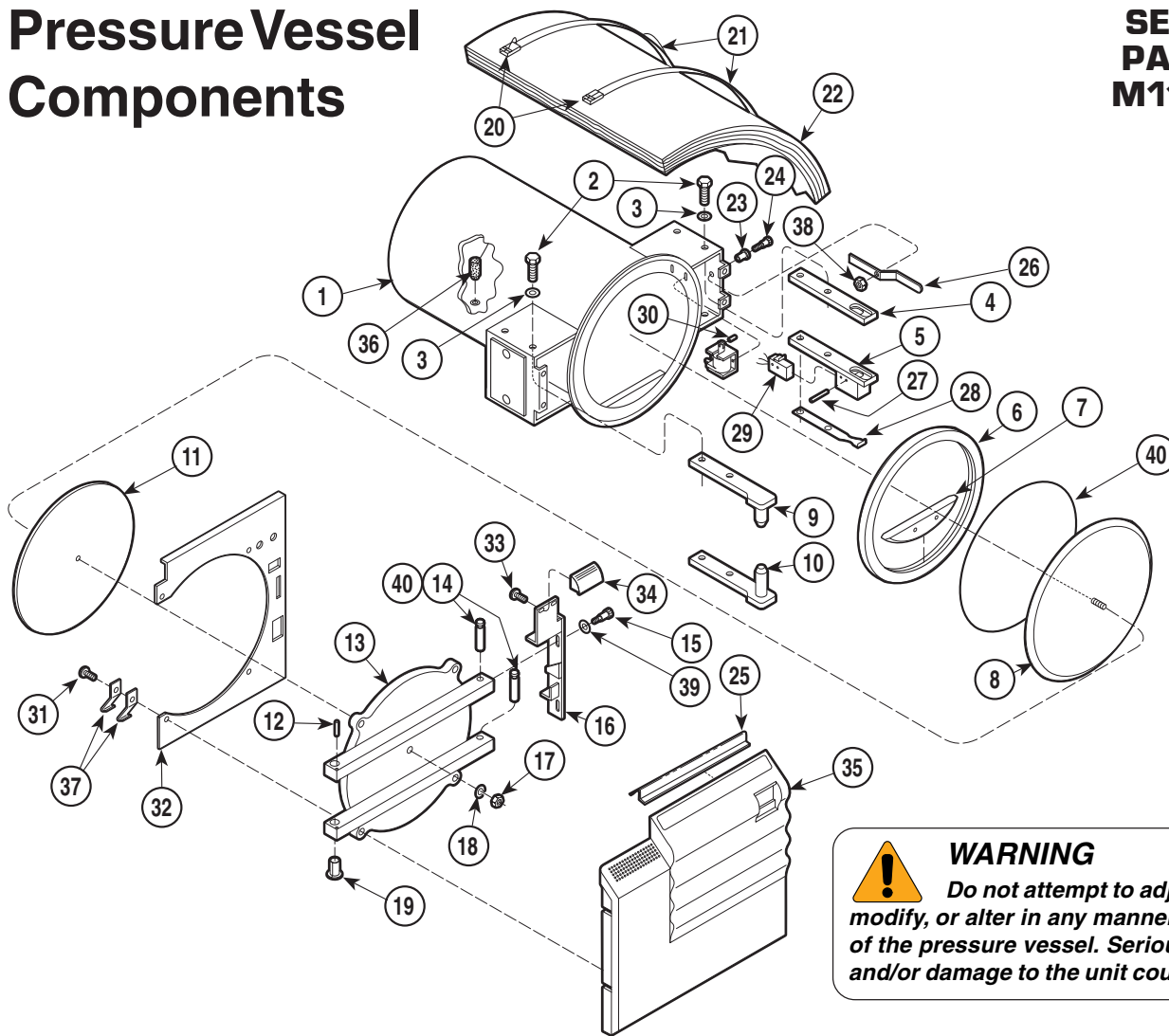

WARNING
Do not attempt to adjust, modify, or alter in any manner, any part of the pressure vessel. Serious injury and/or damage to the unit could result.

MA202016

Used on units with Serial Numbers:							
ES1000 thru ES4879 FR1000 thru FR1412			ET1000 thru ET6315 GB1000 thru GB1109		FP1000 thru FP1073		
Item	Part No.	Description	Qty.	Item	Part No.	Description	Qty.
1		Chamber	1	22	(N.L.A.)	Insulation Wrapper	1
2		Screw	8	23	016-0131-18	Flanged Bearing (Not used on M11D)	1
3		Washer	12	24	042-0106-00	Shoulder Screw (Not used on M11D)	1
4		Right Bracket	1			[Apply Valve Lubricant #064-0002-00]	1
5		Switch Bracket Weldment	1	25	053-0630-01	Steam Block	1
6	002-0504-00	Door Gasket Kit (Includes item 7)	1	26	050-5192-00	Latch Lever (Not used on M11D)	1
	• 053-0527-00	• Door Gasket	1	27	042-0001-23	Roll Pin	2
	• 053-0784-00	• Dam Gasket	1	28	050-5245-00	Spring Arm	1
7	002-0508-00	Dam Gasket Kit	1	29	002-0362-00	Door Switch (Includes Item 27)	1
	• 053-0784-00	• Dam Gasket	1	30	042-0001-09	Roll Pin (Not used on M11D)	1
8	030-0879-00	Gasket Housing Weldment	1	31	040-0008-87	Screw	4
9		Top Bracket	1	32	050-3969-00	Inside Door Cover	1
10		Bottom Bracket	1	33	040-0010-75	Screw	2
11	016-0395-02	Door Insulation Pad	1	34	053-0909-00	Door Handle	1
12	042-0104-00	Roll Pin	1	35	002-0506-00	Ritter M11 Door Panel (Incl. Decal)	1
13		Door	1		002-0506-01	Midmark M11 Door Panel (Incl. Decal)	1
14		Door Bolt	2		002-0506-04	EMS M11 Door Panel	1
15	042-0106-00	Shoulder Screw	2	36	002-0360-00	Filter	1
16	050-4183-00	Latch	1	37	050-2347-00	Door Spring	2
17	041-0000-00	Nut	1	38	041-0010-00	Nut	1
18	045-0000-00	Lockwasher	1	39	045-0000-04	Washer	2
19		Flange Bearing	2	40	064-0014-00	Grease	AR
20	H99387	Aluminum Seal	2	41	057-0790-00	Gasket Ring (Incl. in 002-0504-00 Kit)	1
21	H99388-44	Insulation Strap	2				

Always Specify Model & Serial Number
N.L.A. Denotes "No Longer Available"

Pressure Vessel Components

SECTION VI PARTS LIST M11 / M11D

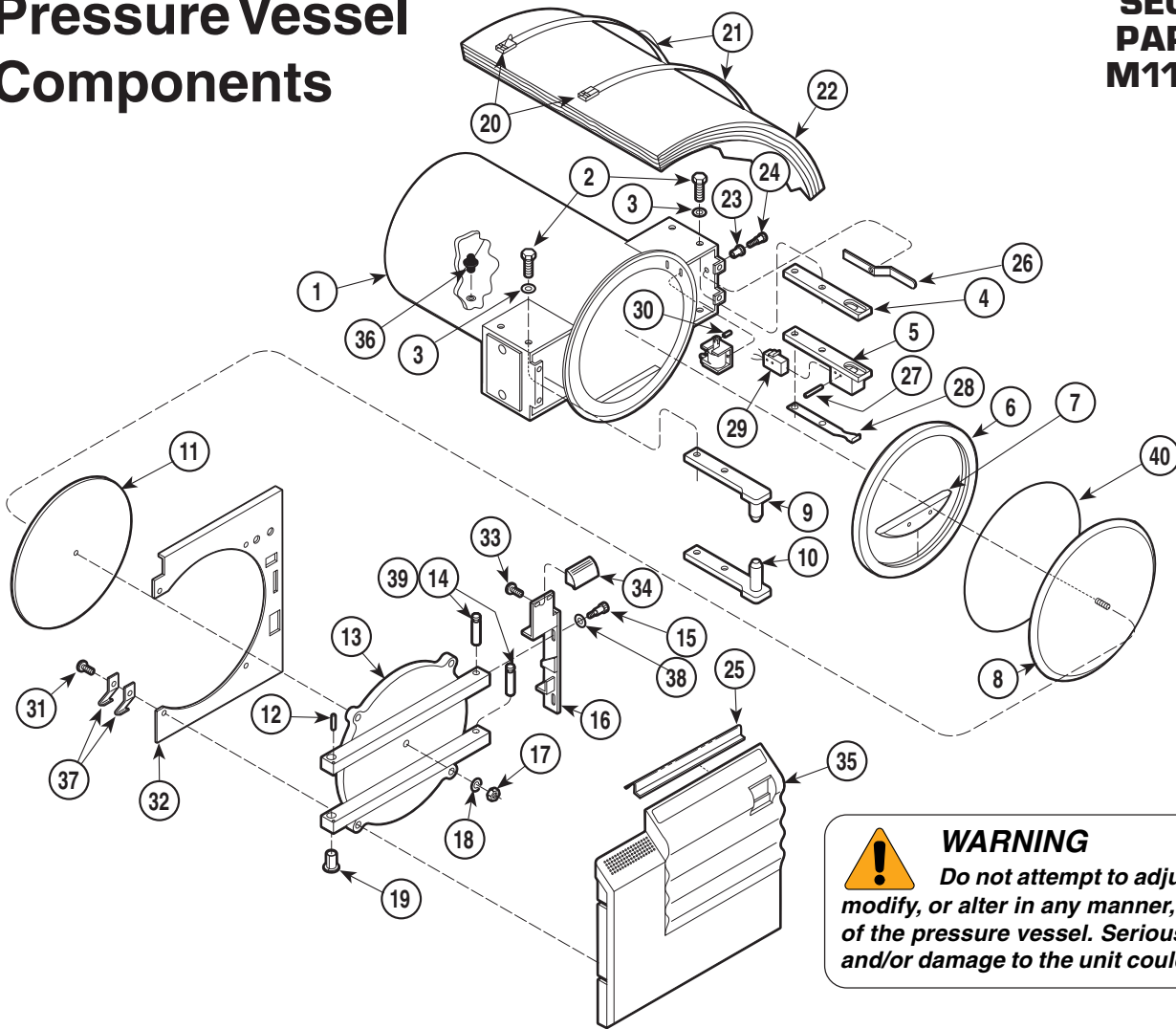

WARNING
Do not attempt to adjust, modify, or alter in any manner, any part of the pressure vessel. Serious injury and/or damage to the unit could result.

MA202014

Used on units with Serial Numbers:
ES4880, ET6316, FP1074, FR1204, GB1110, GC1000, GD1000, NP1000 - thru present

Item	Part No.	Description	Qty.	Item	Part No.	Description	Qty.
1		Chamber	1	23	016-0131-18	Flanged Bearing (Not used on M11D)	1
2		Screw	8	24	042-0106-00	Shoulder Screw (Not used on M11D) (apply lubricant #064-0002-00)]	1
3		Washer	12	25	053-0630-01	Steam Block	1
4		Right Bracket	1	26	050-5192-00	Latch Lever (Not used on M11D)	1
5		Switch Bracket Weldment	1	27	042-0001-23	Roll Pin	2
6	002-0504-00	Door Gasket Kit (Includes item 7)	1	28	050-5245-00	Spring Arm	1
	• 053-0527-00	• Door Gasket	1	29	002-0362-00	Door Switch (Includes Item 27)	1
	• 053-0904-00	• Dam Gasket	1	30	042-0001-09	Roll Pin (Not used on M11D)	1
7	002-0508-00	Dam Gasket Kit	1	31	040-0008-87	Screw	4
	• 053-0904-00	• Dam Gasket	1	32	050-3969-00	Inside Door Cover	1
8	030-0879-00	Gasket Housing Weldment	1	33	040-0010-75	Screw	2
9		Top Bracket	1	34	053-0909-00	Door Handle (M11)	1
10		Bottom Bracket	1		053-0909-01	Door Handle (M11D)	1
11	016-0395-02	Door Insulation Pad	1	35	002-0506-00	Ritter M11 Door Panel (w/ decal)	1
12	042-0104-00	Roll Pin	1		002-0506-01	Midmark M11 Door Panel (w/ decal)	1
13		Door	1		002-0506-02	M11D Door Panel	1
14		Door Bolt	2	36	002-0360-00	Filter	1
15	042-0106-00	Shoulder Screw	2	37	050-2347-00	Door Spring	2
16	050-4183-00	Latch	1	38	045-0000-04	Washer	2
17	041-0000-00	Nut	1	39	064-0014-00	Grease	AR
18	045-0000-00	Lockwasher	1	40	057-0790-00	Gasket Ring (Incl. in 002-0504-00 Kit)	1
19		Flange Bearing	2				
20	H99387	Aluminum Seal	2				
21	H99388-44	Insulation Strap	2				
22	(N.L.A.)	Insulation Wrapper	1				

Always Specify Model & Serial Number
N.L.A. Denotes "No Longer Available"

M11 Manifold Components

SECTION VI PARTS LIST M11 / M11D

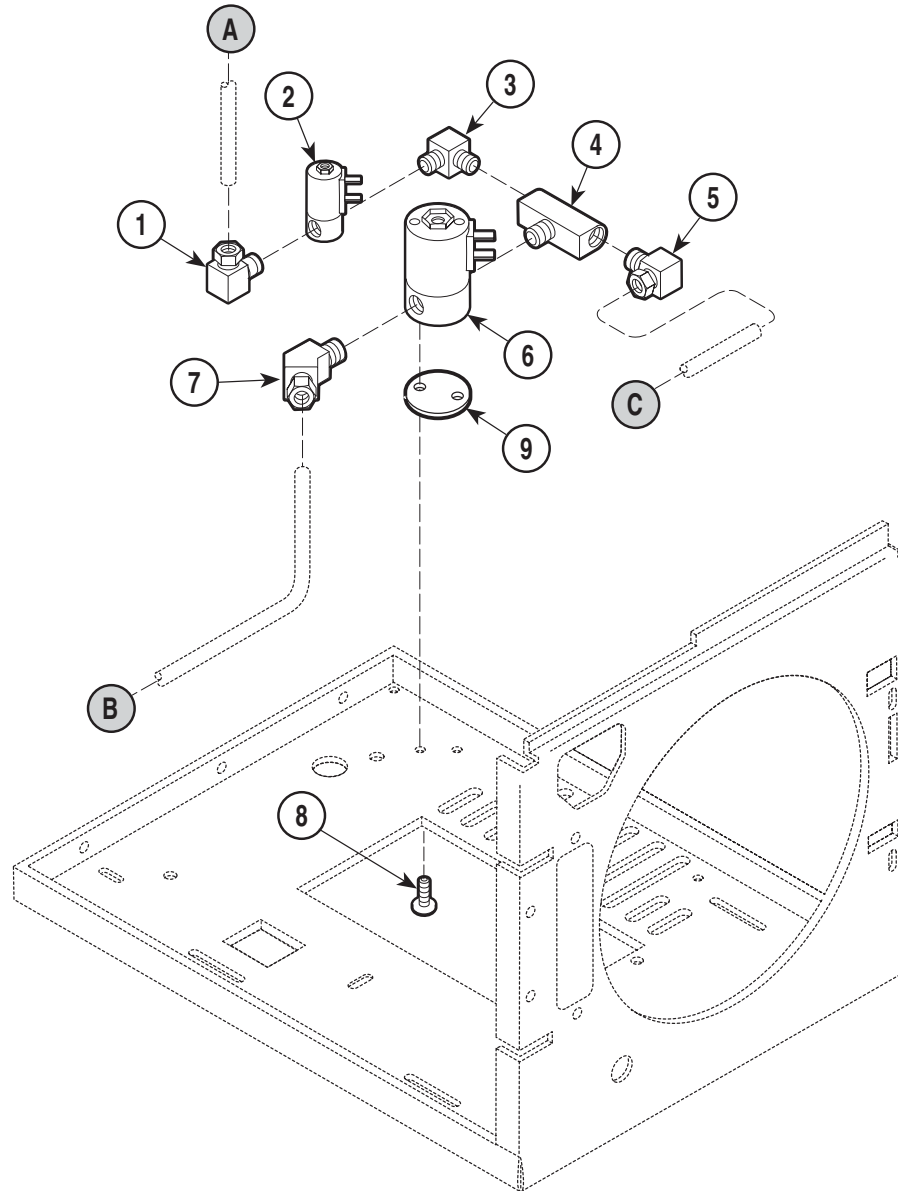

NOTE

When replacing components in the solenoid, examine the existing valve to determine if it was Full Wave Rectified (if so will be marked **FWR**).

MA202201

Used on Units with Serial Numbers ES1000 thru ES1346 ET1000 thru ET1094

Item	Part No.	Description	Qty.	Item	Part No.	Description	Qty.
	002-1428-00	Manifold Assembly (120V/60Hz) (includes items 1 thru 7)		5	•014-0184-01	Male 90° Elbow	1
	002-1428-01	Manifold Assembly (230V/50Hz) (includes items 1 thru 7)		6	•002-0365-00	Solenoid Valve (120V/60Hz) [Fill]	1
1	•014-0184-00	Male 90° Elbow	1		•002-0365-01	Solenoid Valve (230V/50Hz) [Fill]	1
2	•002-0366-00	Solenoid Valve (120V/60Hz) [Vent]	1		••014-0236-08	• Replacement Coil (120V/60Hz)	1
	•002-0366-01	Solenoid Valve (230V/50Hz) [Vent]	1		••014-0236-10	• Replacement Coil (120V/50-60 FWR) ..	1
	••014-0235-03	• Replacement Coil (120V/60Hz)	1		••014-0236-09	• Replmt. Plunger (120V/60Hz)	1
	••014-0235-04	• Replacement Plunger	1		••014-0236-11	• Replmt. Plunger (120V/50-60 FWR)	1
3	•014-0218-01	Male Elbow	1	7	•014-0201-00	Male 45° Elbow	1
4	•014-0234-00	Male Branch Tee	1	8	040-0010-74	Screw (Apply Loctite #042-0024-02)	2
				9	050-2657-00	Spacer	1

Always Specify Model & Serial Number

M11 Manifold Components

SECTION VI PARTS LIST M11 / M11D

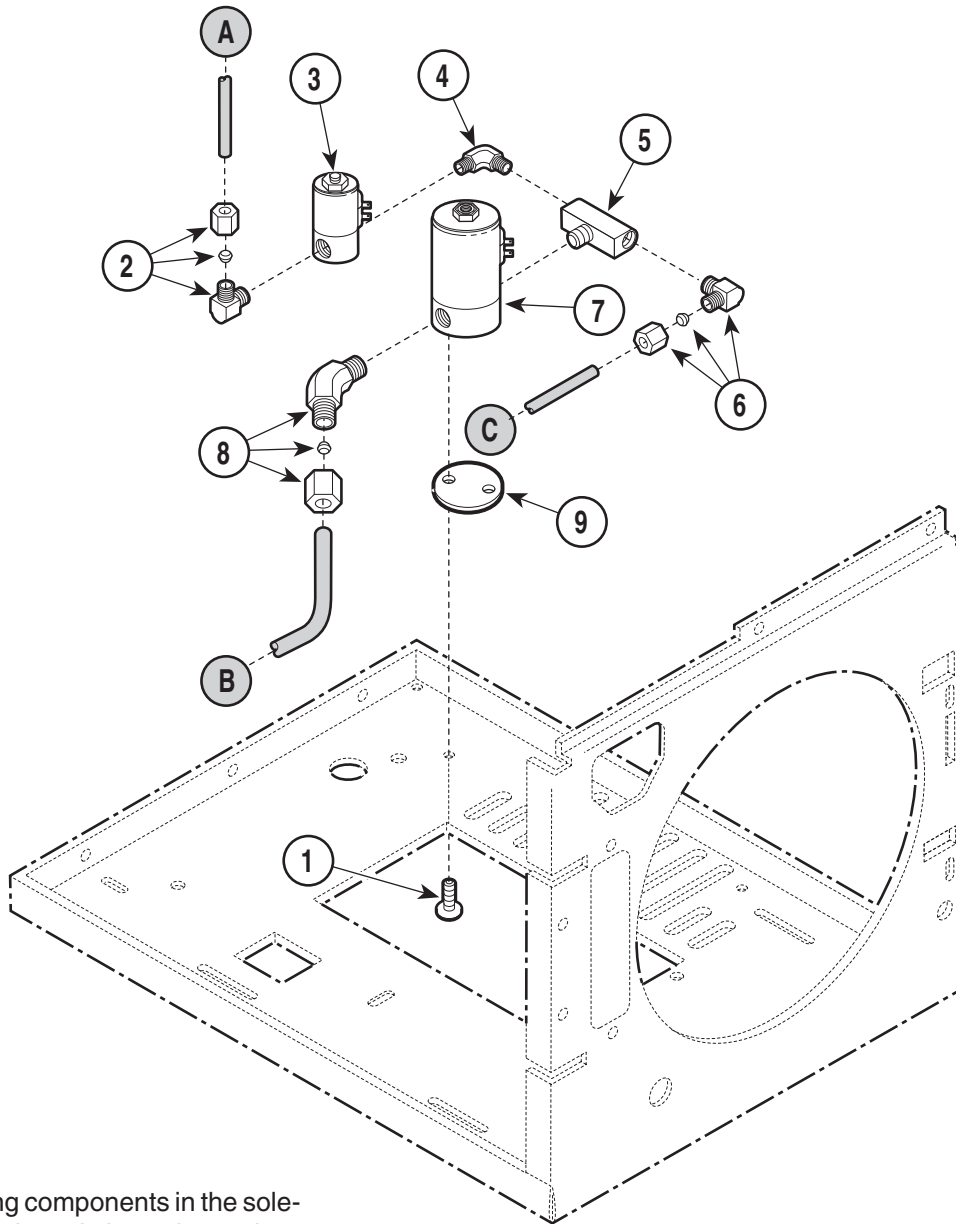

NOTE

When replacing components in the solenoid, examine the existing valve to determine if it was Full Wave Rectified (if so, will be marked **FWR**).

MA202206

Used on units with Serial Numbers:

ES1347 thru ES5751 ET1095 thru ET7341 FP1000 thru FP1075
FR1000 thru FR1246 GB1000 thru GB1129

Item	Part No.	Description	Qty.	Item	Part No.	Description	Qty.
	002-1428-00	Manifold Assembly (120V/60Hz) (includes items 2 thru 8)		5	• 014-0234-00	Male Branch Tee	1
	002-1428-01	Manifold Assembly (230V/50Hz) (includes items 2 thru 8)		6	• 014-0184-01	Male 90° Elbow	1
1	040-0010-74	Screw (Apply Loctite #042-0024-02)	2	7	• 002-0365-00	Solenoid Valve (120V/60Hz) [Fill]	1
2	• 014-0184-00	Male 90° Elbow	1		• 002-0365-01	Solenoid Valve (230V/50Hz) [Fill]	1
3	• 002-0366-00	Solenoid Valve (120V/60Hz) [Vent]	1		• 014-0236-08	• Replacement Coil (120V/60Hz)	1
	• 002-0366-01	Solenoid Valve (230V/50Hz) [Vent]	1		• 014-0236-10	• Replacement Coil (120V/50-60 FWR) ..	1
	• • 014-0235-03	• Replacement Coil (120V/60Hz)	1		• 014-0236-09	• Replmt. Plunger (120V/60Hz)	1
	• • 014-0235-04	• Replacement Plunger	1		• 014-0236-11	• Replmt. Plunger (120V/50-60 FWR)	1
4	• 014-0218-01	Male Elbow	1		• • 002-0694-00	• Replmt. Plunger & Coil (FWR)	1
				8	• 014-0201-00	Male 45° Elbow	1
				9	050-2657-00	Spacer	1

Always Specify Model & Serial Number

M11 Manifold Components

SECTION VI PARTS LIST M11 / M11D

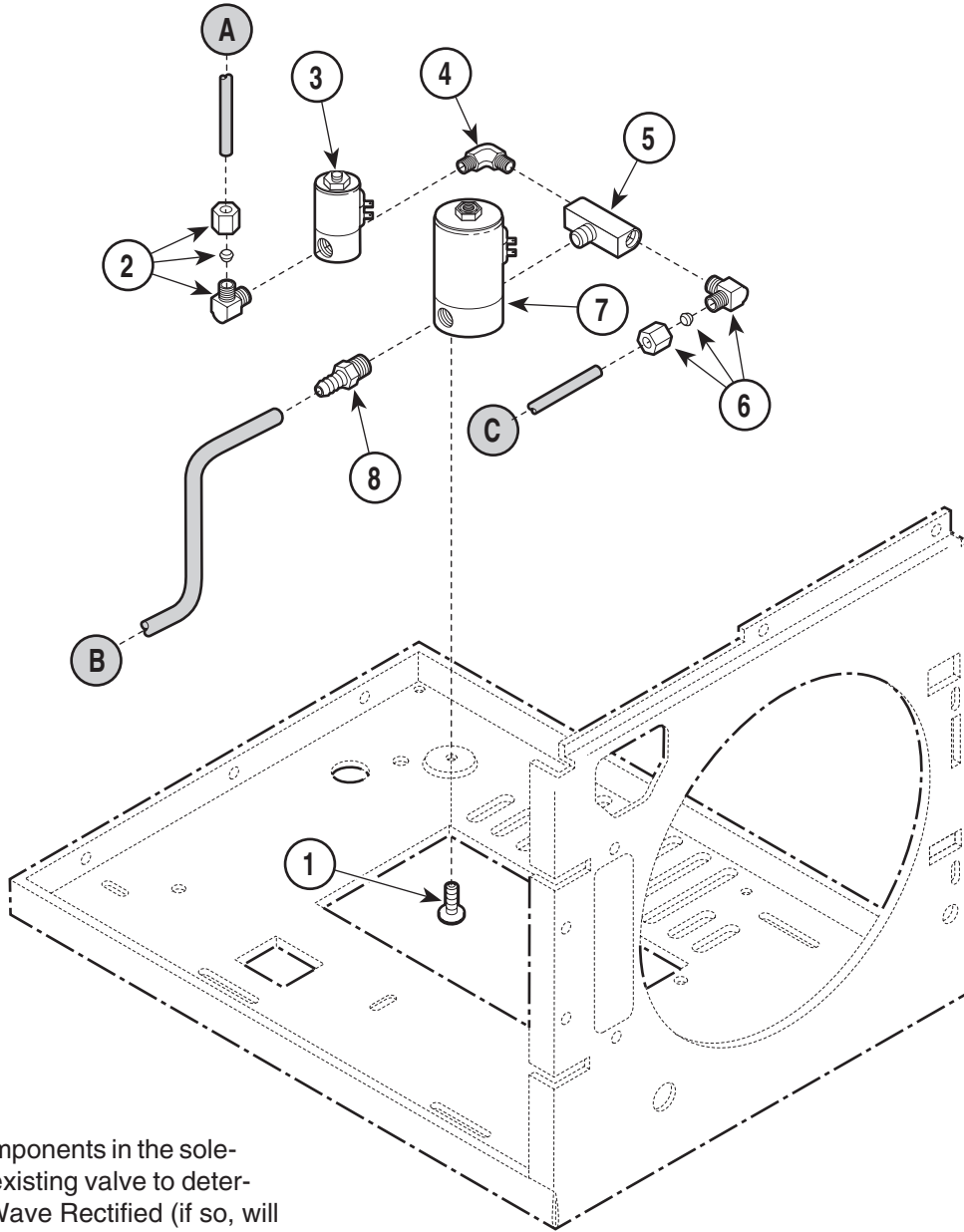

NOTE

When replacing components in the solenoid, examine the existing valve to determine if it was Full Wave Rectified (if so, will be marked **FWR**).

MA511400

Used on units with Serial Numbers: ES5752, ET7342, FP1076, FR1247, GB1130, NP1000 - thru present							
Item	Part No.	Description	Qty.	Item	Part No.	Description	Qty.
	029-1271-00	Manifold Assembly (120V/60Hz) (includes items 2 thru 8)		5	• 014-0234-00	Male Branch Tee	1
	029-1271-01	Manifold Assembly (230V/50Hz) (includes items 2 thru 8)		6	• 014-0184-01	Male 90° Elbow	1
1	040-0010-74	Screw (Apply Loctite #042-0024-02)	2	7	• 002-0365-00	Solenoid Valve (120V/60Hz) [Fill]	1
2	• 014-0184-00	Male 90° Elbow	1		• 002-0365-01	Solenoid Valve (230V/50Hz) [Fill]	1
3	• 002-0366-00	Solenoid Valve (120V/60Hz) [Vent]	1		• 014-0236-08	• Replacement Coil (120V/60Hz)	1
	• 002-0366-01	Solenoid Valve (230V/50Hz) [Vent]	1		• 014-0236-10	• Replacement Coil (120V/50-60 FWR) ..	1
	• 014-0235-03	• Replacement Coil (120V/60Hz)	1		• 014-0236-09	• Replmt. Plunger (120V/60Hz)	1
	• 014-0235-04	• Replacement Plunger	1		• 014-0236-11	• Replmt. Plunger (120V/50-60 FWR)	1
4	• 014-0218-01	Male Elbow	1		• 002-0694-00	• Replmt. Plunger & Coil (FWR)	1
				8	• 014-0347-00	Barb Fitting Elbow	1

Always Specify Model & Serial Number

M11D Manifold Components

SECTION VI PARTS LIST M11 / M11D

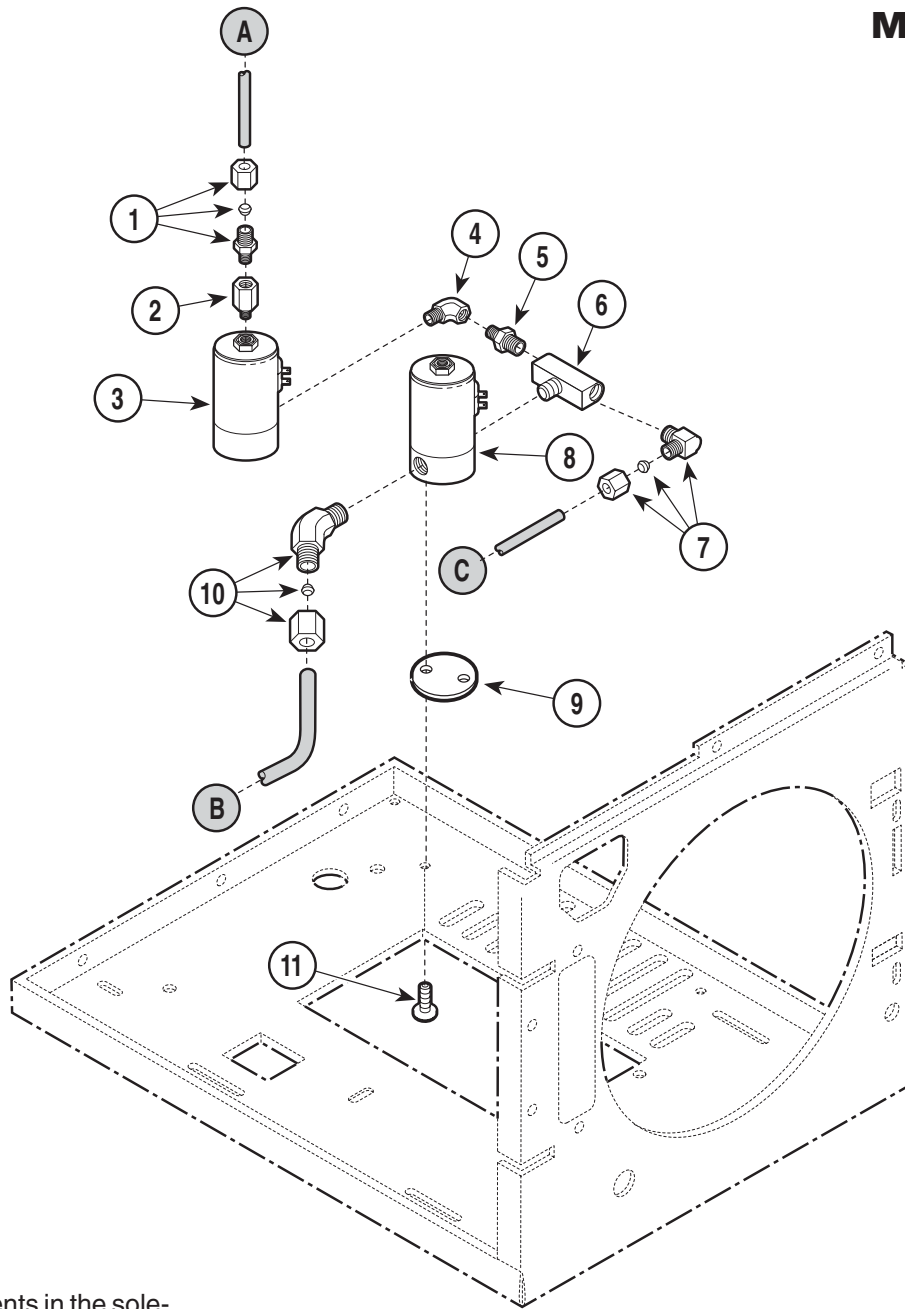

NOTE

When replacing components in the solenoid, examine the existing valve to determine if it was Full Wave Rectified (if so, will be marked **FWR**).

MA202207

Used on Units with Serial Numbers GC1000 thru GC1093 GD1000 thru GD1102

Item	Part No.	Description	Qty.	Item	Part No.	Description	Qty.
1	014-0183-01	Male Connector	1	8	002-0365-00	Solenoid Valve{120V/60Hz}	1
2		Reducer Fitting	1		• 014-0236-08	• Replacement Coil (120V/60Hz)	1
3	002-0519-00	Solenoid Valve {120V/60Hz} (Includes Item 2	1		• 014-0236-10	• Replacement Coil (120V/50-60 FWR) ..	1
	• 014-0275-02	• Replacement Coil & Plunger	1		• 014-0236-09	• Replmt. Plunger (120V/60Hz)	1
4	014-0194-00	Street Elbow	1		• 014-0236-11	• Replmt. Plunger (120V/50-60 FWR)	1
5	014-0276-00	Reducer Nipple	1		• 002-0694-00	• Replmt. Plunger & Coil (FWR)	1
6	014-0234-00	Male Branch Tee	1	9	050-2657-00	Spacer	1
7	014-0184-01	Male 90° Elbow	1	10	014-0201-00	Male 45° Elbow	1
				11	040-0010-74	Screw (Apply Loctite #042-0024-02)	2

Always Specify Model & Serial Number

M11D Manifold Components

SECTION VI PARTS LIST M11 / M11D

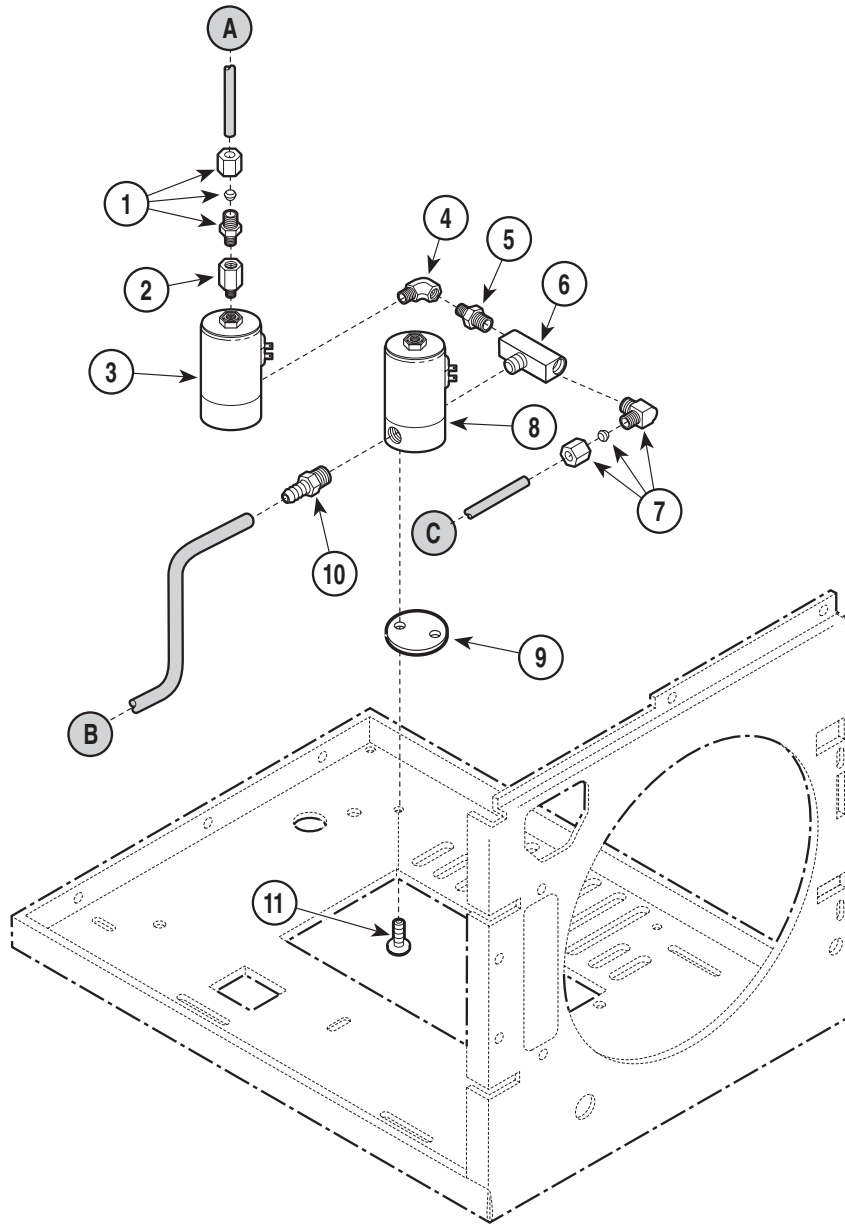

NOTE

When replacing components in the solenoid, examine the existing valve to determine if it was Full Wave Rectified (if so, will be marked **FWR**).

MA510900

Used on Units with Serial Numbers GC1094 & GD1103 - thru present

Item	Part No.	Description	Qty.	Item	Part No.	Description	Qty.
1	014-0183-01	Male Connector	1	8	002-0365-00	Solenoid Valve{120V/60Hz}[Fill]	1
2		Reducer Fitting	1		• 014-0236-08	• Replacement Coil (120V/60Hz)	1
3	002-0519-00	Solenoid Valve {120V/60Hz}[Vent] (Includes Item 2	1		• 014-0236-10	• Replacement Coil (120V/50-60 FWR) ..	1
	• 014-0275-02	• Replacement Coil & Plunger	1		• 014-0236-09	• Replmt. Plunger (120V/60Hz)	1
4	014-0194-00	Street Elbow	1		• 014-0236-11	• Replmt. Plunger (120V/50-60 FWR)	1
5	014-0276-00	Reducer Nipple	1		• 014-0236-04	• Replacement Plunger	1
6	014-0234-00	Male Branch Tee	1		• 002-0694-00	• Replmt. Plunger & Coil (FWR)	1
7	014-0184-01	Male 90° Elbow	1	9	050-2657-00	Spacer (Used with Flat Surface Base) ...	1
				10	014-0347-00	Barb Fitting	1
				11	040-0010-74	Screw (Apply Loctite #042-0024-02)	2

Always Specify Model & Serial Number

Electrical Components

SECTION VI PARTS LIST M11 / M11D

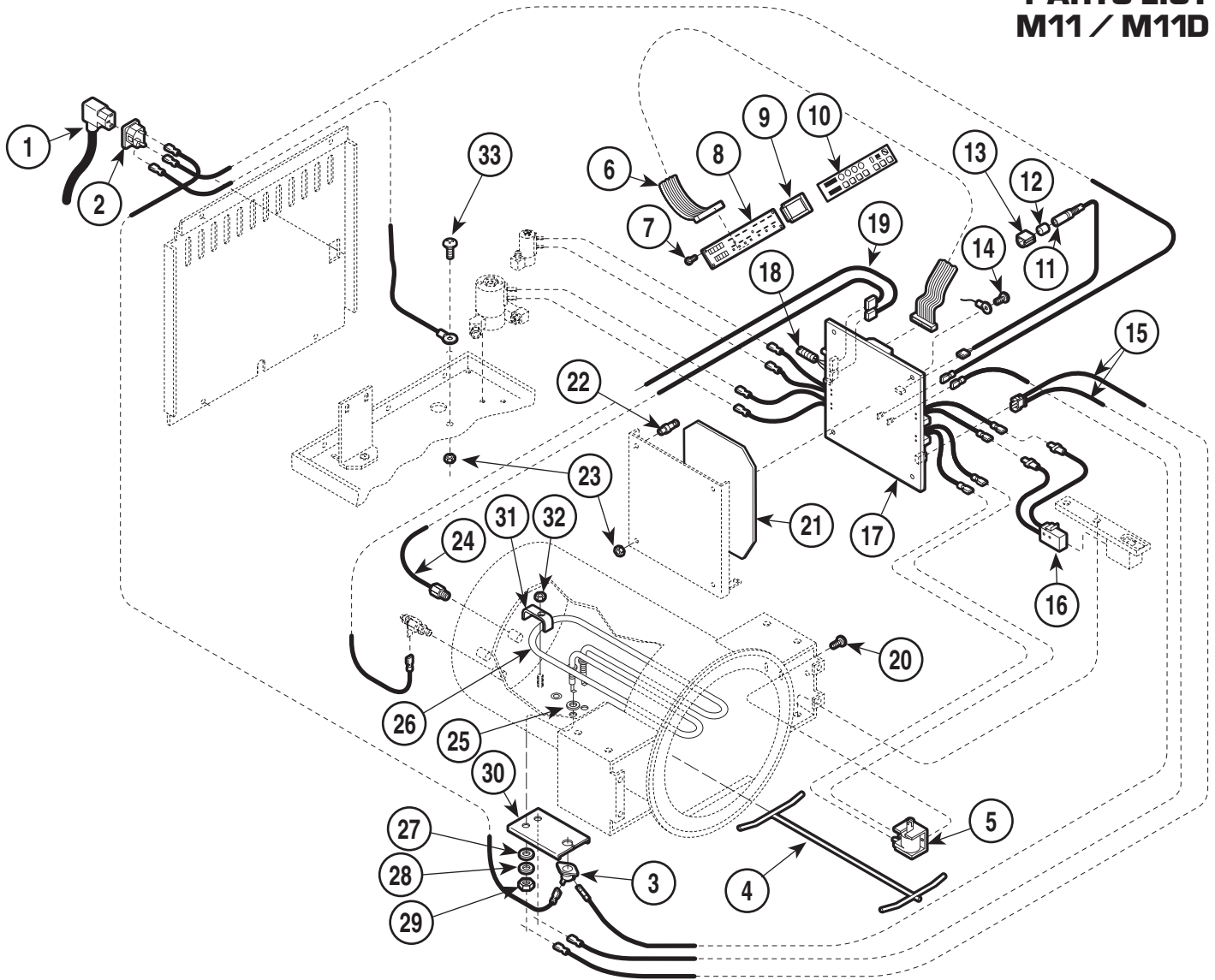

MA202305

Used on Units with Serial Numbers ES1000 thru ES1346 ET1000 thru ET1094

Item	Part No.	Description	Qty.	Item	Part No.	Description	Qty.
1		Cordset (Refer to W/D in Section 5) ...	Ref	18	015-0257-02	Flex Guard Tubing	1
2	015-0639-00	AC Connector Receptacle	1	19	015-0654-00	Chamber Level Sensor Harness	1
3	002-0370-00	Thermostat	1	20	040-0010-74	Screw	2
4	030-0916-00	Spacer Assembly	1	21	053-0792-00	Insulator	1
5	002-0363-03	Solenoid-{120V}	1	22	053-0295-01	Standoff	3
6	015-0646-00	Ribbon Connector	1	23	041-0010-04	Locknut	2
7	040-0006-04	Screw	6	24		Temperature Probe Assembly (Refer to "Plumbing & Sensor Components Elsewhere)	Ref
8	002-0369-00	Display PC Board	1	25	H98137	Gasket	2
9	053-0454-00	Display Gasket	1	26	002-0505-00	Heat Element-{120V} (Incl. Gaskets)	1
10	061-0272-01	Display Overlay	1	27	H97971	Washer	2
11	015-0978-00	Harness - PCB/Printer	1	28	045-0001-56	Lockwasher	2
12	053-0440-00	Cap Plug	1	29		Nut (Included with Item 26)	2
13	053-0389-00	Printer Harness Clip	1	30	H225617	Bracket	1
14	040-0010-46	Screw	1	31	050-3340-00	Heater Bracket	1
15	015-0657-00	PCB/Heater Harness	1	32	041-0250-18	Nut	1
16		Switch Assembly (Refer to "Pressure Vessel Components" Elsewhere)	Ref	33	040-0010-75	Screw	1
17		Control PC Board (Refer to "Control PC Board" Elsewhere)	Ref				

Always Specify Model & Serial Number

Electrical Components

SECTION VI PARTS LIST M11 / M11D

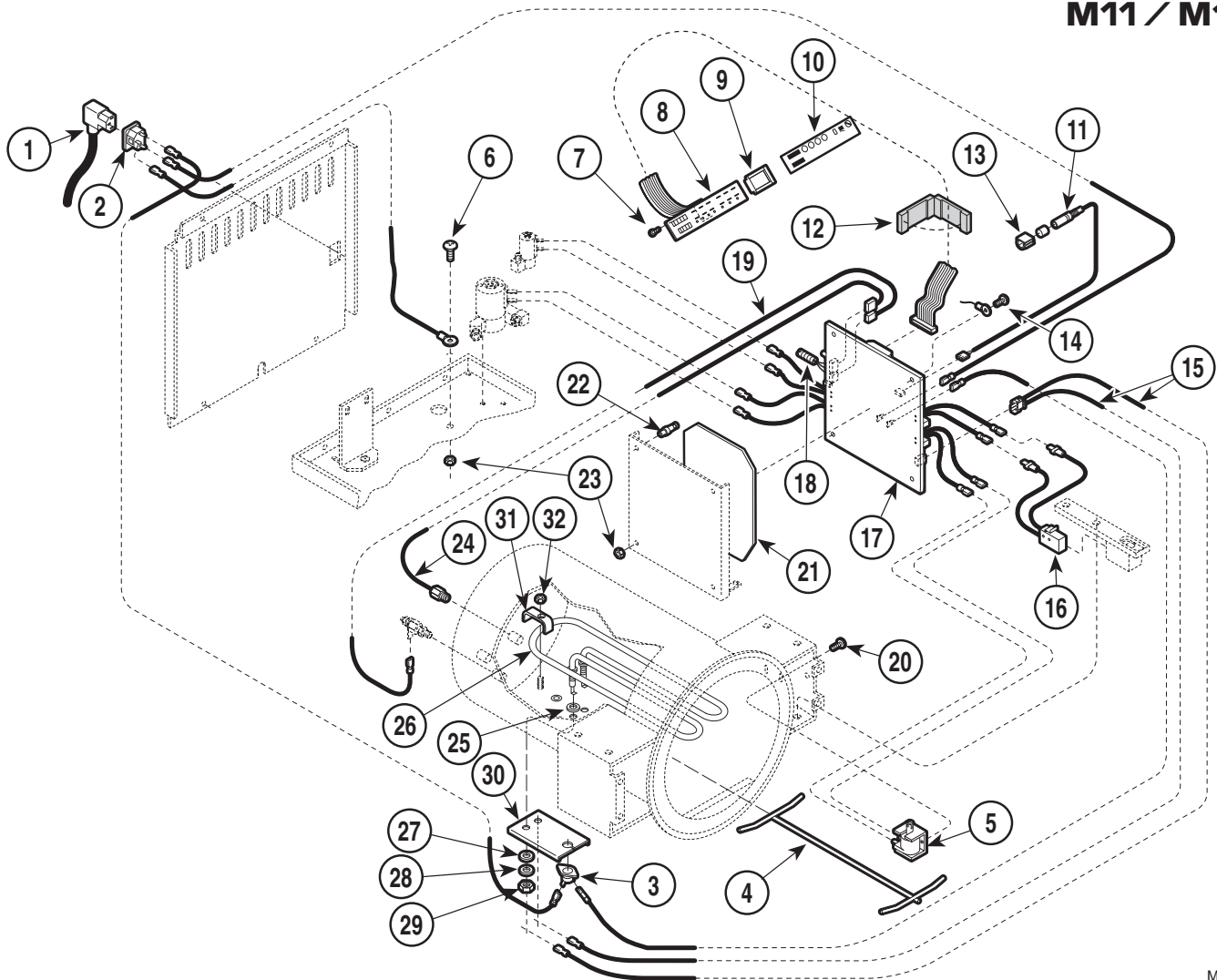

MA202308

Used on units with Serial Numbers:							
ES1347 thru ES3020		ET1095 thru ET3317		GC1000 thru GC1018		GD1000 thru GD1015	
Item	Part No.	Description	Qty.	Item	Part No.	Description	Qty.
1		Cordset (Refer to W/D in Section 5) ...	Ref			Vessel Components" Elsewhere)	Ref
2	015-0639-00	AC Connector Receptacle	1	17		Control PC Board (Refer to "Control PC Board" Elsewhere)	Ref
3	002-0370-00	Thermostat	1	18	015-0257-02	Flex Guard Tubing	1
4	057-0426-00	Spacer Assembly	1	19	015-0654-00	Chamber Level Sensor Harness	1
5	002-0363-03	Solenoid-{120V}	1	20	040-0010-74	Screw	2
	002-0363-04	Solenoid-{230V}	1	21	053-0792-00	Insulator	1
6	040-0010-75	Screw	1	22	053-0295-01	Standoff	3
7	040-0006-04	Screw (Apply Loctite #042-0024-00)	6	23	041-0010-04	Locknut	2
8	002-0369-02	Display PC Board	1	24		Temperature Probe Assembly (Refer to "Plumbing & Sensor Components Elsewhere)	Ref
9	053-0454-00	Display Gasket	1	25	H98137	Gasket	2
10	061-0272-01	M11 Display Overlay	1	26	002-0505-00	Heat Element-{120V} (Incl. Gaskets)	1
	061-0531-00	M11D Display Overlay	1		002-0505-01	Heat Element-{230V} (Incl. Gaskets)	1
	061-0272-00	M11 Display Overlay (metric)	1	27	H97971	Washer	2
	061-0272-02	M11 Display Overlay (French)	1	28	045-0001-56	Lockwasher	2
11		Harness - PCB/Printer (Refer to "Printer Components" Elsewhere)	1	29		Nut (Included with Item 26)	2
12	015-1096-00	Flat Cable EMI Suppression Core (Used On Certain Export Units)	1	30	050-3503-00	Thermostat Bracket	1
13	053-0389-01	Printer Harness Clip	1	31	050-3340-00	Heater Bracket	1
14	040-0010-46	Screw	1	32	041-0250-18	Nut	1
15	015-0657-00	PCB/Heater Harness	1				
16		Switch Assembly (Refer to "Pressure					

Always Specify Model & Serial Number

Electrical Components

SECTION VI PARTS LIST M11 / M11D

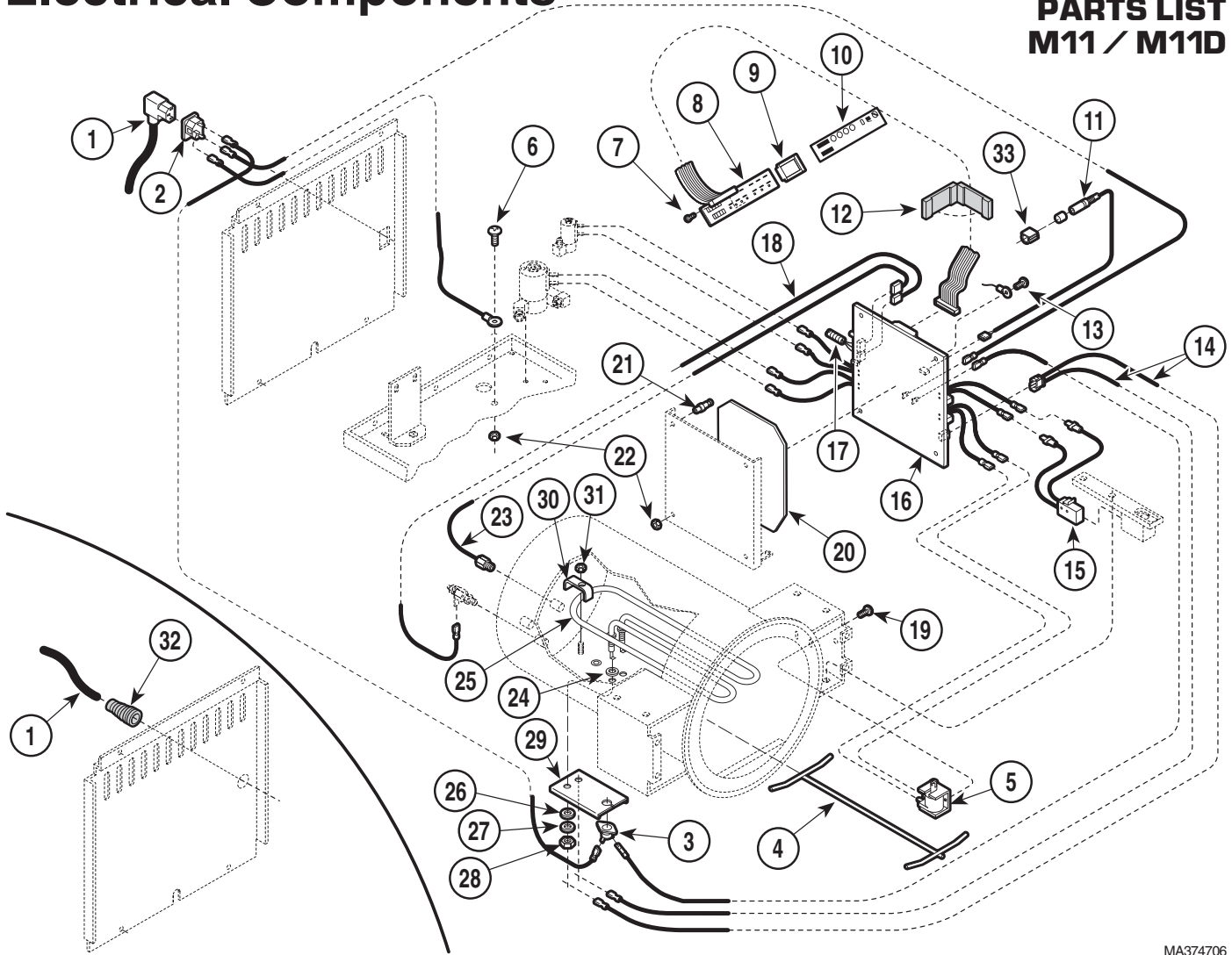

MA374706

Used on units with Serial Numbers:

ES3021 thru ES7392
FR1000 thru FR1356

ET3318 thru ET10311

FP1000 thru FP1143
GB1000 thru GB1128

Item	Part No.	Description	Qty.	Item	Part No.	Description	Qty.
1		Cordset (Refer to W/D in Section 5) ...	Ref	17	015-0257-02	PC Board" Elsewhere)	Ref
2	015-0639-00	AC Receptacle (230V. Units Only)	1	18	015-0654-00	Flex Guard Tubing	1
3	002-0370-00	Thermostat	1	19	040-0010-74	Chamber Level Sensor Harness	1
4	057-0426-00	Spacer Assembly	1	20	053-0792-00	Screw	2
5	002-0363-03	Solenoid-{120V}	1	21	053-0295-01	Insulator	1
	002-0363-04	Solenoid-{230V}	1	22	041-0010-04	Standoff	3
6	040-0010-75	Screw	1	23		Locknut	2
7	040-0006-04	Screw (Apply Loctite #042-0024-00)	6			Temperature Probe Assembly (Refer to "Plumbing & Sensor Components Elsewhere)	Ref
8	002-0369-02	Display PC Board	1	24	H98137	Gasket	2
9	053-0454-00	Display Gasket	1	25	002-0505-00	Heat Element-{120V} (Incl. Gaskets)	1
10	061-0272-01	M11 Display Overlay	1		002-0505-01	Heat Element-{230V} (Incl. Gaskets)	1
	061-0272-00	M11 Display Overlay (metric)	1	26	H97971	Washer	2
	061-0272-02	M11 Display Overlay (French)	1	27	045-0001-56	Lockwasher	2
11		Harness - PCB/Printer (Refer to "Printer Components" Elsewhere)	1	28		Nut (Included with Item 26)	2
12	015-1096-00	Flat Cable EMI Suppression Core (Used On Certain Export Units)	1	29	050-3503-00	Thermostat Bracket	1
13	040-0010-46	Screw	1	30	050-3340-00	Heater Bracket	1
14	015-0657-00	PCB/Heater Harness	1	31	041-0250-18	Nut	1
15		Switch Assembly (Refer to "Pressure Vessel Components" Elsewhere)	Ref	32	015-1137-00	Strain Relief Bushing (120V. Units Only) ..	1
16		Control PC Board (Refer to "Control Components" Elsewhere)	Ref	33	053-0389-01	Printer Harness Clip	1

Always Specify Model & Serial Number

Electrical Components

SECTION VI PARTS LIST M11 / M11D

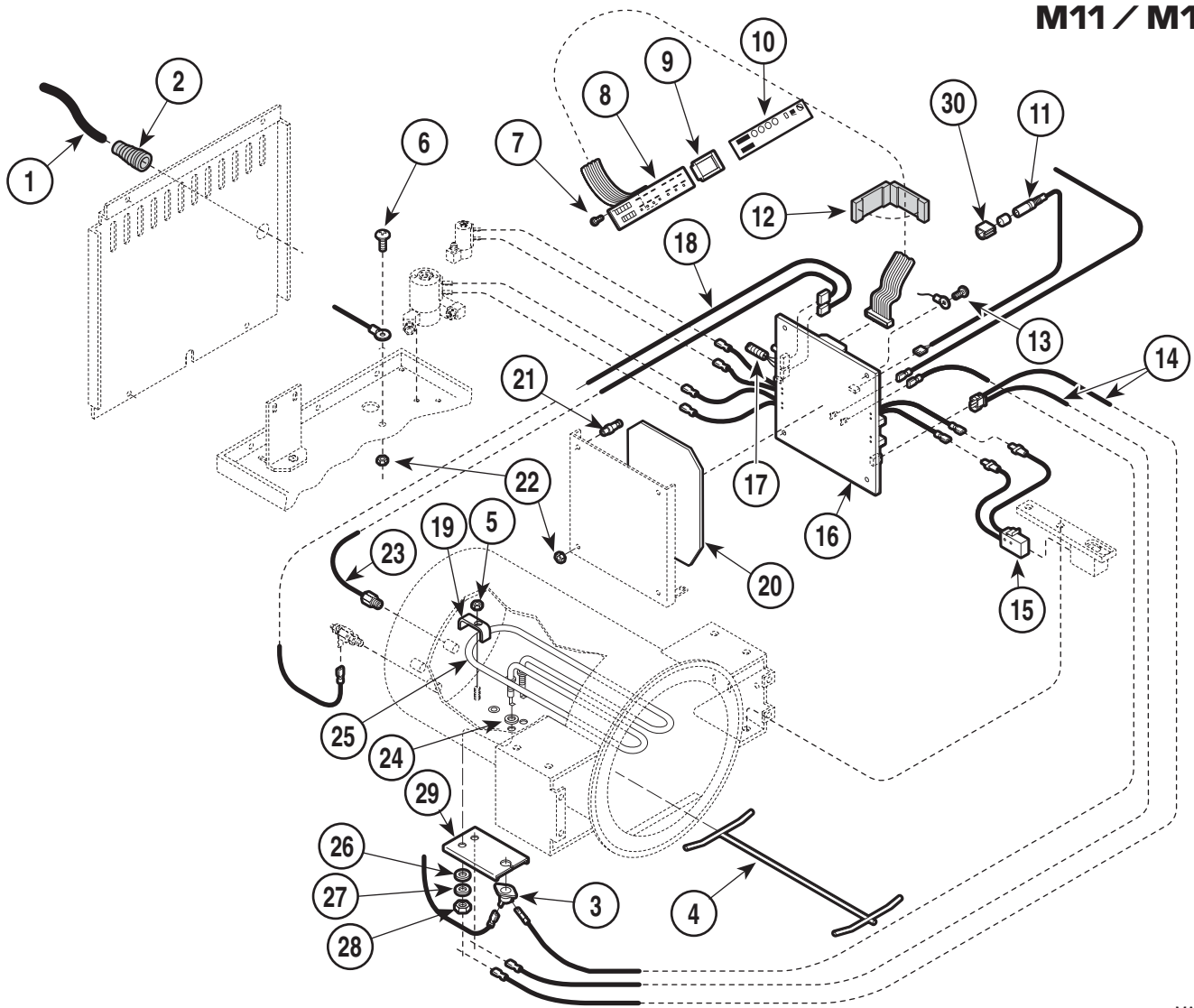

MA374707

Used on Units with Serial Numbers: GC1019 thru GC1155 GD1016 thru GD1192

Item	Part No.	Description	Qty.	Item	Part No.	Description	Qty.
1		Cordset (Refer to "Wiring Diagrams" in Section 5)	Ref	16		Control PC Board (Refer to "Control PC Board" Elsewhere)	Ref
2	015-1137-00	Strain Relief Bushing	1	17	015-1395-00	Flex Guard Tubing	1
3	002-0370-00	Thermostat	1	18	015-0654-00	Chamber Level Sensor Harness	1
4	057-0426-00	Spacer Assembly	1	19	050-3340-00	Heater Bracket	1
5	041-0250-18	Nut	1	20	053-0792-00	Insulator	1
6	040-0010-75	Screw	1	21	053-0295-01	Standoff	3
7	040-0006-04	Screw (Apply Loctite #042-0024-00)	6	22	041-0010-04	Locknut	2
8	002-0369-02	Display PC Board	1	23		Temperature Probe Assembly (Refer to "Plumbing & Sensor Components" Elsewhere)	Ref
9	053-0454-00	Display Gasket	1	24	H98137	Gasket	2
10	061-0531-00	Display Overlay	1	25	002-0505-00	Heat Element (Includes Gaskets)	1
11		Harness - PCB/Printer (Refer to "Printer Components" Elsewhere)	1	26	H97971	Washer	2
12	015-1096-00	Flat Cable EMI Suppression Core (Used On Certain Export Units)	1	27	045-0001-56	Lockwasher	2
13	040-0010-46	Screw	1	28		Nut (Included with Item 26)	2
14	015-0657-00	PCB/Heater Harness	1	29	050-3503-00	Thermostat Bracket	1
15		Switch Assembly (Refer to "Pressure Vessel Components" Elsewhere)	Ref	30	053-0389-01	Printer Harness Clip	1

Always Specify Model & Serial Number

Electrical Components

SECTION VI PARTS LIST M11 / M11D

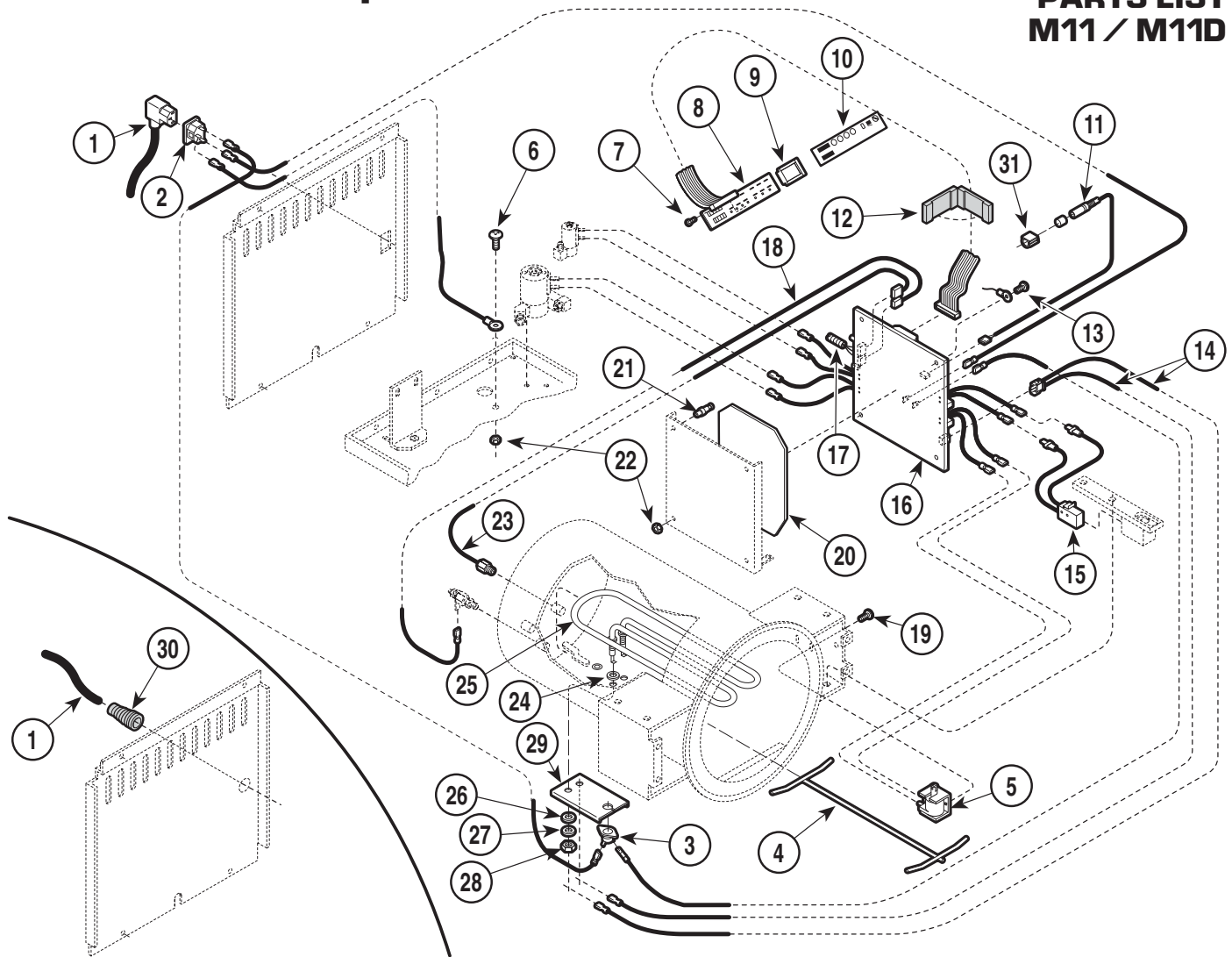

MA374708

Used on units with Serial Numbers:

ES7393, ET10312, FP1144, FR1357, GB1129, GC1156, GD1193, NP1000 - thru present

Item	Part No.	Description	Qty.	Item	Part No.	Description	Qty.
1		Cordset (Refer to W/D in Section 5) ...	Ref	16		Control PC Board (Refer to "Control PC Board" Elsewhere)	Ref
2	015-0639-00	AC Receptacle (230V. Units Only)	1	17	015-0257-02	Flex Guard Tubing	1
3	002-0370-00	Thermostat	1	18	015-0654-00	Chamber Level Sensor Harness	1
4	057-0426-00	Spacer Assembly	1	19	040-0010-74	Screw (M11 only)	2
5	002-0363-03	Solenoid-{120V} (M11 only)	1	20	053-0792-00	Insulator	1
	002-0363-04	Solenoid-{230V} (M11 only)	1	21	053-0295-01	Standoff	3
6	040-0010-75	Screw	1	22	041-0010-04	Locknut	2
7	040-0006-04	Screw (Apply Loctite #042-0024-00)	6	23		Temperature Probe Assembly (Refer to "Plumbing & Sensor Components Elsewhere)	Ref
8	002-0369-02	Display PC Board	1	24	H98137	Gasket	2
9	053-0454-00	Display Gasket	1	25	002-0505-00	Heat Element-{120V} (Incl. Gaskets)	1
10	061-0272-01	M11 Display Overlay	1		002-0505-01	Heat Element-{230V} (Incl. Gaskets)	1
	061-0531-00	M11D Display Overlay	1	26	H97971	Washer	2
	061-0272-00	M11 Display Overlay (metric)	1	27	045-0001-56	Lockwasher	2
	061-0272-02	M11 Display Overlay (French)	1	28		Nut (Included with Item 26)	2
11		Harness - PCB/Printer (Refer to "Printer Components" Elsewhere)	1	29	050-3503-00	Thermostat Bracket	1
12	015-1096-00	Flat Cable EMI Suppression Core (Used On Certain Export Units)	1	30	015-1137-00	Strain Relief Bushing (120V. Units Only) ..	1
13	040-0010-46	Screw	1	31	053-0389-01	Printer Harness Clip	1
14	015-0657-00	PCB/Heater Harness	1				
15		Switch Assembly (Refer to "Pressure Vessel Components" Elsewhere)	Ref				

Always Specify Model & Serial Number

M11 / M11D Control PC Board

SECTION VI PARTS LIST M11 / M11D

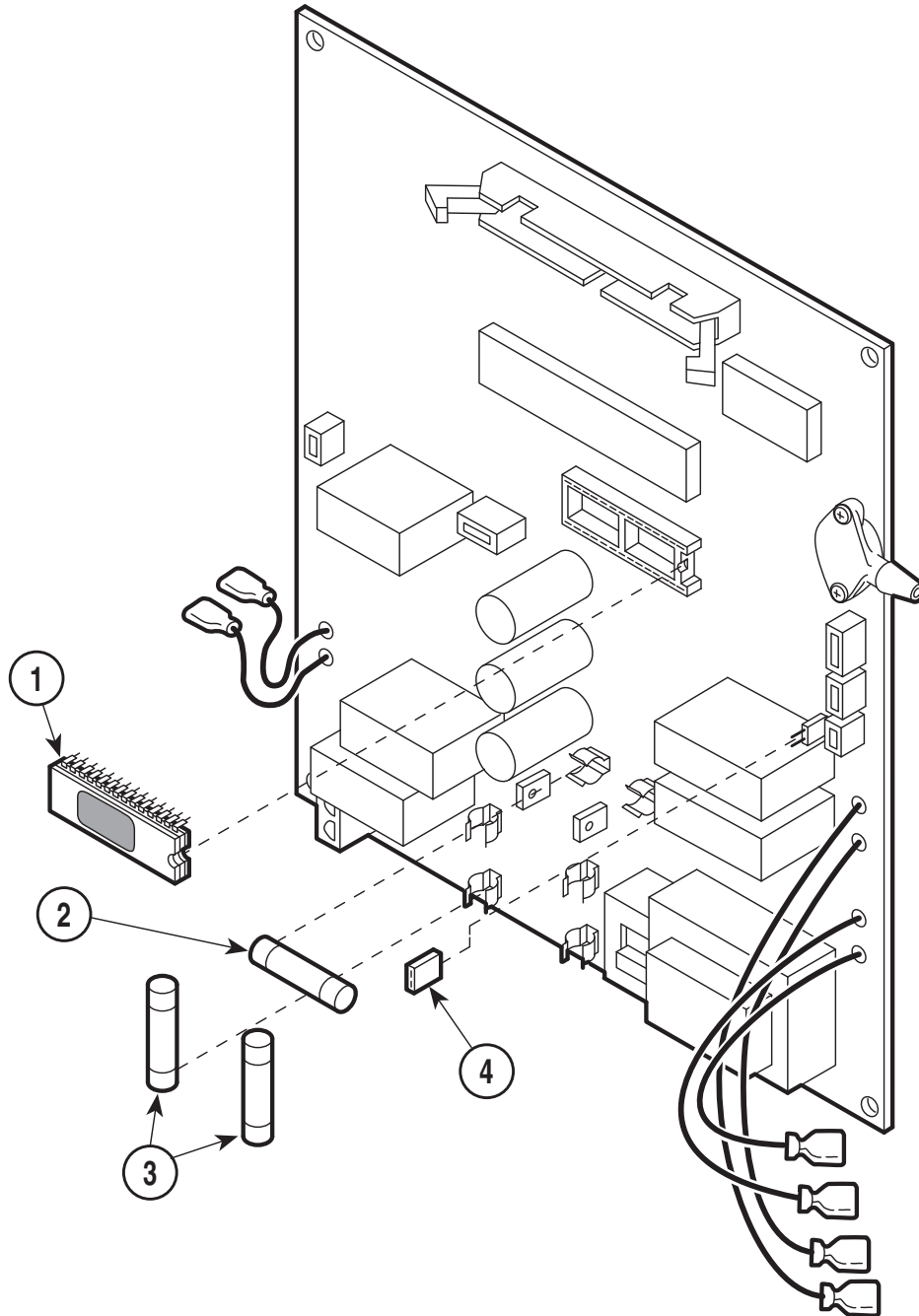

ATTENTION

Control PC board is no longer available.

Please contact Midmark Technical Service for information about the PC board rebate program.

(Some restrictions may apply)

MA22001

Item	Part No.	Description	Qty.	Item	Part No.	Description	Qty.
•		Control PC Board - 115 V & 230V (includes items 1 thru 4)	2	•	015-0346-08	• Printer Fuse (3 amp/250 V)	1
1	•	• M11 EPROM	Ref.	3	015-0346-07	• Line Fuse (15 amp/250 V) {Used on 115 V Units Only}	2
				4	•	• 2 Position Jumper	Ref

Always Specify Model & Serial Number

M11 Labels and Decals

SECTION VI PARTS LIST M11 / M11D

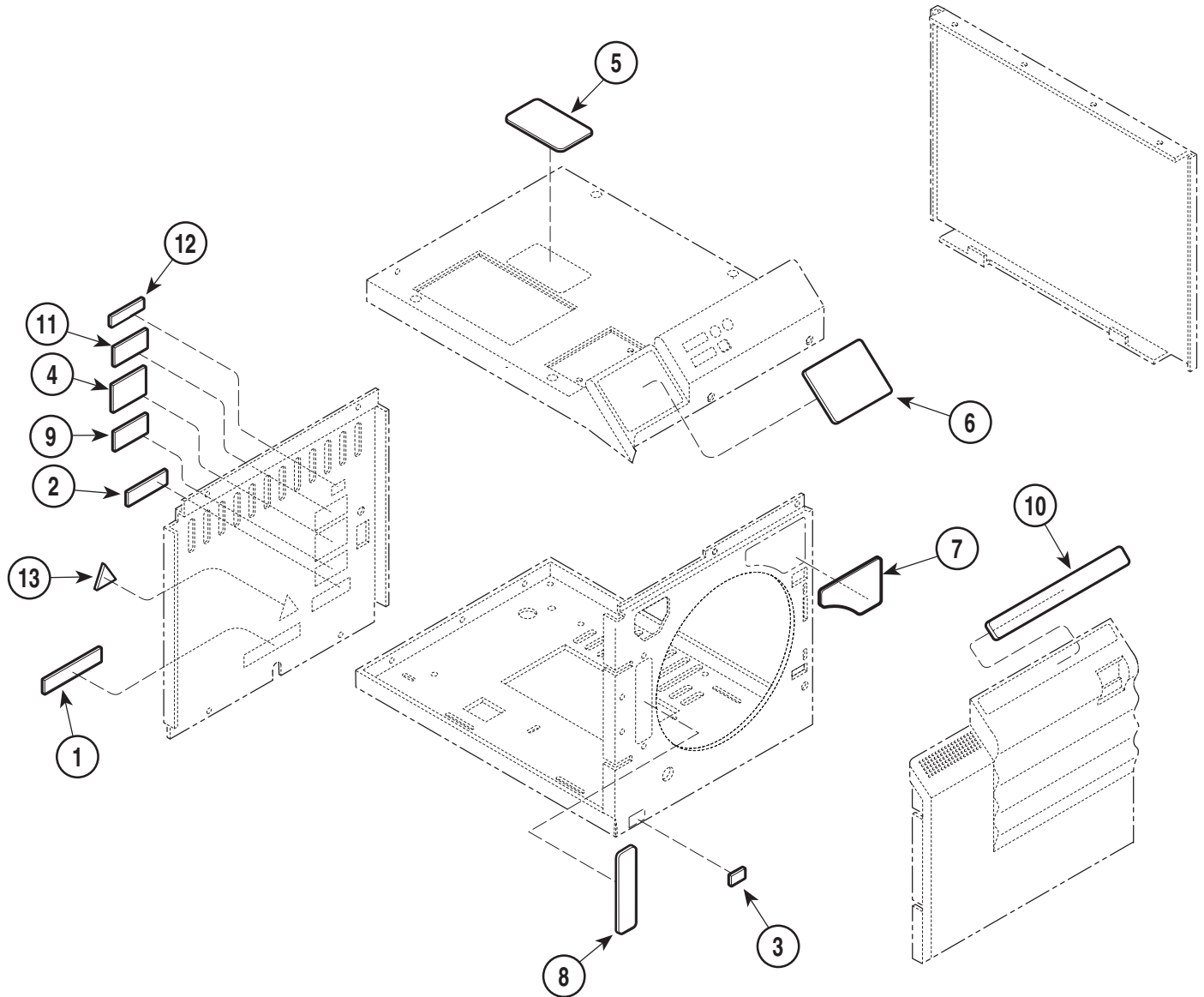

MA202512

Item	Part No.	Description	Qty.	Item	Part No.	Description	Qty.
1	061-0203-00	Electrical Shock Label (English)	1	8	061-0311-00	Water Level Label	1
	061-0516-00	Electrical Shock Label (French)	1	9	061-0624-00	UL/CUL 507U Label (Used on select units only)	1
2	061-0477-00	Patent Label	1	10	061-0441-00	M11 Operation Label (English)	1
3		Serial Number Label (Front)	1		061-0513-00	M11 Operation Label (French)	1
4		Serial Number Label (Rear)	1	11	061-0782-00	CE Representative Label (Used on select units only)	1
5	061-0309-00	M11 Warning Label P.R. Valve(English) 1	1	12	061-0733-00	Label - C.E.	1
	061-0514-00	M11 Warning Label P.R. Valve(French) 1	1	13	061-0654-00	Caution Label	1
6	061-0381-00	M11 Warning Label (English)	1	14	004-0068-00	Laminated Instruction Sheet (Not Shown) 1	
	061-0512-00	M11 Warning Label (French)	1	15	004-0254-00	Quick Reference Sheet (Not Shown)	1
7	061-0726-00	Hot Surface Label	1				
	061-0515-00	Caution / Hot Label (French)	1				

Always Specify Model & Serial Number

M11D Labels and Decals

SECTION VI PARTS LIST M11 / M11D

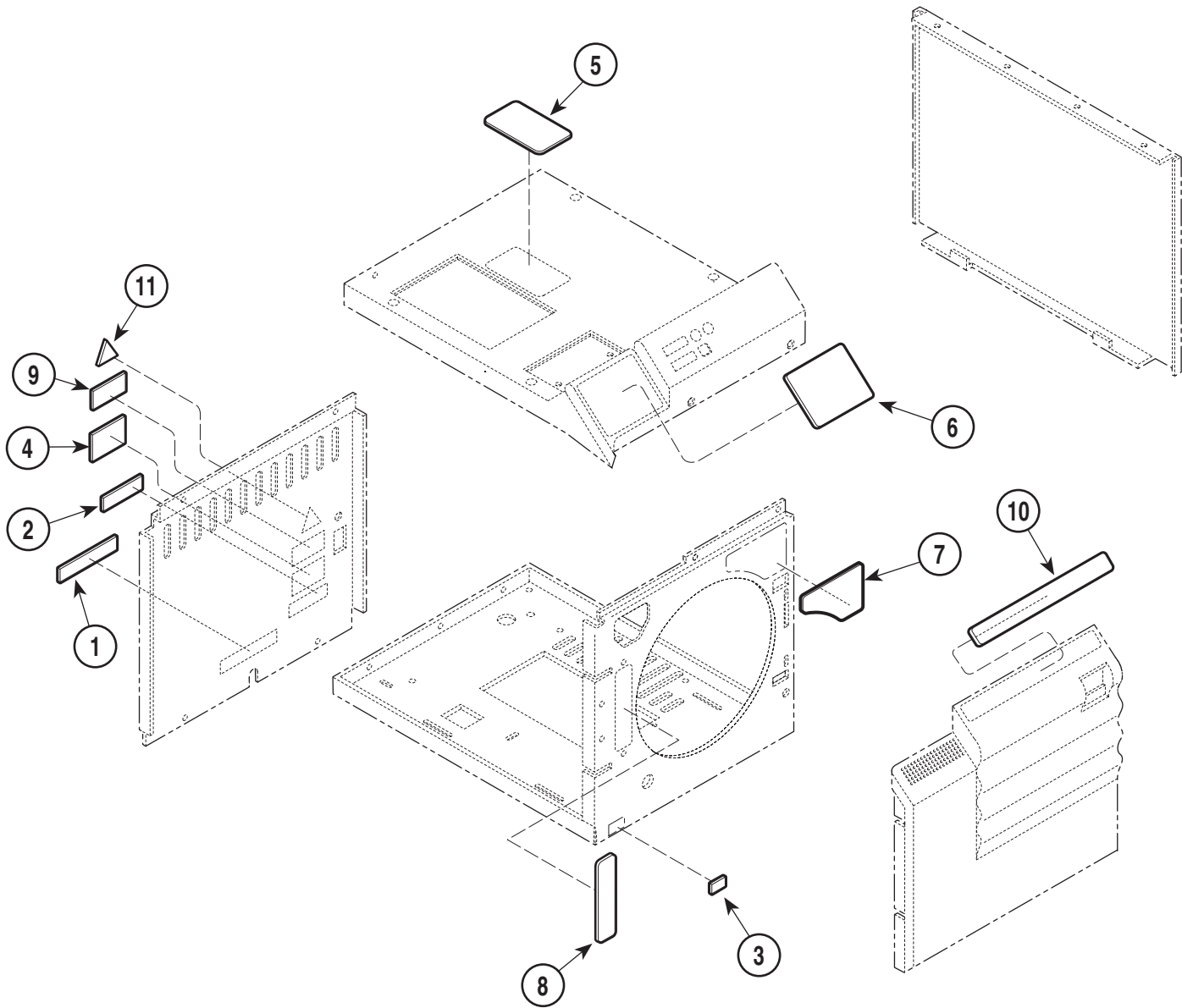

Item	Part No.	Description	Qty.	Item	Part No.	Description	Qty.
1	061-0203-00	Electrical Shock Label	1	8	061-0311-00	Water Level Label	1
2	061-0477-00	Patent Label	1	9	061-0624-00	UL/CUL 507U Label	1
3		Serial Number Label (Front)	1	10	061-0533-00	Operation Label	1
4		Serial Number Label (Rear)	1	11	061-0654-00	Caution Label	1
5	061-0309-01	Warning Label P.R. Valve	1	12	004-0068-00	Laminated Instruction Sheet (Not Shown)	1
6	061-0532-00	Warning Label	1	13	004-0254-00	Quick Reference Sheet (Not Shown)	1
7	061-0726-00	Hot Surface Label	1				

Always Specify Model & Serial Number

MA202511

Printer Components

SECTION VI PARTS LIST M11 / M11D

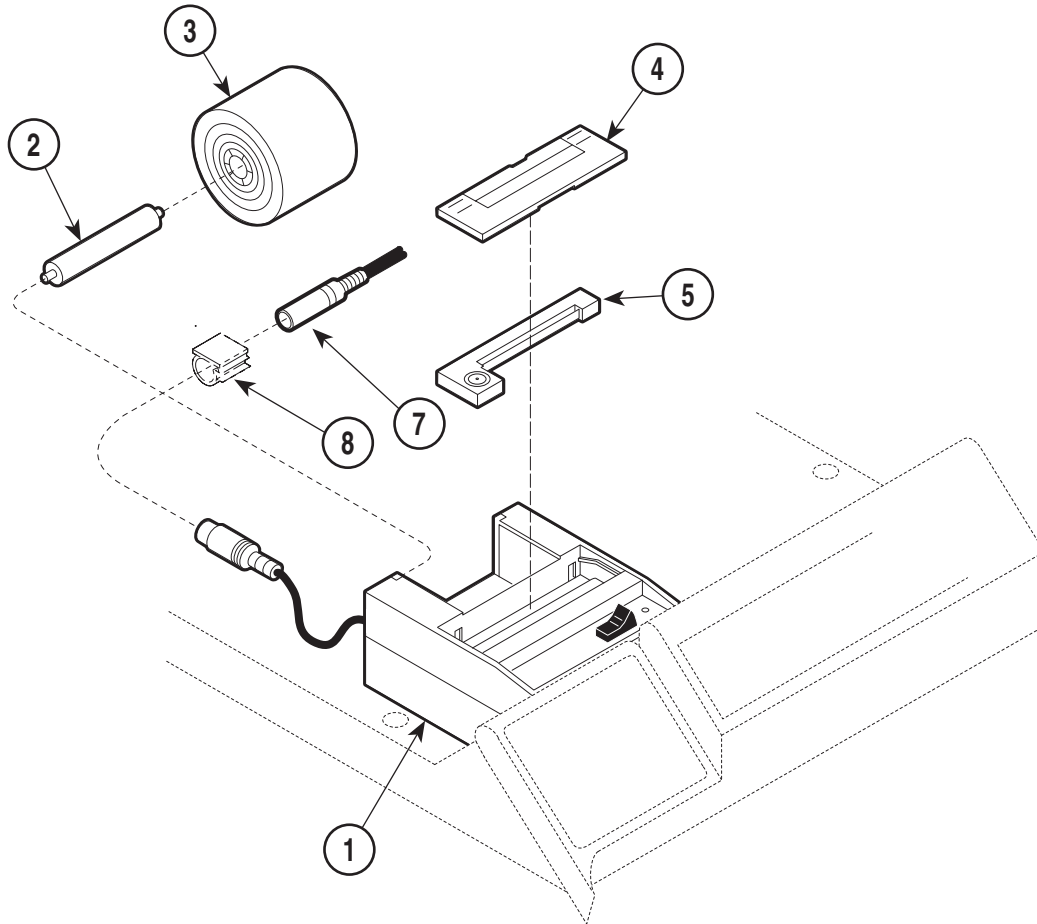

Item	Part No.	Description	Qty.	Item	Part No.	Description	Qty.
1	9A155001	Accessory Printer (Incl. Items 2 thru 7)	1	6	• 002-0371-00	• Cartridge/Paper Kit (Includes Two Rolls of Paper and One Cartridge)	1
2	• 053-0506-00	• Arbor	1	7	• 015-0978-00	• Printer Wiring Harness	1
3	• 060-0008-00	• Paper Roll	1	8	• 053-0389-01	• Printer Harness Clip	1
4	• 053-0507-00	• Cover	1				
5	• 053-0505-00	• Printer Cartridge	1				

Always Specify Model & Serial Number

Racks, Trays, and Cleaner

SECTION VI PARTS LIST M11 / M11D

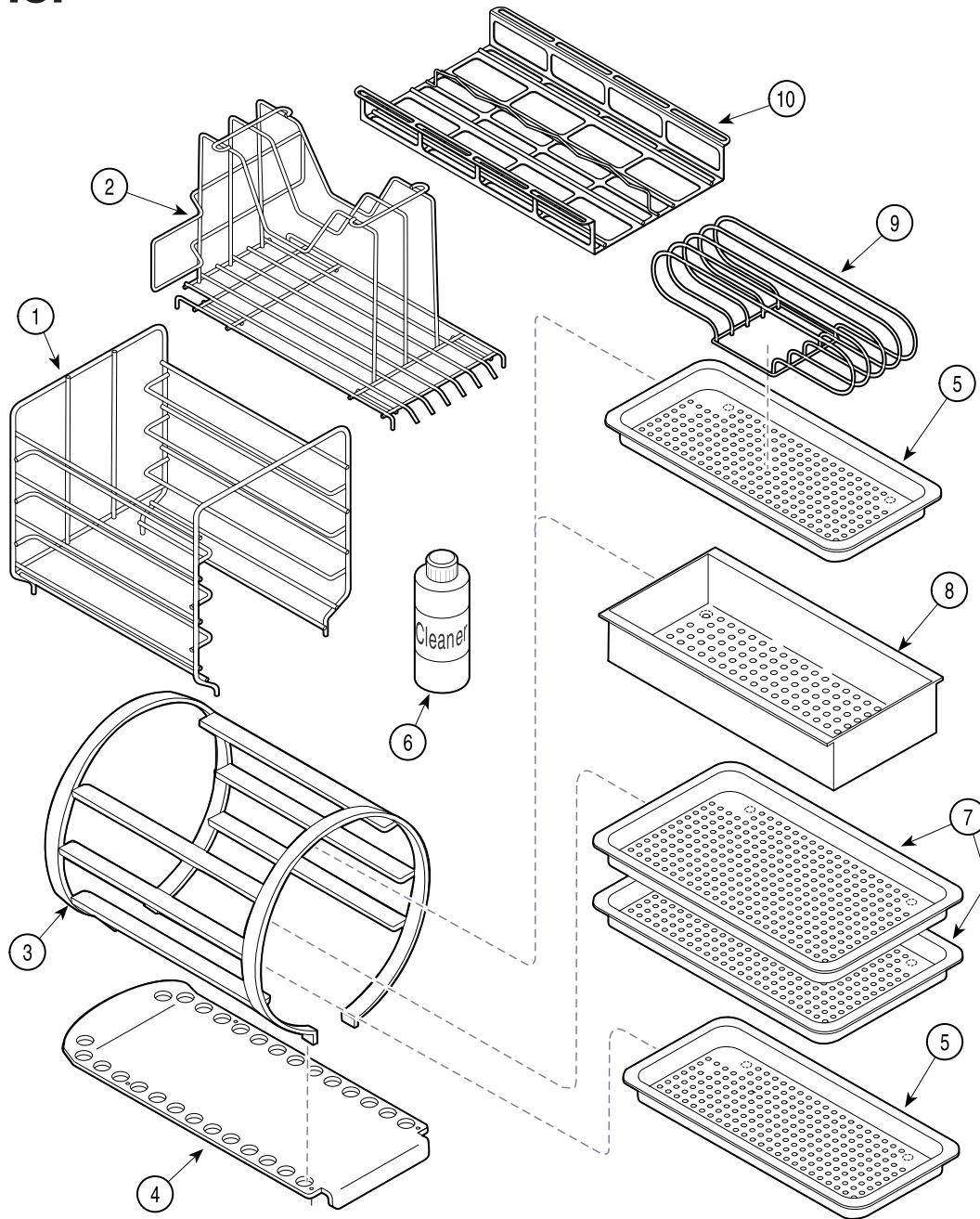

MA203205

Used on units with Serial Numbers:

ES1000 thru ES5001
GB1000 thru GB1109

ET1000 thru ET6434
GC1000 thru GC1074

FP1000 thru FP1073
GD1000 thru GD1068

FR1000 thru FR1204

Item	Part No.	Description	Qty.	Item	Part No.	Description	Qty.
1	9A215001	M11 Horizontal Cassette Rack Acces. ...	1	002-0396-00	Sterilizer Cleaner-Midmark (Single Bottle with M.S.D. Sheet)	AR	
2	9A215002	M11 Vertical Cassette Rack Acces.	1	002-0396-01	Sterilizer Cleaner-Midmark (12 Bottle Case with M.S.D. Sheet)	AR	
3	050-3920-00	Wire Tray Rack	1	7	050-2643-00	Large Tray	2
4	050-3919-00	Tray Plate	1	8	9A225001	Sterilizer Deep Tray	1
5	050-2644-00	Small Tray	2	9	9A226001	Sterilizer Pouch Rack	1
6	002-0269-00	Sterilizer Cleaner-Ritter (Single Bottle with M.S.D. Sheet)	AR	10	9A306001	Large Cassette Tray	1
	002-0269-01	Sterilizer Cleaner-Ritter (12 Bottle Case with M.S.D. Sheet)	AR				

Always Specify Model & Serial Number

Racks, Trays, and Cleaner

SECTION VI PARTS LIST M11 / M11D

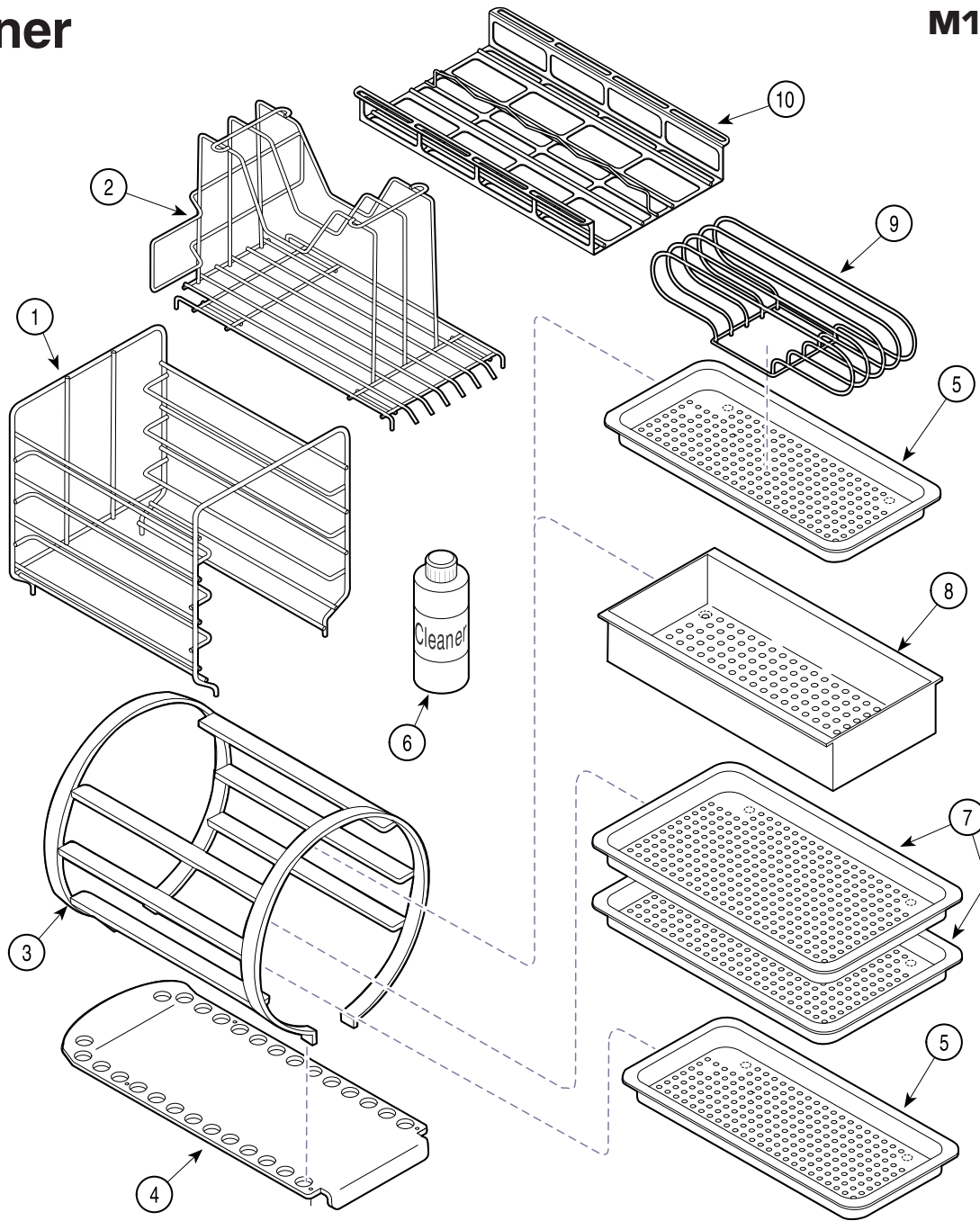

MA203205

Used on units with Serial Numbers:

ES5002, ET6435, FP1074, FR1205, GB1110, GC1075, GD1069, NP1000 - thru present

Item	Part No.	Description	Qty.	Item	Part No.	Description	Qty.
1	9A215001	M11 Horizontal Cassette Rack Acces. ...	1		002-0396-00	Sterilizer Cleaner-Midmark (Single Bottle with M.S.D.Sheet)	AR
2	9A215002	M11 Vertical Cassette Rack Acces.	1		002-0396-01	Sterilizer Cleaner-Midmark (12 Bottle Case with M.S.D.Sheet)	AR
3	050-3920-00	Wire Tray Rack	1	7	050-4259-00	Large Tray	2
4	050-3919-00	Tray Plate	1	8	9A225001	Sterilizer Deep Tray	1
5	050-4260-00	Small Tray	2	9	9A226001	Sterilizer Pouch Rack	1
6	002-0269-00	Sterilizer Cleaner-Ritter (Single Bottle with M.S.D.Sheet)	AR	10	9A306001	Large Cassette Tray	1
	002-0269-01	Sterilizer Cleaner-Ritter (12 Bottle Case with M.S.D.Sheet)	AR				

Always Specify Model & Serial Number

Packaging

SECTION VI PARTS LIST M11 / M11D

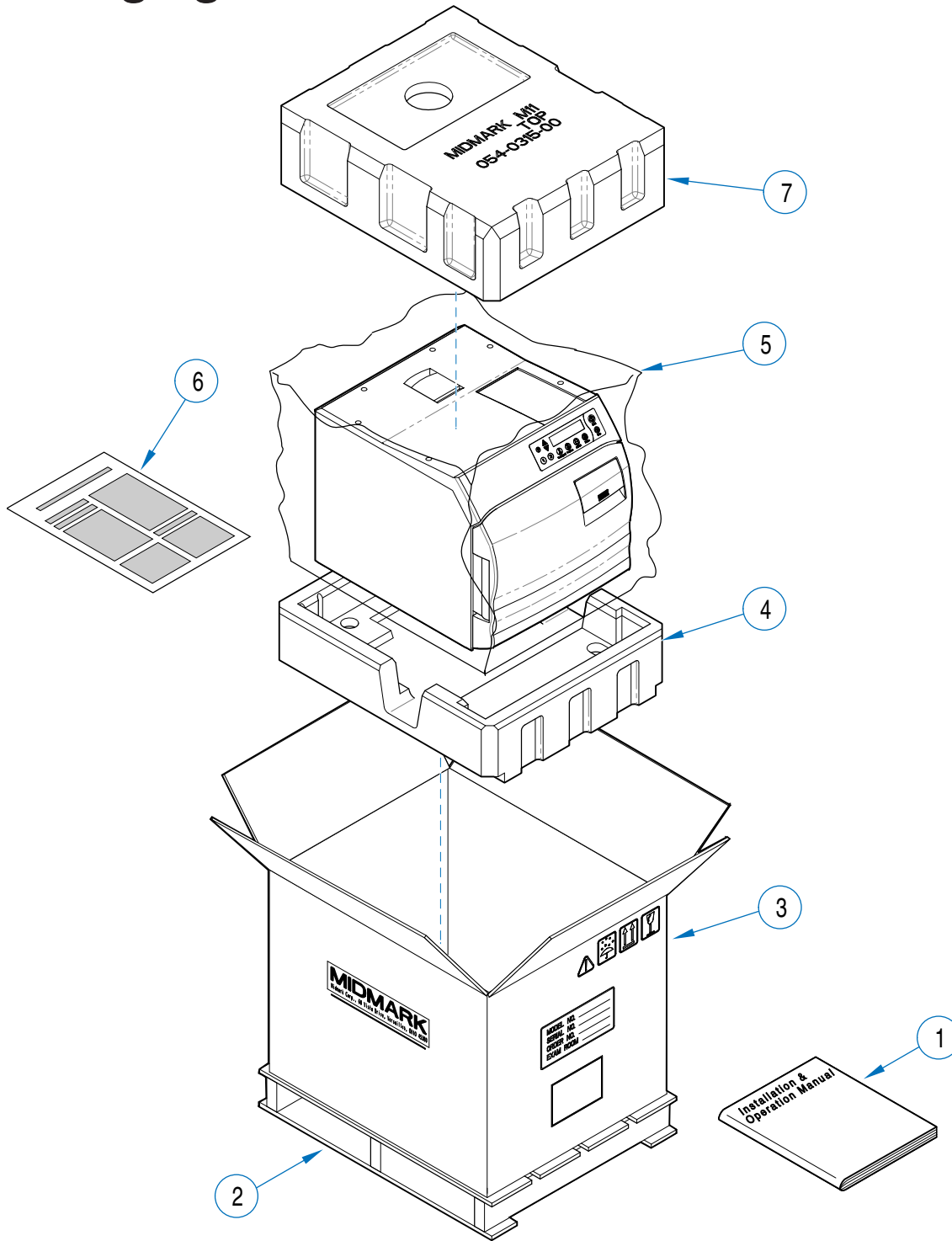

MA202405

Item	Part No.	Description	Qty.	Item	Part No.	Description	Qty.
1	003-1030-00	M11 Installation & Operation Manual	1	8b	061-0719-01	Label, Ritter (Not Shown)	2
	003-1032-00	M11D Installation & Operation Manual	1	8c	061-0719-02	Label, EMS (Not Shown)	2
2	063-9983-00	Skid	1		002-0531-00	Packaging Kit - Ritter (incl. items 2,3,4,5,6,7, 8b)	Ref
3	066-0844-00	Cardboard Box	1		002-0531-01	Packaging Kit - Midmark (incl. items 2,3,4,5,6,7, 8a)	Ref
4	054-0317-00	Bottom Pad (includes item 7)	1				
5	053-0061-01	Poly Bag	1				
6	077-0033-00	Speed Clean Material Data Safety Sheet	1				
7	054-0317-00	Top Pad (includes item 4)	1				
8a	061-0719-00	Label, Midmark (Not Shown)	2				

Always Specify Model & Serial Number

COMMENTS

The Technical Publications Department of Midmark Corporation takes pride in its publications. We are sure that our manuals will fill all of your needs when you are performing scheduled maintenance, servicing, or repairs on a Midmark product.

However, if you find any errors or feel that there should be a change, addition, or deletion to a manual, please let us know!

Page(s) and Paragraph(s) Needing Changed:

Description of Error or Desired Change:

Please fax or mail a copy of this completed comment sheet to:

Midmark Corporation
ATTN: Technical Publications Department
60 Vista Drive
Versailles, Ohio 45380
Fax: (937) 526-5542

FAX ORDERING FORM

(SERVICE PARTS ONLY)

NOTES:

- ALL **BLOCKED** AREAS MUST BE COMPLETED.
- USE FOR NON-WARRANTY FAX ORDERS ONLY. WARRANTY ORDERS MUST BE TELEPHONED IN (1-800-MIDMARK).

ATTENTION: SERVICE DEPARTMENT FAX#: 877-249-1793				
ACCT #: _____	P.O. #: _____	DATE: _____		
NAME: _____	SHIP TO: _____			
ADDRESS: _____	_____			
CITY, ST.: _____	_____			
CONTACT: _____	_____			
PHONE: _____	_____			
<input type="checkbox"/> NON-EMERGENCY ORDER - TO SHIP WITHIN 72 HOURS IF PART(S) IN STOCK.		METHOD OF SHIPMENT <u>OTHER</u> _____		
<input type="checkbox"/> EMERGENCY ORDER - TO SHIP WITHIN 24 HOURS IF PART(S) IN STOCK (IF ORDER IS RECEIVED BEFORE 1:00 P.M. E.S.T).		UPS <input type="checkbox"/> NEXT DAY A.M. <input type="checkbox"/> NEXT DAY P.M. <input type="checkbox"/> 2ND DAY <input type="checkbox"/> GROUND	FED EX <input type="checkbox"/> NEXT DAY A.M. <input type="checkbox"/> NEXT DAY P.M. <input type="checkbox"/> 2ND DAY <input type="checkbox"/> ECONOMY	
SEND NOTIFICATION IF PARTS ARE NOT AVAILABLE TO SHIP WITHIN 24 HOURS VIA E-MAIL OR FAX TO: _____				
QTY.	PART #	DESCRIPTION (SPECIFY COLOR OF ITEM IF APPLICABLE)	COLOR CODE	PRICE/PER
			TOTAL COST: \$	

Midmark Corporation
60 Vista Drive
P.O. Box 286
Versailles, Ohio 45380-0286
937-526-3662
Fax 937-526-5542
midmark.com



Because we care.

Subject to change without notice.
Refer to www.Documark.com for latest revision.