

SuperRotax tilts to allow fast and easy loading of vehicle. Put a vehicle into 4 sill clamps and your ready to pull in about 15 minutes.

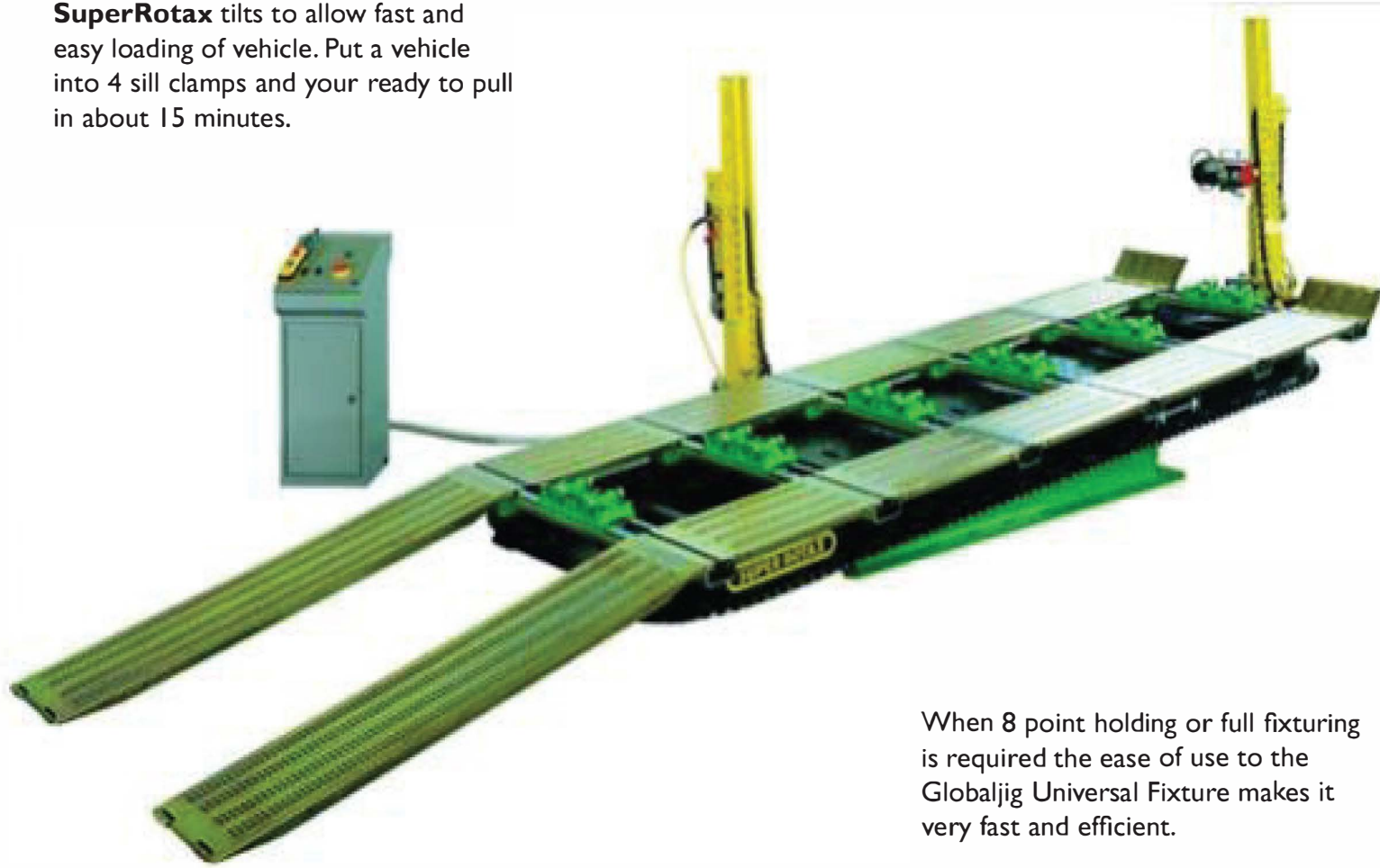

When 8 point holding or full fixturing is required the ease of use to the Globaljig Universal Fixture makes it very fast and efficient.



SUPER ROTAX

“ABSOLUTE PERFECTION”

GLOBALJIG PRESENTED BY **CHIEF**

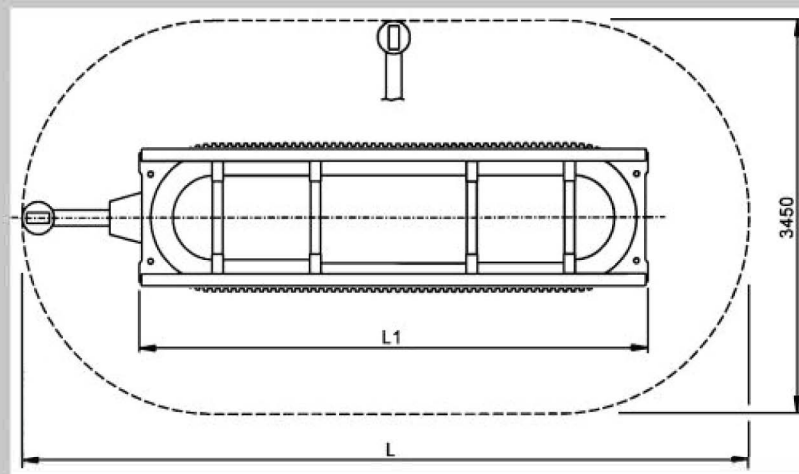

FOOTPRINT

L	L
5m	25.4 ft.
6m	28.7 ft

Super Rotax is available in 5m (16.4 ft) length or 6m (19.7 ft) length

GLOBALJIG PRESENTED BY **CHIEF**

996 Industrial Drive
Madison, Indiana 47250

salesorders@chiefautomotive.com
800.445.9262

SUPER ROTAX

“ABSOLUTE PERFECTION”

The Super Rotax system comes standard with the full Globaljig Universal Jig (12 pts) with storage cart, the McPherson Overhead Measuring Bridge, loading ramps, loading stands, winch and one pulling tower fitted with accessories.



COMPLETE SYSTEM

UNSURPASSED EVEN IN HEIGHT - A FULL 5.75 FT

MONOCUBE JIG

PULLING TOWER

LOCKING CROSSBEAMS

ARTICULATED PULLING TOWER

LIFT

FULL FRAME HOLDING

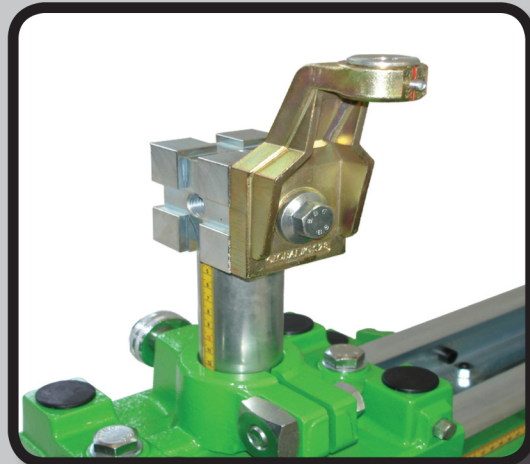

The patented Monocube Jig block saves 75% of the time required to install the jigs to the vehicle. Machined from one solid piece they have unsurpassed strength and a lifetime warranty.

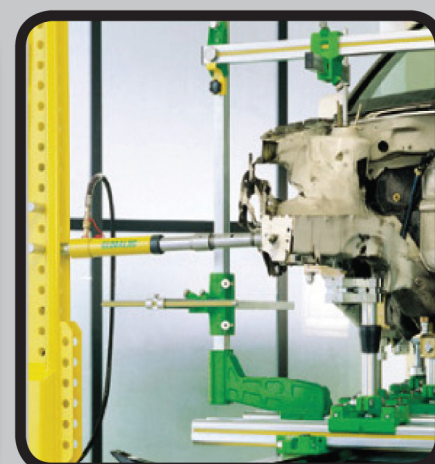

The 10 ton vector pulling towers glide effortlessly 360 degrees around the bench and can even be used to push from.

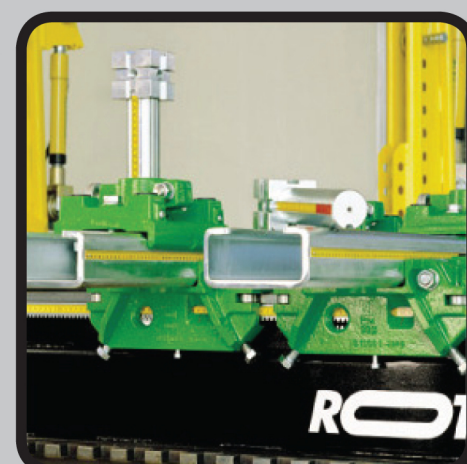

The crossbeams lock and unlock with a few turns of a bolt. A vehicle can be easily moved before and after on the bench even when it is tied to the clamps and fixtures



The optional articulated pulling tower when paired with the stand tower, allows both towers to be placed near each other for two simultaneous and close pulls.



High performance scissor lift can raise 7,700 lbs to adjustable working heights of up to 5 ft. 9 in. and has a full mechanical safety lock.

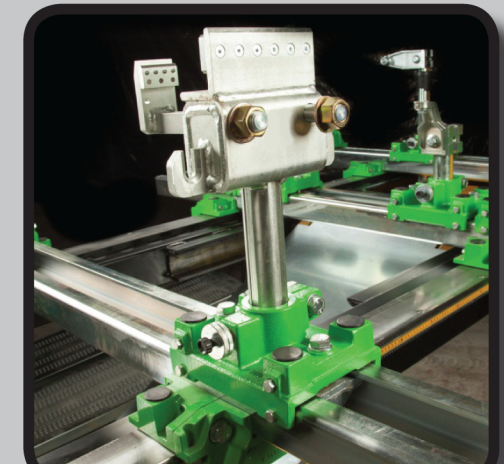

Optional full frame holding clamps can be used for truck and SUV frame repairs, alone or with the added benefit of fixtures also for the ultimate holding capabilities.