



# BFCMA

BRITISH FLUE & CHIMNEY  
MANUFACTURERS  
ASSOCIATION

## General Guidance on the selection and installation of flues and chimneys for wood burning and multi fuel appliances in residential properties.

This guide has been produced by the BFCMA to provide advice and general guidance on the selection and installation of chimneys and flues for maximum performance, safety and durability. It is important to ensure that the chosen chimney and the heating system, as a whole, are suitable for the purpose intended and conform to the relevant regulations and standards.

The BFCMA is the UK's only Trade Association representing manufacturers and sole UK distributors of factory made chimney and flue products. It was established to promote the advantages of chimneys and encourage continued improvements in standards, efficiency and service.

Contact details of BFCMA members are shown on the back page of this guide.

Published by the  
British Flue and Chimney Manufacturers Association.  
2 Waltham Court, Milley Lane, Hare Hatch, Berks, RG10 9TH.  
Tel: 0118 940 3416 Fax: 0118 940 6258 Email: [info@feta.co.uk](mailto:info@feta.co.uk)

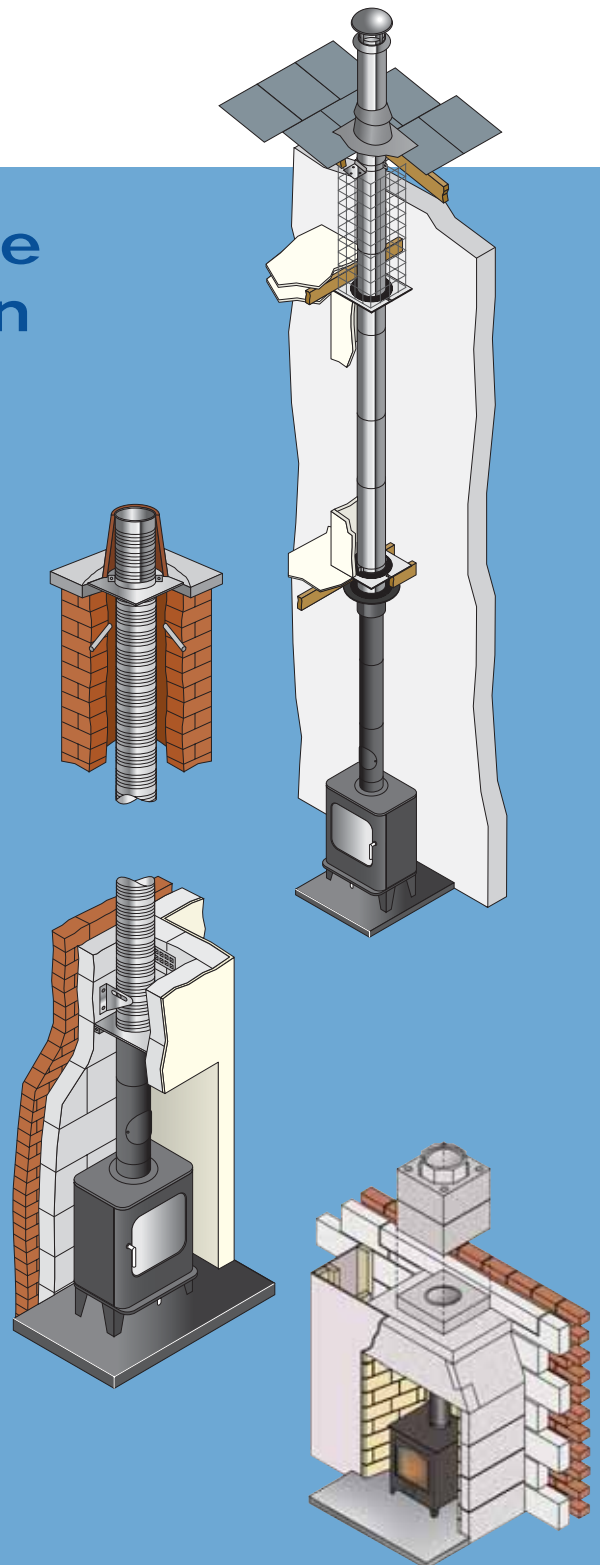

## Introduction

### Regulations

The construction and application of chimneys and flues is covered by UK Building Regulations in conjunction with the relevant European and British Standards. Whilst these differ in emphasis, they all mandate the safe application of the chimney no matter where and how used. These Regulations and Standards dictate the minimum criteria which it is necessary to apply if the chimney or flue is to function safely and correctly. Building control approval is necessary for building new chimneys and in some cases for relining old chimneys particularly if some alteration or change of the heating appliance occurs. The appropriate Regulations and Standards are listed later in this document.



### Chimney Principles

The terms flue and chimney are often used interchangeably. The flue is the working part of the chimney, conveying the products of combustion safely to the atmosphere. The chimney includes the shaft within which the flue is housed. A flue works under negative pressure drawing the product of combustion from the appliance.

A successful "chimney draw" is dependent on the following principles:

- The difference in air pressure between the appliance and the top of the chimney. (created by the height of the chimney)
- The difference in temperature between the appliance's exhaust gas and the outside temperature.
- The quality of insulation along the length of the chimney.
- The route of chimney. (The straighter and more vertical the chimney the better).

It is essential to choose a flue diameter that matches the output from the appliance. An adequate air supply is also required for the appliance to operate safely and efficiently.

# Types of Chimney and Flue Systems

---

The European Standard BS EN 1443: 2003 Chimneys – General Requirements, categorises chimneys and flues into three basic designations:

**Custom Built Chimneys** - Constructed on site using factory made flue liners.

**System Chimneys** - Prefabricated chimney systems. Manufactured in a factory and assembled on site. The key benefits of chimney systems lie in their off-site production and preformed insulation.

**Connecting Flue Pipes** - Pipe specifically designed to connect an appliance to the flue or chimney.

Chimneys and flues are also available in a number of different materials – stainless steel, concrete, pumice, clay or ceramic and plastic. Concrete, pumice and clay or ceramic are collectively referred to as masonry chimneys. Plastic flues are only allowed to be used with low temperature condensing applications.

Care must be taken to check the designation of stainless steel chimney systems and flexible liners as a limited number are specifically designed for use with gas fired appliances. These must not be used with wood burning or multi fuel appliances. Clay and pumice chimney systems and liners are suitable for wood, multi fuel, oil and gas. Concrete gas flue blocks as the name suggests are only to be used with gas effect fires and must not be used with wood or solid fuel fires.

Factory produced pumice and ceramic chimney systems are also available. Although they can be retrofitted, pumice and ceramic chimney systems tend to be used in new houses, because they require a foundation and their construction method is best suited to the skill set of a bricklayer.

## Stainless Steel Flexible Liners

Stainless steel flexible liners are certified to BS EN1856-2. Flexible liners are used to reline an existing chimney. Care must be taken when selecting a flexible liner.

There are two types of flexible liners:

- Single skin liners for use with gas appliances and
- Twin skin liners, manufactured from overlapping strips of high grade stainless steel to give a smooth sealed flue-way. These liners should be used with wood and multi-fuel appliances.

Single skin liners must never be used with wood or multi-fuel applications.



## Clay, Pumice and Concrete Liners.

Clay/ceramic flue liners are manufactured from a specially selected blend of fire clays in a range of sizes in both round and square to suit the range of wood and solid fuel appliances and open fires. BS EN 1457:2012 part 1 specifies the technical requirements for clay/ceramic liners to be used in dry, non-condensing conditions.

Pumice and concrete liners are certified to BS EN 1857:2010. The difference between concrete and pumice chimney products lies in the degree of pumice used in their manufacture. The Schiedel pumice liners, for example, are manufactured with 100% pumice aggregate. Cement is used to bind the aggregate with the result that the percentage of pumice in the finished product is still over 90%. Pumice is made from volcanic rock and its importance in chimney construction comes from the fact that it is a natural insulator.

To form a chimney, the liners have to be surrounded with at least 100mm thick brick, block or stonework with the gap in between filled with a suitable insulating concrete mix. Clay, pumice and concrete liners can be used to reline an existing chimney. Concrete and pumice liners should not be used with condensing applications.



## Stainless Steel System Chimneys

Stainless steel system chimneys consist of two concentric stainless steel metal walls with insulation filling the annular space between them. Some systems have a ceramic liner, which can offer a longer life. Factory made system chimneys are easy to handle and available with a wide range of fittings such as elbows, terminals and tees, all of which simple lock or push together. They are easily assembled and supported with purpose designed support brackets. These products, which can be used internally and externally, must be certified to BS EN 1856-1:2009.

Stainless steel systems tend to be used in existing buildings that do not have a chimney and extensions, because they do not require a dedicated foundation and can be easily retrofitted.



## Pumice Chimney Systems

Pumice chimney systems are certified to BS EN1858:2008. Double wall pumice chimney systems, known as Double Module, are able to exploit the natural insulating properties of pumice and do not require any further insulation. Pumice systems are lightweight and come with a range of accessories designed to facilitate use with stoves. Pumice chimney systems should not be used with condensing applications.



## Ceramic Chimney Systems

Ceramic chimney systems are certified to BS EN13063-1:2005. Ceramic chimney systems and liners are suitable for wood, multi fuel, oil and gas and condensing applications. The inner ceramic liner is insulated with rock wool and contained in a preformed concrete block.



## Gas Flue Block Systems

Gas Flue Blocks have been specifically designed for use with gas effect fires. They must not be used on a wood burning or multi fuel appliance under any circumstance. The concrete blocks have an integral narrow rectangular flue way. They are of the same modular size as a masonry building block and are usually designed so that they bond into adjacent brick or block work. Gas Flue Blocks certified to BS EN 1858:2008



## Connecting Flue Pipes

Connecting Flue Pipes are designed to connect the appliance to the flue. The pipe is usually decorative because it is visible in the living area. The options are vitreous enamel or single wall stainless steel. Single wall stainless steel is certified to EN1856-2. The vitreous enamel coating should comply with the recommended requirements for high resistance to heat in BS1344 part1:1994 part 7:1984 and acid resistance BSEN 14483-1:2004. The European Standard for vitreous enamel low carbon steel flue pipes is BS60009-1989.





## Stainless Steel Terminals, Birdguards & Anti-Downdraught Terminals

Stainless steel terminals are usually fitted for one of two reasons:

- **Weather, bird and debris protection.**

The terminal is designed so that it will not restrict the draw of the chimney.

- **Resolution of downdraught problems**

If downdraught is being experienced and other factors have been ruled out, a stainless steel anti-downdraught terminal can enhance the airflow and the performance of the chimney. Stainless steel anti-downdraught terminals are also designed to provide weather, bird and debris protection to the chimney.

Stainless steel terminals can be fitted to all types of flue and chimney installation in stainless steel, clay/ceramic, concrete and pumice chimney systems. They can be supplied either as part of the chimney system or can be obtained separately from reputable chimney terminal manufacturers

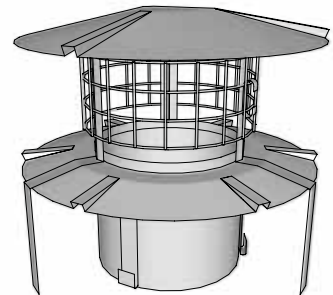
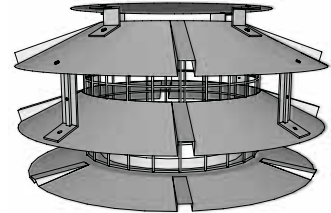

## Chimney Fans

Chimney fans are mechanical draft systems designed to resolve chimney draft problems. Systems are available for use with a wide range of appliances including wood burning and multi fuel stoves and open fires. Specialist advice should always be sought when selecting the appropriate draught solution. Chimney fans must operate in accordance with the requirements of BS EN 15287-1.



# Chimney and Flue Design

---

## Flue Sizing

It is important to match the internal diameter of the flue with the outlet on the appliance. It should never be less than the outlet diameter of the appliance. The appliance manufacturer's chimney sizing recommendations should always be followed. For free-standing stoves, boilers and cookers up to a maximum of 20KW, that are not in a fireplace recess, the minimum flue size is 125mm round or square if the appliance has passed the DEFRA requirements for smokless zones and 150mm if this is not the case.

For open fires with a standard fire opening up to 500mm wide by 550mm high the minimum required flue diameter is 200mm round or 175mm square. For larger open fires, such as inglenooks, dog grate installations or special appliances and stoves designed to operate with a fire opening greater than 500mm x 550mm, the flue size should be at least 15% of the free unobstructed area of the fire opening (including sides if open). Many Decorative Fuel Effect gas fires (DFE's) that imitate a coal or log burning open fire require the same chimney arrangement as for solid fuel open fires and must be installed in accordance with British Standard BS5871:Part 3:2005

It is worth noting that in SAP the assumed standing air loss for a flue with an internal diameter of 200mm and above is 40 cubic meters per hour. With a flue diameter of less than 200mm or a chimney system that incorporates a damper the ventilation rate is halved to 20 cubic meters per hour. (The damper must only be closed when the appliance is not in use). This can have a significant impact on the energy rating of a house.

SAP is the Standard Assessment Procedure used to calculate the overall energy efficiency and carbon output of a house.

## Insulation is Key

One of the keys to a well performing chimney is consistent insulation along the complete length of the flue. Clay/ceramic, concrete and pumice liners require insulation to be prepared and added on site. Stainless steel and ceramic system chimneys are supplied with effective insulation. Double wall pumice chimney systems have an air gap between the walls of the inner and outer block. The air gap combined with the natural insulating properties of pumice provide effective insulation along the length of the chimney.

SAP is the Standard Assessment Procedure used to calculate the overall energy efficiency and carbon output of a house.

## Chimney Position

The ideal location for a chimney is on the inside of the building. That way it can benefit from being kept warm. Chimneys situated outside the building can be affected by cold weather causing poor up draught and condensation, particularly if they are un-insulated. It is therefore important that a cavity wall is continued around a lined masonry chimney or a factory made insulated chimney system is used for external applications.

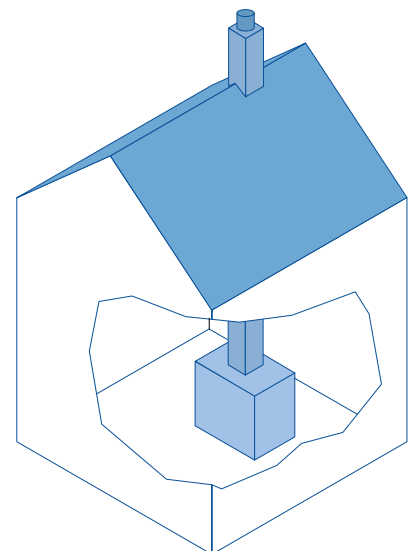

## Bends in the Chimney

Both the Regulations and the Standards recommend that bends in the chimney be avoided, as a straight vertical chimney performs better. If bends are necessary there must be no more than four in the length of the chimney. The angle of the bend should be no greater than 45° from the vertical, with the exception that 90° factory made bends or tees may be treated as being equal to two 45° bends. Where System Chimneys are used, always use the standard offset components which are available from the chimney manufacturer. For stainless steel chimneys, certified to BS EN 1856, the distance between bends must be no greater than 20% of the total chimney length. It is recommended that a vertical rise of 600mm should be allowed immediately above the appliance before any change of direction. An inspection hatch is required between each offset.

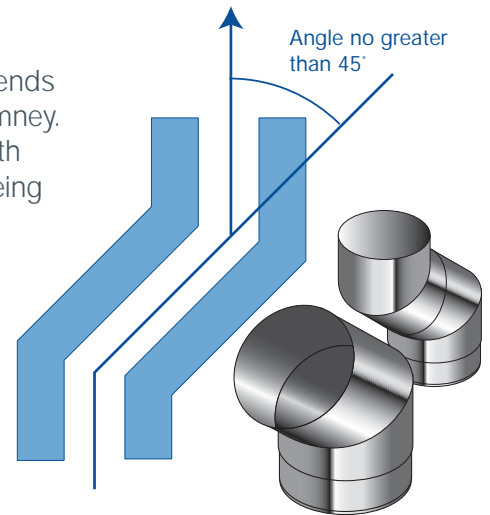

## Connection to the Chimney

Stoves, cookers and boilers should be connected to the chimney using correctly sized metal steel flue pipe which conforms to BS EN 1856-2:2009, or with alternative materials identified by Building Regulations such as Vitreous Enamelled flue pipe certified to BS 6999:1989. The connecting flue pipe must be suitably sealed with spigot end facing down (into the socket of the pipe below). As excessive bends and horizontal runs can accumulate soot with the risk of blockage, the flue pipe should be kept as vertical as possible and the angle of bends should be no more than 45° from the vertical. In the current Document J the maximum horizontal length of flue pipe allowed from the back of an appliance into any chimney is 150mm. It is important that there is easy access for cleaning, particularly at any change of direction in the flue.

For open fires a suitable throated front lintel and gather must be installed above the fire opening, so that the front, back and sides slope up smoothly into the flue opening in the chimney at an angle no greater than 45° from the vertical. Flat surfaces or shelves must be avoided as these can cause turbulence and smoky fires. Most flue and chimney manufacturers provide standard gather and fireplace components. Precast fire chambers or Firechests are also available for standard and larger fire openings.

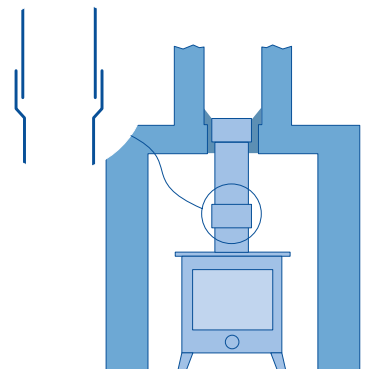

## Access for Chimney Inspection and cleaning

Some appliances, such as free-standing stoves and inset fires, have built in gathers or removable baffle plates to allow sweeping through the appliance. Building Regulations require that the connecting pipe is easily accessible for regular inspection and sweeping to prevent blockage. If this is not possible through the appliance, a purpose made access/soot door must be provided in the chimney. Most chimney manufacturers can provide components to suit. Where the connecting flue pipe goes into the side of the chimney a space must be provided with soot door access below this point to collect debris, such as soot, that may fall down the chimney.



## Chimney Pots and Terminals

There are many types of chimney pots and terminals, in different styles and shapes to suit almost any taste and application. However, it is important to ensure the chosen pot or terminal does not restrict the exit of the products of combustion. The area of the outlet must be at least the same as the flue area. If the terminal has a hood the area of the outlet should be twice the flue area. Beware of terminals which are primarily designed for ventilating a chimney where the fireplace has been closed off.

An open termination is normally recommended for wood burning and multi-fuel appliances. However rain caps or anti-downdraught terminals may be used. Rain caps and anti-downdraught terminals are available in two versions, with anti-bird mesh and without mesh. Where a terminal with mesh is used, there is a risk of soot build up, and therefore regular cleaning is required to avoid blockage.

If there is a “down draught” from the chimney (i.e. smoke blown back into the room) it is best to check that there is nothing wrong with the chimney arrangement, before fitting a special terminal. The problem is often caused by factors such as lack of ventilation in the room, poor throating above the open fire or insufficient chimney height.

## Chimney Heights and Termination

The minimum chimney height recommended for minimum performance of wood burning and multi fuel appliances is 4.5 m from the top of the appliance to the top of the chimney. It is best to position the chimney, so that it goes straight up as near to the roof ridge as possible. The diagram below, taken from Document J, shows the minimum flue discharge heights and positions for all wood burning and multi fuel applications. In some cases, particularly when chimneys are towards the bottom of a sloping roof or at the eaves, it may be necessary to increase the chimney height above these minimum mandatory requirements. The reason for this is to clear pressure zones created by wind hitting the roof and nearby structures, like trees, which may interfere with the up draught required by the appliance or fire. The maximum freestanding stack height above the roof for a traditional masonry chimney is 5.4 times the narrowest horizontal part of the chimney. In the case of stainless steel system chimneys, the manufacturer’s installation instructions should be consulted; however in most cases it will be around 1.5 metres. This measurement is taken from the last point where the chimney stack passes the through or past the edge of the roof up to the chimney capping or termination. Tall chimneys may need bracing, always consult the manufacturer for advice.

Point where flue passes through weather surface (Notes 1,2)	Clearances to flue outlet
<b>A</b> At or within 600mm of the ridge	At least 600mm above the ridge
<b>B</b> Elsewhere on the roof (whether pitched or flat)	At least 2300mm horizontally from the nearest point on the weather surface and: a) at least 1000mm above the highest point of intersection of the chimney and the weather surface; or b) at least as high as the ridge
<b>C</b> Below (on a pitched roof) or within 2300mm horizontally to an openable rooflight, dormer window or other opening (Note 3)	At least 1000mm above the top of the opening
<b>D</b> Within 2300mm of an adjoining or adjacent building, whether or not beyond the boundary (Note 3)	At least 600mm above any part of the adjacent building within 2300mm

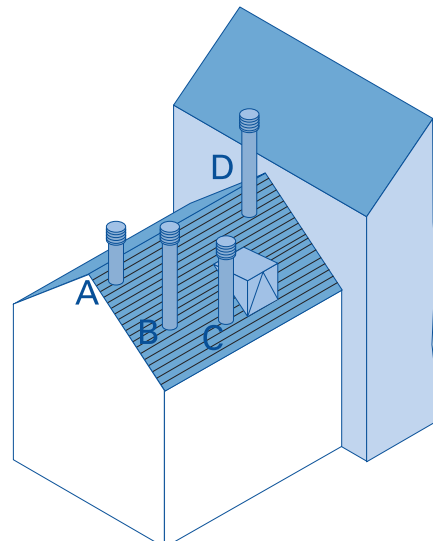

## Dwellings with a Thatch and Combustive Roof

These require special attention and should only be worked on by experienced installers. Attention is drawn to the HETAS guide on thatched properties. The home owner's insurance company must be advised of proposed works.

## Fan Assisted Flue Arrangements

The use of electrically powered fans to assist natural chimney draught is a subject that must be discussed with both the fan supplier and heating appliance manufacturers who will normally provide technical advice to ensure safe operation. Even in the event of fan failure, the products of combustion must still be able to safely evacuate the chimney, in accordance with BS EN 15287-1. The products of combustion will continue to be produced until the appliance is extinguished.

## Combustion Air Requirements

All heating appliances need air to work efficiently and safely. It is essential that the appropriate permanent air supply, as required by the appliance manufacturer and Building Regulations is provided into the room where the appliance or open fire is situated. Always refer to the appliance manufacturer's recommendations and Building Regulations before installation. An inadequate supply of combustion air can create problems. Situations assumed to be "down draught" and spillage of smoke and fumes back into the room, which can be unpleasant and dangerous, are more frequently caused by insufficient provision of combustion air. Either the openings have not been provided, are not large enough or have been simply blocked off. If the appliance does not get all the air it needs to burn the fuel efficiently, incomplete combustion will occur resulting in the production of carbon monoxide and, if badly deprived of air, copious volumes of soot.

## Carbon Monoxide Alarms

All wood burning and multi-fuel appliances should have a carbon monoxide alarm fitted within the same room as the appliance. The carbon monoxide alarm should comply with BS EN 50291-1:2010, and must be installed to the manufacturers' installation instructions, and current Buildings Regulations.

An alarm is required because carbon monoxide is a dangerous odourless and invisible gas.

# CE Designations

## Making Sense of CE Designations for Stainless Steel Flues

One of the key features of the European Standard for metal chimneys (EN 1856) is a user-readable classification system that designates the features of the product. A label showing the classification must go with each flue component. Understanding the classification can make the job of selecting the right flue much easier and will allow you to compare different flues. It's easy to use so long as you know the keys. The diagram below unlocks the coded information.

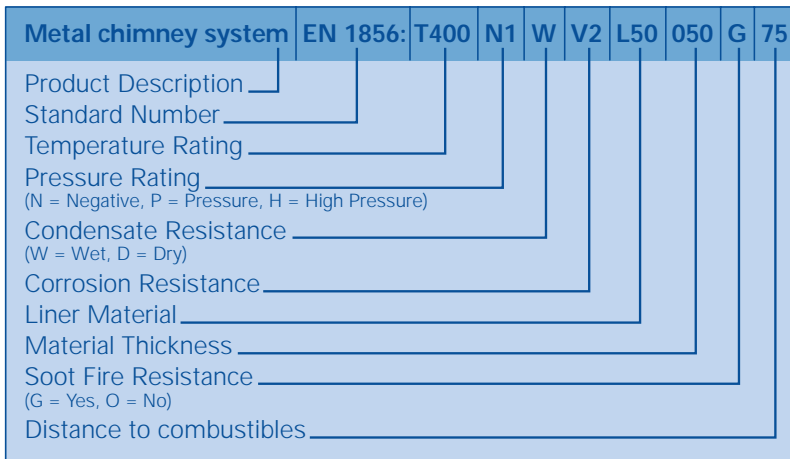

Picking out a few of the main points:

**Temperature Rating** Maximum temperature (°C) for continuous use of the flue. T400 is suitable for multi-fuel. T200 is suitable for gas and oil.

**Corrosion Resistance** This is fuel dependent as follows;

- V1** Resistant to attack from products of combustion from gas
- V2** Resistant to attack from products of combustion from light oil (sulphur content up to 0.2%) and natural wood. If the flue passes the V2 wet test then it is also deemed to comply with V3 under dry conditions.
- V3** Resistant to attack from products of combustion from heavy oil (sulphur content > 0.2%), solid fuels and peat
- VM** Not tested but rating declared by the manufacturer

**Liner Material and Thickness** 316L, is the highest quality grade and is expected to withstand the corrosion effect of multi-fuel, wood or heavy oil. The code for 316L is L50. Light oil is less corrosive and normally 304 (L20) has proved adequate in dry conditions, but in the increasingly common wet conditions created by high efficiency condensing boilers, the higher grade is required (316L). The thickness is the steel thickness in mm.

**Soot Fire Resistance and Distance to Combustibles** Expressed as either G, for soot fire resistance or O for not, followed by the declared minimum distance to combustibles expressed in mm. To obtain the G classification means that the product has been tested at 1000°C for 30 minutes and remains intact. The temperature of combustible material at the designated distance must not exceed 100°C at an ambient temperature of 20°C.

**Distance to Combustibles for Connecting Flue Pipe** Connecting flue pipes to BS EN 1856-2 also have an additional classification M (Measured) or NM (Not Measured). If not measured the minimum distance to combustibles should be 3 times the internal diameter of connecting flue pipe.

**Flue Testing** The flue should be fully tested in an enclosed combustible shaft.

## Making Sense of CE Designations for Clay/Ceramic Liners

The main change in the new standard for clay/ceramic flue liners, published in January, 2012, is the fact that the standard was split into two sections. BS EN 1457 part 1 is the standard for clay/ceramic flue liners operating under dry or non-condensing conditions. BS EN1457 part 2 covers liners operating under wet/condensing conditions. Under wet conditions condensation will be on the inside of the flue liners typically arising from the operation of modern and more efficient lower exhaust gas temperature appliances. The structure of the label is the same in both parts.

Clay/Ceramic liners	EN 1457-1:	300	A1N2	
Product Description				
Standard Number (either EN1457-1 or EN1457-2)				
Nominal diameter				
<p>The type of liner specifies the conditions under which the liner can be used. For wood burning and solid fuel appliances and open fires, operating under negative pressure in the chimney, the requirement is for soot fire resistant liners which are in the class A1N1 and A1N2. A1N2 will be the type of liner generally available. These liners are suitable for use at a working temperature of 600 °C. They can also withstand a soot fire of 1000 °C.</p>				
Condensate Resistance				
<p>If Certified for wet conditions under EN1457-2 there will be a W here.</p>				

## The CE Designation for Concrete Liners

The standard for concrete liners is BS EN 1857:2010. The types of liner are classified in a similar way to clay liners, with the result that the same classes are required for wood burning and solid fuel appliances and open fires. A1N1 and A1N2 concrete liners can only be used under dry conditions.

## Checking and Relining Existing Chimneys

It is important to check the condition of an old chimney, especially when re-opening one, after many years of not being used. A chimney should contain a sealed flue from the appliance to the chimney pot to transport the products of combustion safely to the atmosphere. Over time the condition of the flue can deteriorate. It was only from 1965 that Building Regulations required all new chimneys to be built with suitable flue liners of the correct flue size to protect the chimney.

The check should be carried out by a chimney specialist and would entail the following procedures:

- The chimney should be swept to ensure that it is clear of obstructions such as dislodged masonry or bird's nests
- A smoke test should then be carried out to establish whether there is any major fault that can cause products of combustion to leak through the chimney walls. A smoke test procedure is given later on in this guide.
- The structural stability should also be checked, as well as making sure the chimney is wind and water tight.

This should identify the repair work that is needed. Often the safest and most economical way to make the flue secure is to reline the chimney shaft with new liners. This can be done with clay, concrete or pumice liners, single wall stainless steel or flexible stainless steel liners.

To reline the chimney with clay, concrete or pumice liners, the liners are lowered down the chimney on guide ropes with locating bands at the joints. The gap between the liners and chimney is then backfilled with a lightweight insulating compound. The existing flue opening has to be made large enough for the liners to be installed. This benefit of this type of re-lining is its durability. However the cost can be prohibitive.

The alternative is to use stainless steel liners, either single wall rigid liners or flexible liners. Stainless steel flexible liners are designed to take on the shape of the chimney. The liners are installed by either lowering them down or pulling them up the chimney. They can go around most bends. Whilst their slim profile enables quick installation into chimneys where other systems might not fit, their life can be reduced if abnormally high corrosive soot or condensate deposits are created and allowed to accumulate in the flue or have not been thoroughly removed from the walls of the existing chimney flue.

## Fuel Burning

A chimney operates on the principle of having a natural up draught. One factor in creating the up draught is maintaining a warm flue gas temperature, of between 150°C and 450°C. Burning wood or multi fuel slowly with insufficient air supply, particularly on stoves or closed appliances must be avoided. Low flue gas temperatures will cause condensation and greatly increases the risk of producing excessive tar and corrosive soot deposits. This is a common problem, particularly when burning wet wood or coal and should be avoided. If soot and condensate deposits are allowed to accumulate in a flue, the deposits can ignite causing a chimney fire. These deposits can also be very corrosive and if they are not regularly removed can cause corrosion of the metal parts of both the chimney and the appliance.

When burning wood it is important to ensure that it is dry and well-seasoned. The HETAS Wood Fuel Guide provides useful information on the use of wood as a fuel. Always use suitable solid fuels. Some processed fuels can produce abnormally high temperatures together with very corrosive deposits. The HETAS Guide also contains a list of suitable fuels. An Approved Solid Fuel Merchant should also be able to give advice. Never burn household waste, plastics or chemicals, which can produce harmful fumes and corrosive vapours. These vapours can be dangerous to health and cause premature corrosion of metals. Where the appliance is slumbered overnight or for long periods it is advisable to run the appliance at high fire in a controlled manner for a period of at least 30 minutes. Slumbering is a contributing factor to premature liner failure through corrosion. It is important to ensure a sufficiently high flue gas temperature to minimise the products of combustion condensing out of the flue gases.

## Regular Inspection

The chimney should be swept regularly to remove soot and tar. At the very least the chimney should be swept at the start of the heating season. It is not recommended that the appliance is over fired, (allowed to burn fiercely and out of control), or chimney fires be started in an attempt to clean the chimney. Deposits of soot and tar will be greatly increased if unseasoned wood is burnt. Should a chimney fire occur, the chimney and appliance should be checked for damage before using them again.

It is also good practise to check at least every year or two the exposed parts of a chimney, flashings and terminals for signs of damage. Just like the outside of a house chimneys can suffer from the wear and tear of extreme weathering.

If at any time smoke or fumes are apparent or suspected from the appliance, chimney or flue, seek advice immediately from the installer or chimney expert in case there is a blockage or failure. Do not use the appliance or chimney until they have been thoroughly checked for safety and soundness. The escape of fumes can be dangerous.

## Chimney Cleaning

As a guide all flues should be swept before and during the heating season, and ideally at the end of the heating season to prevent tar and soot deposits having a corrosive effect on the chimney and appliance during the dormant period.

Mechanical sweeping with brush and rods is the only method of cleaning recommended because materials other than soot can block the flue e.g. mortar, brickwork, birds' nests. For this reason cleaning a flue using just chemical chimney cleaners or vacuum cleaning cannot be recommended as an alternative for correct chimney cleaning. (Some chemical cleaners can invalidate manufactures warranties).

Sweeping brushes should be made from suitable bristle and be of the same diameter or area as the flue being swept, and be fitted with a ball or free running wheel boss on the end to prevent scraping the flue walls, particularly at bends. Chimney manufacturers give instruction to which brush type to use on their systems. Use a qualified chimney sweep or member of NACS (National Association of Chimney Sweeps) who provide an inspection and sweeping certificate.



## Smoke Testing

If there is doubt about the condition of a chimney, or an old chimney is to be put in use after a long period of disuse, it is advisable to have it smoke tested. It is also recommended that a smoke test is carried out during the construction of masonry chimneys and on completion of all chimney installations. A smoke test should be carried out by a qualified person using the following procedure which is based on the test described in the European Standard BSEN 15287-1 for open fires and BSEN 15287-2 for room sealed appliances. There is a different procedure for smoke testing flues for gas fires. It must be remembered that the purpose of the smoke test is to identify any faults which would cause fumes to escape during the normal operation of the appliance and chimney. Closing the bottom and top of the chimney during the test, will generate a positive pressure in the flue. This will force the smoke, generated by the pellet, to escape through gaps in the joints in a masonry chimney, or connections between pre-fabricated metal chimneys and flue pipes.

Minor leakage detected during this test, would not be a major risk when the installation is used during normal operating conditions, providing the point of leakage does not indicate a fault that could get worse. However, if significant or heavy smoke leakage is seen, the cause must be investigated and rectified. Broken components, incorrect fitting and incomplete jointing of flue liners are the most common problems which cause major leakage and require remedial action.

### **The smoke test involves the following steps:**

1. If there is an appliance fitted at the base of the chimney, burn some newspaper in the grate for 2 to 3 minutes to establish a flue draw. A longer warming up time may be needed with wet or cold flues. If there is no grate or fire box fitted use a blow lamp for at least 10 minutes to establish a flue draw. This will assist the testing of the flue and not is intended to simulate real conditions.
2. Place at least two flue testing smoke pellets on a brick in the opening at the base of the flue or in the appliance if it is fitted. Follow the pellet manufacturer's safety instructions. The actual number of smoke pellets required will be determined by circumstances and the size of the pellets used. Generally, the larger the flue diameter the fewer pellets required. This is the result of the ratio of flue diameter compared to the surface area of the flue.
3. Ignite the pellets and when they start smoking cover the opening with a board or plate sealed at the edges or if an appliance is fitted, close all doors, ash pit cover and vents.
4. When smoke begins rising out of the top of the chimney, cap the top of the flue, terminal or pot using an inflated football bladder or plastic bag sealed in position with tape. A hole with a minimum diameter of 50mm must be left in the capping or sealing device.
5. Examine the full length of the chimney for any leakage of smoke. If possible check for signs of smoke leakage from wall cavities at the sides and back of the chimney, if it is built into a wall. Also check for smoke leakage at openings around windows near to the chimney and the roof space area.
6. If any smoke is seen establish the point of leakage and carry out remedial work to correct any faults.
7. After completing the remedial work repeat the testing procedure until no major leakage or fault is apparent. Remove the closures at the top and bottom of the chimney.

## Chimney, Flue and Appliance On-Site Identification

When a chimney or flue or a combustion appliance, (irrespective of fuel used), is installed or renovated, it is a mandatory requirement that a Check List and Notice Plate be completed. The purpose of the Check List is to ensure that the installation has been carried out correctly. The Notice Plate is a record of the installation, the appliance and fuels that can be used with the chimney. It must be located in a convenient and accessible location, for example, near a services meter. Completion of the data required on the Notice Plate can be by the heating appliance installer, builder, chimney supplier/installer or other competent person. This is an example of the Notice Plate as defined in Building Regulation Approved Document J.

### Checklist

**Hearths, fireplaces, flues and chimneys**

This checklist can help you to ensure hearths, fireplaces, flues and chimneys are satisfactory. If you have been directly engaged, copies should also be offered to the client and to the Building Control Body to show what you have done to comply with the requirements of Part J (Part F in N. Ireland). If you are a sub-contractor, a copy should be offered to the main contractor.

**1. Property address, where work has been carried out:**

---

**2. Location of hearth, fireplace, chimney or flue:**

**3. Fuel:**  Solid fuel  Wood  Gas  Oil  All

**4. Intended type of appliance:** State type or make. If open fire give finished fireplace opening dimensions

---

**5. Chimney or flue construction:**

**(a) State the type or make and whether new or existing**

**(b) Internal flue size:**  Circular Size  Square Size  Rectangular 228 x 90mm  Twin Wall Flue 125mm dia.

**(c) The flue liners/blocks have been laid with rebate uppermost.**  Yes

**(d) Details of fire outlet terminal and diagram reference:**  
Jointing material used \_\_\_\_\_  
Outlet terminal \_\_\_\_\_ Complies with outlet detail \_\_\_\_\_

**(e) Number and angle of bends:** \_\_\_\_\_

**(f) Provision for cleaning and recommended frequency:** \_\_\_\_\_

**6. Ventilation provisions for the appliance:** State type and areas of permanently open air vents  Existing  New

**7. Hearth form of construction**

**8. Inspection and testing after completion carried out by:** Tick if OK. Comment (if needed)

Tests (Appendix E in AD J 2002 Part F (N)) and result:

Visual inspection

Sweeping check

Smoke test

Appliance (where included) spillage  Water supply

**9. Location of notice plate:**  Electricity consumer unit  Other (please specify) \_\_\_\_\_

I/We the undersigned confirm that the above details are correct. In my/our opinion, these works comply with the requirements of Part J and Part F (N) of Schedule 1 to the Building Regulations.

Name (Block Capitals) \_\_\_\_\_ Profession \_\_\_\_\_  
Capacity \_\_\_\_\_ Telephone \_\_\_\_\_  
Address \_\_\_\_\_ Date \_\_\_\_\_  
Signature \_\_\_\_\_  
Registered membership of (e.g. CORGI, OFTEC, HETAS, NACSI)

### Important Safety Information

**This plate must not be removed or covered**

**1. Property address**

---

**2. The hearth and chimney located in the**

---

**3. Fuel suitable for**

Solid fuel  Wood  Gas  
 Oil  All

**4. Type of appliance**

---

**5.(a) Type of chimney liner**

Clay liners to BS EN 1457: 1999 1000 A3 N1 S D 3  
 Schedule 1 for all fuels  
 Schedule 2 with clay liners as above  
 Gas flue block to BS EN 1059: 2002 1250 120 D 1  
 Twin wall stainless steel flue BS EN 1056-1 1250  
 Other \_\_\_\_\_

**5.(b) Internal flue size**

Circular Size  
 Square Size  
 Rectangular 228 x 90mm  
 Twin Wall Flue 125mm dia.

**Suitable for condensing appliance**  Yes  No

**Installation date**

**Installed by**

**Other information**

Schedel Chimney Systems provide this plate but it is the installer's responsibility to ensure the details entered are correct, the correct type and size of flue has been used and the installation described fully complies with the Building Regulations in force at the time of installation.

---

## UK Building Regulations

England & Wales: The Building Regulations Approved Document J

Scotland: Building Regulations Technical Standards

Northern Ireland: Technical Booklet L Section 3 Building Regulations Northern Ireland

## European and British Standards which relate to Flues and Chimneys

All of the standards referenced below are either directly applicable to chimneys and flues, or contain relevant content and are correct at the time of publication of this document. Many of the standards cover the use for all fuels. Any Standards which are NOT pertinent to wood burning and multi fuel appliances have been italicised.

## Copies of European and British Standards can be obtained from:

British Standards Institution, 389 Chiswick High Road, Chiswick, London. W4 4AL. Tel: 0208 9969000

- BS EN 483:2000 Gas-fired central heating boilers. Type C boilers of nominal heat input not exceeding 70 kW. Replaced BS 5258: Pt 1; 1986
- BS EN 509:2000 Decorative fuel-effect gas appliances. Replaced BS 5258: Pt 12; 1990.
- BS 715: 2005 Specification for metal flue boxes for gas-fired appliances not exceeding 20kW.
- BS 1251: 1987 Specification for open fireplace components.
- BS EN 1443: 2003 Chimneys – general requirements
- BS EN 1457: 2012 Chimneys, Clay/Ceramic flue liners. Requirements and test methods. Replaced BS 1457: 1999
- BS EN 1806: 2006 Chimneys Clay/ceramic flue blocks for single wall chimneys. Requirements and test methods
- BS EN 1856 - 1: 2009 Chimneys. Requirements for metal chimneys. System chimney products. Replaced BS 4543: Pts 2 and 3 & BS 715: 1993
- BS EN 1856 - 2: 2009 Chimneys. Requirements for metal chimneys. Metal liners and connecting metal flue pipes Replaced BS 715: 1993
- BS EN 1857: 2010 Chimneys - Components. Concrete flue liners. Replaced BS 7435: Pts 1-2
- BS EN 1858 2008: Chimneys, Components, Concrete flue blocks. Replaced BS1289: Pt 1
- BS EN 1859 2009 Chimneys. Metal chimneys. Test methods. Replaced BS 4543: Pt 1:1990
- BS 5871: 2005 Specification for installation of gas fires, convector heaters, fire/back boilers and decorative fuel effect gas appliances
- Pt1: Gas fires, convector heaters and fire/back boilers.
- Pt2: Inset live fuel effect gas fires of heat input not exceeding 15kW.
- Pt3: Decorative fuel effect gas appliances of heat input not exceeding 15kW.
- BS 5440: 2008 Installation of flues and ventilation for gas appliances of rated input not exceeding 70 kW.
- Pt1: 2008 Specification for installation of flues.
- Pt2: 2008 Specification for installation of ventilation for gas appliances.
- BS 15287-1 Open Appliances, BS15287-2 Room-Sealed Appliances Installation of chimneys and flues for domestic appliances burning solid fuel (including wood and peat). Code of practice for masonry chimneys and flue pipes
- BS 6999:1989 Specification for vitreous-enamelled low carbon steel flue pipes
- BS 7977-1:2009 Specification for safety and rational use of energy of domestic gas appliances. Radiant/convectors Replaced BS 5258: Pts 5 and 16
- BS 7977-2:2009 Specification for safety and rational use of energy of domestic gas appliances. Combined appliances. Gas fire/back boiler. Replaced BS 5258: Part 8
- BS EN 15287-1: 2007 Chimneys. Design, installation and commissioning of chimneys. Chimneys for non-room-sealed appliances.
- BS EN 12446 : 2011 Chimneys. Components. Concrete outer wall elements
- BS EN 13063-1: 2005 Chimneys. System chimneys with clay/ceramic flue liners. Requirements and test methods for sootfire resistance
- BS EN 13063-2: 2005 Chimneys. System chimneys with clay/ceramic flue liners. Requirements and test methods under wet conditions
- BS EN 13069: 2005 Chimneys. Clay/ceramic outer walls for system chimneys. Requirements and test methods
- BS EN 13216 : 2004 Chimneys. Test methods for system chimneys. Replaced BS 4543
- BS EN 13502 : 2002 Chimneys. Requirements and test methods for clay/ceramic flue terminals. Replaced BS 1181:1999.
- BS EN 50291-1: 2010. Electrical apparatus for the detection of carbon monoxide in domestic premises. Test methods and performance requirements.

## Useful Contacts

---



### HETAS

Orchard Business Centre, Stoke Orchard,  
Gloucestershire. GL52 7RZ  
Tel: 0845 634 5626  
Email: [info@hetas.co.uk](mailto:info@hetas.co.uk)  
[www.hetas.co.uk](http://www.hetas.co.uk)

HETAS maintains a register of suitably trained installers. It also produces an annual Guide for Approved Solid Fuel Products and Services, which includes A comprehensive list of chimney and flue systems available from members of the BFCMA.



### NACS

National Association of Chimney Sweeps  
Tel: 01785 811732  
Email: [nacs@chimneyworks.co.uk](mailto:nacs@chimneyworks.co.uk)  
[www.nacs.org.uk](http://www.nacs.org.uk)

NACS provide a list of their members throughout the UK.



### SIA

Stove Industry Alliance  
Haseley Manor, Birmingham Road, Warwick, Warwickshire, CV35 7LS  
Tel: 01789 415640  
Email: [info@sia.gb.com](mailto:info@sia.gb.com)  
[www.stoveindustryalliance.com](http://www.stoveindustryalliance.com)

The SIA is an alliance of manufacturers, distributors, advisory/test house bodies and other interested parties who sell stoves, both space heaters and boiler stoves, and also flue and chimney products and fuel.



### SFA

Solid Fuel Association  
7 Swanwick Court, Alferton, Derbyshire, DE55 7AS.  
Tel: 01789 415640  
Email [sfa@solidfuel.co.uk](mailto:sfa@solidfuel.co.uk)  
[www.solidfuel.co.uk](http://www.solidfuel.co.uk)

## Some Do's and Dont's

---

**Do** ensure that when an appliance is fitted to an existing chimney system it is inspected and tested for soundness and any defects are rectified.

**Do** ensure that chimney or flue system is always installed and supported and that all joints are properly, securely and efficiently made strictly in accordance with the manufacturer's instructions.

**Do** ensure that the flue pipe connection from the appliance rises vertically for at least 600 mm before any change of direction is contemplated. The reason for this is that the flue draught is crucial nearer the appliance because of the higher flue gas temperature. Any horizontal or angled runs at the bottom of the flue will create severe restriction to flue gas movement and affect appliance operation.

**Do** try to construct the chimney vertically all the way to the terminal. Where bends are necessary, do not use more than 4 bends. Generally the maximum bend is 45° from the vertical with the exception of 90° factory made bends or tees which may be treated as being equal to two 45° bends.

**Do** ensure that the flue diameter is not less than the diameter of the appliance outlet.

**Do** ensure that the effective height of any chimney with bends (vertical distance between appliance and terminal) is at least twice the horizontal distance between the appliance and terminal.

**Do** try to position the chimney inside the building to avoid excessive cooling and risk of condensation.

**Do** ensure that the chimney is installed and located in accordance with Building Regulations and British Standards, particularly where distinct distances from combustible materials are required.

**Do** ensure that the chimney is thoroughly inspected, and that smoke tests are carried out before the appliance is used.

**Do** remember a permanent supply of combustion air must be provided and kept clear from obstruction.

**Do** remember that a heating appliance needs to be checked regularly and the flues expertly swept.

**Do** ensure that the installation is carried out by a HETAS registered installer.

**Do** ensure an approved Carbon Monoxide Alarm is installed on every installation.

**Do** ensure the Notice / Data Plate is correctly completed and positioned.

**Don't** use any single wall flue system as a chimney.

**Don't** allow clothes, furnishings or any combustible materials to come into contact with the surface of any flue pipe or prefabricated metal chimney.

**Don't** use bends if they can be avoided.

**Don't** run horizontal flue anywhere in the system other than a maximum 150mm horizontal length into the chimney from a back outlet appliance.

**Don't** position the chimney externally if it can be avoided.

**Don't** be tempted to use non BS EN certificated flue and chimney systems; they may only last for a short time and will have to be replaced by the correct product. It will then be at least twice as expensive in the long run. Use of non-approved products is also illegal.



# BFCMA

BRITISH FLUE & CHIMNEY  
MANUFACTURERS  
ASSOCIATION

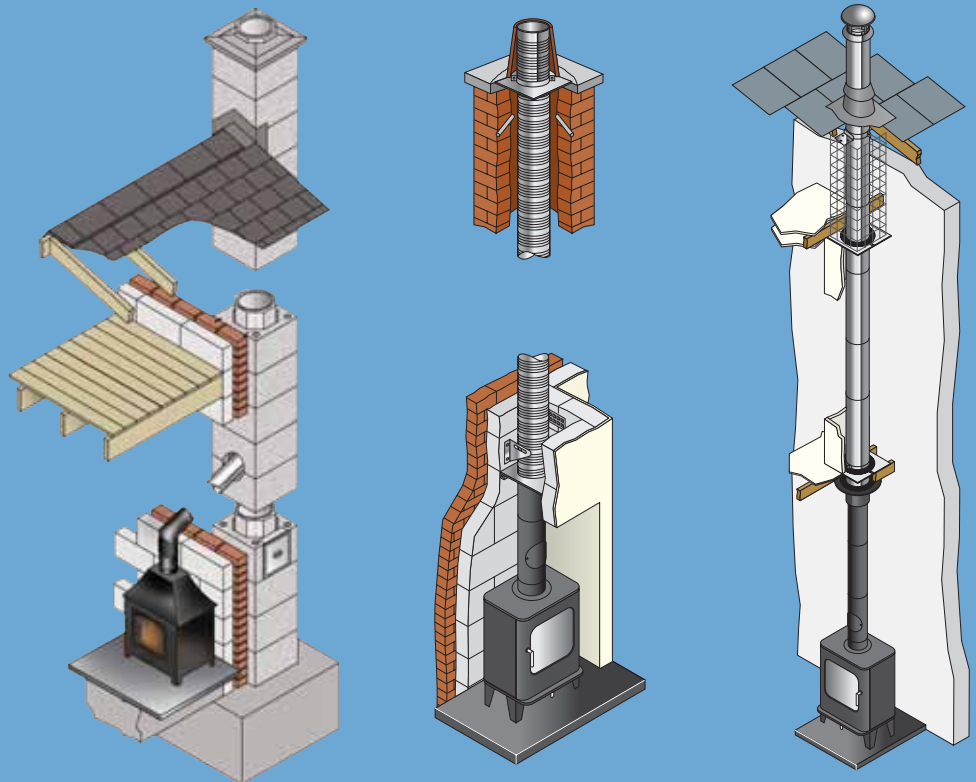

# Installation Guidelines

for Wood Burning &  
Multi Fuel Appliances



# Wood Burning & Multi Fuel Stoves

## Connecting Flue Pipe

The stove should be connected to the flue using vitreous enamel or 1mm thick single wall stainless steel pipe.

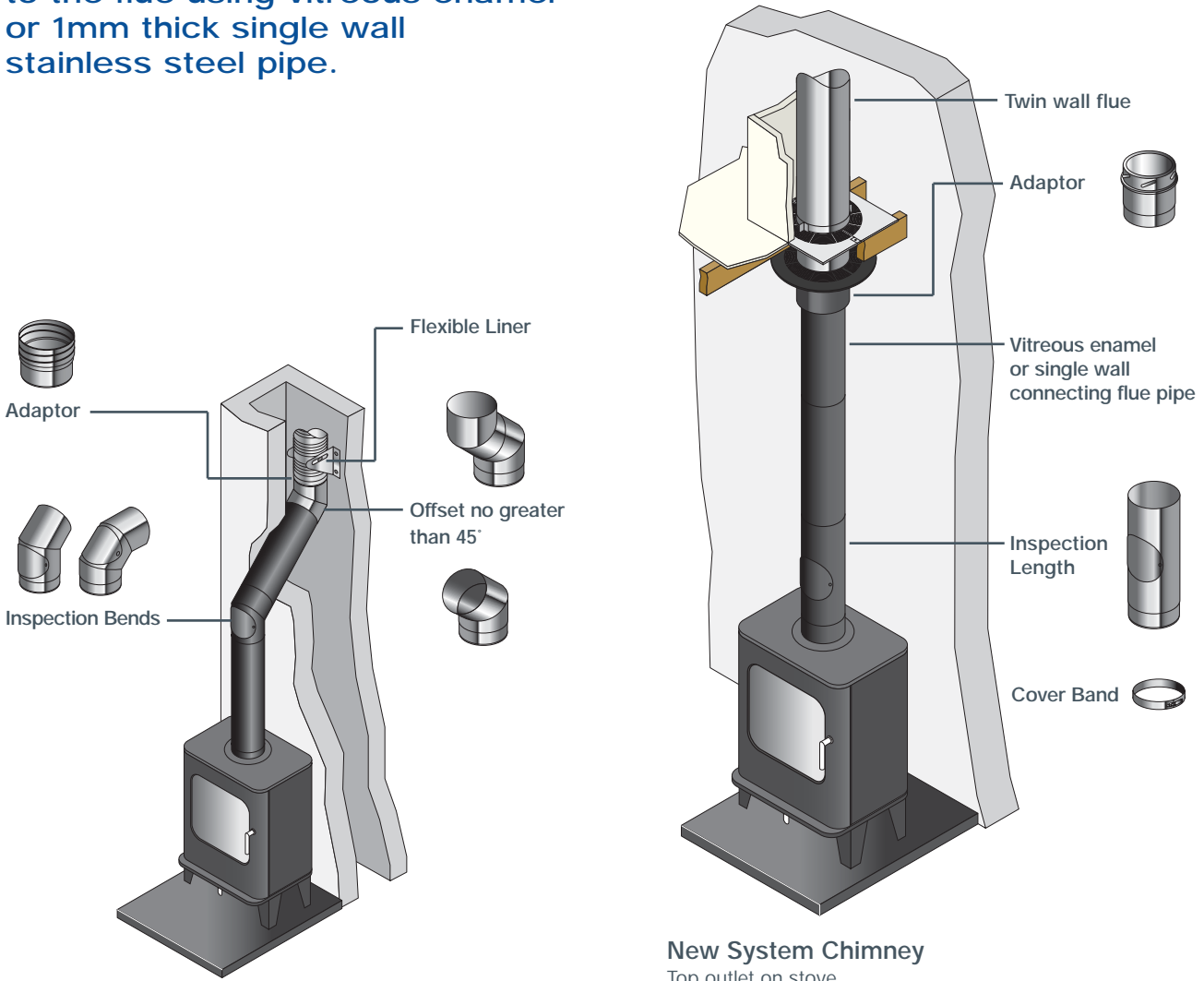

**Existing Masonry Chimney**  
Top outlet on stove

**New System Chimney**  
Top outlet on stove

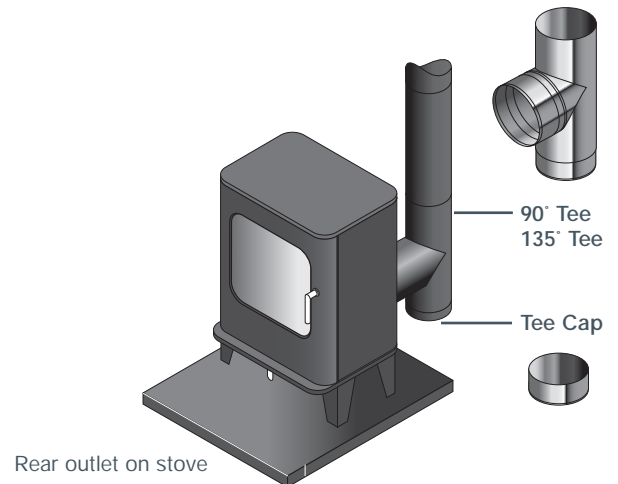

Rear outlet on stove

Installations shown are by way of illustration only. Manufacturer's installation instructions should always be consulted before installation.

# Wood Burning & Multi Fuel Stoves

## Existing Chimneys

### Relining an existing chimney with twin wall flexible liner

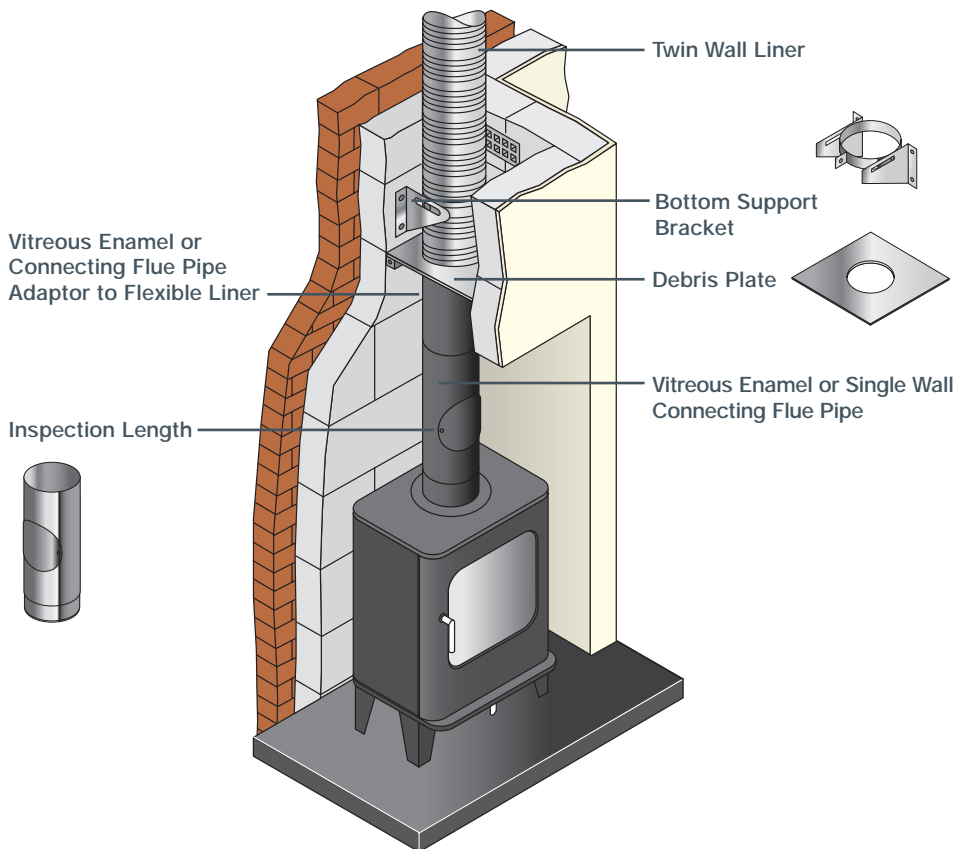
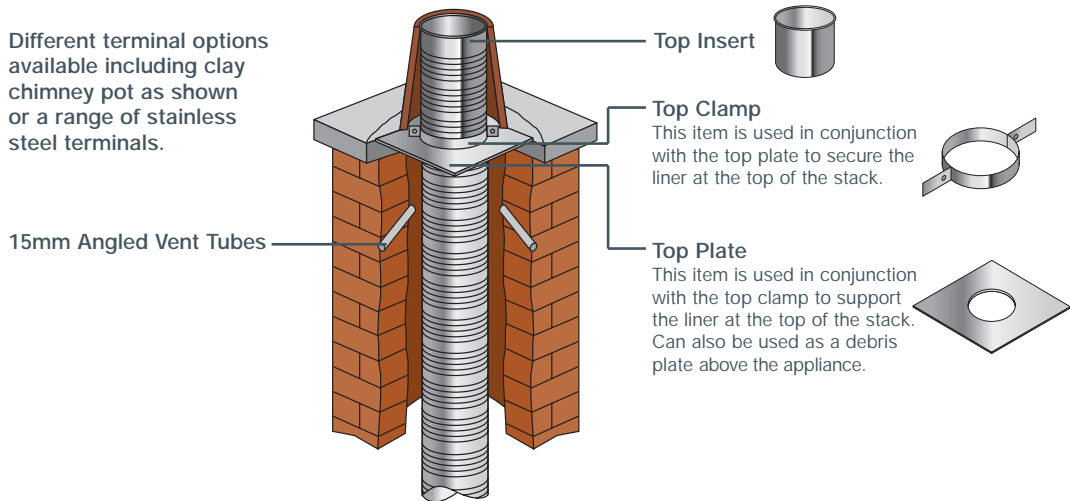

# Wood Burning & Multi Fuel Stoves

## Existing Chimneys

### Relining an existing chimney with single wall liner.

If the 0.6mm thick liner has been tested in accordance with BSEN1856 part 2 then it may be used. If not then 1mm single wall liner must be used.

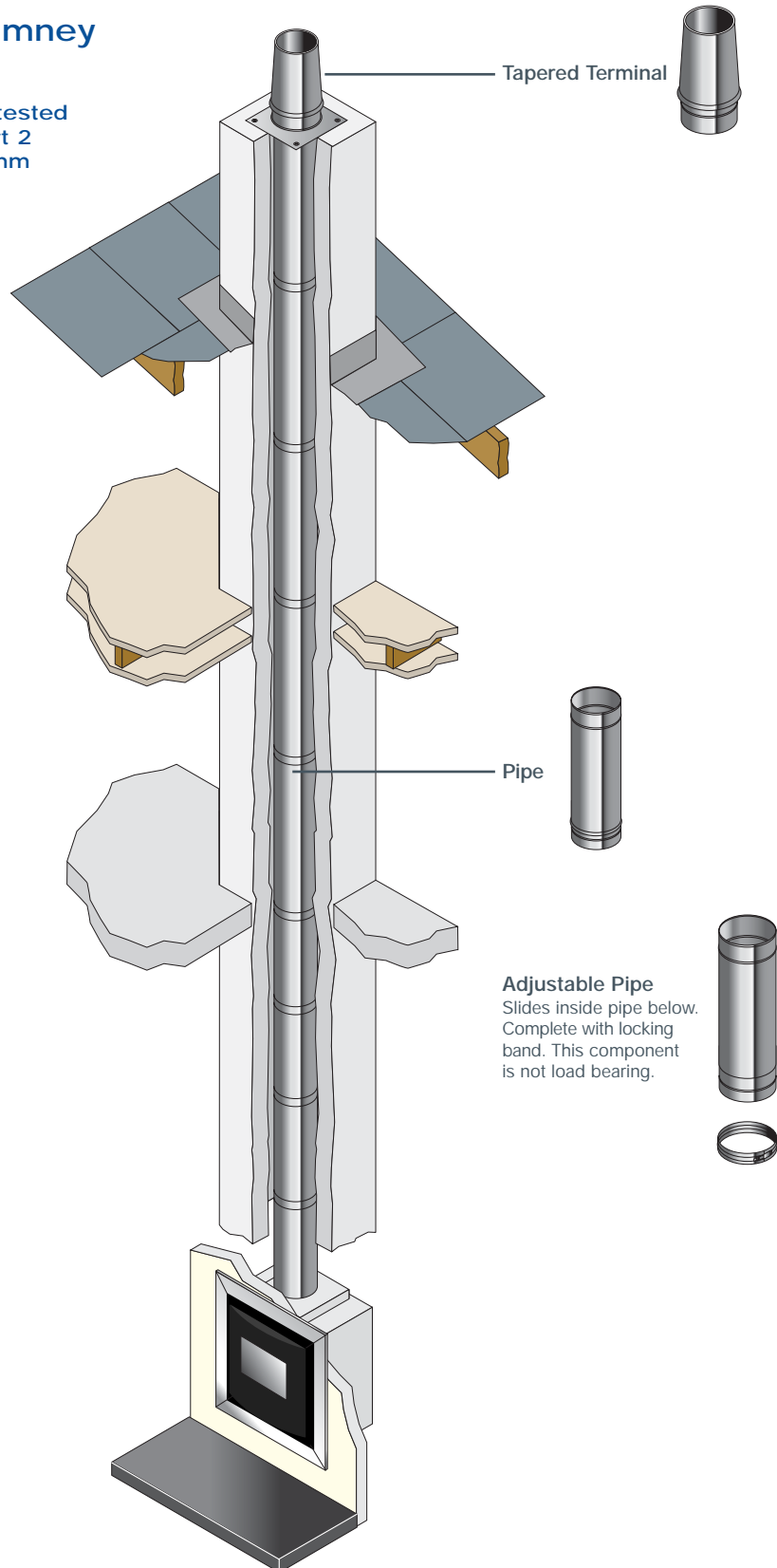

Installations show are by way of illustration only. Manufacturer's installation instructions should always be consulted before installation.

# Wood Burning & Multi Fuel Stoves

## New Chimneys

### - Stainless Steel Twin Wall Flue

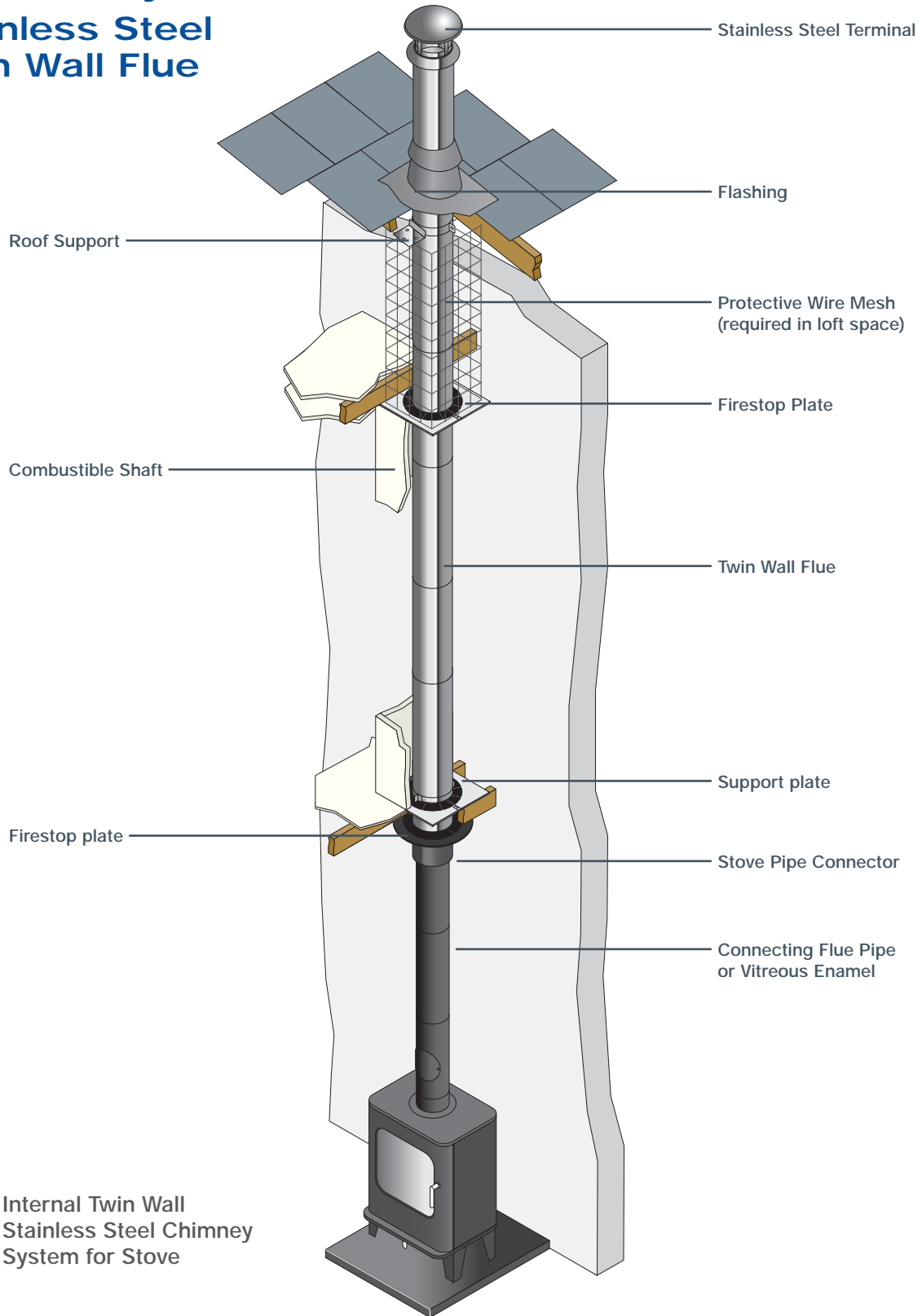

Installations show are by way of illustration only. Manufacturer's installation instructions should always be consulted before installation.

# Wood Burning & Multi Fuel Stoves

## Clay Concrete & Pumice - Chimney Systems

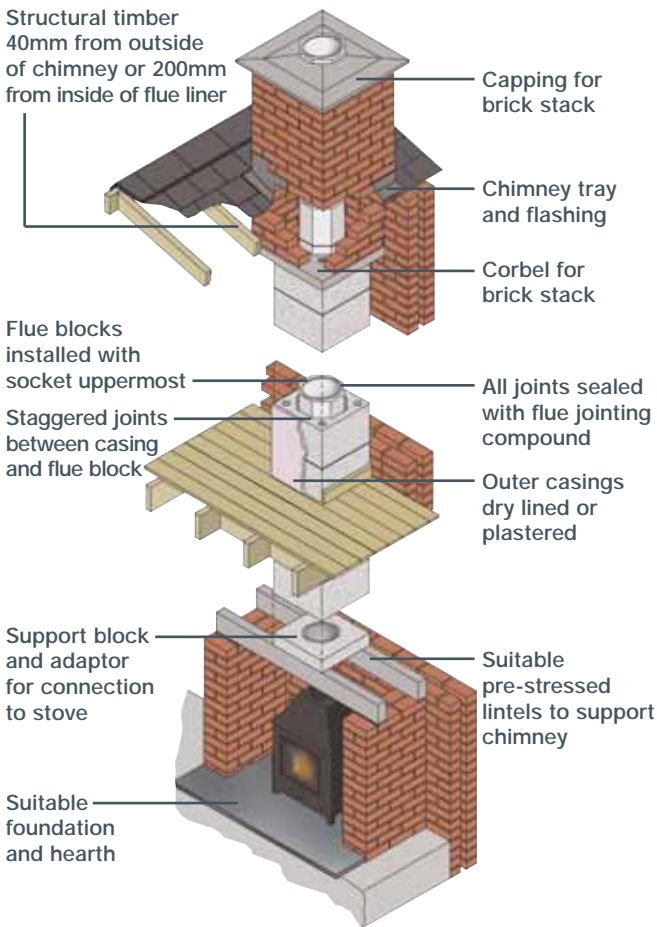

Free Standing Stove in an Alcove

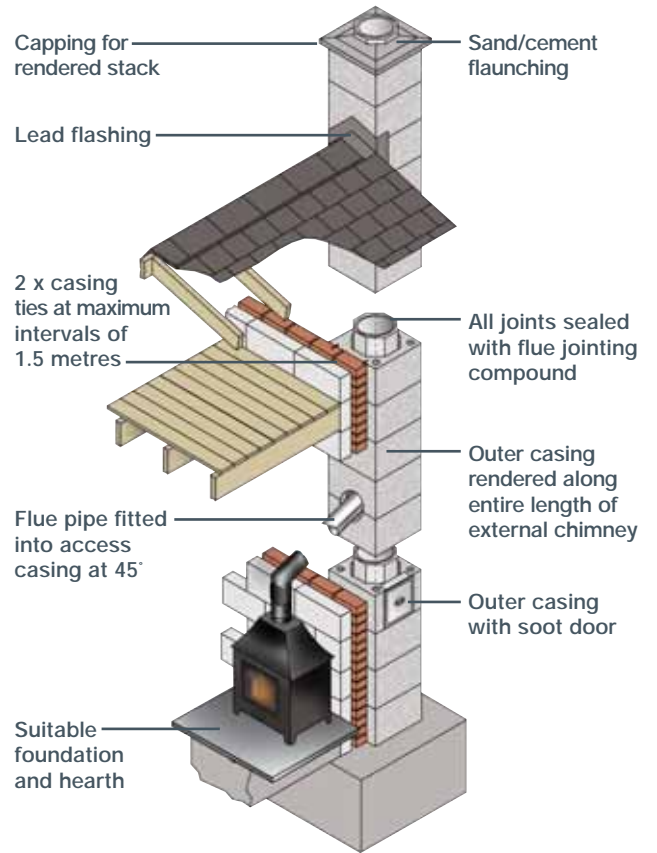

Free standing stove with external chimney with preformed stove entry kit

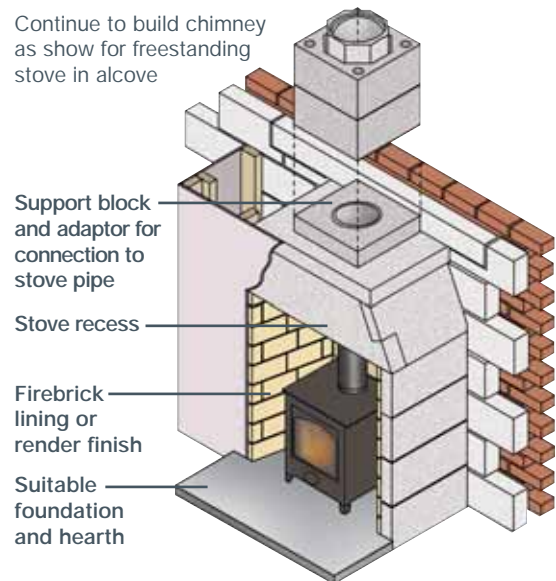

Stove Recess

Installations show are by way of illustration only. Manufacturer's installation instructions should always be consulted before installation.

# Wood Burning & Multi Fuel Stoves

## Clay Concrete & Pumice - Chimney Systems

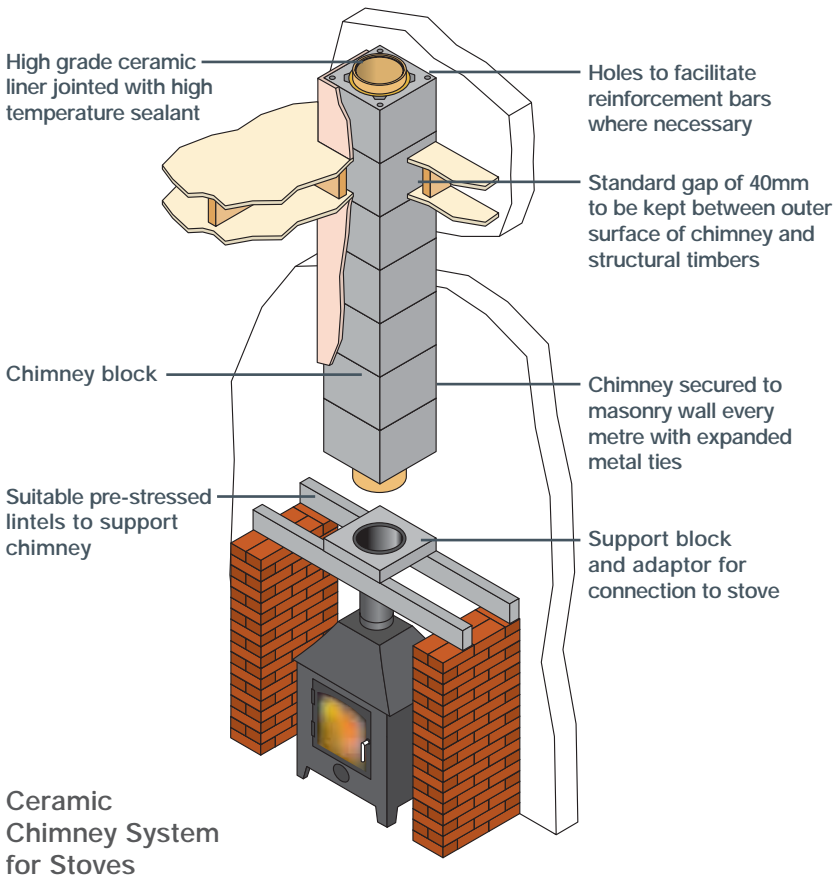
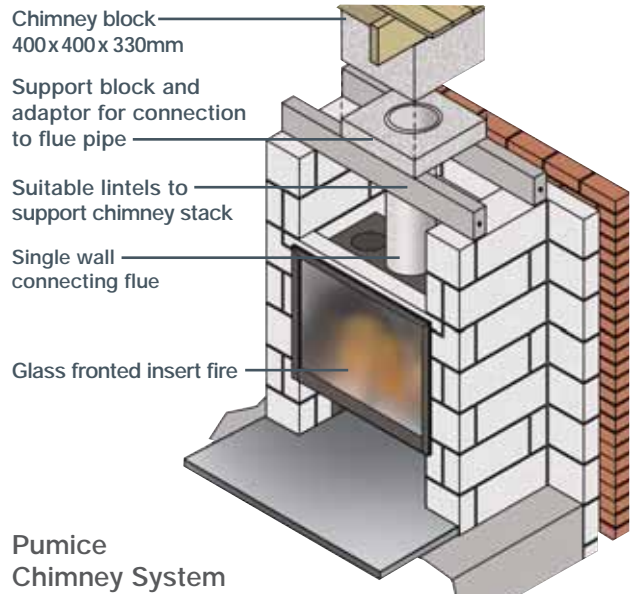
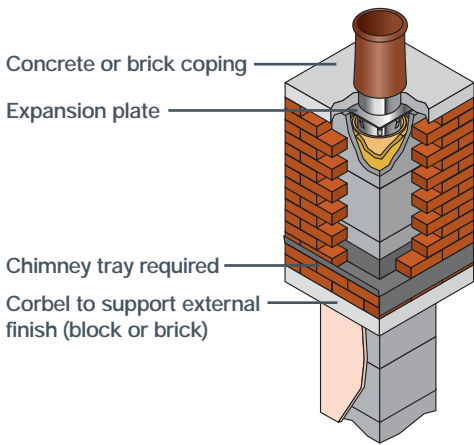

Installations show are by way of illustration only. Manufacturer's installation instructions should always be consulted before installation.



# Wood Burning & Multi Fuel Stoves

## Clay Concrete & Pumice - Liners

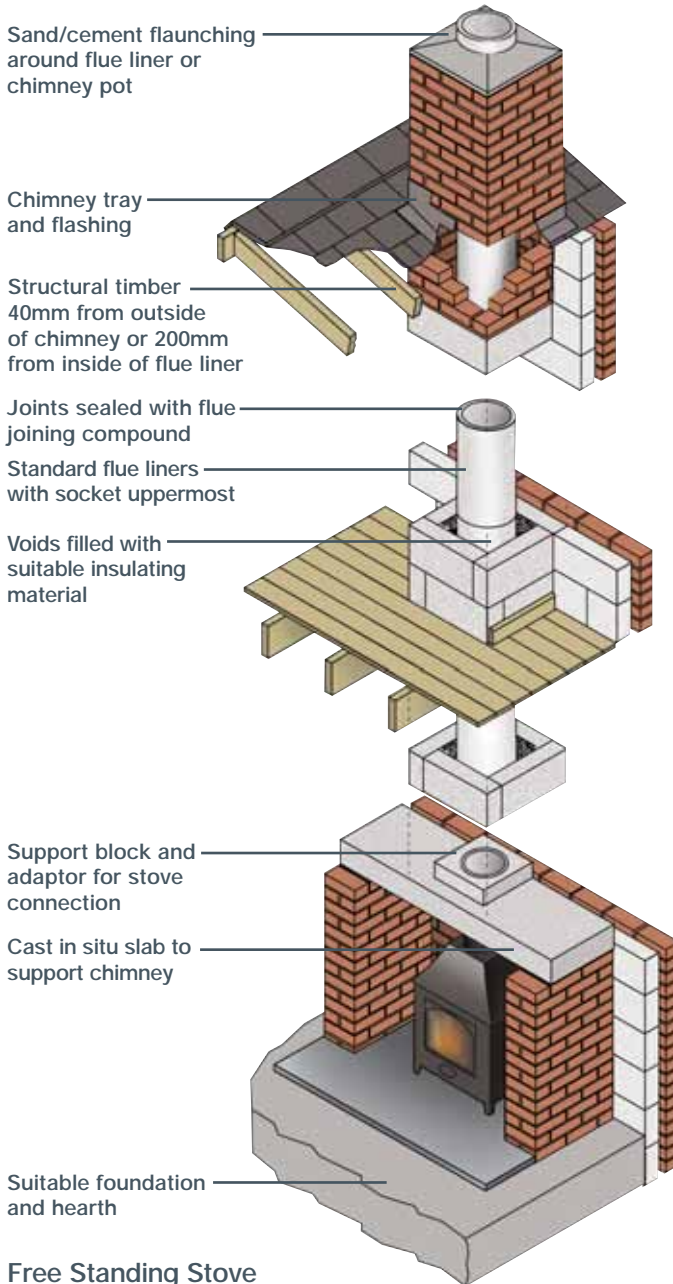

Continue to build chimney as in free standing stove

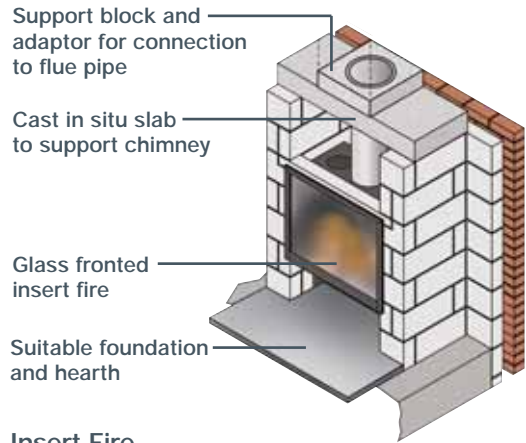

Insert Fire

# Open Fires

## Clay Concrete & Pumice - Chimney Systems

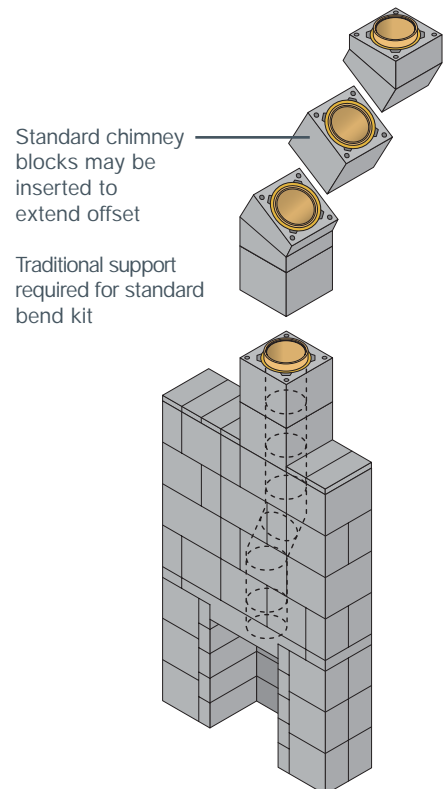
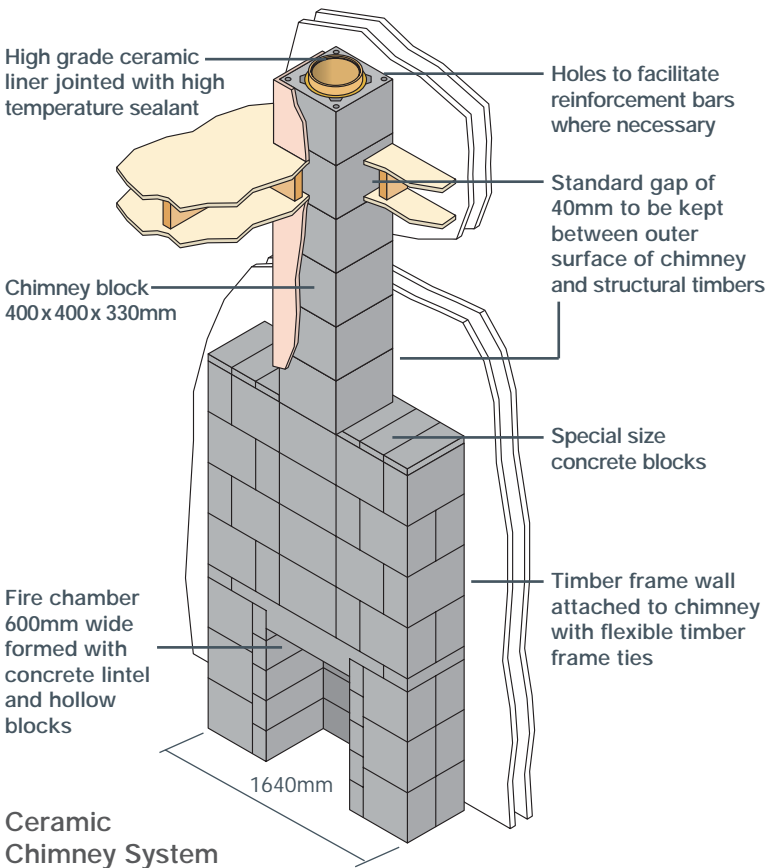
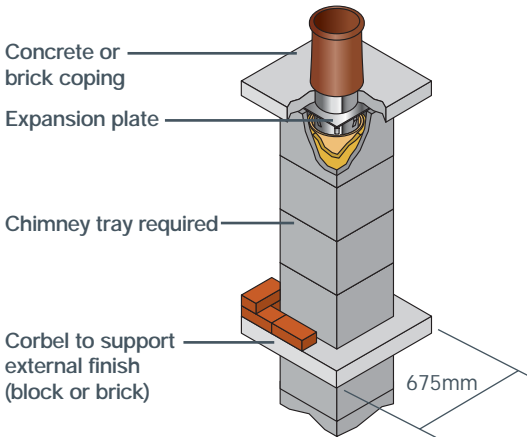

### Chimney Breast Bend Kit

Two Bend Kits are available. The Breast Bend Kit allows the flue to be removed from 200 - 400mm within the chimney breast. The Standard Bend Kit allows the flue to be moved horizontally as desired so long as it is supported in the traditional manner.

# Open Fires

## Clay Concrete & Pumice - Chimney Systems

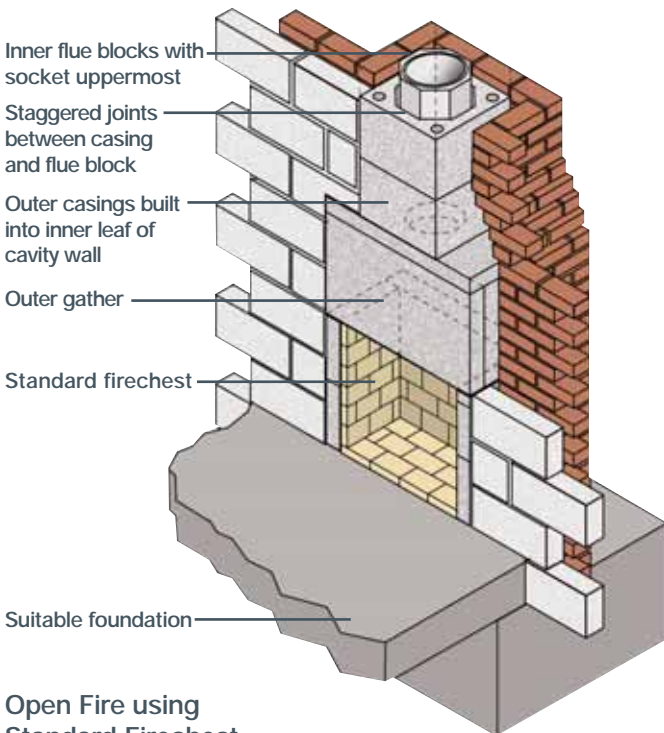
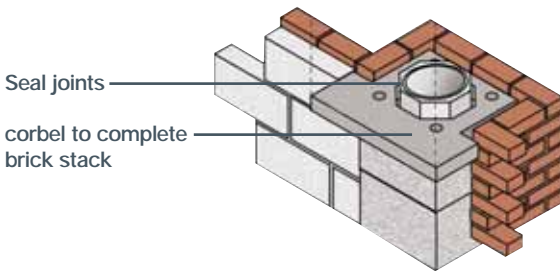
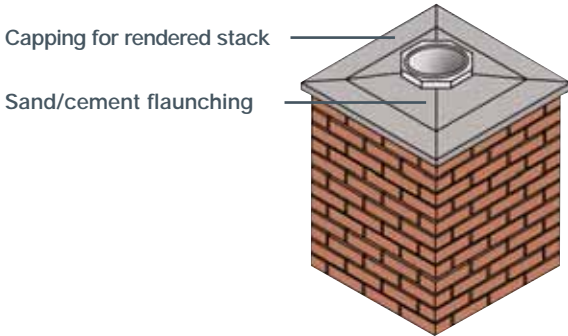

Open Fire using  
Standard Firechrest

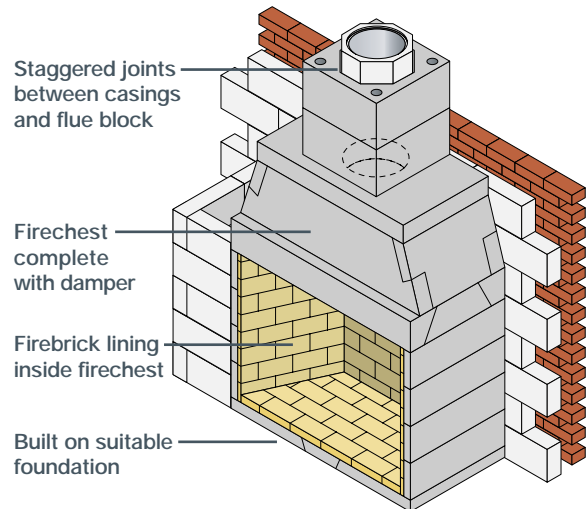

Firechrest

# Open Fires

## Clay Concrete & Pumice - Liners

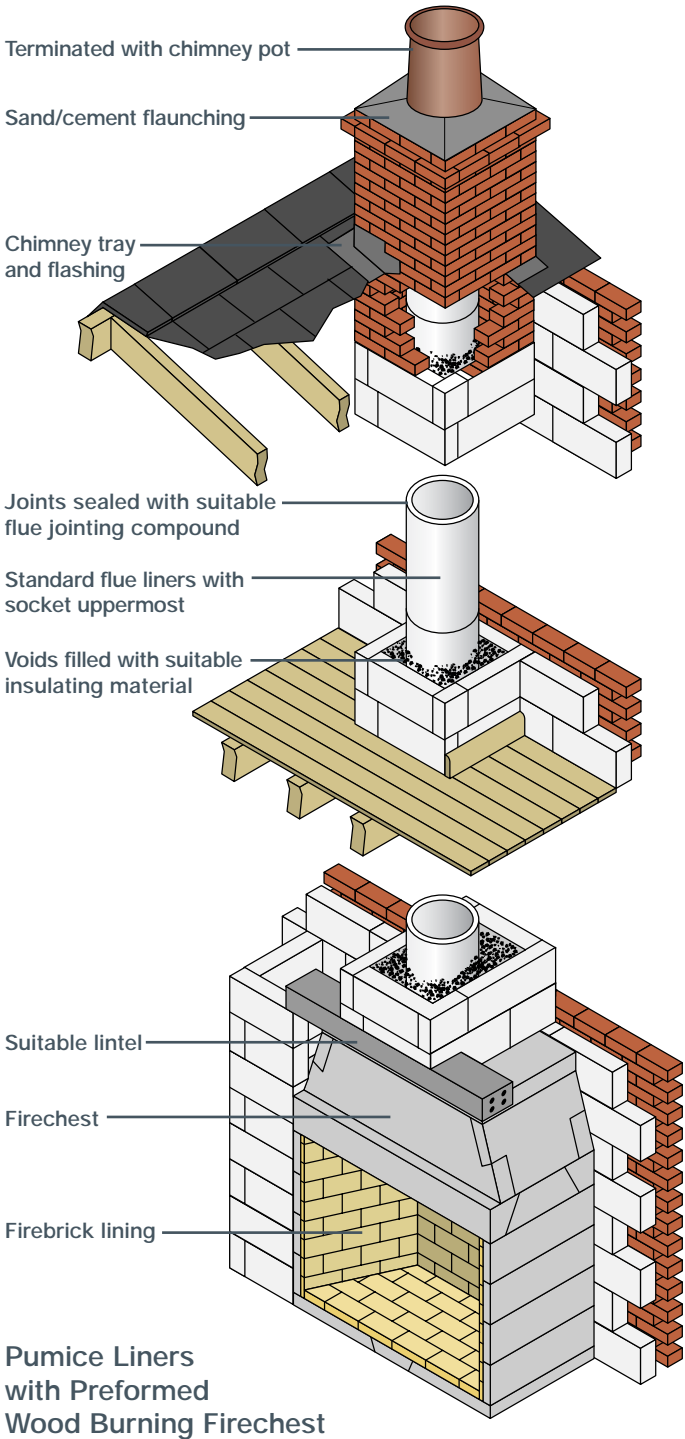

**Pumice Liners  
with Preformed  
Wood Burning Firechest**

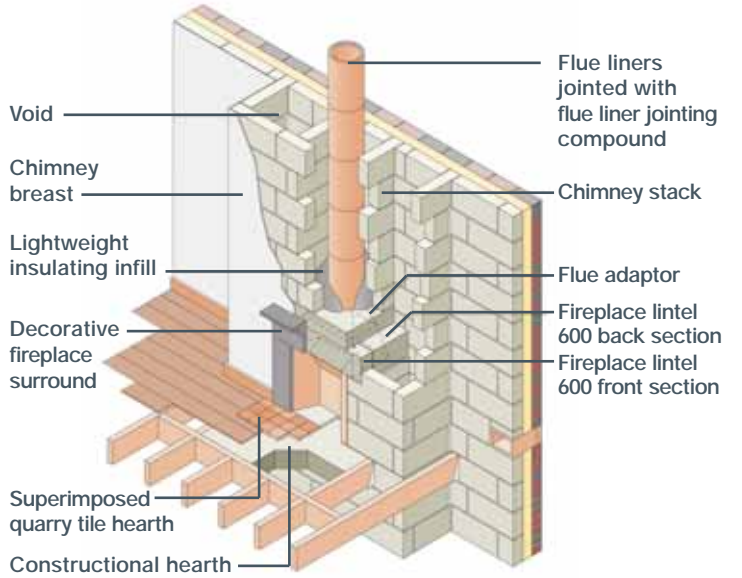

**Standard Methodology for  
Clay, Concrete & Pumice Liners**

Installations shown are by way of illustration only. Manufacturer's installation instructions should always be consulted before installation.

# Wood Burning & Multi Fuel Appliances

## Chimney Fan System

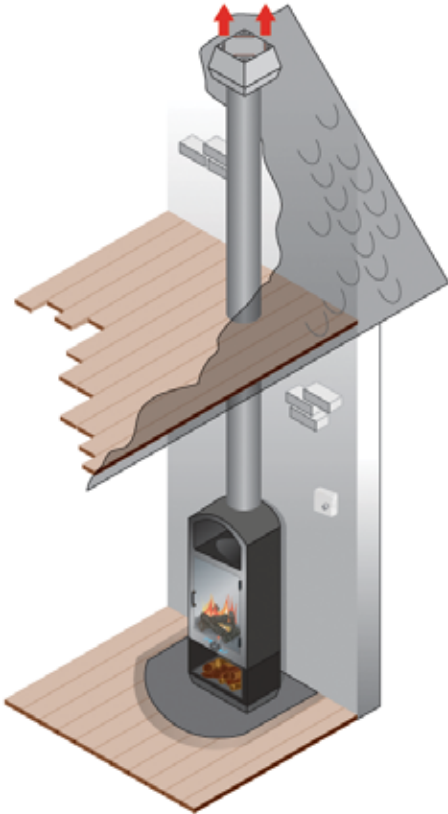

Installations shown are by way of illustration only. Manufacturer's installation instructions should always be consulted before installation.



## Examples of Terminals

### Examples of Stainless Steel Terminals, Birdguards & Anti-Downdraught Terminals

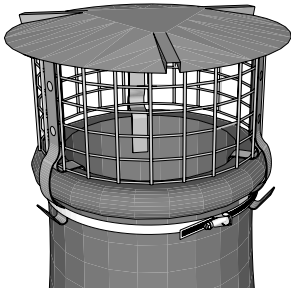

Birdguard  
fitted to Chimney Pot



Raincap  
fitted to Chimney Pot

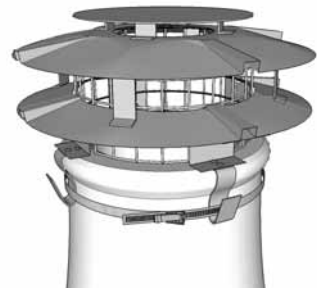

Solid Fuel Anti-Downdraught  
fitted to Chimney Pot  
(with or without mesh)

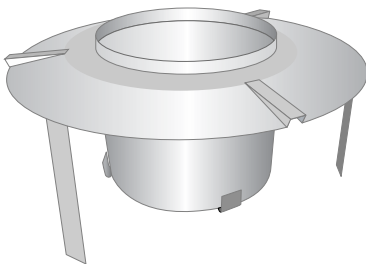

Pot Hanger  
fitted to Twin Wall Flexible Liner

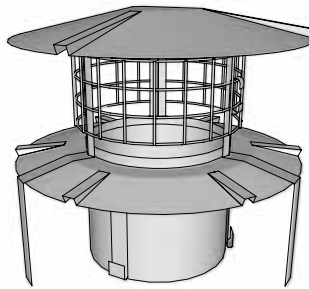

Birdguard Pot Hanger  
fitted to Twin Wall Flexible Liner  
(with or without mesh)

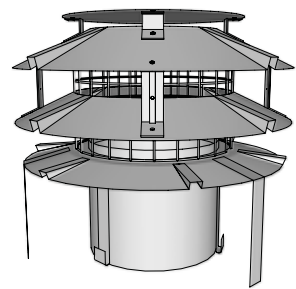

Anti-Downdraught Pot Hanger  
fitted to Twin Wall Flexible Liner  
(with or without mesh)

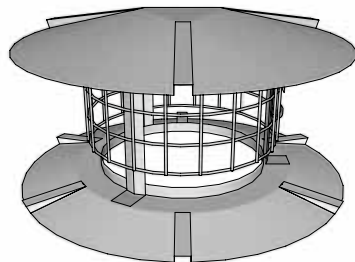

Birdguard  
fitted to Twin Wall System  
(with or without mesh)

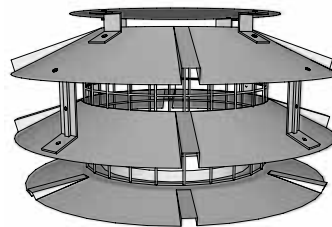

Anti-Downdraught  
fitted to Twin Wall System  
(with or without mesh)



## List of Members

### **Brewer Metalcraft**

Units C & D,  
Ford Lane Industrial Estate,  
Ford, Arundel,  
West Sussex,  
BN18 0DF,  
T: 0745 676 0702  
F: 0845 676 0703  
E: sales@brewercowls.co.uk  
www.brewercowls.co.uk

### **Deks UK**

West End Trading Estate,  
Blackfriars Road,  
Nailsea, Bristol,  
BS48 4DJ,  
T: 01275 858 866  
F: 01275 855 887  
E: sales@deks.co.uk  
www.deks.co.uk

### **Exodraft**

Unit 3 Lancaster Court Coronation Road,  
Cressex Business Park,  
High Wycombe,  
Buckinghamshire,  
HP12 3TD,  
T: 01494 465166  
F: 01494 465163  
E: info@exodraft.co.uk  
www.exodraft.co.uk

### **H. Docherty**

15/16 Colthrop Business Park,  
Thatcham,  
Berkshire,  
RG19 4NB,  
T: 01635 292 400  
F: 01635 201 737  
E: sales@docherty.co.uk  
www.docherty.co.uk

### **Hanson Red Bank**

Atherstone Road,  
Measham,  
Swadlincote,  
Derbyshire,  
DE12 7EL,  
T: 01530 270333  
F: 01530 273667  
E: sales@redbankmfg.co.uk  
www.redbankmfg.co.uk

### **JRF Chimney Specialists & Heating Distributors**

50 Nasmyth Road,  
Southfield Industrial Estate,  
Glenrothes, Fife,  
KY6 2SD,  
T: 01592 771199  
F: 01592 771135  
E: info@jrf-chimney-spec.co.uk  
www.jrf-chimney-spec.co.uk

### **Mi-Flues**

Spiro House, Cocker Avenue,  
Poulton Business Park,  
Poulton-Le-Fylde,  
Lancashire,  
FY6 8JU,  
T: 01253 884 972  
F: 01253 893 752  
E: sales@mi-flues.com  
www.mi-flues.com

### **MMF**

Flue House,  
55 Woodburn Road,  
Smethwick,  
West Midlands,  
B66 2PU,  
T: 0121 555 6555  
F: 0121 555 1606  
E: mmf@fluepipes.com  
www.fluepipes.com

### **Muelink & Grol B.V.**

Postbus 509,  
9700 AM Groningen - Holland,  
Duinkeerkestraat 27,  
9723 BP Groningen - Holland,  
T: +31 (0) 50 313 9944  
F: +31 (0) 50 318 5423  
E: sales@muelink-grol.com  
www.muelink-grol.com

### **Pennine Systems**

Crossley Works, Stockfield Mount,  
Off Peel Street, Chadderton,  
Oldham,  
Lancashire,  
OL9 9LR,  
T: 0161 678 2998  
F: 0161 678 2997  
E: sales@penninesystems.co.uk  
www.penninesystems.co.uk

### **Poujoulat (UK)**

Unit 1, Quadrum Park,  
Old Portsmouth Road,  
Guildford,  
Surrey,  
GU3 1LU,  
T: 01483 461700  
F: 01483 533435  
E: sales@poujoulat.co.uk  
www.poujoulat.co.uk

### **W.T. Knowles & Sons**

Ash Grove Pipe Works,  
Elland,  
West Yorkshire,  
HX5 9JA,  
T: 01422 372 833  
F: 01422 370 900  
E: sales@wtknowles.co.uk  
www.wtknowles.co.uk

### **Schiedel Chimney Systems**

Crowther Estate, Washington,  
Tyne & Wear,  
NE38 0AQ  
*Schiedel Rite-Vent*  
T: 0191 4161150  
F: 0191 415 1263  
*Schiedel Isokern*  
T: 01202 861650  
F: 01202 861632  
E: info@schiedel.co.uk  
W: www.schiedel.co.uk

### **SFL Flues & Chimneys**

Pottington Business Park,  
Barnstaple,  
Devon,  
EX31 1LZ,  
T: 01271 326633  
F: 01271 334303  
E: info@sflchimneys.com  
www.sflchimneys.com

### **Simplefit**

Central Crescent,  
Marchwood Industrial Park,  
Marchwood,  
Southampton,  
SO40 4BJ,  
T: 023 8066 3210  
F: 023 8066 3086  
E: sales@simplefit.co.uk  
www.simplefit.co.uk

### **Specflue**

8 Curzon Road,  
Chilton Industrial Estate,  
Sudbury,  
Suffolk,  
CO10 2XW,  
T: 01787 880333  
F: 01787 880555  
E: sales@specflue.com  
www.specflue.com

### **Wavin**

Hazlehead,  
Crow Edge,  
Sheffield,  
South Yorkshire,  
S36 4HG,  
T: 0844 856 5152  
F: 0870 443 8000  
E: customerservices@wavin.co.uk  
www.hepworthterracotta.co.uk