

# FloorCare

PRODUCT RANGE  
CATALOGUE



The development of floors and flooring materials within the broad range of commercial developments has been very pronounced over the past decade.

Not only have floors become more exotic in both design and material selection but, equally, we all expect to see the floor maintained to an exceptionally high standard, literally sparkling cleaning, in high profile locations; super clean in the workplace and public space... just as we would expect in our own living space.

## Contents

Hurricane	4-7	TwinTec Vario	22-25
Nuspeed	8-9	Ride-on	26-31
TwinTec Mains / Cable	10-14	Brushes and Pads	32-33
TwinTec Battery	15-21	Accessories	34-35



The Right Equipment For The Right Job Will Provide The Right Results.

# Hurricane *The 1000W Size*

The single disc floor machine is the heart of all hard floor cleaning and maintenance.

The Hurricane motor concept is designed to keep its "Cool" under continuous and arduous operation whilst its seamless power transmission to the floor is via our long-life, oil filled, low load planetary gearbox. THE HFM1015 150rpm machine is equipped with the 1000W Hurricane motor providing a lighter weight and economical solution.

- **Planetary Gearbox**  
Long life, oil filled, low load planetary gearbox.
- **Hi-Cool Motor**  
Heavy duty, long life motor.
- **ATC (Automatic Torque Control)**  
Monitoring and balancing power input throughout the cleaning cycle.
- **Fully Adjustable Handle**  
For the perfect working position.

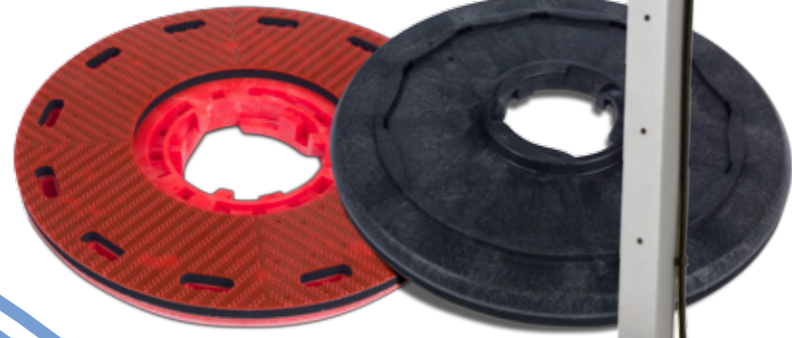

NuLoc 2 Pad Drive System option



Large solution tank option

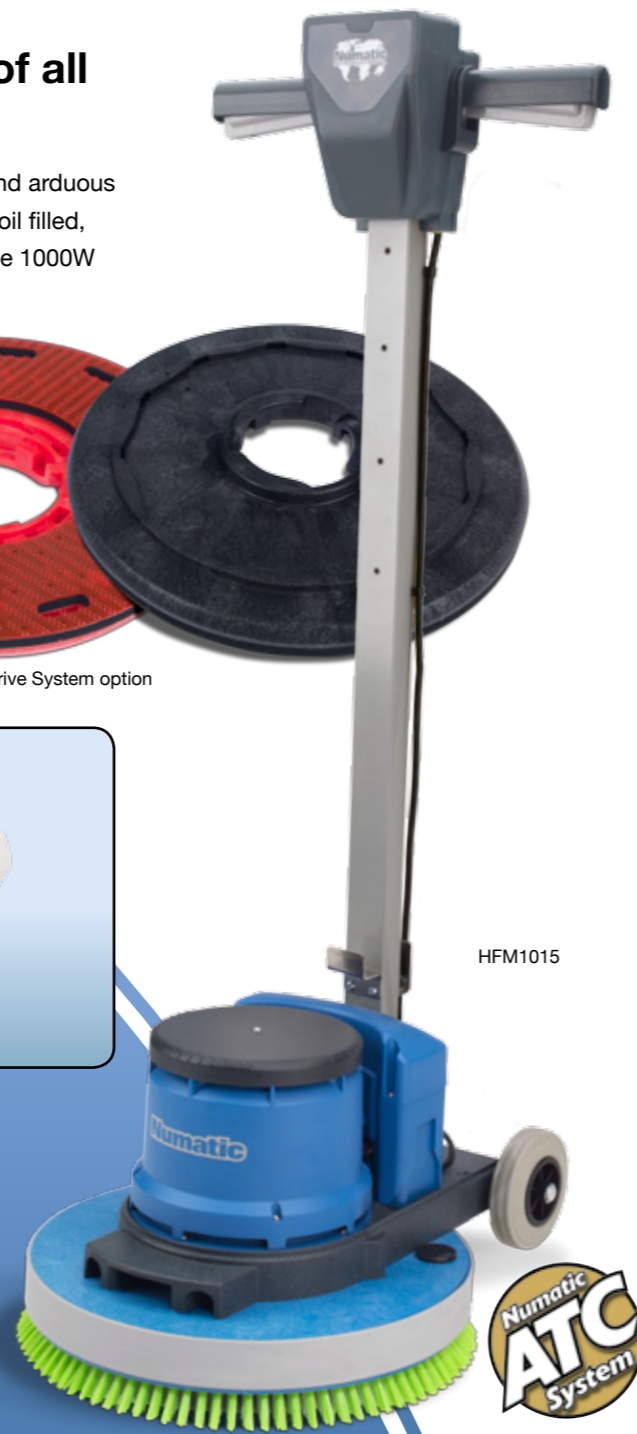

HFM1015



All Hurricane models incorporate our ATC, Automatic Torque Control, monitoring and balancing operational power input throughout the cleaning cycle.



Optional Hi-Dust Motor Filter



Planetary gearbox



Simple operator control

Model	Motor	Deck	Brush	Pad	Power	Speed	Range	Weight	Dimensions (WxLxH)
HFM 1015	1000W	450mm	450mm	400mm	230V AC 50Hz	150rpm	32m	26kg	460x560x1250mm

# Hurricane *The 1500W Size*

The HFM 1500 series is available in a choice of 4 different speeds, 150rpm, 230rpm, 300rpm and extra Hi-speed 450rpm.

All models are fitted as standard with our generous oversize Hurricane 1500W drive motor allowing for higher speeds and the use of added weight as required.

The long life, low load, oil filled planetary gearbox ensures seamless power transmission to the floor ensuring excellent results.

With the range of speeds available machines can be selected to cover the whole range of floor care maintenance be it scrubbing, polishing, buffing, burnishing or spray cleaning.

- **Planetary Gearbox**  
Long life, oil filled, low load planetary gearbox.
- **NuLoc 2 Systems**  
Optional pad interchange systems, quick, simple and secure.
- **Hi-Cool Motor**  
1500W motor allowing for higher speeds and the use of added weight as required. Available in a choice of 4 speeds 150rpm, 230rpm, 300rpm, 450rpm.
- **ATC (Automatic Torque Control)**  
Monitoring and balancing power input throughout the cleaning cycle.
- **Fully Adjustable Handle**  
Adjustable for the perfect position.

- **Accessories**  
A range of accessories available to cover wet applications, carpet shampooing, vacuum polishing and floor sanding.



HFM1515



Optional spray clean system

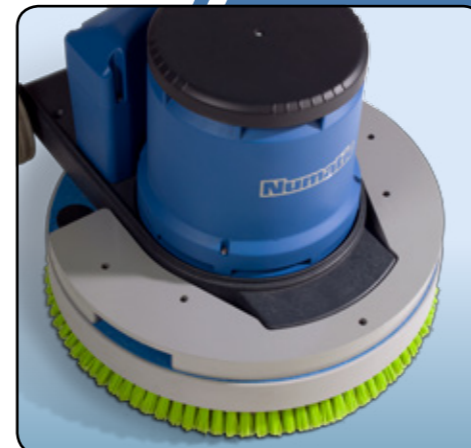

Optional 10Kg additional weight

Model	Motor	Deck	Brush	Pad	Power	Speed	Vacuum	Range	Weight	Dimensions (WxLxH)
HFM1515	1500W	450mm	450mm	400mm	230V AC 50Hz	150rpm	Optional	32m	32kg	460x560x1250mm
HFM1523						230rpm				
HFM1530						300rpm				
HFM1545						450rpm				

# Hurricane *The Two Speed*

There are more and more applications where the floor machine must fulfil two functions literally at the "Flick of a Switch".

The HFT model is fitted with the Hurricane dual performance motor rated at 1000W/1250W providing optimised power options at the two different operating speeds.

For scrubbing you want 150rpm but for polishing 300rpm giving quicker and better results. This is very much the case in hospitals, care homes, hotels, schools, etc. where the needs vary quite substantially each day and two separate machines are not always practical or available.

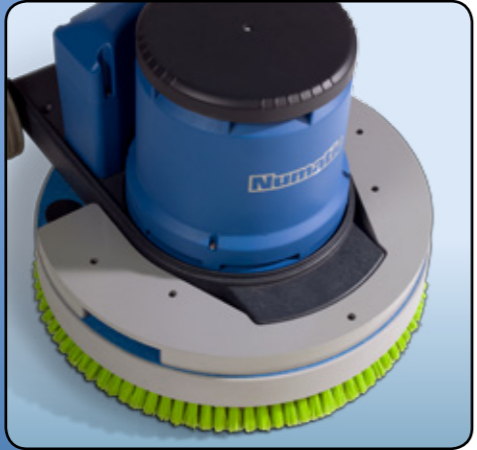
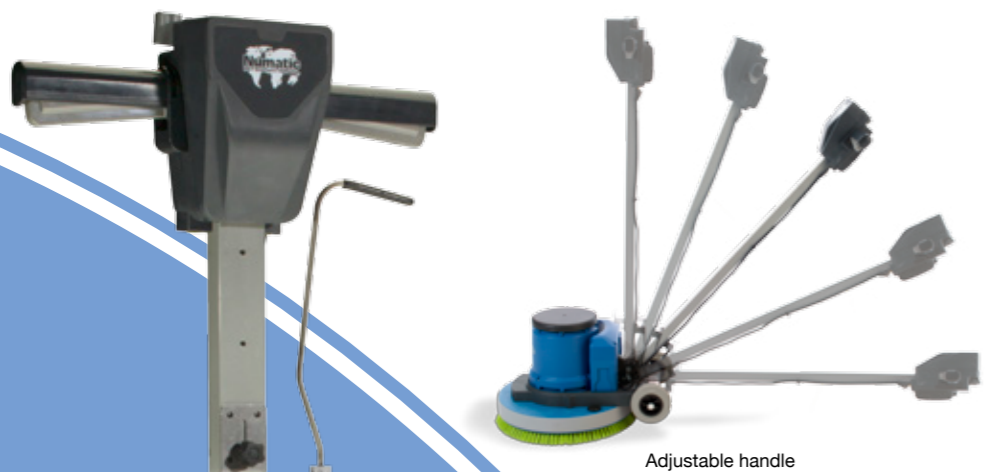

Optional 10Kg Additional weight (150rpm)

HFT1530



HFT Twin speed selection

- **Planetary Gearbox**  
Long life, oil filled, low load planetary gearbox.
- **Dual Speed**  
Dual speed motor giving speeds of 150rpm for scrubbing and 300rpm for polishing.
- **ATC (Automatic Torque Control)**  
Monitoring and balancing power input throughout the cleaning cycle.
- **Accessories**  
A range of accessories available to cover wet applications, carpet shampooing, vacuum polishing and floor sanding.



Easy plugged cable storage

# Hurricane NuShine *The High Speed Burnisher*

Great styling, easy control and powerful. Designed to allow for effortless performance at higher burnishing speeds. When size and weight are a factor the HNS offers the ideal balance.

A compact yet powerful machine with supreme manoeuvrability. If you want stunning results combined with effortless performance then this is the machine for you. The NuShine has complete directional control which means a consistently high standard of finish.

- **Powerful Hi-Cool 1500W Motor**  
Heavy duty, long life motor.
- **Automatic Torque Control**  
Monitoring power and balance.
- **Fully Adjustable Operator Handle**  
Easy to use and fully adjustable operator handle.
- **Effortless**  
Effortless all direction control, superb manoeuvrability.
- **Brush Pressure Monitor**  
Allowing you to be in control of the surface finish achieving optimum results with superior handling.



LCD power / overload indicator

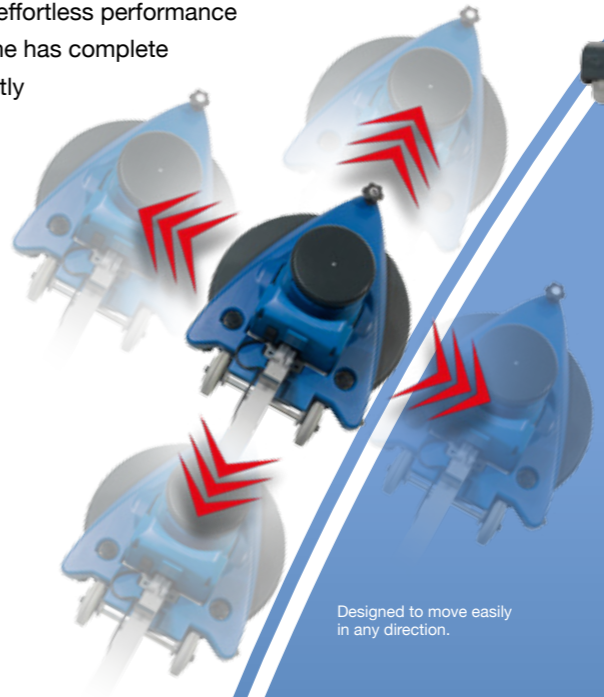

Designed to move easily in any direction.

HNS1550



Simple load adjustment

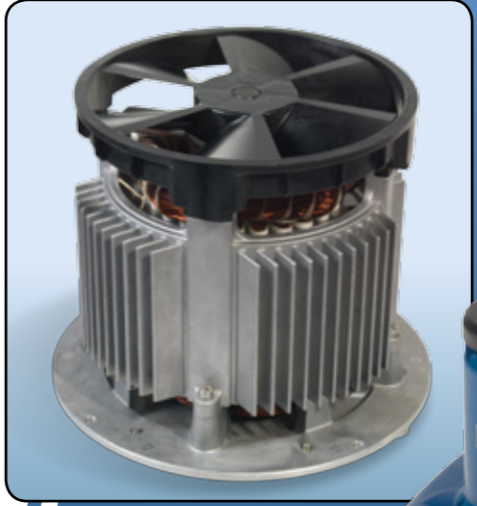

Hurricane Hi-Cool heavy duty motor technology



Model	Motor	Deck	Brush	Pad	Power	Speed	Vacuum	Range	Weight	Dimensions (WxLxH)
HFT1530	1000 / 1250W	450mm	450mm	400mm	230V AC 50Hz	150 / 300rpm	Optional	32m	32kg	460x560x1250mm

Model	Pad	Motor Power	Speed	Pad Pressure	Cleaning Range	Weight	Dimensions (WxLxH)
HNS1550	500mm	1500W	1500rpm	Variable	32m	25kg	560x740x1260mm

# NuSpeed *The Super Compact Size*

The LoLine will put truly usable power, convenience and efficiency in the hands of the operator, giving superb results.

The LoLine rotary has been designed specifically to meet the demand and raise the handling and performance levels to an exceptional user friendly standard.

Our LoLine NLL332 can claim performance characteristics equal to that of bigger, more industrial machines, yet with an ease and speed of operation that will immediately endear it to any user.

A full range of 33cm (13") brushes and pad drives allows the machine to be used for all of the primary floorcare functions.



Solution tank option



Flat folding for easy storage

- **Pads and Brushes**

Full range of 33cm (13") brushes and pad drives for all primary floor care functions.

- **Easy Storage**

Only 18kg in weight, compact size and folding design means easy and convenient to move and store.

- **200rpm**

200rpm means versatility but equals performance of bigger more industrial machines.

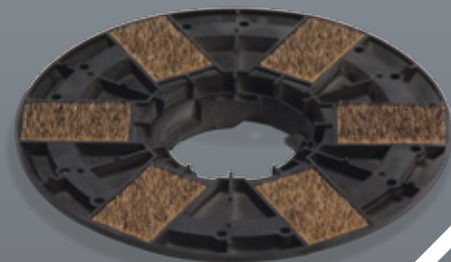

Model	Motor	Deck	Brush	Pad	Power	Speed	Vacuum	Range	Weight	Dimensions (WxLxH)
NLL332	400W	330mm	330mm	330mm	230V AC 50/60Hz	200rpm	-	32m	18kg	450x580x1185mm

8 Images may include optional accessories for illustration purposes.

# NuSpeed *The Full Size*

The NuSpeed range of professional Floorcare machines has been specifically designed to provide optimum results whatever the application.

All NuSpeed NR models within the range are equipped with our performance enhancing ATC (Automatic Torque Control) feature. This is a unique system that monitors operation and boosts torque as required to provide consistent performance under varying load conditions.

- **ATC**

ATC (automatic torque control) monitoring and balancing power input throughout the cleaning cycle.

- **Xtra Weight**

Unique Nuspeed design means an increase in operating weight of 40kg can be achieved within the standard specification.

- **Easy Storage**

Compact size and folding handle means easy and convenient to move and store.



Planetary gearbox



NR1500 folded for storage.



NR1500



See page 32 for full accessories

Model	Motor	Deck	Brush	Pad	Power	Speed	Vacuum	Range	Weight	Dimensions (WxLxH)
NR1500S	1500W	400mm	450mm	400mm	230V AC 50/60Hz	150rpm	Optional	32m	40kg	460x580x1250mm

# TwinTec *The Cylinder Machine*

Designed to be compact, easy to operate and exceptionally manoeuvrable when in use, whilst the oversized transit wheels allow easy movement to and from any specific locations.

The cylinder power brush ensures deep cleaning performance, whilst the twin water pickup nozzles allow multi-directional operation which is vitally important when cleaning narrow walkways often found in shops and food stores. You can walk in forwards and reverse out without turning and without loss of scrubbing and drying performance.

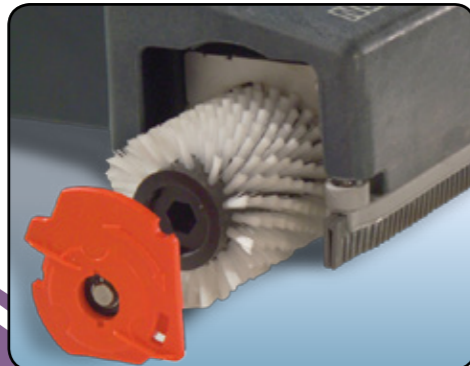

Simple brush access

TT1535



Overfill cut off system

- **Compact**  
Yet exceptionally manoeuvrable.
- **Multidirectional**  
Twin water pickup nozzles for all round cleaning.
- **Cylinder Power Brush**  
Ensures deep cleaning.
- **Swing Steering**  
Provides easy directional control.
- **Transit Wheels**  
Oversized transit wheels allow easy movement to and from any location.
- **Simple Control**  
Easy to use operator controls.



Adjustable water flow



Operator controls

# TwinTec *The Compact Single Disc*

The TwinTec 1840 cable machine has been designed to address the question of size being exceptionally compact, yet with performance equal to bigger machines.

The compact design really does allow this machine to clean in areas normally cleaned by hand, yet 30% to 40% faster and better.

Although designed for small and congested areas the TT1840 is equally at home in larger areas and can be used in conjunction with our cable roll, "the cable reel that rolls", extending the cable length from 20m to 40m without any loss of performance.

The style and proportion of the polyform water tanks allow for the machine to adopt a convenient tilt position with only approximately 5 litres in the clean water tank to facilitate single handed brush or pad changing.



TT1840

20m Cable reel

- **Water Feed System**  
360° liquid feed for uniform delivery.
- **Convenient**  
Fold flat design for easy transport from site to site.
- **Rugged Construction**  
Tough all steel chassis design.
- **Fully Adjustable Handle**  
For the perfect working position.
- **Low Noise**  
Quieter, unobtrusive design means true versatility.
- **Easy Change**  
Easy one handed brush or pad changing.



Visible operation



Simple controls



Easy and generous fill cap

Model	Brush Motor	Vac Motor	Power	Brush Speed	Range	Brush Width	Capacity	Weight	Dimensions (WxLxH)
TT1535S	400W	1000W	220-240V 50Hz	1000rpm	42m	450mm	15L	38kg	480x750x740mm

Model	Brush Motor	Vac Motor	Power	Brush Speed	Range	Pad/Brush Width	Capacity	Weight	Dimensions (WxLxH)
TT1840	400W	300W	220-240V 50Hz	150rpm	42m	360/400mm	18L	40kg	520x880x1132mm

The EcoTec Economy 4045 is designed to provide an exceptional “value for money” professional machine and to clean to a professional standard.

The very big advantage of the cable electric machines is the exceptional power and performance available to clean floors that are both rough and excessively dirty.

Two cost saving specification changes have been made compared with the TT premium model, being a nutex epoxy powder coated chassis in place of stainless steel and a Structofoam floor tool in place of aluminium.



ET4045

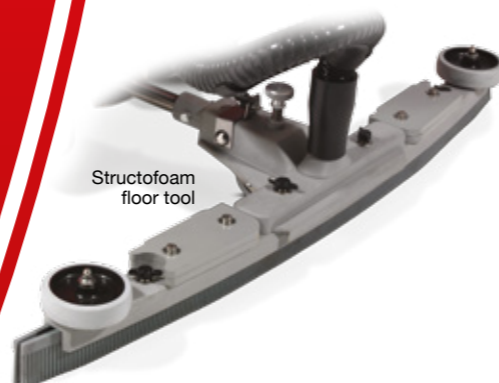

Structofoam floor tool



Non-marking wheels

- **Nutex Chassis**  
Nutex epoxy powder coated chassis.
- **Planetary Gearbox**  
Numatic high efficiency long life gearbox.
- **Structofoam Tilting Brush Deck**  
Making brush changes quick and simple.
- **Polyform Tanks**  
Heavy duty clean and dirty water tanks.
- **Twinflo Vacuum Motor**  
Provides exceptional wet pick up.
- **Fully Adjustable Handle**  
For the perfect working position.
- **Simple Control System**  
Soft touch Nutronic controls.



Flexifill 1m easy fill hose

# TwinTec *A Range of Two*

The TwinTec mains cable range has masterful performance moving under its own brush power with amazing speed and purpose. Available with 45 or 55cm scrub width.

When selecting a scrubber dryer machine, the area that needs to be cleaned and the time available to clean it will determine the preferred size of the brush system.



TT4045

TT4055

Care must be taken, however, to ensure that bigger is better but not too big, taking into account the obstructions that must be navigated during the daily cleaning cycle.

- **Twinflo Vacuum Motor**  
Provides exceptional wet pick up.
- **Structofoam Tilting Brush Deck**  
Making brush changes quick and simple.
- **Planetary Gearbox.**  
Long life, oil filled, low load gearbox.
- **Simple Control**  
Simple on / off trigger control.
- **Polyform Tanks**  
Heavy duty clean and dirty water tanks.
- **Stainless Chassis**  
Strong full stainless steel chassis.
- **Flexifill System**  
Easy filling and emptying system.



Flexifill 1m easy fill hose

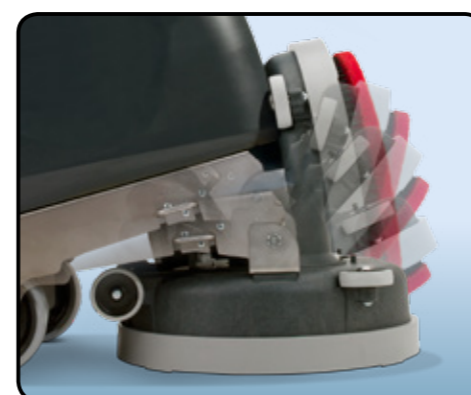

Tilting deck for easy brush change and storage

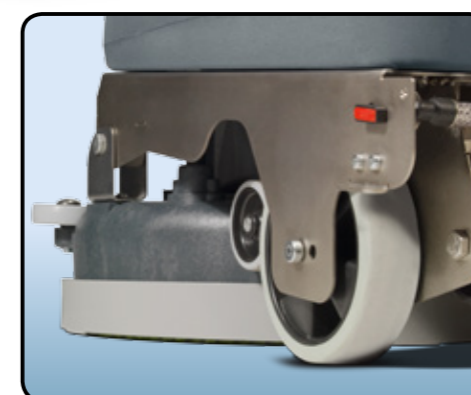

Full stainless steel chassis and non marking wheels

Model	Brush Motor	Vac Motor	Power	Brush Speed	Range	Pad/Brush width	Capacity	Weight	Dimensions WxLxH
ET4045	1500W	1000W	220-240V 50Hz	150rpm	42m	400/450mm	40L	57kg	470x890x1180mm

Model	Brush Motor	Vac Motor	Power	Brush Speed	Range	Pad/Brush Width	Capacity	Weight	Dimensions (WxLxH)
TT4045	1500W	1200W	220-240V 50Hz	150rpm	42m	400/450mm	40L	67kg	470x890x1100mm
TT4055						500/550mm			

# TwinTec *Big & Bold*

The TT6650 cable machine is a genuine workhorse providing a truly cost effective answer to big area low cost floor maintenance.

First and foremost the user will find the TT6650 as easy to use as our smaller machines with the control and operation systems to exactly the same specification, it handles like a dream.

Big capacity polyform tanks provide a full 60 litre capacity to match the exceptionally stable 65cm single brush scrubbing head, complemented by an oversized, floating aluminium floor tool.

- **Polyform Tanks**  
Heavy duty clean and dirty water tanks.
- **Structofoam Tilting Brush Deck**  
Making brush changes quick and simple.
- **Fully Adjustable Handle**  
For the perfect working position.
- **Twinflo Vacuum Motor**  
Provides exceptional wet pick up.
- **Stainless Chassis**  
Strong stainless steel chassis.

Tilting deck for easy brush / pad change and storage

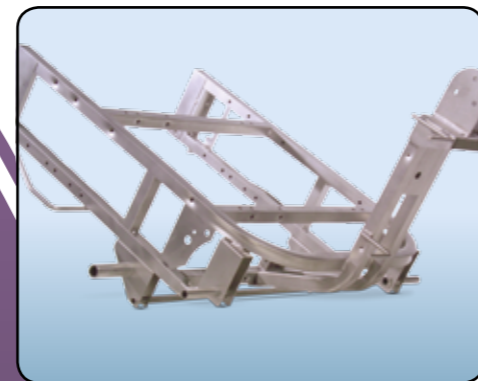

Stainless steel chassis



Easy tank filling access



TT6650

Model	Brush Motor	Vac Motor	Power	Brush Speed	Range	Pad/Brush Width	Capacity	Weight	Dimensions (WxLxH)
TT6650	1500W	1200W	220-240V 50Hz	150rpm	42m	635/600mm	60L	87.6kg	970x1260x1230mm

# TwinTec *Battery Compact*

The TwinTec 1840 cable machine has been designed to address the question of size being exceptionally compact, yet with performance equal to bigger machines.

The compact design really does allow this machine to clean in areas normally cleaned by hand, yet 30% to 40% faster and better.

- **Cable Free**  
Total freedom of 24V battery operation.
- **Battery Pack**  
Quick change 24V gel battery pack.
- **Water Feed System**  
360° water feed system for uniform liquid delivery to floor.
- **Fully Adjustable Handle**  
Flat to upright for perfect position.
- **Parabolic Squeegee**  
270° rotating parabolic squeegee system.
- **Quick Change**  
Fast, single handed brush or pad changing.
- **Hi / Lo Mode**  
For quieter cleaning when needed.

Folds down very small for easy storage or transit



TTB1840



Simple soft touch controls



Easy and generous fill cap

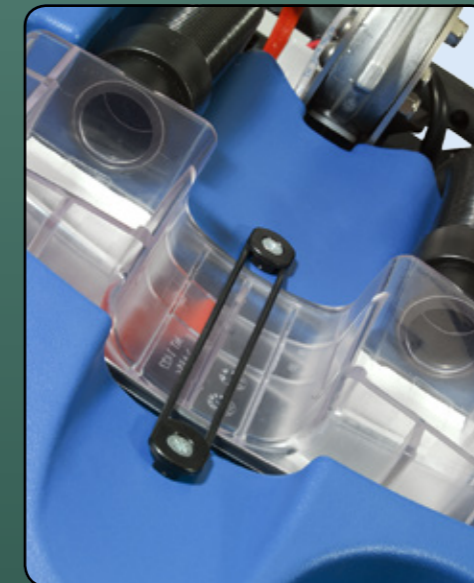

Visible operation



Quick change gel battery pack

Model	Brush Motor	Vac Motor	Power	Run Time	Recharge Time	Pad/Brush Width	Capacity	Weight	Brush Speed	Dimensions WxLxH
TTB1840	400W	300W	2x12V (24V 18Ah)	45min	6hrs	360/400mm	18L	52kg	150rpm	520x850x1132mm



# EcoTec Battery *Value & Performance*

## The EcoTec Economy 4045 is designed to provide an exceptional “value for money” professional machine.

The ETB4045 has a number of cost saving variations introduced into the specification without loss of performance or operating life. The LoLine chassis is manufactured in nutex epoxy powder coated steel in place of stainless steel; the wet pick up floor tool is Structofoam rather than aluminium and the machine is fitted with fully sealed 60Ahr gel batteries.

- On Board Charging**  
 Convenient and easy, just plug and go.
- Fully Sealed Gel Batteries**  
 Maintenance-free batteries to ensure the highest standard of operational life.
- Structofoam Tilting Brush Deck**  
 Making brush and pad changing quick and easy.
- Polyform Tanks**  
 Tough Polyform clean and dirty water tanks.
- Twinflo Vacuum Motor**  
 Provides exceptional wet pick up.
- Flexifill System**  
 Easy filling and emptying with Flexifill system.



ETB4045



Structofoam wet pick up floor tool



Easy access battery compartment



Flexifill 1m easy fill hose

Model	Brush Motor	Vac Motor	Power	Run Time	Recharge Time	Pad/Brush Width	Capacity	Weight	Brush Speed	Dimensions WxLxH
ETB4045	400W	400W	2x12V (24V 60Ah)	2hrs	6hrs	400/450mm	40L	103kg	100rpm	470x1030x1160mm

# TwinTec Battery *Setting the Standard*

## With these machines every part is designed to combine the best in functionality and reliability.

The TTB4045 is the classic Numatic TwinTec 24V battery model. It started its life with 30 litre capacity, now raised to 40 litre, and is today the most popular model worldwide. The premium specification starts with a full stainless steel chassis, Structofoam tilting brush deck, polyform tanks, fully sealed gel batteries, built in battery charger, heavy duty TwinFlo wet pick up vacuum system and heavy duty geared brush drive.

The 4055 is one size up from the 4045 containing all the advanced TwinTec 24V features but with a 20% increased cleaning path.

The 4055T (traction) offers effortless cleaning due to the powerful traction unit. A traction model is essential where inclines such as wheelchair ramps are present.



TTB4045

TTB4055  
TTB4055T

- Fully Sealed Gel Batteries**  
 Maintenance-free batteries to ensure the highest standard of operational life.
- Twinflo Vacuum Motor**  
 Provides exceptional wet pick up.
- Structofoam Tilting Brush Deck**  
 Making brush and pad changing quick and easy.
- Easy Operation**  
 Simple on / off trigger control.
- Stainless Steel Chassis**  
 Strong, long life, low maintenance.
- On Board Charging**  
 Convenient and easy, just plug and go.
- Hi / Lo Mode**  
 For quieter cleaning when required.



Soft touch Nutronic controls



On-board charger



Additional fill and filter point



Battery isolator key

Model	Brush Motor	Vac Motor	Power	Run Time	Recharge Time	Pad/Brush Width	Capacity	Weight	Traction Drive	Brush Speed	Dimensions WxLxH
TTB4045				2.25Hrs		400/450mm		128kg			470x1075x1160mm
TTB4055	400W	400W	2x12V (24V 100Ah)		8hrs	500/550mm	40L	134kg		100rpm	560x1115x1160mm
TTB4055T				2.3Hrs		500/550mm		140kg	250W		

T= Traction drive

# TwinTec Battery *Twin Brush Power and Performance*

All the specification of other TwinTec models with the addition of a twin brush deep power cleaning system.

For more demanding high resistance floor surfaces the Twin Brush is often the preferred choice giving optimal performance in any situation.

There are two variations within this model, one with and one without the powered traction drive. The traction drive model must be selected for applications where inclines or wheelchair access ramps are part of the cleaning programme.

...Twin Brush Power and Performance



On-board charger



Unique flip-deck

- **Traction Drive System**  
Makes the cleaning of inclines safer and easier. TTB4552T only.
- **Fully Sealed Gel Batteries**  
Maintenance-free batteries to ensure the highest standard of operational life.
- **On Board Charging**  
Convenient and easy, just plug and go.
- **Stainless Steel Chassis**  
Strong, long life, low maintenance.
- **Polyform Tanks**  
Tough Polyform clean and dirty water tanks.

- **Fully Adjustable Handle**  
For the perfect working position.
- **Hours Meter**  
Monitors operational hours for service intervals.
- **Unique Flip Deck**  
Easy to change pads and brushes with the flip up deck feature.



TTB4552/T



TTB4552  
Twin Brush

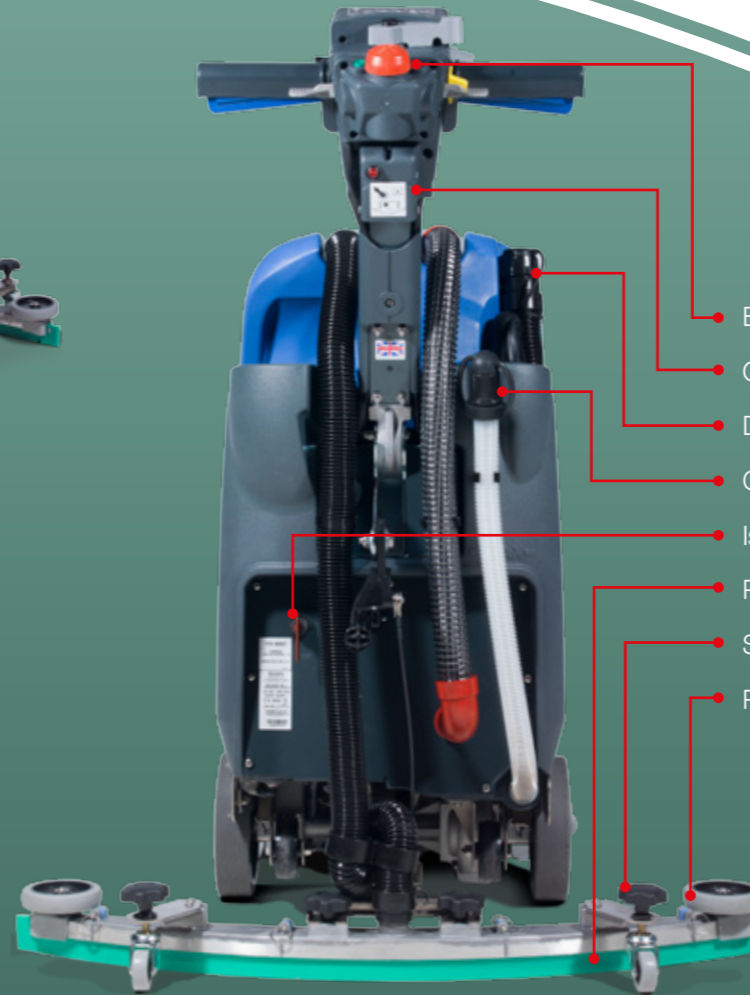

- Emergency stop button
- On-board charger
- Dirty water dump hose
- Clean water dump hose
- Isolator key
- Polyurethane squeegee
- Squeegee height adjusters
- Rotating buffers



Soft touch Nutronic controls

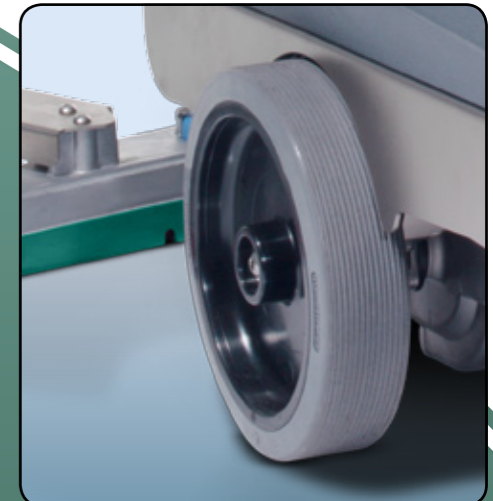

Traction drive option



Additional fill and filter point

Model	Brush Motor	Vac Motor	Power	Run Time	Recharge Time	Pad/Brush Width	Capacity	Weight	Drive Speed	Brush Speed	Dimensions WxLxH
TTB4552	2x400W	400W	2x12V (24V 100Ah)	2Hrs	8hrs	2x280mm	40L	134kg	-	120rpm	565x1145 x1160mm
TTB4552T								144kg			

T= Traction drive

# TwinTec Battery *50% More Capacity for bigger areas*

## Easy-to-use controls combined with professional cleaning.

The 55cm (20") size of TwinTec is becoming more and more popular and, in support of this, we have introduced two new models with 60 litre capacity, a 50% increase over the 40 litre models and available in both traction and non-traction specifications.

Both models of TTB6055 have 60 litre capacity and a 55cm (20") single brush scrubbing path, dual brush pressure selection, built in battery charging, easy fill and easy emptying facilities, with added traction power drive for the 6055T model which would be essential if inclines or ramps are involved.

*...50% More Capacity for bigger areas*



Plug-in charger system



Flexifill 1m filling hose

- **Simple Operator Controls**  
Soft touch Nutronic control panel.
- **Traction Drive System**  
Makes the cleaning of inclines safer and easier (TTB6055T).
- **On Board Charging**  
Convenient and easy, just plug and go.
- **Full Cleaning Control**  
Individual speed and water flow rate settings for full control.
- **Flexifill System**  
Easy filling and emptying with flexifill system.
- **Fully Sealed Gel Batteries**  
Maintenance-free batteries to ensure the highest standard of operational life.

Simple to use Nutronic control panel TTB6055 shown

- Security key
- Water flow indicator
- Hi / Lo mode
- Vacuum only mode
- Brush pressure indicator
- Battery life indicator



TTB6055



Easy battery access

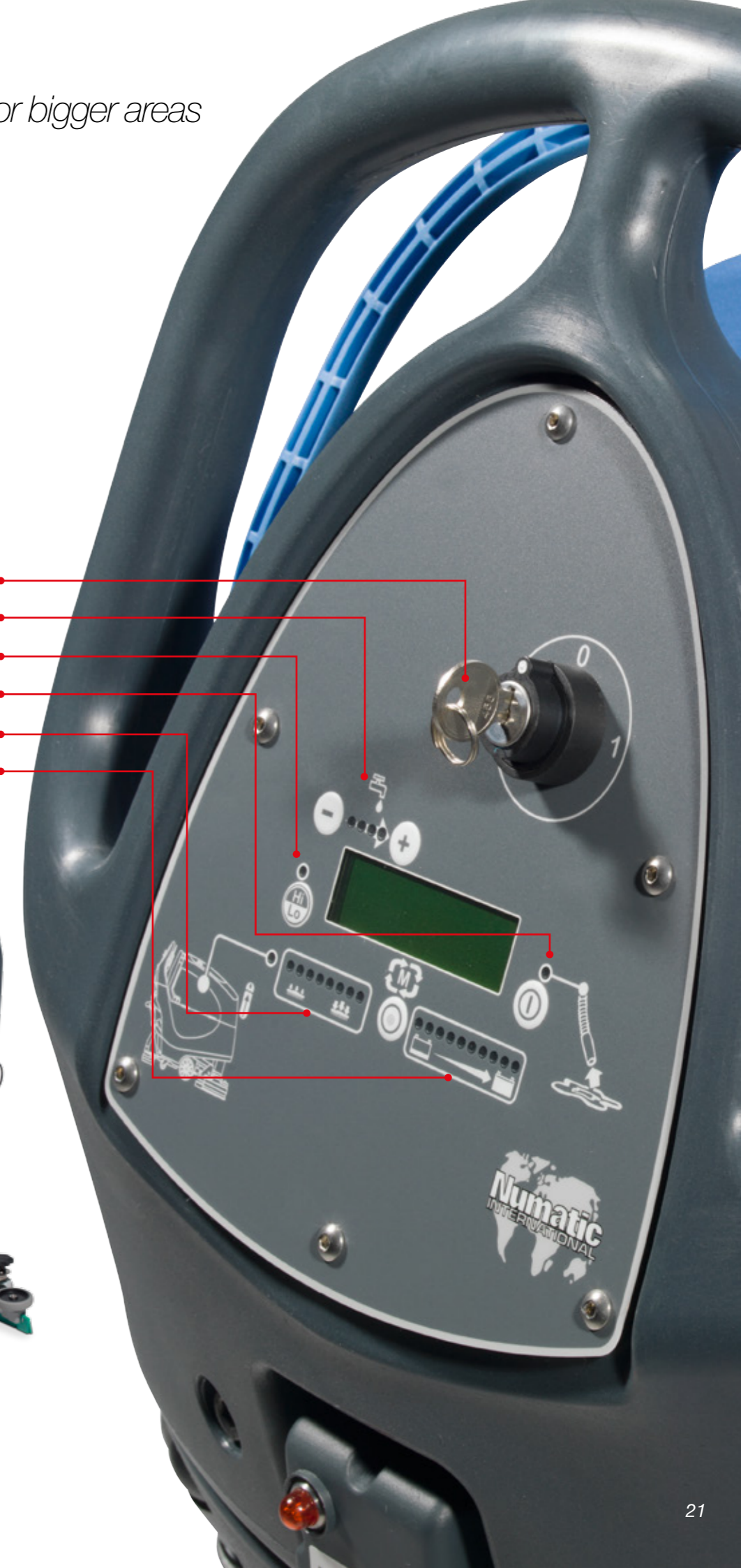

Model	Brush Motor	Vac Motor	Power	Run Time	Recharge Time	Pad/Brush Width	Capacity	Weight	Drive Speed	Brush Speed	Dimensions WxLxH
TTB6055	400W	400W	2x12V (24V 100Ah)	2.25Hrs	3-4hrs	500/550mm	60L	158kg	-	100rpm	550x1280x1160mm
TTB6055/T									4.2kph		

T= Traction drive

# TwinTec Vario *Two Into One Does Go*

The TwinTec Vario 4555 provides a smaller machine yet with all the advanced and time tested features of the bigger walk behind model.

The TwinTec Vario 4555 has taken the very best technology from other models in the Vario range and integrated these features into one of the most compact, hard working, professional floor maintenance machines with a choice of either 45cm or 55cm scrubbing widths by virtue of the adjustable dual setting Vario deck design.

What has been achieved, both in terms of performance and handling, is truly outstanding, resulting in a machine that will become the preferred choice of many contractors servicing medium size contracts where overall machine size is an important user consideration.



- Variable speed control
- Security key
- One touch dosing control
- Emergency stop
- Plug-in charger system
- Flexifill extending nozzle

- Brush pressure controls
- Clean water dump hose
- Stainless steel chassis
- Squeegee height adjusters
- Rotating buffers

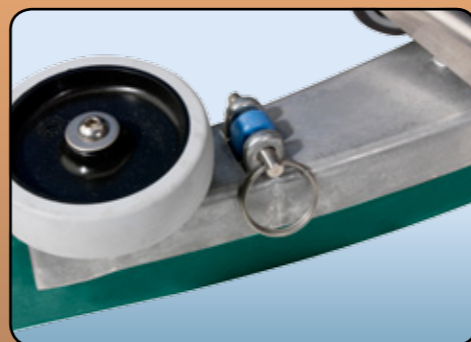

Easy change squeegee



Flexifill 1m easy fill hose

*...Two Into One Does Go*



Adjustable 45/55cm scrub deck

TTV4555



Easy battery access

- **Adjustable Scrub Widths**  
45cm or 55cm scrubbing width by virtue of the adjustable dual setting Vario deck design.
- **On Board Charging**  
Convenient and easy, just plug and go.
- **Complete Cleaning Control**  
Simple one touch dosing and versatile variable speed control.
- **Fully Sealed Gel Batteries**  
Maintenance-free batteries to ensure the highest standard of operational life.
- **Simple Operator Control**  
Nutronic soft touch operator controls.

- **Flexifill System**  
Easy filling and emptying with flexifill system.
- **Safety Features**  
Built in emergency stop button and removable power off security key are just two of the many safety features.

Model	Brush Motor	Power	Vac Motor	Cleaning Speed	Pad/Brush Sizes	Net Weight	Run Time	Water Capacity	NuChem Capacity
TTV4555	400W	2 x 12V =100Ahr	400W	0 - 4.2kph	400/500mm 450/550mm	158kg	2.25hrs	60L	5L
Water Flow Rate	NuChem Mix	Max Climbing Gradient	Scrub Widths	Brush Speed	Dimensions (WxLxH)				
0.5, 1, 2, 3 L/min	100:1 75:1 50:1 25:1	9%	450/550mm	100rpm	550x1280x1160mm				

With a full 60 litre capacity, built in dosing and dual brush pressure, true versatility is the principal objective, not to mention built in battery charging, easy fill and emptying systems adding to the high level of user convenience and satisfaction.

# TwinTec Vario *Two Into One Goes Again, Even Bigger*

The TwinTec Vario 5565 represents, in every way, the optimum walk behind traction auto-scrubber with a range of advanced, yet practical, features that truly allow us to claim... "Best in Class".

This TwinTec gets its Vario name from the fact that this one machine can, by a no tools adjustment and simple brush change, be set to operate at either a 55cm or 65cm scrubbing width... two machine choices in one.



## ...Two Into One Goes Again, Even Bigger

- Flexifill System**  
 Easy filling and emptying with the flexifill system.
- Complete Cleaning Control**  
 Simple one touch dosing control and versatile variable speed control.
- Adjustable Scrub Widths**  
 55cm or 65cm scrubbing width by virtue of the adjustable dual setting Vario deck design.
- Spot Cleaning**  
 Heavy duty spot cleaning means operator can over-ride standard brush pressure to 50kg for extra performance.
- Easy Transportation**  
 Built in easy transit mode for easy transportation between areas.
- On Board Charging**  
 Convenient and easy, just plug and go. Fully sealed low maintenance gel batteries.
- Simple Operator Control**  
 Nutronic soft touch operator controls.
- Safety Features**  
 Built in emergency stop button and removable power off key are just two of the many safety features.



Easy battery access

Beneath the hinged dirty water tank sits the operating heart of the Vario with its 200Ahr gel battery and charging system, high performance suction unit and NuChem dosing facility... all easily accessible.



TTV5565

In the 65cm mode the scrubbing head is automatically expanded to a practical offset operating mode, providing a 100mm head extension to the right hand side. This simple arrangement allows improved edge cleaning especially in aisles with racking or other obstructions.

The operator controls are a separate feature in their own right with independent selection of speed, water flow and chemical dosing all built in to the basic unit, all of which can be set to provide total convenience and consistency of operation.



Simple to use Nutronic control panel

## The unique Twintec 55cm/65cm dual brush system...

A simple, no tool adjustment and brush change allows a selection of either 55cm or 65cm scrubbing widths.

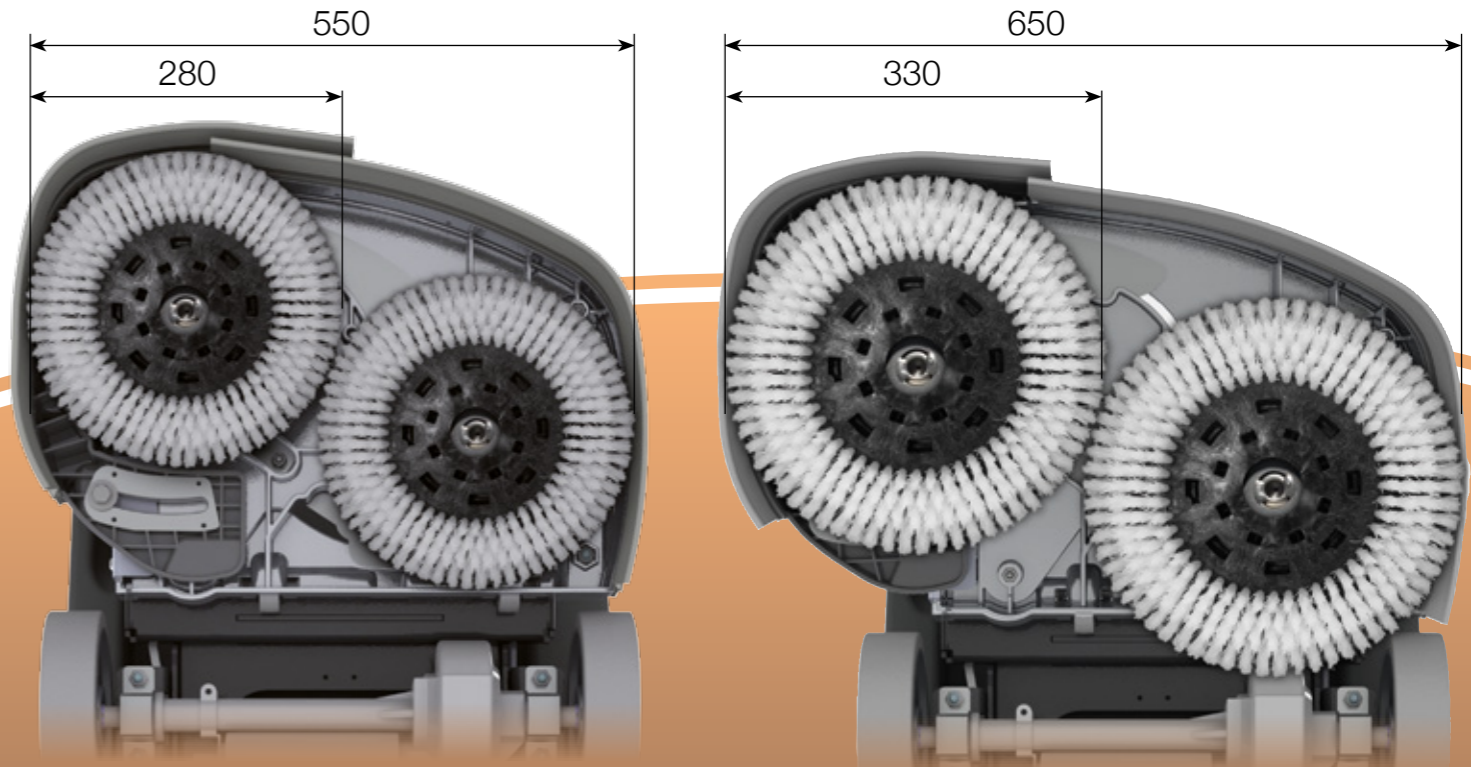

Model	Brush Motor	Vac Motor	Power	Run Time	Traction Drive	Drive Speed	Cleaning Speed	Climbing Gradient	Scrub Widths
TTV5565	2x400W	600W	4 x 12V (24V) = 200Ahr	3.5 Hrs	480W	4.2km/h	4.2km/h	9%	550mm 650mm
Brush Speed	Water Capacity	NuChem Capacity	Water Flow Rate	NuChem Mix	Weight	Dimensions (WxLxH)			
200rpm	85L	Optional 5L	3, 2, 1, .5L/min	25:1, 50:1, 75:1, 100:1	287kgs	585x1400x1135mm			

# Compact Ride-on *Compact "Go Anywhere"*

**Not too big, not too small, good capacity, simple controls, excellent performance and very competitive in terms of price.**

In truth the CRO8055 is competitive with most walk behinds of the same size. So now you can sit rather than walk and by virtue of the exceptional manoeuvrability, substantial time will be saved on middle size applications.

The CRO8055 also introduces the logic of two machines in place of something much bigger or, to put it another way, Two for the Price of One with added versatility and convenience.

The CRO will go into places where bigger machines are not suitable and anything smaller is just too small.

*...The Compact "Go Anywhere" Ride-on*

- **Compact Design**  
Means easy cleaning in tight spaces.
- **Anti Tip System**  
Prevents the machine from tipping when cornering on full lock.
- **On Board Charging**  
Easy and convenient, just plug and go. Fully sealed low maintenance Gel batteries.
- **Flexifill System**  
Easy filling and emptying with the flexifill system.
- **Easy Operator Control**  
With fully adjustable speed control.



CRO8055

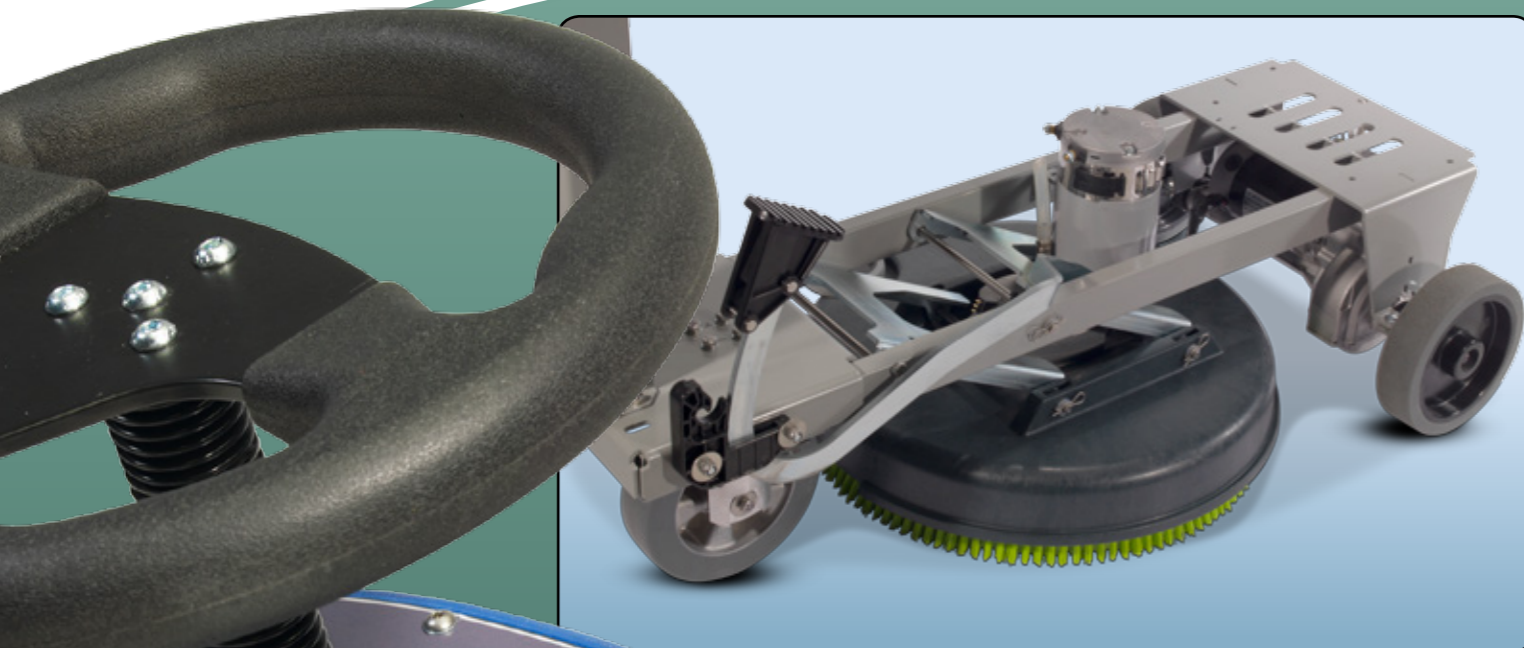

Heavy duty integral chassis

- **Safety Features**  
Emergency stop button, removable power off key, horn button and built in hazard warning light are just a few of the safety features included.
- **Easy Maintenance**  
Easy access to batteries and fuses for maintenance.



Flexi fill hose



Charger port



Easy battery access



Anti-tip side buffers

Model	Brush Diameter	Capacity	Battery Power	Run Time	Traction Drive	Clean Speed	Vacuum Motor	Brush Speed	Brush Motor	Dimensions (WxLxH)
CRO8055	550mm	80L	2 x 12V (24V) = 120 Ahr 2 x 12V (24V) = 100 Ahr	3h 2h	400W	6km/h max	400W	150rpm	1 x 600W	805x1460x1160mm

# TwinTec Ride-on *A Serious Workhorse*

A more user friendly ride on scrubber dryer would be hard to find. Designed to provide long, simple and reliable service day in day out whatever the environment.

The TRO650 is based on the well established engineering of the Vario TTV678 model but simplified to provide a truly professional, cost effective workhorse. You can vary the water flow and the operating speed to suit a whole host of conditions from big areas lightly soiled to heavy duty scrubbing in more arduous conditions.



TRO650



Easy brush access

The TRO650 is blessed with a commanding operator driving position, front wheel traction drive, a magnificent turning circle and one pass performance that really will ensure you get the standard you want, exactly when you want it... and fast.

## ...A Serious Two Brush Workhorse

- Twin Brush**  
 650 twin brush power head cleaning system.
- Easy Brush Access**  
 Easy side access to brushes for maintenance.
- Controlled Cleaning**  
 Fully adjustable water flow rate.
- On Board Charging**  
 Easy and convenient, just plug and go. Fully sealed low maintenance Gel batteries.
- Simple Operator Control**  
 Full dashboard control with soft touch Nutronic controls.
- Safety Features**  
 Emergency stop button, power off removable key, horn button and hazard warning light and built in reversing alarm are just a few of the many safety features included.
- Easy Maintenance**  
 Easy access to batteries and fuses for maintenance.



Full control dashboard

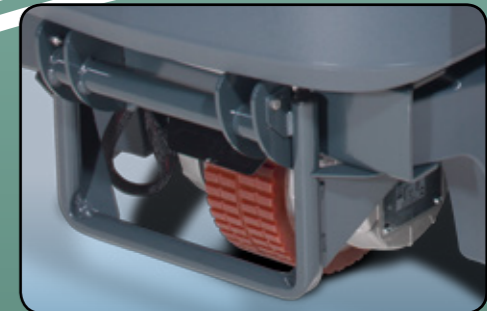

Drive wheel protector

A full 120 litre capacity with a fixed 650mm twin brush power head the TRO650 is ready to go.



Easy maintenance access

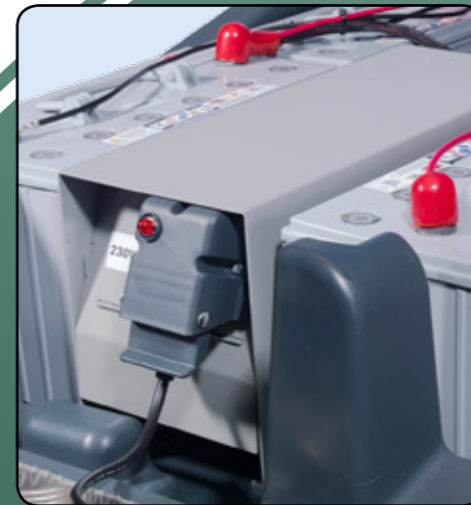

Onboard charging



TRO Aluminium / Polyurethane floor tool



Model	Brush Motor	Vac Motor	Power	Run Time	Traction Drive	Drive Speed	Cleaning Speed
TRO650	2 x 400W	400W	4 x 12V (24V) = 200Ahr	3.5 Hrs	600W	0-7.0km/h	3.5km/h
Scrub Width	Brush Speed	Water Capacity	Water Flow Rate	Climbing Gradient	Weight	Dimensions (WxLxH)	
650	200rpm	120L	3, 2, 1, 0.5L/min	11%	365kgs	944x1676x1425mm	

# TwinTec Vario *Three Into One Does Go*

**A comfortable, driver friendly, 120-litre, front wheel drive machine with a fantastic turning radius, gets in and out of places other machines just won't go.**

The TwinTec Vario "three in one" (3 in 1) design has proved itself to be almost the perfect balance between sound common sense engineering and innovative and truly functional technology.

Yes, one machine which can be set to 3 different working widths: 650, 750 and 850 and all at the flick of a simple selection lever. This doesn't even need tools – anybody can do it at any time. You want it wide – fine... you want it narrow – 30 seconds is all that it takes.



TTV678

## The Vario TTV678, three brush widths in one system

The unique arrangement of 3 independent scrubbing heads which, by virtue of a simple adjustment mechanism, can provide a choice of scrubbing widths which, with the addition of a selection of brushes and pads, can provide customised performance on almost any surface application.

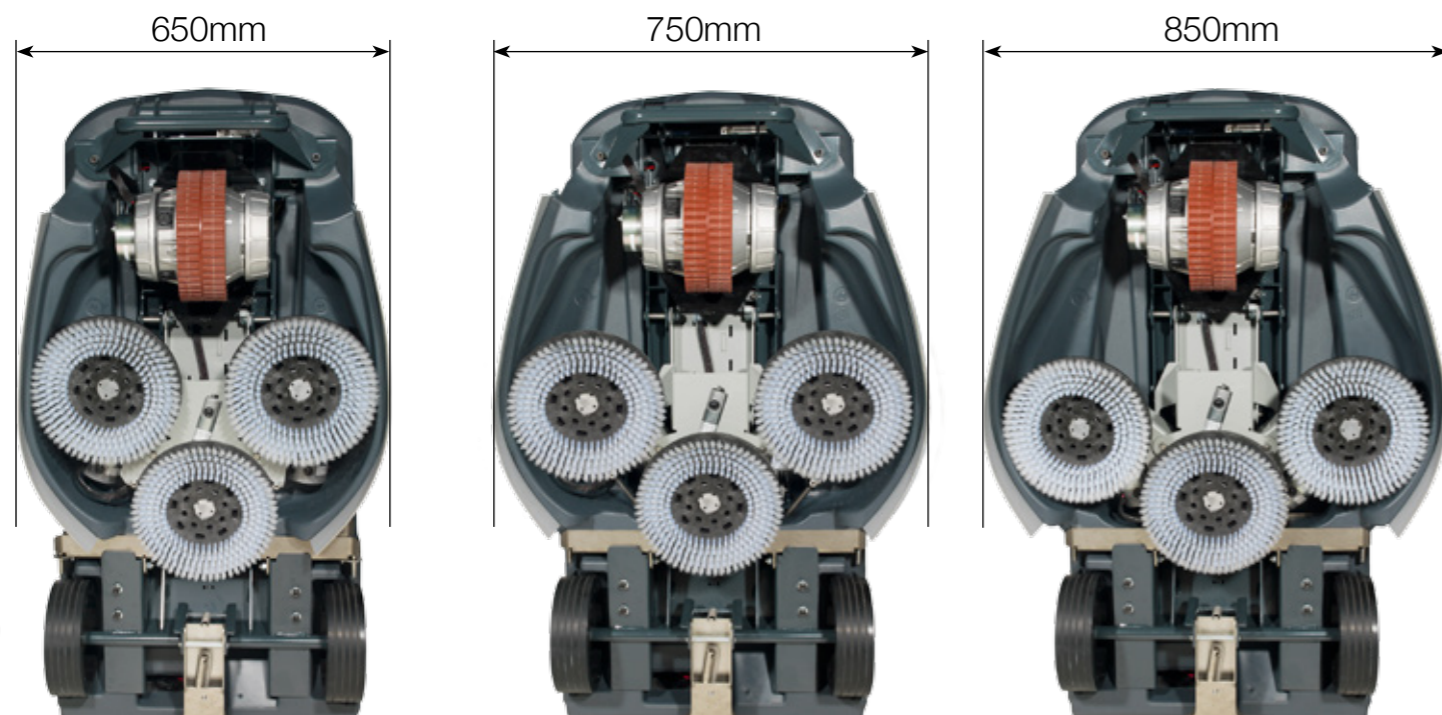

*As unique today as when it started - patented technology*

- Vario 3 In 1 Brush System**  
 Simple adjustment mechanism provides a choice of scrubbing widths suitable for almost any surface.
- Easy Dosing Pre-sets**  
 Correct chemical dosing for every task.
- Complete Cleaning Control**  
 Operator has full control of cleaning speed, brush speed, water flow and chemical dosing.
- Simple Operator Control**  
 Soft touch dashboard control system.
- Easy Maintenance**  
 Easy access to batteries and fuses for service purposes and brush change is simple with the swing out brush cover.
- On Board Charger**  
 Simple and convenient, just plug and go. Fully sealed low maintenance Gel batteries.
- Small Turning Radius**  
 Means great cleaning even in tight spaces.
- Safety Features**  
 Emergency stop button, power off removable key, horn button and hazard warning light and built in reversing alarm are just a few of the many safety features included.
- Easy Maintenance**  
 Easy access to batteries and fuses for maintenance.



Control panel

## Vario, the machine that gives you what you want.

In many applications changing circumstances change specific needs, so with the Vario you can change the specification to suit your exact requirements. It's not only the working widths that can be changed; it's the full operating performance that is under the driver's complete control – cleaning speed, brush speed, water flow and chemical dosing, nothing left to chance.

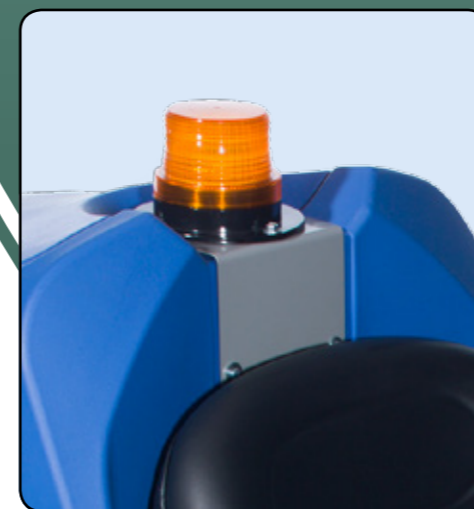

Hazard light

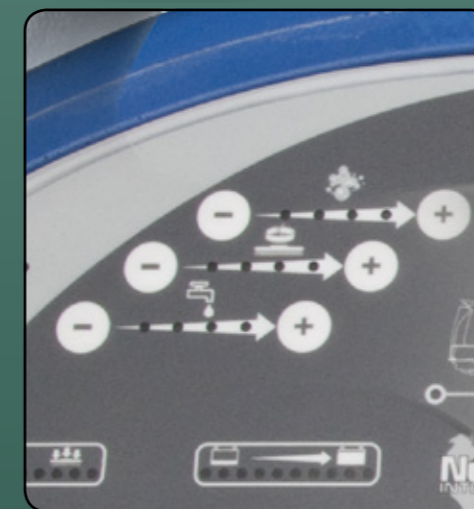

Dosing controls

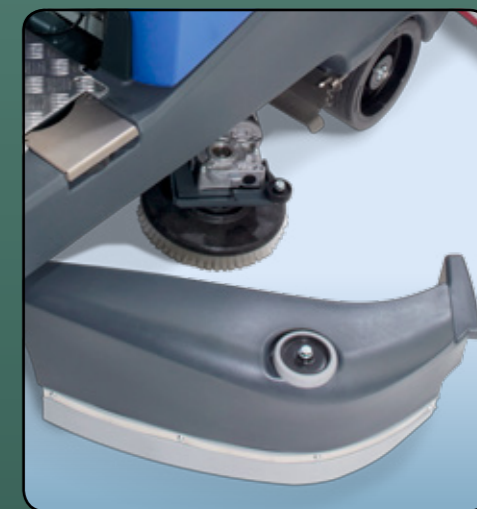

Easy brush change

Model	Brush Motor	Vac Motor	Power	Run Time	Traction Drive	Drive Speed	Cleaning Speed	Climbing Gradient
TTV678	3x24V 400W	24V 400W	6 x 12V (24V) = 300Ahr 8 x 12V (24V) = 400Ahr (Optional)	3.5 Hrs 4.5 Hrs	600W	7.0km/h	3.5km/h	11%
Scrub Widths	Brush Speed	Water Capacity	NuChem Capacity	Water Flow Rate	NuChem Mix	Gross Weight (full)	Dimensions (HxLxW)	
650mm 750mm 850mm	50/100/ 150/200rpm	120L	Optional 5L	4L/min 3L/min 2L/min 1L/min	25:1 50:1 75:1 100:1	6x12V+620kgs 8x12V+684kgs	1425x1676x1054mm	

(See page 32 for full accessories) 31





# Accessories

Using genuine Numatic accessories will ensure you achieve the best results from your Floorcare machine.

Each accessory is developed with professional cleaners in mind, good quality design makes all the difference when a task is repeated day after day.

## Hurricane and NuSpeed Accessories



HFS / HFM Solution Tank PN:606890



NR Solution Tank PN:606084



NLL Solution Tank PN:606101



NR 10Kg Weight For NR 1500S PN:606113  
HFM 10Kg Weight For HFM 1500S PN:606077



HFM / NPR Dustrol Kit (Blue) PN:606178  
HNS 1550 Dustrol Kit (Blue) PN:900834  
NR Dustrol Kit (Grey) PN:606056  
HFM/NR Dustrol Control Brush Ring (Also Standard With Dustrol Kits) PN:606079



NR Optional Spraytec Kit PN:606054  
HFM/HNS Optional Spraytec Kit PN:606325

## TwinTec / Vario Blade Sets



TT / TTB1840 Replacement Blade Set (2 pieces) PN:606261

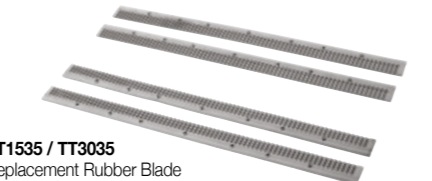

TT1535 / TT3035 Replacement Rubber Blade Set (4 pieces) PN:606057



ET4045 / ETB4045 Replacement Rubber Blade Set, 785mm Working Width. PN:606037



ET4045 / ETB4045 Optional Polyurethane Blade Upgrade Kit 785mm Working Width PN:606074

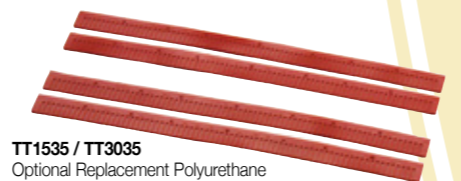

TT1535 / TT3035 Optional Replacement Polyurethane Blade Set (4 pieces) PN:606091



TT4045 / TTB4045 / TTV678 Replacement Polyurethane Blade Set, 805mm Working Width TT4045/TTB4045/CRO8055/TTV678 PN:900518 TT4055/TTB4055/TTB6055/TTV4555 PN:900519 TTB6650/TTV5565/TTV678 PN:900520

## TwinTec / Vario Floor Tools



TT / TTB1840 Parabolic Floor Tool Polyurethane Blade PN:606282



ET4055 / ETB4055 Optional Large Structofoam Floor Tool, Rubber Blade, 845mm Working Width. PN:606310

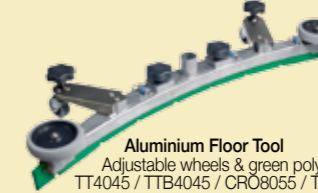

Aluminium Floor Tool Adjustable wheels & green polyurethane blades included TT4045 / TTB4045 / CRO8055 / TTV678 PN:900521 TT4055 / TTB4055 / TTB6055 / TTV4555 PN:900522 TT6650 / TTV5565 / TTV678 PN:900523

## TwinTec / Vario Accessories



All TT/TTB Machines Wander Floor Kit (32mm) (Except TT / TTB1840) PN:607250

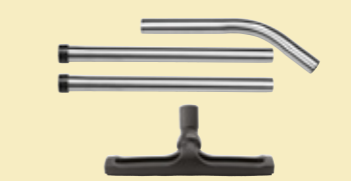

All TTB Machines Wander Floor Kit (38mm), (Except TT / TTB1840) PN:606193



TTV678 38mm Emptying Hose Extension PN:606186



TTV678 Battery LED Front Light Kit PN:606170



Twintec / Vario Aluminium Floor Tool Wide Angle Adjustable Castor Plate Upgrade Kit. PN:606319



Twintec / Vario 38/32mm Hose Adaptor PN:237220



Generic 20m Cable Roll Extension UK PN:612002 20m Cable Roll Extension Euro PN:612003



Twintec / Vario Emptying Hose Extension Kit PN:609100



Twintec / Vario Floor Tool Detent Pin PN:206953



TT / TTB4045 / 4055 Floor Tool Bracket Assembly PN:304466



TT / TTB6055 / TTV4555 / 5565 Floor Tool Bracket Assembly, PN:304479



TRO650 / TTV678 Floor Tool Bracket Assembly. PN:303795



38mm Dosing Tank Cap PN:303827



TTV678 Dosing Tank PN:606169



42mm Dosing Tank Cap PN:304456



TTV USB Preset Locking Key PN:606279



TTV4555 / TTV5565 Dosing Tank PN:606278



TTB1840 Battery & Charger Pack UK PN:606266, EUR PN:606267, CH PN:606268, USA PN:606275, SA PN:606270, AUS PN:606271



TTB1840 Charger Pack UK PN:606272, EUR PN:606273, CH PN:606274, USA PN:606275, SA PN:606276, AUS PN:606277 (Boxed) PN:606260



**Numatic International  
Limited,**

Chard, Somerset,  
TA20 2GB,  
UNITED KINGDOM

Tel: 01460 68600  
Fax: 01460 68458

[www.numatic.co.uk](http://www.numatic.co.uk)



**Numatic International  
S.A.S,**

13/17 rue du Valengelier,  
EAE la Tuilerie,  
77500 Chelles,  
FRANCE

Tel: 01 64 72 61 61  
Fax: 01 64 72 61 62

[www.numatic.fr](http://www.numatic.fr)



**Numatic International  
BV**

BeNeLux Distribution  
Numatic International BV  
Postbus 101  
2400 AC Alphen aan den Rijn  
NEDERLAND

Tel: 0172 467 999  
Fax: 0172 467 970

[www.numatic.nl](http://www.numatic.nl)



**Numatic International  
GMBH**

Fränkische Straße 15-19,  
30455 Hannover  
DEUTSCHLAND

Tel: 05 11 98 42 16 0  
Fax: 05 11 98 42 16 20

[www.numatic.de](http://www.numatic.de)



**Numatic International  
Schweiz AG.**

Sihlbruggstraße 142  
6340 Baar,  
SCHWEIZ

Tel: 041 768 07 60  
Fax: 041 768 07 69

[www.numatic.ch](http://www.numatic.ch)



**Numatic International  
ULDA**

Centro de Negócios da Maia  
Rua Albino José Domingues  
n.º 581 4470 - 034 Maia  
PORTUGAL

Tel: 351 220 047 700

[www.numatic.pt](http://www.numatic.pt)



**Numatic International  
(Pty.) Ltd.**

16th & Pharmaceutical Roads,  
Midrand, Gauteng, S.A. 1685.

Tel: 0861 686 284  
Fax: 0861 686 329

[www.numatic.co.za](http://www.numatic.co.za)

