

ICC-ES Evaluation Report

ESR-2385

Reissued August 2019

This report is subject to renewal August 2021.

www.icc-es.org | (800) 423-6587 | (562) 699-0543

A Subsidiary of the International Code Council®

DIVISION: 07 00 00—THERMAL AND MOISTURE PROTECTION

Section: 07 41 13—Metal Roof Panels

REPORT HOLDER:

METAL SALES MANUFACTURING CORPORATION

EVALUATION SUBJECT:

METAL SALES MANUFACTURING CORPORATION'S STEEL ROOF PANELS

1.0 EVALUATION SCOPE

1.1 Compliance with the following codes:

- 2015, 2012 and 2009 *International Building Code*® (IBC)
- 2015, 2012 and 2009 *International Residential Code*® (IRC)

Properties evaluated:

- Weather resistance
- Fire classification
- Structural
- Wind uplift resistance

1.2 Evaluation to the following green code:

- 2016 California Green Building Standards Code (CALGreen), Title 24, Part 11

Attributes verified:

- See Section 3.1

2.0 USES

The panels are used as roof coverings over solid or closely fitted decking and spaced supports.

3.0 DESCRIPTION

3.1 General:

The panels and the clips used with the panels are cold-formed from steel and/or aluminum conforming to the product specifications, galvalume or zinc coatings, and base-metal thicknesses noted in Tables 1 and 2. See Figures 1 through 13 for panel and clip configurations.

The attributes of the metal roofing panels have been verified as conforming to the provisions of CALGreen Section A5.406.1.2 for reduced maintenance. Note that decisions on compliance for those areas rest with the user of this report. The user is advised of the project-specific

provisions that may be contingent upon meeting specific conditions, and the verification of those conditions is outside the scope of this report. These codes or standards often provide supplemental information as guidance.

3.2 Material:

Solid or closely fitted decking must be a minimum of 1⁵/₃₂-inch-thick (11.9 mm) plywood or lumber sheathing complying with IBC Section 2304.7.2 or IRC Section R803, or minimum No. 22 gauge [0.030 inch thick (0.76 mm)] steel complying with IBC Section 2210.1.1.2.

3.3 Underlayment and Flashing:

Underlayment must be in accordance with IBC Section 1507.4.5, 2015 IRC Sections R905.1.1 and R905.10.5 or 2012 and 2009 IRC Section R905.10.5, as applicable. Where specified in Table 5, the underlayment is VersaShield® Fire-Resistant Roof Deck Protection ([ESR-2053](#)). Flashing must be in accordance with IBC Section 1503.2 or IRC Section R903.2, as applicable.

4.0 DESIGN AND INSTALLATION

4.1 Installation:

Installation of the roof panels and panel clips must be in accordance with this report, IBC Section 1507.4 or IRC Section R905.10, and the manufacturer's published installation instructions. The manufacturer's installation instructions must be available at the jobsite at all times during installation.

The panels must be installed on roofs with a minimum slope as noted in Table 2. Penetrations and terminations of the panels must be flashed and made weathertight in accordance with the manufacturer's published installation instructions and IBC Section 1503.2 or IRC Section R903.2, as applicable.

4.2 Live Loads:

The Magna-Loc, Magna-Loc 180, Clip-Loc, and IC72-Panel, when installed as a three-span condition with spans 5 feet (1.52 m) on center, are capable of withstanding the minimum uniform distributed live load of 20 psf (0.958 kPa) noted in Table 1607.1 of the IBC, and the minimum concentrated live load of 300 lbf (1.33 kN).

When panels are installed over solid or closely fitted deck sheathing, the capacity is limited to the capacity of the sheathing.

4.3 Wind Uplift Resistance:

The allowable wind uplift pressures of the panels are provided in Table 4.

4.4 Fire Classification:

When installed as specified in Table 5, the steel and aluminum roof panels are components of roof assemblies classified as Class A or B roof assemblies in accordance with ASTM E108 or UL 790.

5.0 CONDITIONS OF USE

The Metal Sales Manufacturing Corporation’s roof panels described in this report comply with, or are suitable alternatives to what is specified in, those codes listed in Section 1.0 of this report, subject to the following conditions:

- 5.1 Installation must comply with the applicable code, this report and the manufacturer’s published installation instructions. In the event of conflict between this report and the manufacturer’s instructions, this report governs.
- 5.2 The metal panels must be installed only by applicators approved by Metal Sales Manufacturing Corporation.
- 5.3 Design wind uplift pressure on any roof area, including edge and corner zones, must not exceed the allowable wind pressure for the system installed in that particular area. Refer to the allowable wind uplift pressure for the metal panels as listed in Table 4.
- 5.4 The allowable wind uplift pressures listed in Table 3 are for the roof covering only. The deck and framing to which the roof covering is attached must be designed for the applicable components and cladding

wind loads in accordance with the IBC or IRC, as applicable.

5.5 Calculations demonstrating that the required wind resistance is less than the allowable wind resistance must be submitted to the code official.

5.6 See Table 1 for panel manufacturing locations. The manufacturing is under a quality-control program with inspections by ICC-ES.

6.0 EVIDENCE SUBMITTED

Data in accordance with the ICC-ES Acceptance Criteria for Metal Roof Coverings (AC166), dated October 2012 (editorially revised June 2015).

7.0 IDENTIFICATION

7.1 The panels are identified with a label bearing the product name, the material type, the manufacturer’s name (Metal Sales Manufacturing Corporation), and the evaluation report number (ESR-2385).

7.2 The report holder’s contact information is the following:

METAL SALES MANUFACTURING CORPORATION
545 SOUTH 3RD STREET
LOUISVILLE, KENTUCKY 40202
(800) 406-7387
www.metalsales.us.com
info@metalsales.us.com

TABLE 1—MANUFACTURING FACILITIES AND ASSOCIATED PANEL PROFILES

MANUFACTURING FACILITY	ASSOCIATED PANEL PROFILES
Metal Sales Manufacturing Corporation Woodland, California 95776	Classic Rib R-Panel PBR-Panel 7/8" Corrugated 2.5" Corrugated Image II IC72-Panel Vertical Seam
Metal Sales Manufacturing Corporation Fontana, California 92335	U-Panel PBU-Panel Clip-Loc Vertical Seam Magna-Loc Magna-Loc180

TABLE 2—METAL SALES ROOF PANEL AND CLIP SPECIFICATIONS

PANEL	MINIMUM ROOF SLOPE	MATERIAL			MIN. BASE STEEL THICKNESS (inch)
		Specification	Classification	Coating	
16" Magna-Loc 18" Magna-Loc	¼:12	ASTM A792	SS Grade 50 Class I	AZ50 or AZ55	0.0223 (24 gauge) 0.0293 (22 gauge)
		ASTM A653	SS Grade 33	G60 ¹ or G90	0.0356 (20 gauge)
16" Magna-Loc180 18" Magna-Loc180	¼:12	ASTM A792	SS Grade 50 Class I	AZ50 or AZ55	0.0223 (24 gauge) 0.0293 (22 gauge)
		ASTM A653	SS Grade 50 Class I	G60 ¹ or G90	
16" Vertical Seam	¼:12	ASTM A792	SS Grade 50 Class I	AZ50 or AZ55	0.0171 (26 gauge) 0.0223 (24 gauge)
		ASTM A653	SS Grade 50 Class I	G60 ¹ or G90	
		ASTM B209	3004-H14	NA	0.032
18" Vertical Seam	¼:12	ASTM A792	SS Grade 50 Class I	AZ50 or AZ55	0.0223 (24 gauge)
		ASTM A653	SS Grade 50 Class I	G60 ¹ or G90	
Clip-Loc	¼:12	ASTM A792	SS Grade 50 Class I	AZ50 or AZ55	0.0171 (26 gauge) 0.0223 (24 gauge) 0.0293 (22 gauge)
		ASTM A653	SS Grade 50 Class I	G60 ¹ or G90	
16" Image II	3:12	ASTM A792	SS Grade 50 Class I	AZ50 or AZ55	0.0171 (26 gauge)
		ASTM A653	SS Grade 50 Class I	G60 ¹ or G90	
		ASTM B209	3004-H14	NA	0.032
IC72-Panel	½:12	ASTM A792	SS Grade 50 Class I	AZ50 or AZ55	0.0171 (26 gauge) 0.0223 (24 gauge)
		ASTM A653		G60 ¹ or G90	
7/8" Corrugated	¼:12	ASTM A792	SS Grade 80	AZ50 or AZ55	0.0171 (26 gauge)
		ASTM A653	SS Grade 80	G60 ¹ or G90	
Classic Rib	3:12	ASTM A792	SS Grade 80	AZ50 or AZ55	0.0134 (29 gauge)
		ASTM A653	SS Grade 80	G60 ¹ or G90	0.0134 (29 gauge)
		ASTM B209	3004-H14	NA	0.032
2.5" Corrugated	3:12	ASTM A792	SS Grade 50 Class I	AZ50 or AZ55	0.0171 (26 gauge)
		ASTM A653	SS Grade 50 Class I	G60 ¹ or G90	
R-Panel / PBR-Panel U-Panel / PBU-Panel	½:12	ASTM A792	SS Grade 80	AZ50 or AZ55	0.0171 (26 gauge)

For SI: 1 inch = 25.4 mm.

¹The G60 coating is only applicable to Group U buildings per IBC Table 1507.4.3 (1).

TABLE 3—METAL SALES CLIP SPECIFICATIONS

CLIP	MATERIAL			MIN. BASE STEEL THICKNESS (inch)	See Figure
	Specification	Classification	Coating		
Magna-Loc Clip	Tab – ASTM A653 Base – ASTM A653	Tab - Grade 50 Base – Grade 50	Tab – G90 Base – G60	Tab – 0.031 Base – 0.064	1B & 2B
Vertical Seam Clip	ASTM A653	Grade 50	G90	0.050	3B
Clip-Loc Clip	ASTM A653	Grade 36 min	G90	0.030	4B

For SI: 1 inch = 25.4 mm.

TABLE 4—ALLOWABLE WIND UPLIFT PRESSURES

PANEL	SUPPORT	FASTENING PATTERN ¹	SPAN ² (inch)	ALLOWABLE UPLIFT PRESSURE (psf)
16" Magna-Loc (24 gauge steel)	¹⁹ / ₃₂ " Plywood	Magna-Loc Clips with (2) ATLAS #12-11 x 1.5" long low profile pancake head wood screws (See Figure 1)	30	80
			24	90
			18	100
			12	115
			8	125
16" Magna-Loc (24 gauge steel)	Min. 30 mil Steel Steel Deck ²	MC Clips with (2) TRUFAST #14-13 x 6" long pancake head screws through bearing plate and rigid insulation. Bearing plates are 4" x 5" x 20 gauge (See Figure 1)	48	55
			42	70
			36	85
			30	100
			24	110
			18	120
			8	130
16" Magna-Loc (24 gauge steel)	Min. 54 mil Steel Spaced Supports	Magna-Loc Clips with (2) ATLAS ¹ / ₄ "-14 x 1.5" long hex head self-drilling screws (See Figure 1)	60	40
			54	50
			48	60
			42	70
			36	75
			30	85
			24	90
16" Magna-Loc (22 gauge steel)	Min. 54 mil Steel Spaced Supports	Magna-Loc Clips with (2) ATLAS ¹ / ₄ "-14 x 1.5" long hex head self-drilling screws (See Figure 1)	60	65
			54	70
			48	75
			42	80
			36	85
			30	90
			24	100
16" Magna-Loc (20 gauge steel)	Min. 54 mil Steel Spaced Supports	Magna-Loc Clips with (2) ATLAS ¹ / ₄ "-14 x 1.5" long hex head self-drilling screws (See Figure 1)	60	55
			54	65
			48	80
			42	90
			36	100
			30	115
			24	125
18" Magna-Loc (24 gauge steel)	Min. 54 mil Steel Spaced Supports	Magna-Loc Clips with (2) ATLAS ¹ / ₄ "-14 x 1.5" long hex head self-drilling screws (See Figure 1)	60	40
			54	50
			48	60
			42	70
			36	80
			30	90
			24	100
18" Magna-Loc (22 gauge steel)	Min. 54 mil Steel Spaced Supports	Magna-Loc Clips with (2) ATLAS ¹ / ₄ "-14 x 1.5" long hex head self-drilling screws (See Figure 1)	60	40
			54	50
			48	55
			42	65
			36	75
			30	80
			24	90
18" Magna-Loc (20 gauge steel)	Min. 54 mil Steel Spaced Supports	Magna-Loc Clips with (2) ATLAS ¹ / ₄ "-14 x 1.5" long hex head self-drilling screws (See Figure 1)	60	45
			54	60
			48	70
			42	85
			36	95
			30	110
			24	120

TABLE 4—ALLOWABLE WIND UPLIFT PRESSURES (Continued)

PANEL	SUPPORT	FASTENING PATTERN ¹	SPAN ² (inch)	ALLOWABLE UPLIFT PRESSURE (psf)			
16" Magna-Loc 180 (24 gauge steel)	Min. 54 mil Steel Spaced Supports	Magna-Loc Clips with (2) SFS 1/4"-14 x 1.5" long hex head self-drilling screws (See Figure 2)	60	30			
			54	40			
			48	45			
			42	50			
			36	60			
			30	65			
			24	70			
16" Magna-Loc 180 (22 gauge steel)	Min. 54 mil Steel Spaced Supports	Magna-Loc Clips with (2) ATLAS 1/4"-14 x 1.5" long hex head self-drilling screws (See Figure 2)	60	60			
			54	75			
			48	90			
			42	100			
			36	115			
			30	130			
			24	140			
18" Magna-Loc 180 (24 gauge steel)	Min. 54 mil Steel Spaced Supports	Magna-Loc Clips with (2) ATLAS 1/4"-14 x 1.5" long hex head self-drilling screws (See Figure 2)	60	40			
			54	50			
			48	60			
			42	70			
			36	80			
			30	90			
			24	100			
18" Magna-Loc 180 (22 gauge steel)	Min. 54 mil Steel Spaced Supports	Magna-Loc Clips with (2) ATLAS 1/4"-14 x 1.5" long hex head self-drilling screws (See Figure 2)	60	55			
			54	70			
			48	80			
			42	90			
			36	105			
			30	115			
			24	125			
16" Vertical Seam (26 gauge steel)	15/32" Plywood	Vertical Seam Clips with (2) ATLAS #10-12 x 1" long pancake head wood screws (See Figure 3)	48	35			
			42	45			
			36	50			
			30	55			
			24	60			
			18	70			
			12	75			
6	80						
16" Vertical Seam (24 gauge steel)	15/32" Plywood	Vertical Seam Clips with (2) ATLAS #10-12 x 1" long pancake head wood screws (See Figure 3)	24	75			
			20	85			
			16	95			
			12	105			
			8	115			
			18" Vertical Seam (24 gauge steel)	15/32" Plywood	Vertical Seam Clips with (2) ATLAS #10-12 x 1" long pancake head wood screws (See Figure 3)	48	30
						42	40
36	50						
30	55						
24	65						
18	70						
12	85						
16" Vertical Seam (0.032" Aluminum)	7/16" OSB	Vertical Seam Clips with (2) ATLAS #10-12 x 2" long pancake head wood screws (See Figure 3)	36	40			
			30	50			
			24	55			
			18	65			
			12	70			

TABLE 4—ALLOWABLE WIND UPLIFT PRESSURES (Continued)

PANEL	SUPPORT	FASTENING PATTERN ¹	SPAN ² (inch)	ALLOWABLE UPLIFT PRESSURE (psf)
Clip-Loc (26 gauge steel)	Min. 54 mil Steel Spaced Supports	Clip-Loc Clip with (2) SFS #10-16 x 1" long pancake head self-drilling screws. (See Figure 4)	60	30
			54	35
			48	35
			42	40
			36	40
			30	40
			24	40
Clip-Loc (24 gauge steel)	Min. 54 mil Steel Spaced Supports	Clip-Loc Clip with (2) SFS #10-16 x 1" long pancake self-drilling screws. (See Figure 4)	60	25
			54	30
			48	35
			42	40
			36	45
			30	50
			24	55
Clip-Loc (22 gauge steel)	Min. 54 mil Steel Spaced Supports	Clip-Loc Clip with (2) SFS #10-16 x 1" long pancake self-drilling screws. (See Figure 4)	60	25
			54	35
			48	40
			42	50
			36	55
			30	60
			24	70
16" Image II (0.032" Aluminum)	7/16" OSB	ATLAS #10-12 x 2" long pancake head wood screws along the panel sidelap. (See Figure 5)	24	25
			21	40
			18	50
			15	65
			12	80
			9	95
			6	110
16" Image II (26 gauge steel)	7/16" OSB	ATLAS #10-12 x 2" long pancake head wood screws along the panel sidelap. (See Figure 5)	24	20
			21	30
			18	35
			15	40
			12	50
			9	55
			6	65
IC72-Panel (26 gauge steel)	Min. 54 mil Steel Spaced Supports	ATLAS #12-14 x 1.25" long hex head self-drilling screws at 14.4" o.c. across the panel width at all supports. Sidelap fasteners are ATLAS 1/4"-14 x 7/8" long hex head self-drilling screws at 12" o.c. (See Figure 6)	60	50
			54	55
			48	60
			42	70
			36	75
			30	85
			24	90
IC72-Panel (24 gauge steel)	Min. 54 mil Steel Spaced Supports	ATLAS #12-14 x 1.25" long hex head self-drilling screws at 14.4" o.c. across the panel width at all supports. Sidelap fasteners are ATLAS 1/4"-14 x 7/8" long hex head self-drilling screws at 12" o.c. (See Figure 6)	60	55
			54	65
			48	75
			42	85
			36	100
			30	110
			24	120
IC72-Panel (24 gauge steel)	Min. 54 mil Steel Spaced Supports	ATLAS #12-14 x 1.25" long hex head self-drilling screws at 7.2" o.c. across the panel width at all supports. Sidelap fasteners are ATLAS 1/4"-14 x 7/8" long hex head self-drilling screws at 12" o.c. (See Figure 6)	60	75
			54	90
			48	110
			42	125
			36	140
			30	160
			24	175

TABLE 4—ALLOWABLE WIND UPLIFT PRESSURES (Continued)

PANEL	SUPPORT	FASTENING PATTERN ⁽¹⁾	SPAN ² (inch)	ALLOWABLE UPLIFT PRESSURE (psf)
7/8" Corrugated (26 gauge steel)	15/32" Plywood	ATLAS #9-16 x 1.5" long or #10-14 x 1.5" long hex head wood screws with sealed washer @ 8" o.c. across panel width (every third ridge) (See Figure 7)	60	30
			54	40
			48	45
			42	50
			36	60
			30	65
			24	70
			18	80
			12	85
Classic Rib (0.032" Aluminum)	7/16" OSB	ATLAS #9-16 x 1.5" long or #10-14 x 1.5" long hex head wood screws with sealed washer @ 9" o.c. across panel width with two fasteners at each sidelap. Sidelap fasteners (optional) are ATLAS 1/4"-14 x 7/8" long self-drilling screws @ 12" o.c. (See Figure 8)	36	30
			30	50
			24	65
			18	85
			12	100
			6	120
Classic Rib (29 gauge steel)	15/32" Plywood	ATLAS #9-16 x 1.5" long or #10-14 x 1.5" long hex head wood screws with sealed washer @ 9" o.c. across panel width with two fasteners at each sidelap. Sidelap fasteners (optional) are ATLAS 1/4"-14 x 7/8" long self-drilling screws @ 12" o.c. (See Figure 8)	24	70
			21	85
			18	105
			15	120
			12	140
2.5" Corrugated (26 gauge steel)	19/32" Plywood	ATLAS #9-16 x 1.5" long or #10-14 x 1.5" long hex head wood screws with sealed washer @ 5.33" o.c. across panel width (every other valley). Sidelap fasteners are ATLAS 1/4"-14 x 7/8" long hex head self-drilling screws @ 18" o.c. (See Figure 9)	36	85
			30	90
			24	90
			18	90
			12	95
U-Panel/PBU-Panel (26 gauge steel)	15/32" Plywood	ATLAS #9-16 x 1.5" long or #10-14 x 1.5" long hex head wood screws with sealed washer @ 6" o.c. across panel width. Sidelap fasteners are ATLAS 1/4"-14 x 7/8" long hex head self-drilling screws @ 12" o.c. (See Figures 10 & 11)	48	30
			42	45
			36	55
			30	70
			24	80
			18	95
			12	110
R-Panel/PBR-Panel (26 gauge steel)	15/32" Plywood	ATLAS #9-16 x 1.5" long or #10-14 x 1.5" long hex head wood screws with sealed washer @ 12" o.c. across panel width. Sidelap fasteners are ATLAS 1/4"-14 x 7/8" long hex head self-drilling screws @ 12" o.c. (See Figures 12 & 13)	48	30
			42	45
			36	60
			30	75
			24	90
			18	100
			6	130

For SI: 1 inch = 25.4 mm, 1 psf = 0.0479 kPa.

¹Fastener must be of sufficient length to penetrate through the support a minimum of 3/4 inch.

²Span indicates fastener or clip spacing along panel length.

TABLE 5—FIRE CLASSIFICATION ASSEMBLIES

ROOF CLASS	SUBSTRATE ¹	MAX. ROOF SLOPE	ASSEMBLY DETAIL ²	
A	Noncombustible	Unlimited	Panels:	20, 22, & 24 gauge, 16" Magna-Loc 20, 22, & 24 gauge, 18" Magna-Loc 22 & 24 gauge, 16" Magna-Loc 180 22 & 24 gauge, 18" Magna-Loc 180 22, 24 & 26 gauge, Clip-Loc 24 & 26 gauge, IC72-Panel (All panels are steel)
A	Combustible	Unlimited	Underlayment:	One Layer of VersaShield® Fire-Resistant Roof Deck Protection
			Panels:	24 gauge, 16" Magna-Loc 24 & 26 gauge, 16" Vertical Seam 24 gauge, 18" Vertical Seam 26 gauge, 16" Image II 26 gauge, 7/8" Corrugated 29 gauge, Classic Rib 26 gauge, 2.5" Corrugated 26 gauge, U-Panel/PBU Panel 26 gauge, R-Panel/PBR Panel (All panels are steel)
A	Combustible	Unlimited	Underlayment:	Two Layers of VersaShield® Fire-Resistant Roof Deck Protection
			Panels:	0.032" thick, 16" Vertical Seam 0.032" thick, 16" Image II 0.032" thick, Classic Rib (All panels are aluminum)
B	Combustible	Unlimited	Underlayment:	One Layer of VersaShield® Fire-Resistant Roof Deck Protection
			Panels:	0.032" thick, 16" Vertical Seam 0.032" thick, 16" Image II 0.032" thick, Classic Rib (All panels are aluminum)

¹Wood deck must be a minimum of 15/32-inch-thick (11.9 mm) plywood.

²GAF's VersaShield® Fire-Resistant Roof Deck Protection is recognized in ICC-ES evaluation report ESR-2053 and must be installed in accordance with that report.

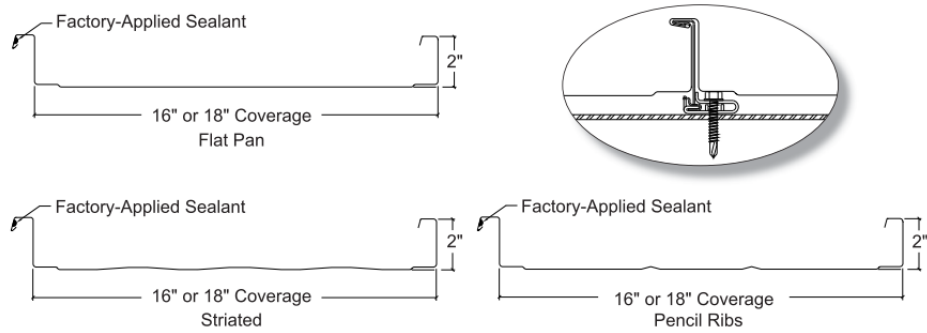

FIGURE 1A—MAGNA-LOC

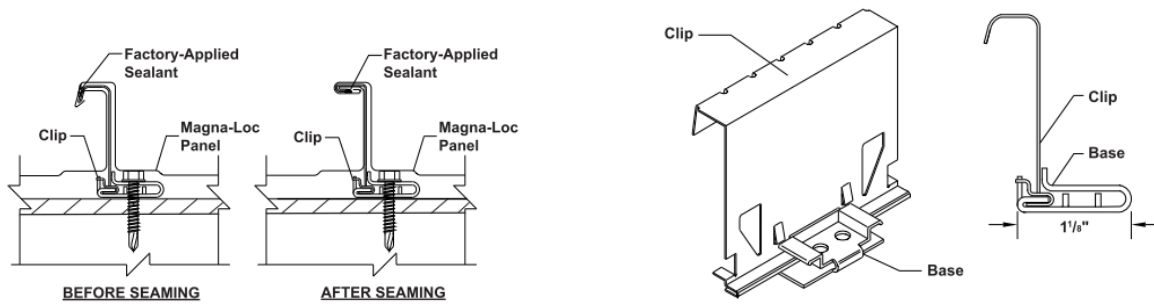

FIGURE 1B—MAGNA-LOC CLIP

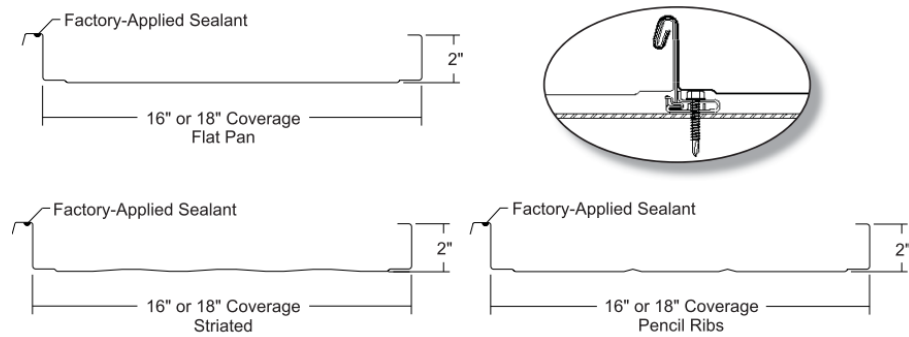

FIGURE 2A—MAGNA-LOC 180

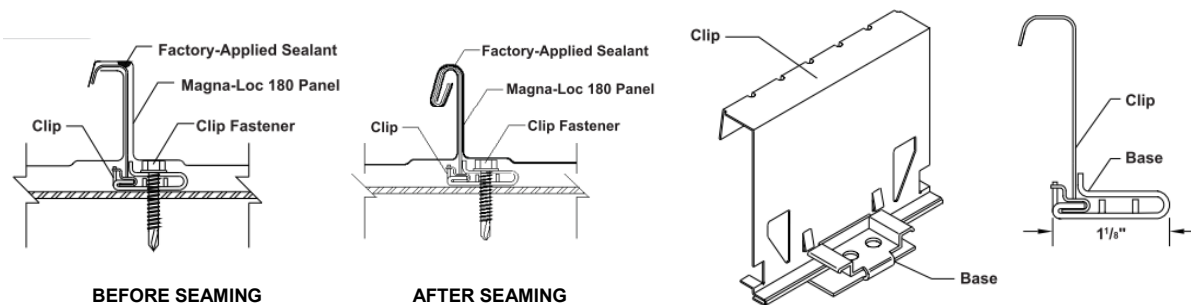

FIGURE 2B—MAGNA-LOC CLIP

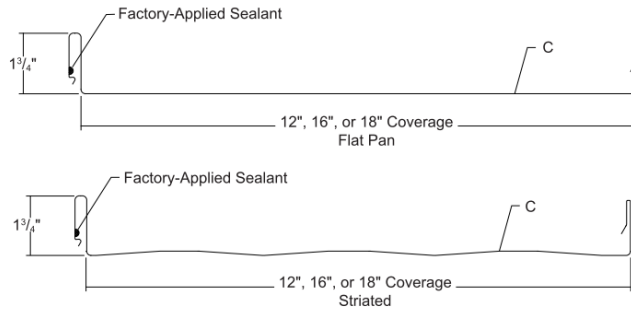

FIGURE 3A—VERTICAL SEAM

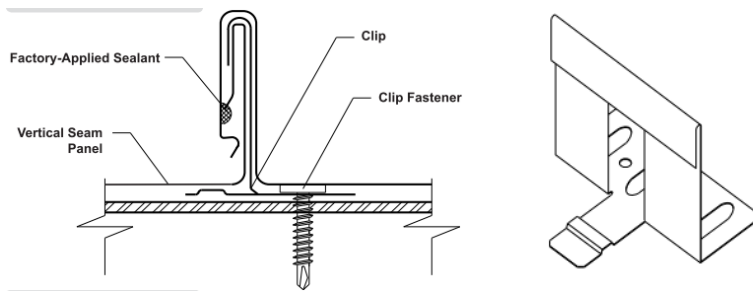

FIGURE 3B—VERTICAL SEAM CLIP

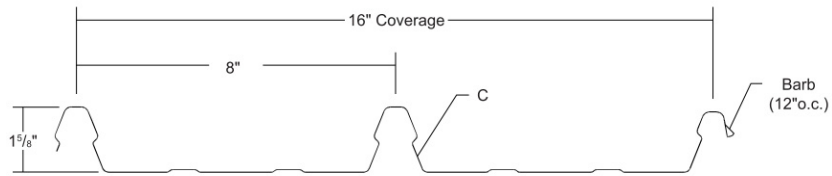

FIGURE 4A—CLIP-LOC

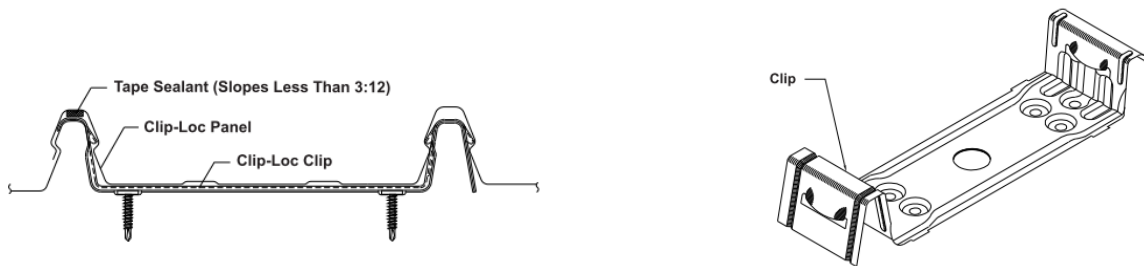

FIGURE 4B—CLIP-LOC CLIP

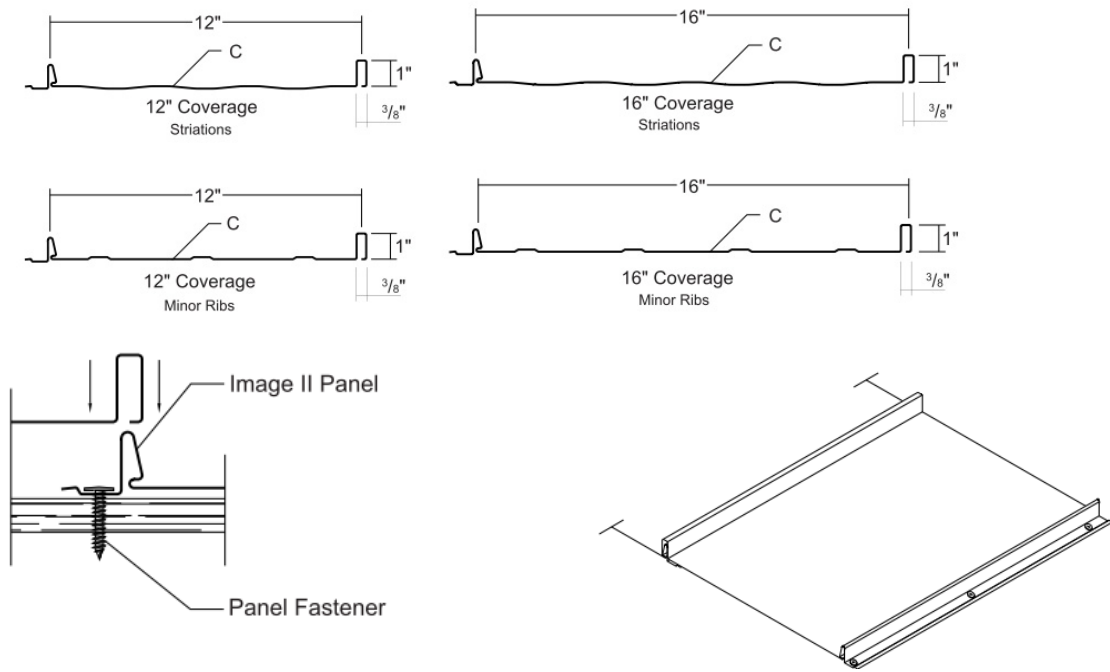

FIGURE 5—IMAGE II

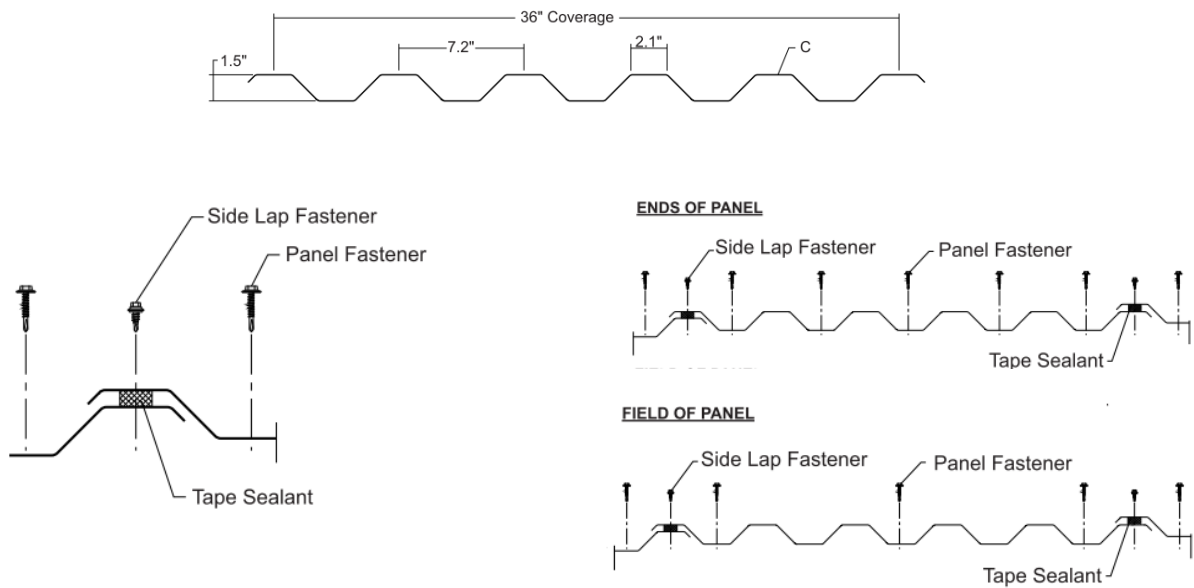

FIGURE 6—IC72 PANEL

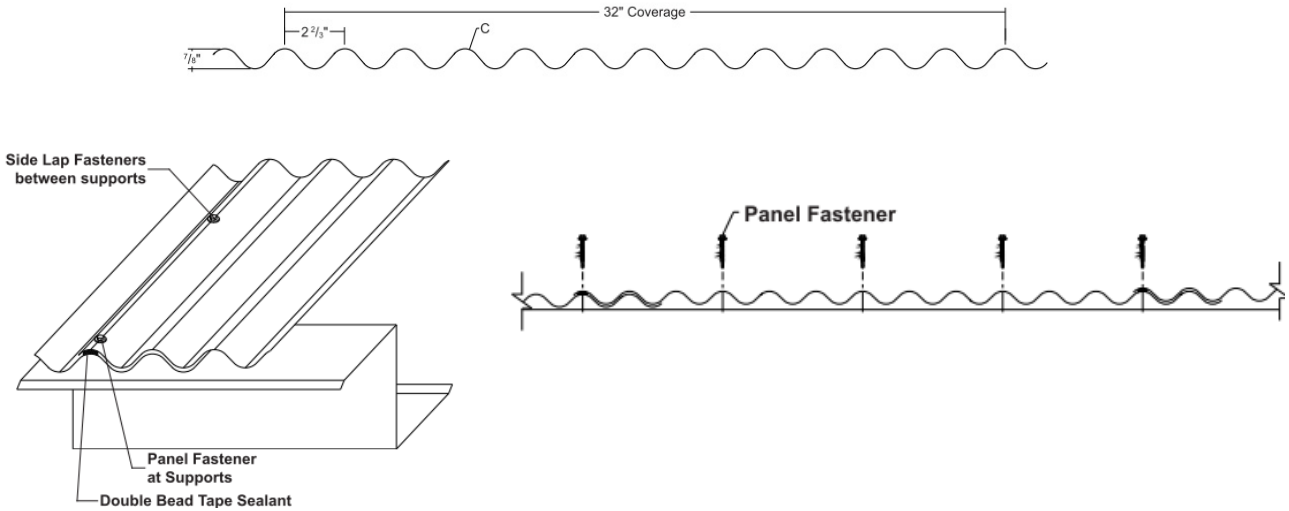

FIGURE 7—7/8" CORRUGATED

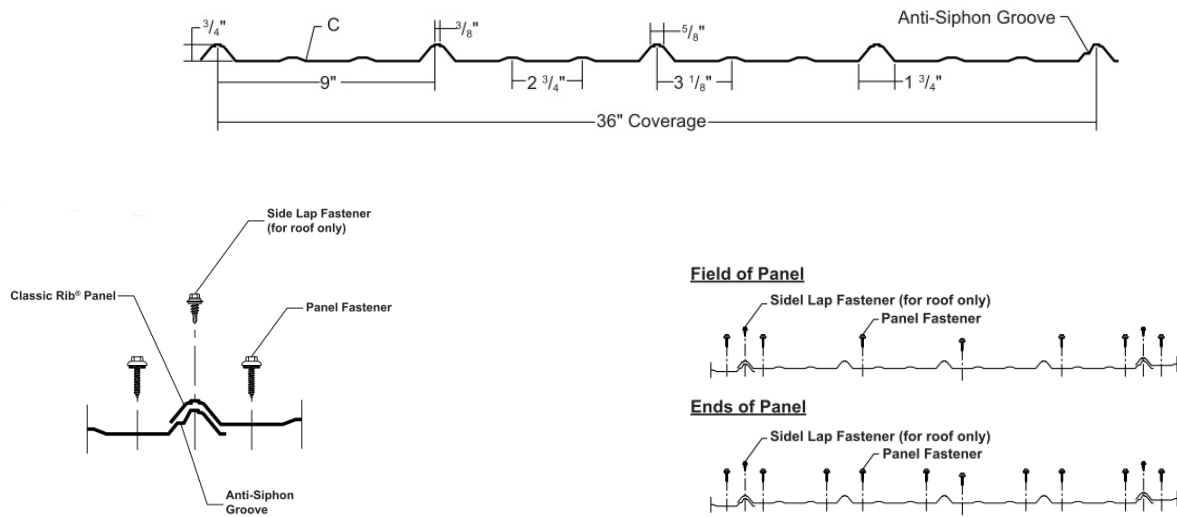

FIGURE 8—CLASSIC RIB

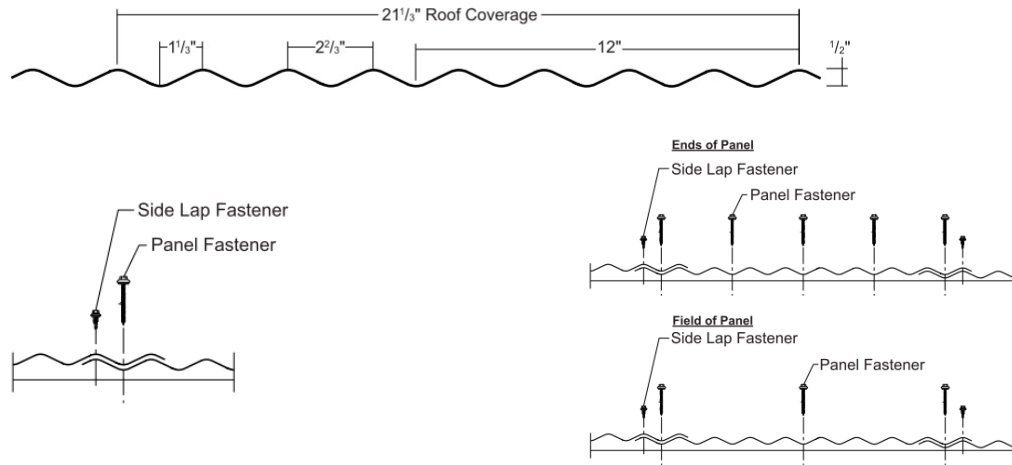

FIGURE 9—2.5" CORRUGATED

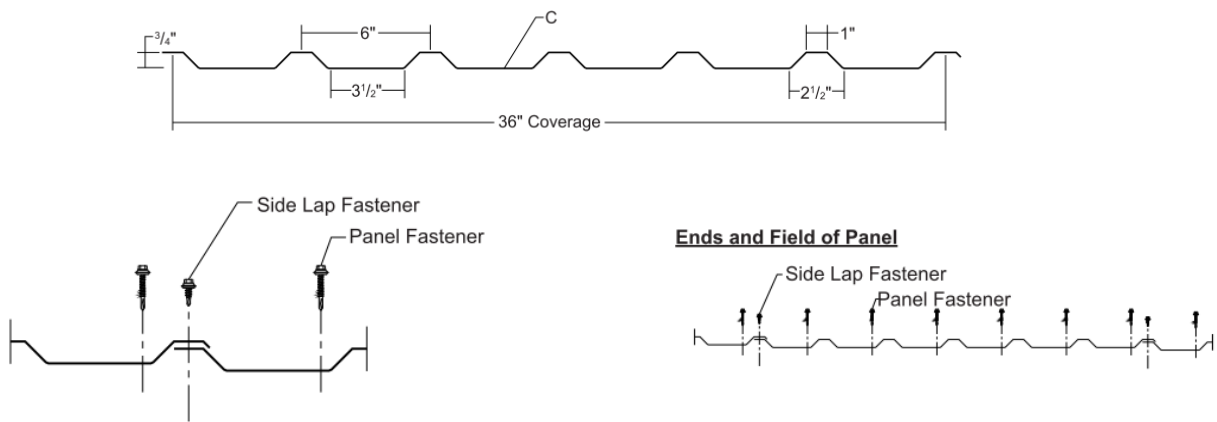

FIGURE 10—U-PANEL

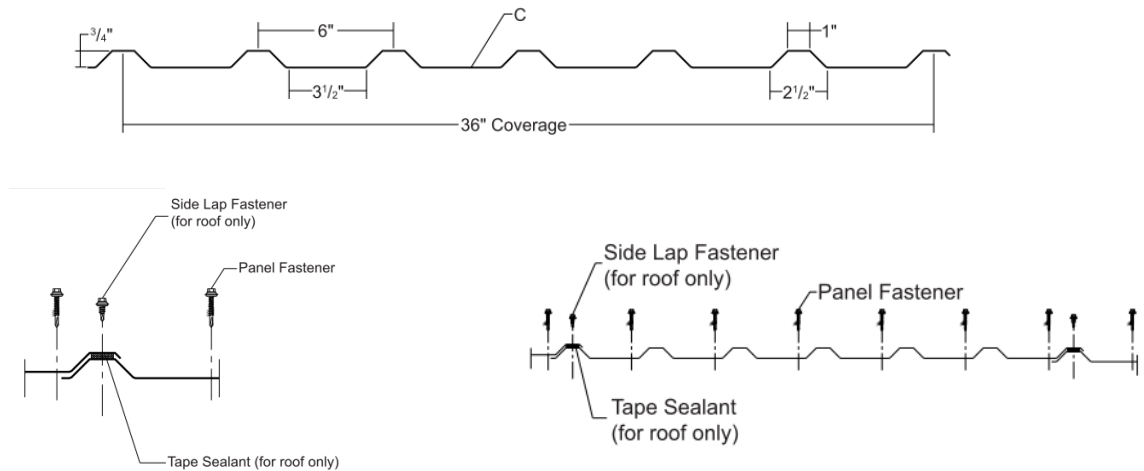

FIGURE 11—PBU-PANEL

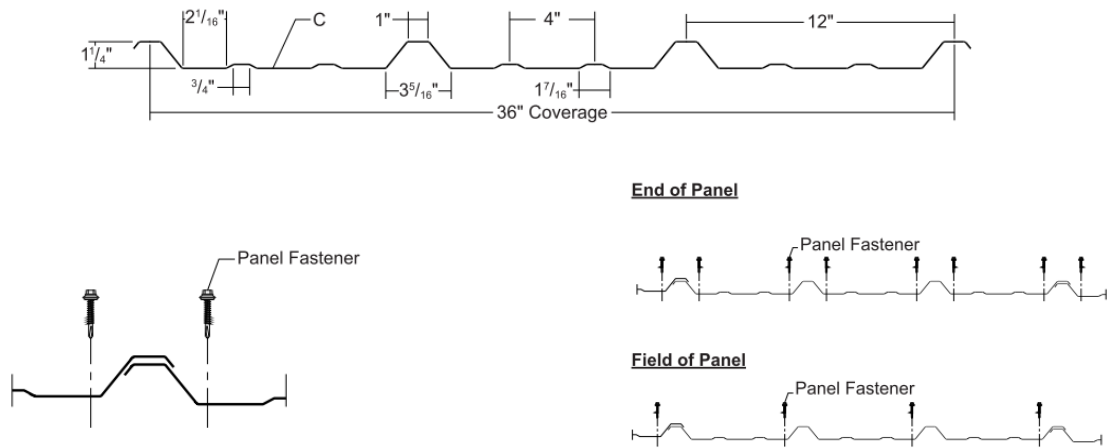

FIGURE 12—R-PANEL

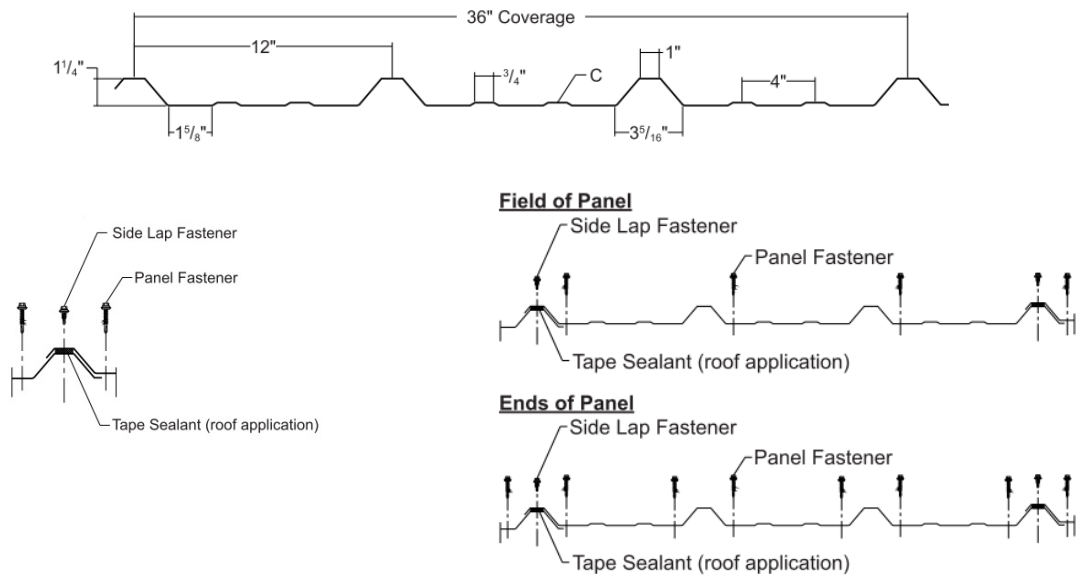

FIGURE 13—PBR-PANEL

ICC-ES Evaluation Report

ESR-2385 CBC and CRC Supplement

Reissued August 2019

This report is subject to renewal August 2021.

www.icc-es.org | (800) 423-6587 | (562) 699-0543 A Subsidiary of the International Code Council®

DIVISION: 07 00 00—THERMAL AND MOISTURE PROTECTION
Section: 07 41 13—Metal Roof Panels

REPORT HOLDER:

METAL SALES MANUFACTURING CORPORATION

EVALUATION SUBJECT:

METAL SALES MANUFACTURING CORPORATION'S STEEL ROOF PANELS

1.0 REPORT PURPOSE AND SCOPE

Purpose:

The purpose of this evaluation report supplement is to indicate that Metal Sales Manufacturing Corporation's Steel Roof Panels, recognized in ICC-ES master evaluation report ESR-2385, have also been evaluated for compliance with the codes noted below.

Applicable code editions:

- 2016 *California Building Code* (CBC)
- 2016 *California Residential Code* (CRC)

2.0 CONCLUSIONS

2.1 CBC:

The Metal Sales Manufacturing Corporation's Steel Roof Panels described in the master evaluation report ESR-2385 may be used where the CBC requires a Class A roof covering complying with CBC Section 1505.1.1, a Class B roof covering complying with CBC Section 1505.1.2, or a Class C roof covering complying with CBC Section 1505.1.3, provided the design and installation are in accordance with the 2015 *International Building Code*® (IBC) provisions noted in the master report, as applicable.

The roofing panels may be used in the construction of new buildings located in any Fire Hazard Zone within State Responsibility Areas or any Wildland–Urban Interface Fire Area, provided installation is in accordance with the 2015 *International Building Code*® (IBC) provisions noted in the master report and the additional requirements of Sections 701A.3 and 705A of the CBC.

2.2 CRC

The Metal Sales Manufacturing Corporation's Steel Roof Panels described in master report ESR-2385 may be used where the CRC requires a Class A roof covering complying with CRC Section R902.1.1, a Class B roof covering complying with CRC Section R902.1.2, or a Class C roof covering complying with CRC Section R902.1.3, provided the design installation is in accordance with the 2015 *International Residential Code*® (IRC) provisions noted in the master report and the additional requirements of Section R905.10 of the CRC.

The roofing panels may be used in the construction of new buildings located in any Fire-Hazard Severity Zone within State Responsibility Areas or Wildland–Urban Interface Fire Area, provided installation is in accordance with the master report and the additional requirements of Sections R337.1.3.1 and R337.5 of the CRC.

The products recognized in this supplement have not been evaluated for compliance with the *International Wildland–Urban Interface Code*®.

This supplement expires concurrently with the master report, reissued August 2019.