



The DALI Guide



This guide has been written to explain DALI and DSI to those who are more familiar with DMX. While DMX, DALI and DSI are all digital protocols, there are some fundamental differences between them that can cause confusion. The guide was prepared in conjunction with the training days Artistic Licence offers to the industry.

As the Architectural, Entertainment & Commercial Lighting industries continue to merge, a knowledge gap has appeared for those who work in these sectors.

The guide will start at the beginning of DSI and DALI. It will explain the evolution of the two protocols, how they work and how to use them. It will also cover DMX / DALI conversion, detailing the common pitfalls and how to avoid them.

At the back of this guide there is an overview of terms and expressions used in DALI.

While the information contained in this guide is provided in good faith and is believed to be correct, no responsibility for its accuracy is accepted by the author or by Artistic Licence Engineering Ltd.

The rights and ownership of all Trademarks are acknowledged.

Copyright © Artistic Licence Engineering Ltd. All rights reserved.

Download the guide by scanning the following QR code:



Contents

The History of DSI & DALI.....	4
Why DALI?.....	4
Overview of a DALI System.....	4
Typical Applications.....	5
Physical Connections.....	5
DALI Topology.....	5
Cable Type.....	5
Polarity.....	6
DALI Bus PSU.....	6
Electrical Signals.....	7
Data Structure.....	7
Commissioning.....	7
DALI Commissioning Tools.....	8
Dali-Scope.....	8
Tridonic USB DALI Interface/Programmer.....	8
DALI Commands.....	8
DMX and DALI as Partners.....	10
DMX to DALI Conversion.....	10
DMXtoDALI quad.....	10
DALI to DMX Conversion.....	10
DALItoDMX.....	10
Dimming Curves.....	11
Glossary of Terms.....	11
DALI Specification.....	12
Appendix - LSi Help Desk articles.....	13

The History of DALI & DSI

In the 1980s there was a strong requirement to make commercial lighting more controllable so that it could become more energy efficient. Initially this was done with analogue control, allowing fluorescent ballasts to be controlled from a central source. This was a step in the right direction, but cabling was complicated and therefore not cost effective.

Tridonic was the first company to go digital with their broadcast protocol, DSI, in 1991. DSI was a basic protocol as it transmitted one control value to change the brightness of all the fixtures attached to the line. What made this protocol more attractive, and able to compete with the established analogue option, was the simple wiring.

A DSI circuit requires only two wires and the fixtures are connected serially, reducing the amount of cabling compared to analogue. In addition the specification of the cable was relatively low tech (compared to DMX) and even the polarity was not an issue. This allowed people with no formal training in DSI to do the installation and achieve a controllable system.

This satisfied the initial requirement of central control that was also cost effective. However, as the protocol was owned by Tridonic, other companies were unwilling to use it. Another limitation was the lack of individual control.

In the late 1990s a controls group, DALI-ag, was set up to design an industry-wide open digital protocol for the commercial lighting market. The members of this working group were made up of people from companies such as Osram, Tridonic and other leaders in the commercial lighting world.

The requirements were:

1. Low cost, simple wiring
2. Individual Control
3. Feedback from the fixtures
4. Ability to add sensors and other proprietary equipment

DALI was released in 2001 and became widely adopted. Since then, its popularity has increased and it is now used in more than just commercial lighting - so much so that it is becoming commonplace to have DMX and DALI systems integrated for centralised control.

Visit www.DALI-ag.org for more details regarding the DALI working group.

As DSI and DALI are very similar, this guide will concentrate mainly on the DALI protocol. The physical system can be considered the same, but the data differs as DSI can only transmit broadcast values.

Why DALI?

DALI was created to provide central control over fixtures, enabling commercial lighting to become more efficient. While the initial development focused on fluorescent ballasts, applications now encompass a range of devices such as LED drivers, HID and low-voltage halogen.

Also, it's not just lighting - for example, the Artistic Licence [daliSwitch](#) product is a DALI controlled 6-channel mains relay. In the future, we can expect to see rotaries, light sensors and more.

DALI stands for Digital Addressable Lighting Interface. It is technically managed under IEC 62386.

Overview of a DALI System

There are four main components required for a DALI subnet (a subnet or circuit is the DALI equivalent of a DMX universe).

1. A DALI controller (may be a gateway, hub or router)
2. A DALI Bus Power Supply
3. Some kind of DALI device
4. Cabling

The system in Figure 1 can be considered one subnet of DALI.

- A DALI subnet can have up to 64 DALI devices/ballasts

- A DALI Bus PSU must always be present on each DALI subnet
- Each device has a short address (0 to 63)
- There should be no duplicate short addresses
- Each device can be assigned to any of the 16 groups
- Each device can have 16 scenes programmed into its memory

There are a number of limitations to DALI that restrict its applications:

- Slow speed
- Relatively low number of devices on a subnet
- Type of DALI equipment on the market

Physical Connections

In terms of cabling and topology, there are distinct differences between DMX and DALI.

Figure 1: Basic DALI System

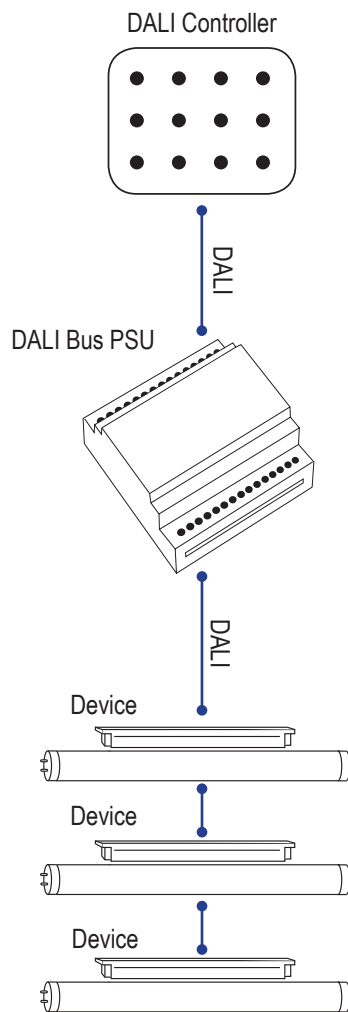

DALI Topology

While DMX is cabled on a strict daisy chain system, DALI is a simple bus that can go in different directions and split into branches. DSI has the same physical connections as DALI.

DALI allows many different kinds of cabling schemes, although for traceability it is always recommended that a logical approach is taken. Below are two example of cabling approaches that can be used ("D" represents Device).

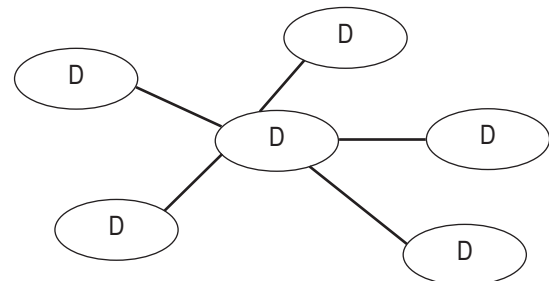

Star Connections

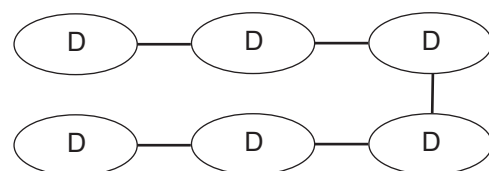

Serial Type

Typical Applications

DALI can be used in any environment that requires central control over lighting fixtures. The most common applications are:

- Commercial office lighting
- House lighting in theatres
- Public building lighting (such as hospitals, airports etc.)

Cable Type

Standard 2-core cable of minimum gauge 1.5 mm² is recommended. The total cabling distance should be limited to 300 m.

The total device current consumption should not exceed 250 mA. The voltage drop must not exceed 2V anywhere on the system.

To minimise voltage drop on the cable, the DALI Bus PSU can be installed at the middle of the system so the cable is split into two equal lengths (see Figure 2).

Polarity

DALI specifies polarity-free installation. This makes installation easier because the control cables do not need any kind of identification (the two cores can be put into any terminal). On the majority of equipment the terminals are identified with the same text.

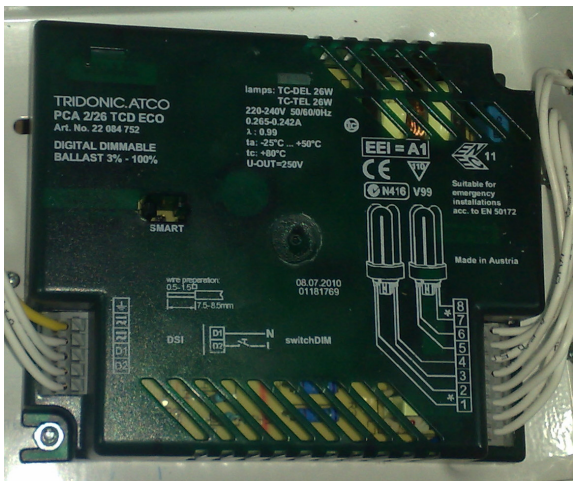

DALI Bus PSU

In the DALI specification, power and data are carried on the same pair of wires.

Electrically, the voltage on the line is toggled at high speed between low (logic level '0') and high (logic level '1') to achieve data communication.

Unlike DMX, the DALI controller does not have to provide the voltage on the line, so an external DALI Bus PSU is generally required (unless the controller has an integrated PSU). Artistic Licence offers Rail-PSU-D4, a four-circuit power supply. The DALI specification requires that the DALI PSU should provide a voltage of 16V and is current-limited at 250mA.

Figure 2: Comparison of DMX and DALI systems

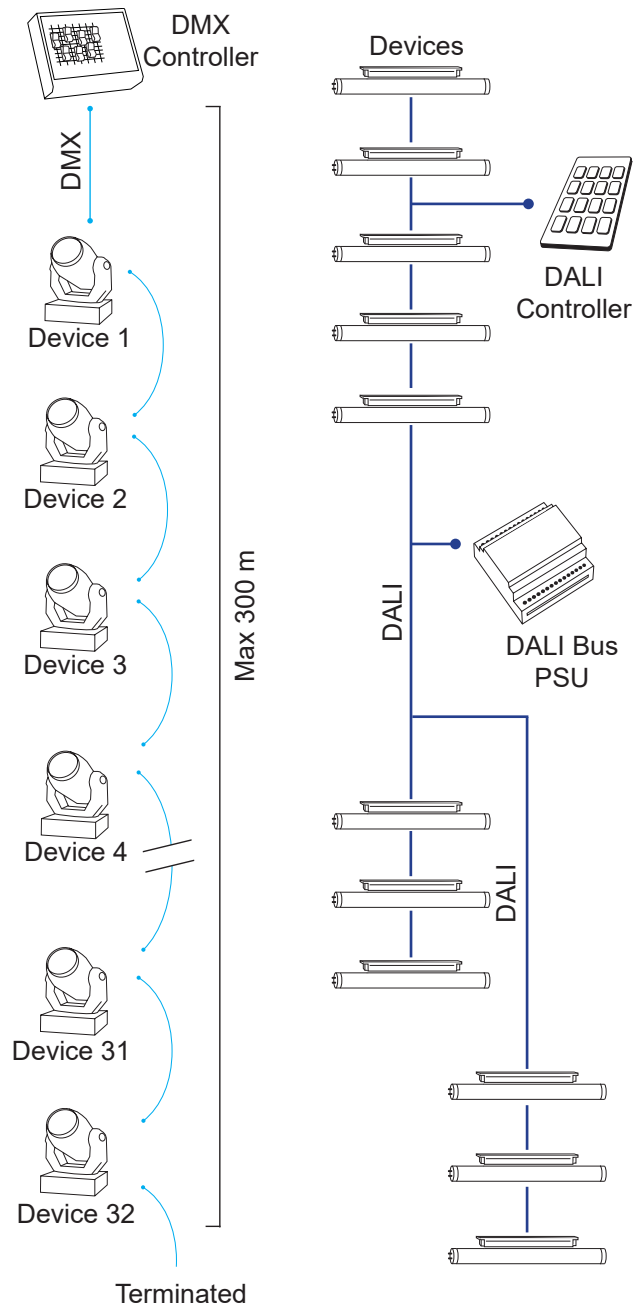

To achieve the logic levels of '0' and '1' the transmitting device (controller or fixture) will short the DALI lines together creating a logic low level – '0'. When it is not shorted the logic level will be high – '1'. This is one of the reasons why the PSU needs to be limited to 250 mA.

The main reasons why DALI is arranged in this manner are:

1. It allows greater flexibility in the wiring of the system as the PSU can be at the centre of the subnet to minimise voltage drop. It might not be possible to put the controller at the centre.

2. The arrangement can reduce voltage drop.
3. Sensors can be powered from the DALI line.

Without the power supply, there is no communication as the DALI devices interpret this as a fault condition and go into a fault state.

Electrical Signals

To achieve the flexibility in the wiring

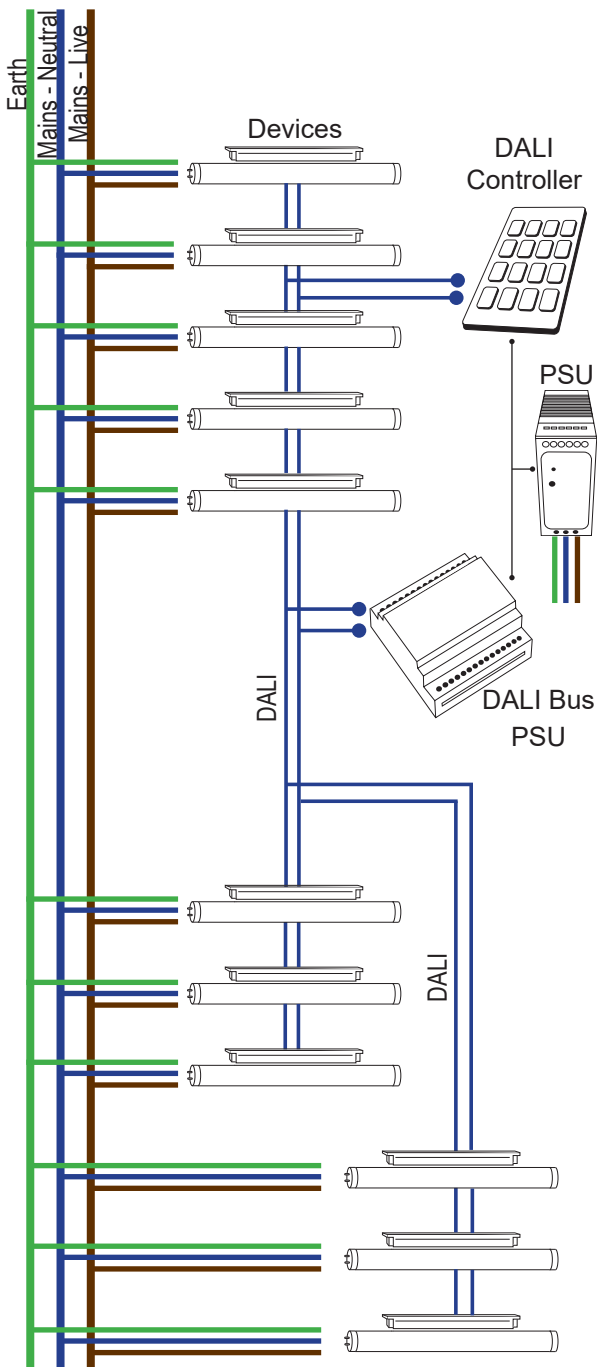

Figure 3: Complete DALI system with electrical wiring

specification, the voltage used for communication needs to be higher than other protocols to compensate for the voltage drop that might occur.

The DALI specification states;

- High Logic Value shall be 16V (9.5V to 22.5V DC)
- Low Logic Value shall be 0V (-4.5V to +4.5V DC)
- A 2V difference is allowed between PSU and end of cable
- The nominal voltage is 16V

Data Structure

DALI is a serial protocol based on Manchester Coding. It has a baud rate of 1,200 bits per second (in comparison, DMX has a baud rate of 250,000 bits per second).

A DALI controller can send different commands to a fixture and therefore needs a different method to DMX to achieve this. Below is the simplified packet that DALI uses.

Address (who)	Command (what)	Data (how much)
---------------	----------------	-----------------

A DALI controller will send a packet for every change it needs to make. The first part of the packet is the short address of the fixture, unless it is broadcasting its message. The second part is the type of command and finally the third part is the value (this is not always needed).

This allows the controller to send a vast number of different commands - such as level, discovery and queries - to a device using the same structure.

Commissioning

All DALI devices need to be commissioned for the first time before they will work correctly. This requires specialised equipment, such as Dali-Scope (see below).

Commissioning involves giving every DALI device a unique short address. This is to

allow two-way communication between the controller and devices.

DALI devices contain a random number generator that enables them to be individually discovered during commissioning. After the commissioning tool performs the discovery stage, it sequentially assigns individual short addresses to each device on the DALI subnet. At the end of the process, the devices' short-addresses can be reprogrammed if required to achieve a more logical order. (The commissioning tool will normally identify the ballast to be reprogrammed by switching it on or off).

If new devices are added to an existing network, short addresses already in use will be avoided.

The commissioning process is separate to the configuration of the devices and only needs to be done once.

DALI Commissioning Tools

Similarly to RDM, a specialised programming tool is required to commission DALI devices. There are not many on the market as commissioning is usually done by a commissioning company. However as DALI becomes more widely used, more programming tools are becoming available.

Dali-Scope

Dali-Scope is small hand-held DALI commissioning tool designed by Artistic Licence.

It is capable of performing auto-discovery, commissioning, programming, channel, group and scene assignments, test and analysis functions.



Tridonic USB DALI Interface/ Programmer

This tool provides all the functions required for DALI commissioning and programming. It also has a detailed Data Monitor that can be useful to track down issues with DALI controllers. Requires a PC.

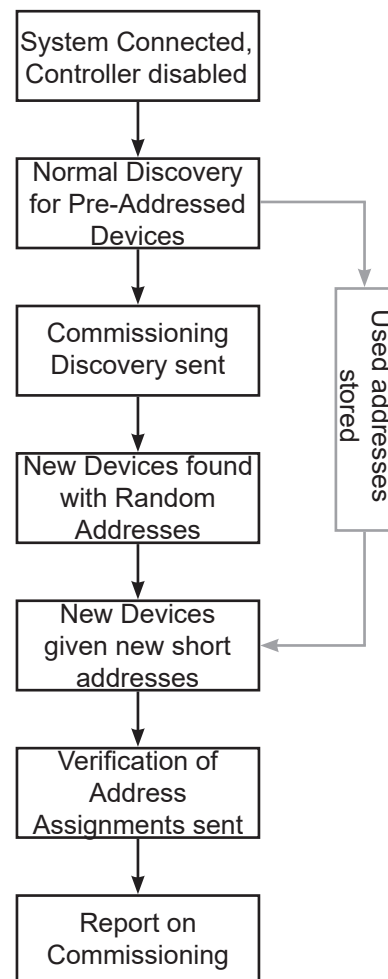

Figure 4: Commissioning Flowchart

DALI Commands

When controlling ballast/device levels, there are four commonly used addressing modes. These are:

- Broadcast – A broadcast message can be sent to all devices to respond to the given value, e.g. Broadcast 50%
- Channel – Individual control over the 64 separate devices (Values: 0% to 100%) e.g. Channel 32 @ 100%
- Group – Each device can be assigned to any of 16 groups. It can be assigned to more than one group, e.g. Group 10 @ 95%
- Scene - Every device can store up to 16 scenes that can be controlled via a single command, e.g. Scene 2 Go

Only one command can be sent per packet so, in order to refresh all 64 devices with different values, 64 separate commands must be sent. This can take up to a second, so DMX-style fast dimming cannot be achieved. Instead, DALI allows a fade time to be specified.

Light output levels are commonly referred to as percentages (fluorescent lamps usually have low resolution fade profiles which do not require the precision of a decimal number).

Table 1 below lists the DALI commands that are commonly used. Several of these can be sent to individual channels or broadcast to the entire subnet.

A key feature of DALI is its ability to get information back from the ballasts; therefore, some commands can be queries or 'set' instructions.

Note that DALI commands that are used for discovery and programming are not included in Table 1.

Command	Addressing Mode	Details
Direct Arc Value	Broadcast / Groups / Channels	Send direct level values
Off	Broadcast / Groups / Channels	Send the off command
Up	Broadcast / Groups / Channels	Increase value by 1 until Max Level, honouring the fade time
Down	Broadcast / Groups / Channels	Decrease value by 1 until Min Level, honouring the fade time
Step Up	Broadcast / Groups / Channels	Increase value by 1 until Max Level, ignoring the fade time
Step Down	Broadcast / Groups / Channels	Decrease value by 1 until Min Level, ignoring the fade time
Recall Max Level	Broadcast / Groups / Channels	Output Max Value
Recall Min Level	Broadcast / Groups / Channels	Output Min Value
Step Down and Off	Broadcast / Groups / Channels	Decrease value by 1 /Turn off
On and Step Up	Broadcast / Groups / Channels	Turn on / Increase by 1
Go to Scene x	Broadcast / Groups / Channels	Go to Scene Command
Status	Channels	Is there a Device using this Short Address?
Device	Channels	Status of the Device
Lamp Power On	Channels	Is the Lamp on?
Version Number	Channels	Replies: Current Version
Device Type	Channels	Replies with the device type
Actual Level	Channels	Query Current Level
Max Level	Channels	Query or Set
Min Level	Channels	Query or Set
Power On Level	Channels	Query or Set
System Failure Level	Channels	Query or Set
Fade Time / Fade Rate	Channels	Query or Set
Scene Levels	Channels	Query or Set

Table 1: Common DALI Commands

DMX and DALI as Partners

With increasing crossover between the entertainment, architectural and commercial lighting sectors, environments that require integration between DMX and DALI equipment are becoming more common.

Careful planning is required as a number of issues must be considered to ensure a successful system. These include the speed differences between the two protocols, the type of control, dimming curves and the commissioning of fixtures.

DMX-to-DALI Conversion

There are situations in which one would like to control DALI ballasts with a DMX controller that is simultaneously being used to control DMX fixtures. An example would be a lighting desk in a theatre that is also used to dim the house lights.

DMXtoDALI quad

In such scenarios, a conversion product such as DMXtoDALI quad from Artistic Licence provides a convenient solution.

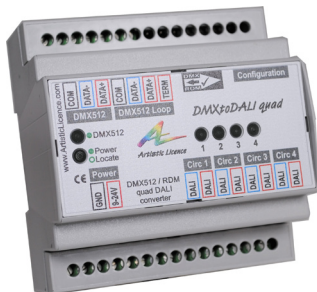

DMXtoDALI quad converts packets from a DMX controller to DALI commands, enabling control of up to four circuits of 64 DALI ballasts each.

The product supports DALI discovery to identify devices on the network, and enables ballasts to be controlled with the usual Broadcast, Channel, Group and Scene commands.

Given the speed differences between DMX and DALI, best results tend to be achieved by sending the lowest number of commands - the Scene command is particularly efficient in this regard, as it enables all the ballasts on a circuit to change using only one command.

DALI-to-DMX Conversion

Conversely, there are also situations in which it is useful to convert DALI into DMX. Consider the following scenario:

A cinema foyer contains an existing DALI controller which is being used to control white fluorescent overhead lighting. The customer wishes to use it to control some new DMX colour-changing lights that are being installed in the foyer. Additionally, there is a media wall on the outside of the building, which is being run by a dedicated DMX controller. The customer would like to be able to trigger shows on the media wall from the DALI controller located in the foyer.

DALIttoDMX

All the above-mentioned functionality can be achieved using the Artistic Licence product, DALIttoDMX, in conjunction with the existing controllers.

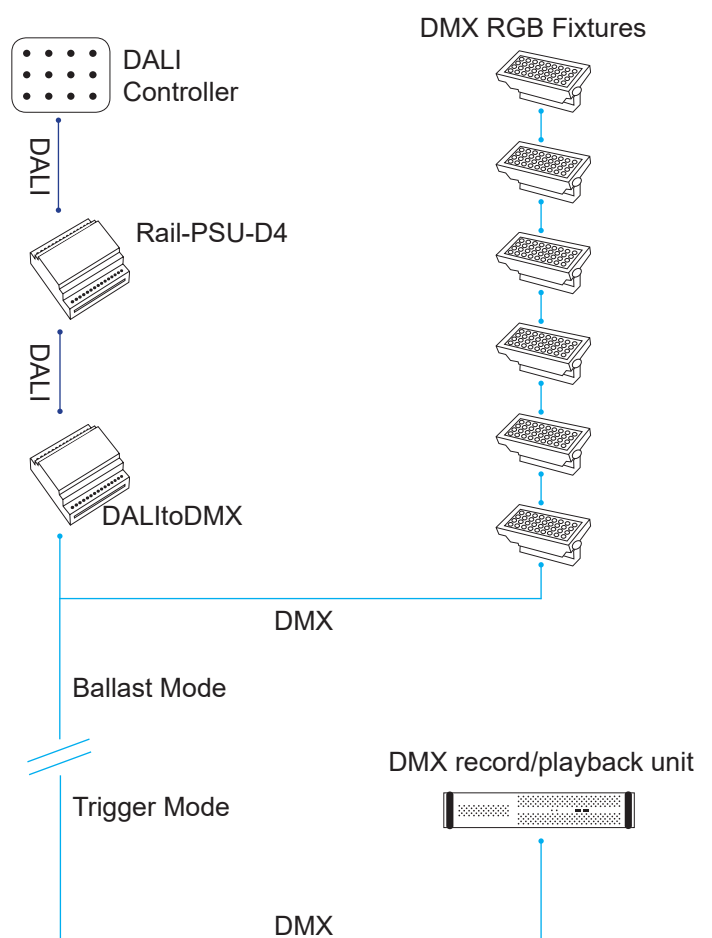

Figure 5: Data flow for DALIttoDMX in Ballast and Trigger Modes

The product has two modes of operation, Ballast or Trigger, as shown in Figure 5 on the previous page. Ballast mode is used to control the DMX colour-changing lights, while Trigger mode is used for the media wall.

In Ballast Mode, DALItoDMX simulates virtual ballasts, each of which has control over a single DMX channel. The usual Broadcast, Channel, Group and Scene commands are supported, and the product offers a choice of 1, 4, 16 or 64 virtual ballasts.

In Trigger mode, the DALI commands serve as data streams that enable sophisticated triggering options.

Dimming Curves

The majority of DMX devices operate using a linear dimming curve with the level selected by a decimal value between 0 and 255.

DALI works with a non-linear (exponential) curve. As the graph shows, each method produces a different output.

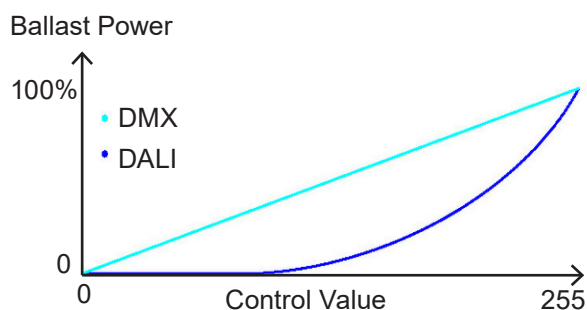

DMXtoDALI quad and DALItoDMX offer the ability to translate between the two curves.

Glossary of Terms

Ballast	Technically, a driver for a light source that communicates using DALI. Often taken to mean the light source itself. Used interchangeably with Device.
Bus	The wire that data travels down.

Circuit	A single DALI line - see Subnet.
Commissioning	The phase that sets up DALI devices for the first time to enable them to be used in a DALI subnet.
DALI	Digital Addressable Lighting Interface
DALI Bus PSU	A PSU that must be present for DALI communication. These are often separate to the controller. Ideally they should be centrally located on a DALI bus.
Device	DALI equipment - usually a light or a sensor. It will require one short address. See also Ballast.
DMX512	Lighting Protocol used in Entertainment style applications.
DSI	Digital Signal Interface
Gateway	A device that allows data transmission between different systems (see also Hub and Router).
Group	A collection of devices that can respond to the same command
Hub	A device that allows data transmission between different systems (see also Gateway and Router).
Router	A device that allows data transmission between different systems (see also Gateway and Hub).
Scene	A level held in device memory that can be recalled with a 'Scene' command
Short Address	The identification number of a DALI device - must be unique on the network and between 0 and 63
Subnet	Synonymous with Circuit. It comprises the DALI controller, a DALI Bus PSU and the device(s).

DALI Specification

- Cable
 - maximum distance: 300 m
 - minimum gauge: 1.5 mm²
 - two-wire system
- Maximum number of devices: 64
- Polarity - None
- Serial Communication
 - Baud rate: 1200 baud
 - Serial Data: 8 bits, 1 start bit, 4 stop bits
 - Manchester coding
- PSU
 - Nominal voltage: 16V
 - Maximum voltage drop allowed: 2V
 - Maximum supplied current: 250 mA



Artistic Licence

The Mould Making Workshop
Soby Mews
Bovey Tracey
TQ13 9JG
United Kingdom

Telephone +44 (0) 20 8863 4515

Email: Sales@ArtisticLicence.com

Support@ArtisticLicence.com

Web: www.ArtisticLicence.com

Due to our policy of continuing product improvement
specifications are subject to change without notice

TECH



help desk

DALI: Trials & Tribulations | By Wayne Howell



Ten years ago, DALI was not a lighting control protocol that regularly came up on my radar.

DMX512 was king and DALI was perceived as a cheap solution for switching fluorescent lamps.

Today, my company, Artistic Licence, ships the same quantity of DMX512 and DALI infrastructure products. So what changed? The answer can be simply put as 'convergence'. We have seen the commercial and retail markets converging with the feature and theatrical markets. It is now perfectly normal for a theatre to want to control their DALI house lights from the lighting console. Equally, a corporate foyer with DALI controlled lights may well need to take control of a DMX512 fixture.

From a technology perspective this is all very 'do-able'. What has not kept pace is knowledge and education for specifiers and installers. It is fair to say that our support desk sees a much higher level of DALI questions compared to DMX512 - and the questions seem to repeat. This article distils the regular questions and hopefully will provide a cheat-sheet for installers and specifiers . . .

POWER

The single biggest cause of confusion with DALI is the bus power supply. DALI controllers can be thought of as similar to volt-free relays. The controller is sending data by repeatedly shorting the two wires together. Absolutely no data will travel over those wires unless someone connects a voltage, and this is the purpose of the bus power supply. It is a 16V DC power supply designed with a special current limiting circuit. A DALI circuit must have a bus power supply connected somewhere. There are no exceptions - it will not work otherwise. The good news is that the bus power supply can be attached anywhere on the DALI circuit. It may even be built in to the DALI controller - so you need to check the user guide.

When looking at a system drawing for a DALI installation, expect to see three categories of power supply. There should be power for the fixtures. There should be a DALI bus power supply. And there should be a power supply for the DALI controller.

Sometimes these are merged together, but if you count fewer than three power supply categories - be sure you know why!

CONVERSION

The next most frequent support issue is usually phrased something like: "The fades seem awfully steppy . . ."

DALI is over 200 times slower than DMX512. It was not designed for subtle, real-time colour mixing. If you try to make a simplistic conversion from DMX512 to DALI and run big colour wave effects, it will look rubbish!

That is not to say you can't link DMX and DALI, you certainly can. But it requires some planning. DALI has some clever addressing modes called groups. Each DALI circuit has 16 groups and they can be controlled fairly quickly. When converting DMX512 to DALI, think in terms of either broadcast or group addressing.

COMMISSIONING

The phrase that sends shivers through our support team is "So what is commissioning then?"

Each DALI circuit can contain up to 64 fixtures. These fixtures will be supplied by the

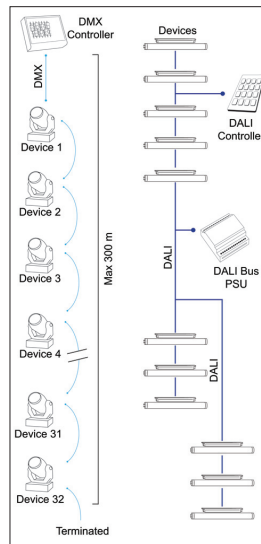

manufacturer in an 'un-commissioned' state. Commissioning is the process by which each of these fixtures is assigned a number in the range 1-64 (the so-called 'short-address'). This short-address is used by the controller to individually control each fixture.

In almost all situations, you will need to commission the DALI fixtures before the controller can do anything. The commissioning process is not complex, simply connect a commissioning tool to the DALI circuit and press the button.

There is one situation where commissioning is not essential: if the DALI controller does not need individual control and all the fixtures are to be controlled as a group. In this situation, the controller can operate in broadcast mode and commissioning is not needed.

CABLE & POLARITY

The cable used for DALI is not specialist - you can use mains cable. The maximum distance is 300m but the gauge of the cable needs to increase as distance increases. Using 1.5mm² will cover most situations.

DALI is polarity independent. The two wires can be connected either way around.

ADDRESSING MODES

I mentioned the DALI group addressing modes earlier, but it is useful to have an overview of DALI addressing when designing an installation. For those familiar with DMX512: *DALI is totally different*. DMX512 is a streaming protocol, which means that all 512 channels are continuously refreshed. DALI is a vector protocol which means that commands are sent to a fixture when a change occurs. DALI has four different methods of sending data to the 64 fixtures that can be connected to a DALI circuit, as follows . . .

Scene: It is important to understand that the designers of DALI viewed it as a system where commands would be issued and fixtures would respond. Scene control underlines this concept. Each fixture can be programmed to hold levels for up to 16 different scenes. The controller can then trigger replay of those scenes with variable fade rates. This is the most effective DALI addressing mode as it requires very little bandwidth.

Broadcast: DALI evolved out of earlier and simpler protocols. Broadcast addressing is how those earlier protocols (such as DSI) worked. Essentially, all fixtures will follow each other. This doesn't give much artistic freedom, but is very useful when you just want to set the level of all fixtures in one room. It is very bandwidth efficient and so provides very responsive control.

Channel: This allows the controller to set the level of each of the 64 possible fixtures individually. This is a very bandwidth-intensive process and trying to use this for real-time effects will almost certainly not give good results.

Group: All of the 64 fixtures can be allocated to any of the 16 possible groups. This provides a good compromise between Broadcast and Channel addressing. This is the mode most widely used when using DALI for dynamic real time effects.

SUMMARY

Artistic Licence has written a DALI Guide which covers the above in more detail. It can be downloaded from the link below . . .

[//tinyurl.com/the-dali-guide](http://tinyurl.com/the-dali-guide)

Wayne Howell is the CEO of Artistic Licence, the lighting controls company that he founded in 1988.

Wayne invented Art-Net and is actively involved in the ESTA technical standards programme.



help desk

DALI & Colour | By Wayne Howell

"DALI-2 adds additional addresses for control interfaces, which means that your control panels no longer need eat into the 64-fixture address space . . ."

My first *Help Desk* column last April covered the basics of DALI. Since then, DALI has been evolving, and so have the questions asked on our Help Desk. So, now seems like a good time to look at what has changed . . .

DALI stands for Digital Addressable Lighting Interface and is a control protocol used widely in architectural and commercial lighting. It has a number of benefits, such as not requiring specialist cable, having polarity independent wiring and low cost.

For those readers more used to entertainment lighting control with DMX512, DALI has two key drawbacks: it only controls 64 fixtures per circuit and it is very slow - around 200 times slower than DMX512.

So, what has changed? DALI-2 is now with us and, perhaps more importantly, DALI-2 products are now in circulation. DALI-2 is fundamentally backwards compatible with DALI, but there are a few areas that can catch out the unwary. DALI-2 brings a number of improvements: it adds additional addresses for control interfaces, which means that your control panels no longer need eat into the 64-fixture address space. The biggest change is the introduction of colour control.

DEVICE TYPES

DALI-1 contained the concept of Device Type (DT) but it was of limited significance to the average user. The table below shows the Device Types defined in DALI-2 . . .

DT Number	Device Type
DT0	Fluorescent lamps
DT1	Emergency lighting
DT2	High intensity discharge
DT3	Low voltage halogen
DT4	General purpose dimmable
DT5	Analogue convertors
DT6	LED modules
DT7	Switching or relay
DT8	Colour control

Device Types DT7 and DT8 did not exist in DALI-1. To a large extent, Device Types in DALI-1 did not affect the actual control system. For example, many LED modules report that they are DT0 (Fluorescent) when they should report DT6 (LED module). As both Device Types have a simple, single-channel intensity control (called ARC) - it does not matter - they can be controlled in the same way. This is not true of DT8.

COLOUR CONTROL

DALI has been used for colour control for many years. Consider an RGB colour mixing fixture: it would have three DT0 or DT6 addresses to control the primary colours. The lighting controller would then treat each primary colour as an independent intensity attribute as shown in *Figure 1*.

This method of control is often called 'emulated ballast operation'. It is widely used but does have its limitations: the controller can only make limited use of DALI groups and has no way to define a specific colour. Equally significant, each fixture uses three valuable addresses.

Wayne Howell is the CEO of Artistic Licence, the lighting controls company that he founded in 1988. Wayne invented Art-Net and is actively involved in the ESTA technical standards programme.

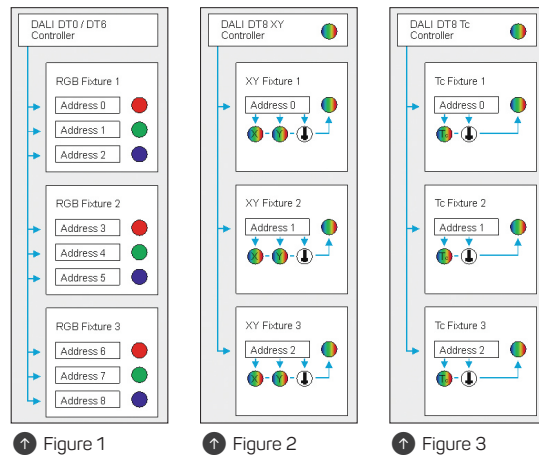

Figure 1 Figure 2 Figure 3

DT8 solves the problem by adding a new set of commands that allow a single fixture to be colour controlled. As there are many different designs of colour changing fixture, DALI-2 introduces the concept of Colour Type. There are four Colour Types: XY, Tc, Primary-N and RGBWAF.

COLOUR TYPE: XY-COORDINATE

XY-Coordinate (*Figure 2*) uses two colour-control channels to set the CIE chromaticity coordinates. The intensity is controlled using the standard DALI ARC command, allowing the controller to separate the selection of colour and intensity. As can be seen from *Figure 2*, only one DALI address is used per fixture. [Note: The intensity control is shown as a fader icon.]

COLOUR TYPE: COLOUR TEMPERATURE (TC)

Colour Temperature (*Figure 3*) control uses a single colour-control channel to set the requested colour temperature of the fixture. Again, intensity is set separately using the conventional DALI ARC command. The unit used to set the colour temperature is the Mirek which is defined as one million divided by the Kelvin colour temperature (Micro Reciprocal Kelvin). For example, a warm white 2700K lamp would be around 370 Mirek. *Figure 3* shows how the colour and intensity control are combined to create the fixture output.

COLOUR TYPE: PRIMARY-N

Primary-N (*Figure 4*) provides individual control over the fixture's native colour channels. If the fixture is an RGB colour mixer, there'd be three colour channels: red, green and blue. This is the simplest and least expensive implementation for the fixture developer and so is likely to be offered by most manufacturers.

Fixtures in Primary-N mode ignore the DALI ARC intensity so the actual light colour and intensity is defined by the colour channels as shown in *Figure 4*. Keep in mind that the make-up and order of the colour channels is defined by the manufacturer - so it could be Blue - Green - Red.

**COLOUR TYPE:
RGBWAF**

RGBWAF (Figure 5) is similar to Primary-N in that it provides control over individual colour mixing elements. The difference is that the meaning and order of the elements is defined as Red - Green - Blue - White - Amber - Free, where Free is an optional manufacturer defined colour.

This Colour

Type also allows a more sophisticated relationship with intensity, such that individual colour elements can be linked to the ARC intensity or not.

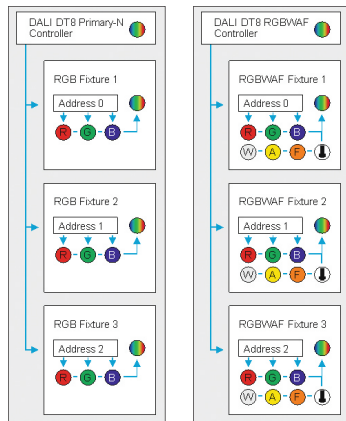

Figure 4

Figure 5

CONCLUSIONS

DT8 does provide some powerful new ways of controlling colour and intensity, but there are some issues that need to be considered when specifying this new type of fixture.

DALI-2 runs at exactly the same speed as DALI-1, so all these new colour features take up bandwidth previously used for intensity. This means that for real time control and colour effects over individual fixtures, the actual number of fixtures per circuit is very limited.

DT8 fixtures may not respond usefully to other Device Type commands. I've seen a number of installations where DT8 control gear has been specified but the controller is DALI-1 and cannot control them. The problem is exacerbated by the fact that the official DALI compliance test equipment is playing catchup with the standard - leaving manufacturers in a difficult position.

DT8 fixtures are not required to support all four Colour Types, so even if the controller and fixture are both DT8, they may not be able to communicate. So when specifying DALI-2 equipment you need to check:

1. Do both controller and fixture support DT0/6?
If so you have a DALI-1 fall back.
2. Do both controller and fixture support DT8? If so:
3. Do both controller and fixture support one or more identical Colour Types?

The situation will inevitably improve over time, but for the moment Device Type 8 can catch out the unwary.

The Lighting Controls Plugfest will be held at The Copthorne Hotel near Gatwick on 25 - 27 April. The Plugfest has been enlarged to include all lighting protocols including DALI. For more information and tickets visit the website. ☒

👉 www.plasa.org/plugfest18

Artistic Licence has written a DALI Guide which covers the basics of DALI-1. It can be downloaded from the link below:

👉 [//plasa.me/thedaliguide](http://plasa.me/thedaliguide)