

0800 0266 383  
cleanair.co.uk

# Cabinet Heaters



 **BENSON  
HEATING**

Forced Draught Gas and  
Oil Fired Cabinet Heaters

VNVD Vertical Heaters

HN/HD Horizontal Heaters

RN/RD Downflow Heaters

# Cabinet Heaters

## Introduction

The Benson range of cabinet heaters combines innovative design with a proven four pass heat exchanger technology to provide a high efficiency cost effective and durable range.

The units may be specified for either free blowing applications or for use with ductwork.

Units are manufactured in accordance with ISO 9001 accreditation, all heater efficiencies are compliant with Part L2B of the 2010 Building Regulations.

## Options

- High/low or fully modulating burners
- Combustion air adaptors
- Stainless steel tubular heat exchanger
- Air inlet spigots
- Air inlet filters
- Manual or motorised inlet dampers
- Up-rated fan motor for increased static pressure

## Applications

- Factories
- Warehouses
- Workshops
- Showrooms
- Greenhouses

## Model Range

Cabinet heaters are available as either gas or oil fired models.

- Gas fired cabinet heaters are suitable for use with Natural Gas (G20), most units can also be specified for Propane (G31)
- Oil fired cabinet heaters are suitable for use with Class D gas oil (35 sec), most units can also be specified for Kerosene (28 sec oil)

Vertical freestanding models are available from 29kW to 380kW

Horizontal and Down flow models from 58kW to 380kW

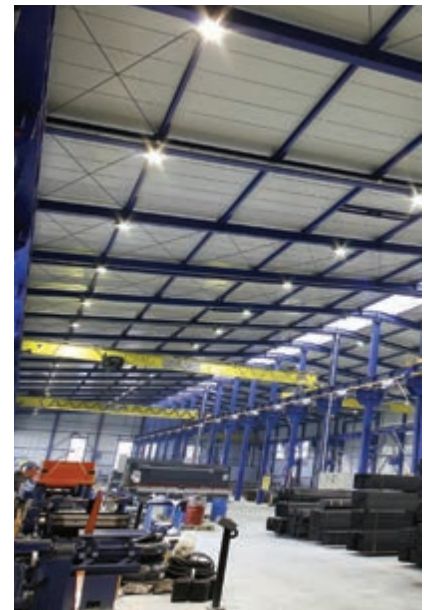



## Specification

### Cabinets

Cabinets are constructed from electro-zinc coated steel with an inner heat shield skin and an epoxy powder coat finish outer skin to form a rigid and durable casework.

### Air Distribution

Centrifugal fan(s) circulate large air volumes evenly across the full heat exchanger surface for enhanced life expectancy. Fans on models 30 to 85 are direct drive with a single phase motor whilst larger models are fitted with a three phase motor and v-belt drive.

Free blowing heaters are fitted with long throw discharge nozzles complete with horizontal louvres and can be rotated through 360°. Models 75-375 are supplied with a raised rear nozzle (one per three nozzle heater and two per four nozzle heater).

Heaters for use with ductwork are supplied with a duct outlet spigot.

### Heat Exchanger and Burner

Four pass combustion chamber/heat exchanger assembly provides improved thermal efficiency with extended life expectancy. A stainless steel chamber is combined with a high efficiency tubular heat exchanger to achieve thermal efficiency in excess of 91%.

The complete assembly is mounted to allow for thermal expansion thereby avoiding undue thermal stress and premature heat exchanger failure.

Gas fired units are fitted with a fully automatic forced draught burner complete with full safety controls to EN676 and the heaters are CE certified. A high/low burner is fitted as standard on model 375.

Oil fired units are supplied complete with a fully automatic burner complete with safety controls and factory fitted fire valve and oil filter. An additional external fire valve may be required in accordance with BS 5410:Part2:1978.

### Controls

A combined fan and limit switch is fitted on all heaters.

In the event of overheating the unit would automatically be shut down by the limit thermostat.

All heaters are supplied with an electronic programmer complete with optimised control, this is factory fitted and wired on free-blowing vertical models. For horizontal, and all duct outlet models down flow heaters the controller is supplied loose for on site wiring by the installer.



### Electric Motors

All electric motors comply with EC motor directive 2005/32/EC

TECHNICAL DATA															
Model Ref		30	35	40	60	75	85	120	135	180	205	235	275	350	375
<b>Gas Fired</b>															
Nominal heat output	kW	29	36	40	58	73	83	117	133	177	206	237	278	350	380
Temperature rise	K	39	42	45	46	43	48	44	41	46	49	44	46	41	45
Gas Consumption Nat gas G20	m <sup>3</sup> /h	3.7	4.4	4.7	6.9	8.5	9.7	13.6	15.3	20.4	23.9	27.2	33.0	40.7	45.8
Gas Consumption propane G31	m <sup>3</sup> /h	1.3	1.6	1.8	2.6	3.2	3.7	5.2	6.0	7.8	9.2	10.4	12.3	16.1	18.1
Minimum inlet pressure Nat gas G20	mbar	17.5	17.5	17.5	17.5	17.5	17.5	17.5	17.5	17.5	17.5	17.5	17.5	17.5	17.5
Minimum inlet pressure propane G31	mbar	37.0	37.0	37.0	37.0	37.0	37.0	37.0	37.0	37.0	37.0	37.0	37.0	37.0	37.0
Gas Connection <sup>2</sup>	Rc	½"	½"	½"	½"	½"	½"	¾"	¾"	1"	1¼"	1¼"	1¼"	1½"	2"
<b>Oil Fired</b>															
Nominal heat output	kW	32	38	43	60	76	82	123	138	184	208	248	265	350	380
Temperature rise	K	43	43	49	47	44	48	46	42	48	50	47	44	41	45
Oil Consumption	l/h	3.4	4.1	4.7	6.5	8.1	9.1	13.3	15.0	19.5	22.5	27.0	34.1	40.4	45.6
Oil Connection <sup>2</sup>	Rc	¾"	¾"	¾"	¾"	¾"	¾"	¾"	¾"	¾"	¾"	¾"	¾"	¾"	¾"
<b>Air Handling Data</b>															
Airflow	m <sup>3</sup> /s	0.61	0.71	0.71	1.03	1.39	1.39	2.15	2.65	3.11	3.4	4.32	4.86	6.88	6.88
Throw <sup>1</sup> (Npzzle outlet)	m	14	14	14	17	17	17	20	20	20	22	22	25	31	31
Static pressure (Ducted)	Std motor	Pa	75	100	100	125	100	100	137	150	175	188	125	175	250
	Increased motor	Pa	n/a	n/a	n/a	n/a	n/a	n/a	175	200	225	225	188	225	n/a
Main fan motor	kW	0.55	0.55	0.55	0.99	0.99	0.99	1.50	2.20	3.0	3.00	4.00	5.50	7.50	7.50
FLC 230/1/50	amp	3.2	4.8	4.8	6.0	7.2	7.2	12.0	14.0	n/a	n/a	n/a	n/a	n/a	n/a
FLC 415/3/50	amp	n/a	n/a	n/a	2.2	2.2	2.2	3.6	5.2	6.5	6.5	8.4	11.0	17.0	17.0
Up-rated fan motor	kW	n/a	n/a	n/a	n/a	n/a	n/a	2.2	3.0	4.0	4.0	5.5	7.5	11.0	11.0
FLC 415/3/50	amp	n/a	n/a	n/a	n/a	n/a	n/a	5.2	6.5	8.4	8.4	11.0	14.0	24.0	24.0
<b>General Data</b>															
Nominal flue diameter	mmø	125	125	125	150	150	175	175	175	200	200	225	225	250	250
Nominal combustion air diameter	mmø	125	125	125	125	125	125	150	150	150	150	150	150	150	150
Noise level <sup>3</sup>	dB(A)	67	69	69	72	72	72	74	76	78	78	79	81	81	81
Net weight	kg	196	196	196	241	243	243	330	332	525	540	630	646	1090	1090

1 Throw is dependent on building height, room temperature and nozzle settings.

2 Gas/oil lines must be adequately sized and reduced at appliance as required.

3 Noise levels measured at 5 metres from appliance.

# Cabinet Heaters

## Vertical Heaters VN/VD

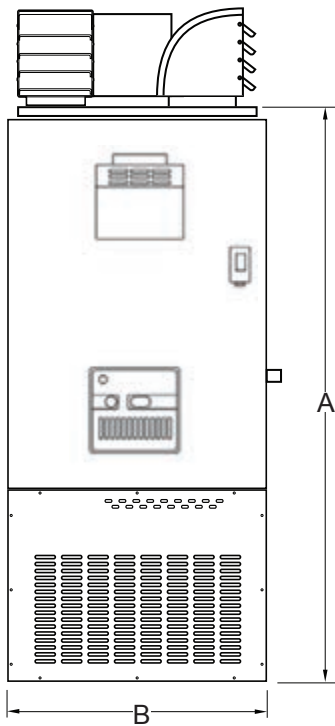
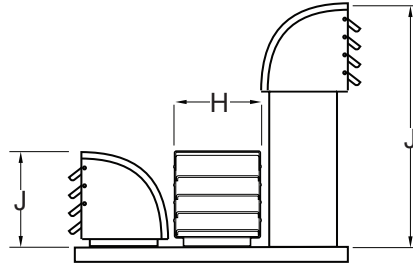

Front View

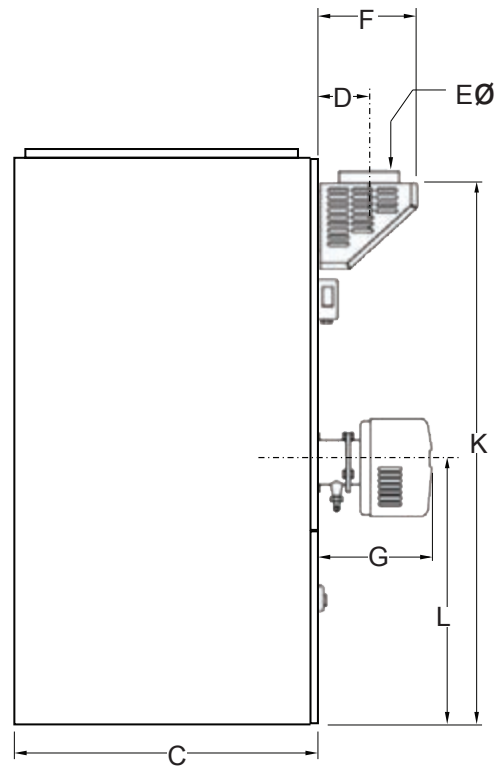

Side View

### DIMENSIONS

Model Ref	30	35	40	60	75	85	120	135	180	205	235	275	350	375
A	1650	1650	1650	1900	1900	1900	2025	2025	2125	2125	2110	2110	2667	2667
B	660	660	660	660	660	660	740	740	916	916	1100	1100	1244	1244
C	662	662	662	925	925	925	1085	1085	1315	1315	1550	1550	1550	1550
D	95	95	95	170	170	170	170	170	195	195	195	195	203	203
E	mmø	125	125	125	150	150	175	175	200	200	225	225	250	250
F		250	250	250	320	320	320	320	380	380	380	380	355	355
G	Oil	229	229	229	267	267	267	298	298	298	476	476	476	476
	Gas	349	349	349	362	362	362	432	432	432	580	580	580	580
H		280	280	280	280	280	305	305	355	355	406	406	474	474
J <sup>1</sup>	Standard	240	330	300	300	330	330	360	360	410	410	460	460	613
	Extended	n/a	n/a	n/a	n/a	660	660	720	720	815	815	915	915	1115
K		1500	1500	1500	1778	1778	1778	1878	1878	1980	1980	1965	1965	2610
L		835	835	835	984	984	984	968	968	1068	1068	1054	1054	1372

1. Heaters with 3 or 4 nozzles are supplied with extended head on the rear nozzle(s). For applications with restricted headroom, units may be specified with all nozzles at standard height.



## Air Discharge and Inlet Details VN/VD

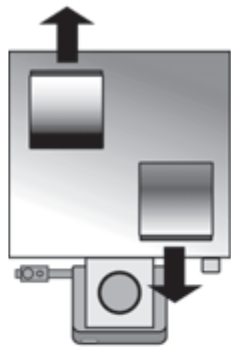

Nozzle outlet 30-60

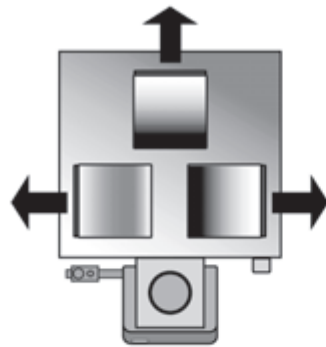

Nozzle outlet 75-120

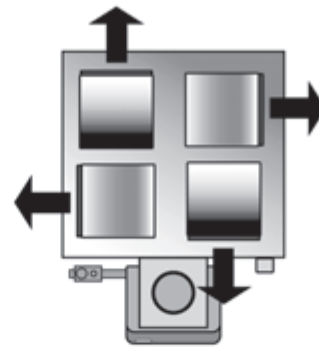

Nozzle outlet 135-375

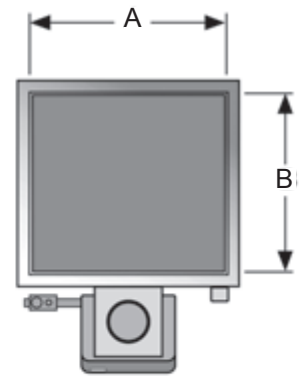

Duct outlet spigot

## Return Air spigots and Filters VN/VD

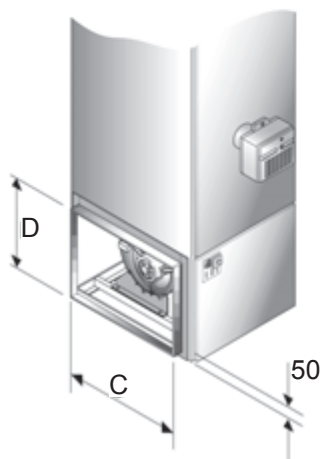

Side inlet spigot  
left (as shown) or right -  
please specify at time of order

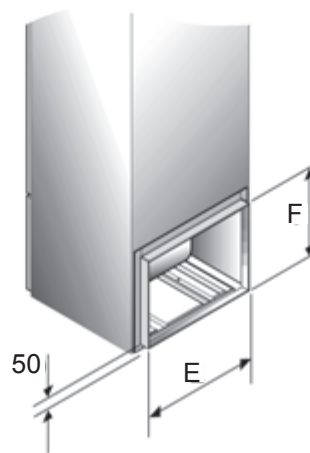

Rear inlet spigot

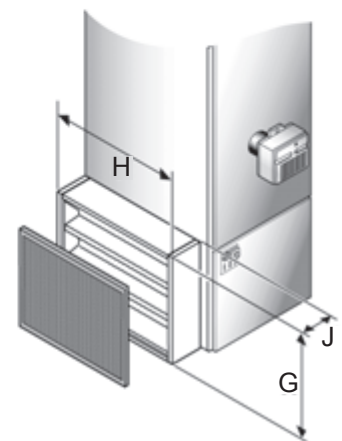

Side inlet filter  
Left (as shown) or right - please specify at time of order.  
Additional side inlet spigot is required to connect filter box to inlet ductwork

## INSTALLATION DIMENSIONS

Model Ref		30	35	40	60	75	85	120	135	180	205	235	275	350	375
Head plan (VN)		1	1	1	1	2	2	2	3	3	3	3	3	3	3
Nozzle detail (VN)	no.	2	2	2	2	3	3	3	4	4	4	4	4	4	4
	Spigot ø	240	240	240	240	240	240	280	280	320	320	370	370	370	370
Outlet Spigot (VD)	A	570	570	570	634	634	634	714	714	890	890	1000	1000	1086	1086
	B	570	570	570	770	770	770	950	950	1120	1120	1450	1450	1365	1365
Side Inlet Spigot (VN/VD)	C	522	522	522	702	702	702	904	904	1078	1078	1145	1145	1150	1150
	D	348	348	348	427	427	427	542	542	692	692	654	654	796	796
Rear Inlet Spigot (VN/VD)	E	620	620	620	520	520	520	608	608	790	790	935	935	n/a	n/a
	F	445	445	445	550	550	550	550	550	560	560	654	654	n/a	n/a
Inlet Filter Assembly (VN/VD)	G	420	420	420	600	600	600	680	680	765	765	720	720	860	860
	H	660	660	660	800	800	800	990	990	1165	1165	1245	1245	1530	1530
	J	300	300	300	300	300	300	300	300	300	300	450	450	450	450
<b>Installation Clearances</b>															
Front		500	500	500	500	500	500	600	600	600	900	900	900	900	900
Side		300	300	300	300	300	300	300	300	300	300	400	400	500	500
Rear		700	700	700	1000	1000	1000	1200	1200	1500	1500	2000	2000	2000	2000

Filter cassettes can be withdrawn from either side, ensure adequate clearance for withdrawal i.e. full width of filter box.

# Cabinet Heaters

## Horizontal Heaters HN/HD

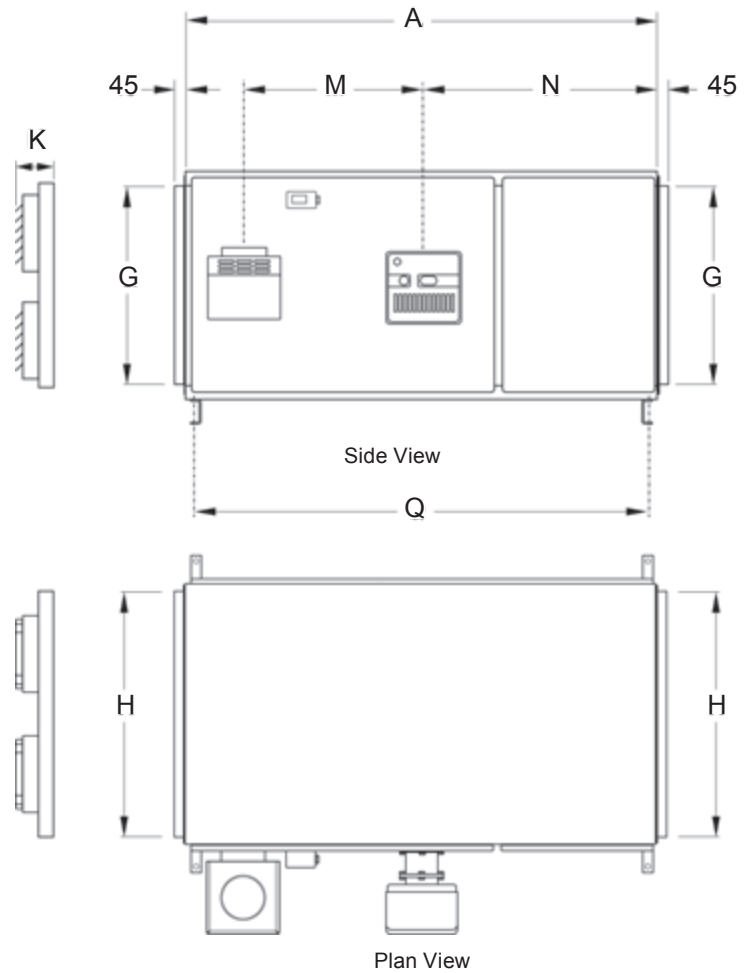
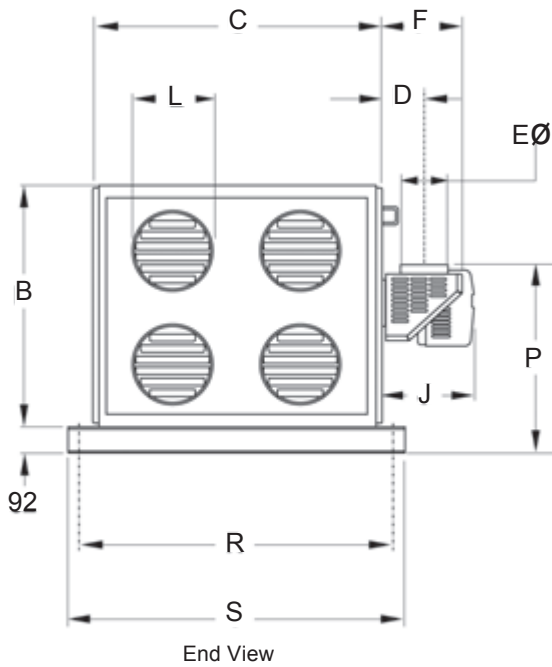

Note: Units may be specified for airflow right to left which is the standard configuration as shown. Alternatively units can be specified for airflow left to right.

### DIMENSIONS

Model Ref	60	75	85	120	135	180	205	235	275	350	375
A	1865	1865	1865	1993	1993	2093	2093	2076	2076	2667	2667
B	660	660	660	740	740	916	916	1100	1100	1244	1244
C	925	925	925	1085	1085	1315	1315	1550	1550	1550	1550
D	170	170	170	170	170	200	200	225	225	203	203
E	mmø	150	150	175	175	175	200	200	225	225	250
F		320	320	320	320	320	380	380	380	380	355
G		560	560	560	640	640	816	816	1000	1000	1086
H		790	790	790	952	952	1182	1182	1450	1450	1365
J	Oil	267	267	267	298	298	298	476	476	476	476
	Gas	362	362	362	432	432	432	580	580	580	580
K		160	160	160	225	225	320	320	320	320	320
L	mmø	209	209	209	290	290	425	425	425	425	480
M		676	676	676	790	790	790	790	769	769	1054
N		984	984	984	968	968	1068	1068	1054	1054	1372
P		568	568	568	607	607	740	740	840	840	1396
Q		1806	1806	1806	1934	1934	2034	2034	2020	2020	2612
R		1081	1081	1081	1244	1244	1474	1474	1750	1750	1750
S		1157	1157	1157	1320	1320	1550	1550	1826	1826	1826



## Downflow Heaters RN/RD

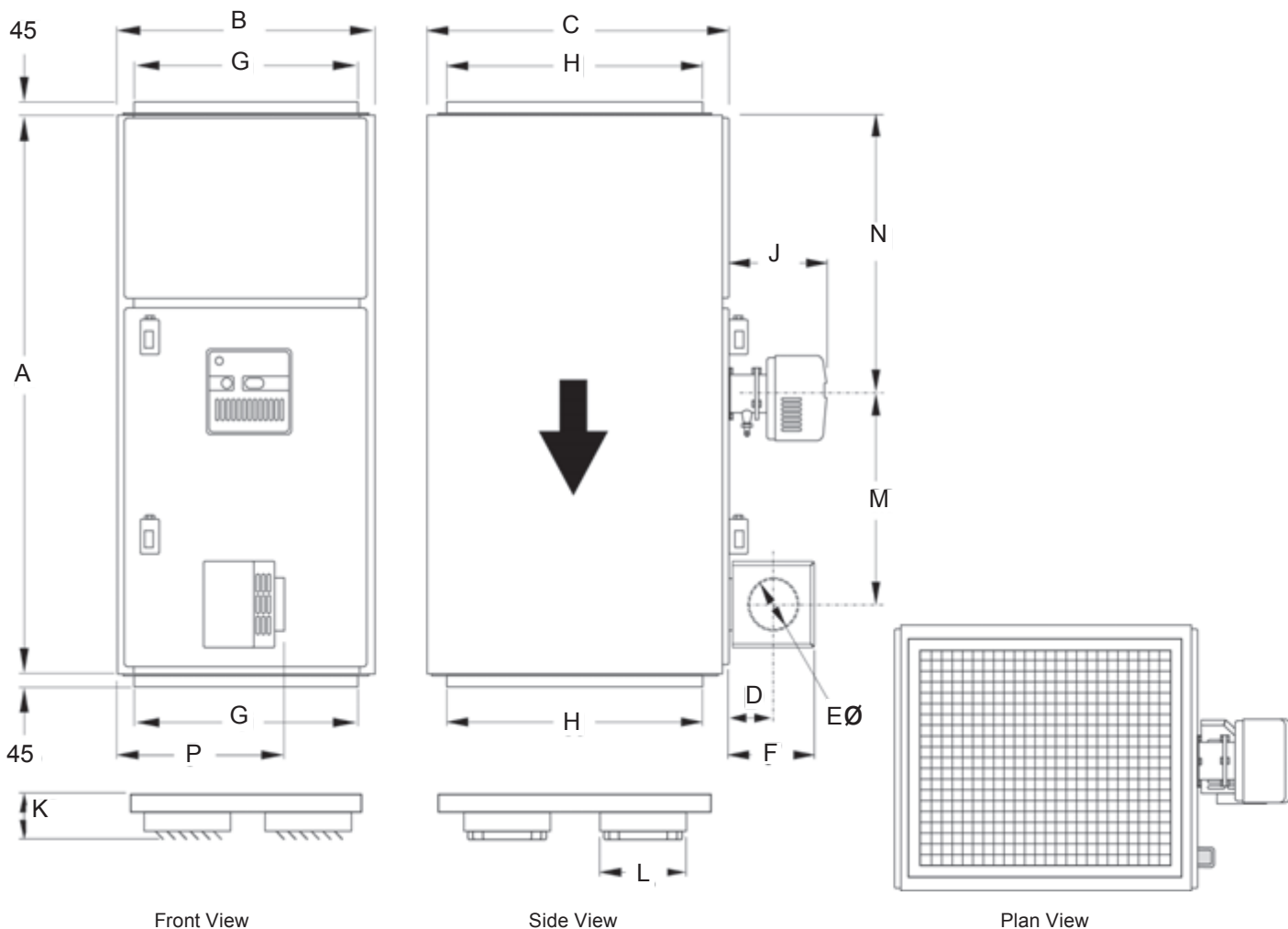

DIMENSIONS											
Model Ref	60	75	85	120	135	180	205	235	275	350	375
A	1865	1865	1865	1993	1993	2093	2093	2076	2076	2667	2667
B	660	660	660	740	740	916	916	1100	1100	1244	1244
C	925	925	925	1085	1085	1315	1315	1550	1550	1550	1550
D	170	170	170	170	170	200	200	225	225	203	203
E	mmø	150	150	175	175	175	200	200	225	225	250
F		320	320	320	320	320	380	380	380	380	355
G		560	560	560	640	640	816	816	1000	1000	1086
H		790	790	790	952	952	1182	1182	1450	1450	1365
J	Oil	267	267	267	298	298	298	476	476	476	476
	Gas	362	362	362	432	432	432	580	580	580	580
K		160	160	160	225	225	320	320	320	320	320
L		209	209	209	290	290	425	425	425	425	480
M		676	676	676	790	790	790	790	769	769	1054
N		984	984	984	968	968	1068	1068	1054	1054	1372
P		476	476	476	515	515	648	648	748	748	1304

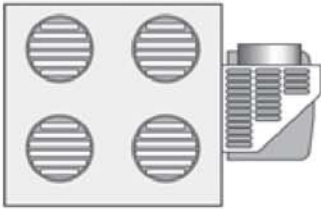

Discharge outlets (HN/RN)

(All HN/RN models are supplied with 4 louvred outlets)

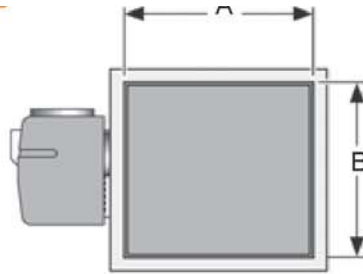

End inlet spigot (HN/RN HD/RD)

(Burner location shown for standard R-L horizontal airflow)

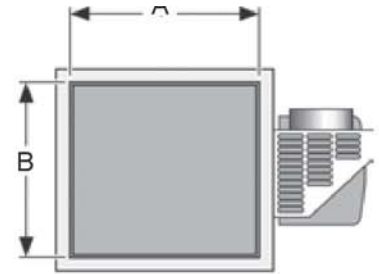

Outlet spigot (HD/RD)

(Flue location shown for standard R-L horizontal airflow)

### Alternative Return Air Spigots

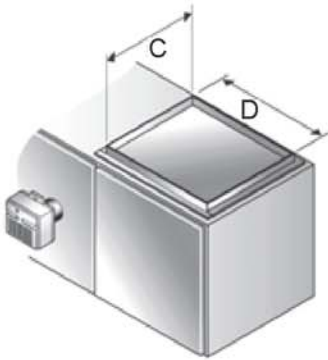

Top or bottom inlet spigot  
HN/HD

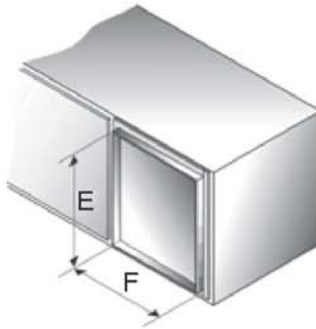

Rear inlet spigot  
HN/HD



Side inlet spigot  
RN/RD

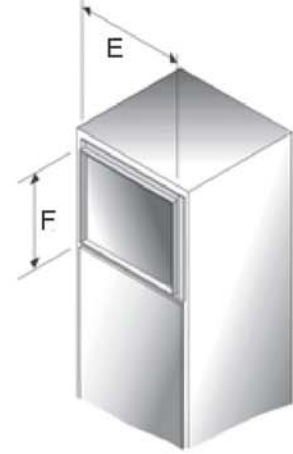

Rear inlet spigot  
RN/RD

### Air Filters

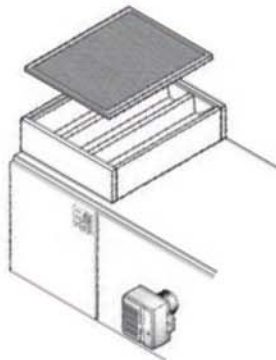

Top or bottom inlet filter  
HN/HD

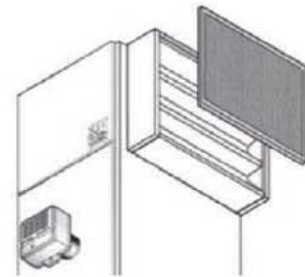

Side inlet filter  
RN/RD

INSTALLATION DIMENSIONS												
Model Ref		60	75	85	120	135	180	205	235	275	350	375
Nozzle $\phi$ (HN/RN)		203	203	203	284	284	419	419	419	419	470	470
Duct Spigot (All)	A	790	790	790	952	952	1182	1182	1450	1450	1365	1365
	B	560	560	560	640	940	816	816	1000	1000	1086	1086
Top & Side Inlet (HN/HD & RN/RD)	C	702	702	702	904	904	1078	1078	1145	1145	1150	1150
	D	427	427	427	542	542	692	692	654	654	796	796
Rear Inlet (HN/HD)	E	520	520	520	608	608	790	790	935	935	n/a	n/a
	F	520	520	520	550	550	560	560	654	654	n/a	n/a
<b>Installation Clearances</b>												
Front		500	500	500	600	600	600	900	900	900	900	900
Top (RN/RD)		150	150	150	150	150	150	150	150	150	150	150
Top <sup>1</sup> (HN/HD)		150	150	150	150	150	150	150	400	400	500	500
Rear		1000	1000	1000	1200	1200	1500	1500	2000	2000	2000	2000

<sup>1</sup> Top clearance applies to units with side air inlet. For units with top air inlet allow 1000mm



creating a better work environment

### CLEAN AIR GROUP

5 Newton Close, Drayton Fields  
Daventry, Northants NN11 8RR

Tel: 01327 301 383  
Fax: 01327 301 384

info@cleanair.co.uk  
www.cleanair.co.uk

Clean Air Group is a trading style of Clean Air Installations Limited Reg. in England No.3915686 and Clean Air Facilities Limited Reg. in England No.3965661

Benson Heating Ltd is a registered trademark of AmbiRad Limited. Because of continuous product innovation, Benson Heating reserves the right to change product specification without due notice.

GB/BEN/009/0611