

# ATN

NEW

## MYGALE 23

TRACKED SPIDER LIFT  
MYGALE 23



[www.atnplatforms.com](http://www.atnplatforms.com)

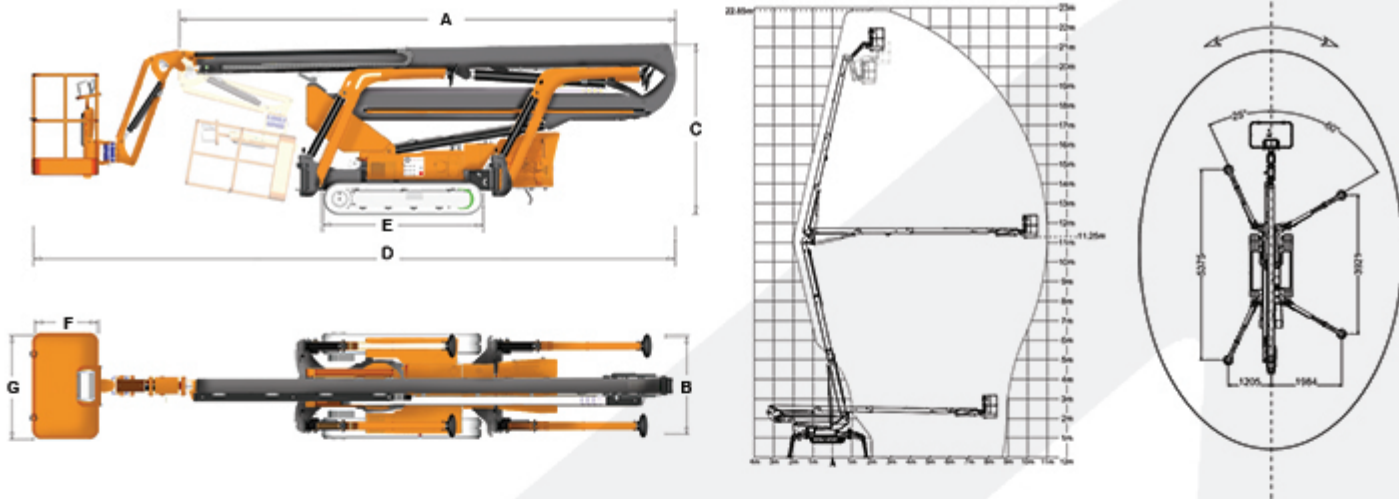

## ADVANTAGES

- From 0 to 23 m. in less than a minute.
- Manoeuvrability, simple controls.
- Easy access to hydraulic and electric components.
- Standardisation of components.

## STANDARD FEATURES

- Non-marking rubber tracks.
- Slings rings.
- Overload sensor.
- Onboard colour LCD diagnostic console.
- Tilt indicator with buzzer.
- Hour meter.
- 220V power supply, dual energy.

## OPTIONS

- Compressed air line.
- Flashing light.
- Motion alarm.
- Special customer paint colour(s).

<b>MYGALE 23</b>	
Working height	22,85 M (74 ft. 9.67 in.)
Platform height	20,85 M (68 ft. 4.05 in.)
Min. floor height	0,39 M (1 ft. 2.79 in.)
Horizontal reach	11,00 M (36 ft. 0.89 in.)
Up and over height	11,25 M (36 ft. 9.09 in.)
Lift capacity	230 Kg (507 lbs.)
Ground bearing pressure on tracks	65 Kn/m <sup>2</sup>
Max wind speed	45 Km/h (41 ft/s (27.9 mph) )
<b>A</b> Length - storage	5,54 M (18 ft. 1.75 in.)
<b>B</b> Width	1,19 M (3 ft. 9.04 in.)
<b>C</b> Height	1,93 M (6 ft. 3.32 in.)
<b>D</b> Length	6,68 M (21 ft. 9.16 in.)
<b>E</b> Wheelbase	1,42 M (4 ft. 6.58 in.)
<b>F</b> Platform depth	0,73 M (2 ft. 3.95 in. Mph)
<b>G</b> Platform width	1,19 M (3 ft. 9.04 Mph)
Ground clearance centre	0,17 M (0 ft. 5.57 in.)
Track	0,72 M (2 ft. 3.62 in.)
Track width	0,23 M (0 ft. 7.54 in.)
Surface with outriggers	3,97 x 3,92 M (13 ft. 0.24 in. x 12 ft. 8.60 in.)
Max. slope (lengthways)	35 %
Max. ground bearing pressure on levelling jacks	154 Kn/m <sup>2</sup>
Diesel engine	KUBOTA
Fuel tank capacity	25 L
Hydraulic tank capacity	60 L
Weight	This product complies with European regulations in force 3300 Kg (7275 lbs.) (EN 280). Due to our constant improvement policy, ATN reserves the right to make any modifications without any prior notice.
Power	12,5 kW @ 3600 tr/mn



Rue André Thevet,  
Z.I. Guillaume Mon Amy Fauillet 47400 FRANCE  
**+33 (0) 553 798 320 +33 (0) 553 880 107**  
<http://www.atnplatforms.com>

