



CONCESSION TRAILERS



BUILT FOR THE LONG HAUL



MERCHANDISING, FOOD & BEVERAGE VENDING, AND GAME TRAILERS



YOUR SATISFACTION IS OUR BUSINESS.

At United Trailers, our goal is to make sure that you are completely satisfied with your concession trailer. We take the time to listen to your needs, and then build the trailer to your specifications. For over 20 years, we have been building custom trailers with premium materials and solid construction. Your options are almost limitless with our long list of available accessories, along with various sink packages and window configurations. Experience the United Trailers difference today!



POPULAR ACCESSORIES



Interior of concession trailer shown with custom cabinets, white metal walls and ceiling, and sink package. This trailer also features a non-powered roof vent, interior countertop under the serving windows, and marble-look vinyl flooring.



Trailer with custom cabinets, white metal walls and ceiling, sink package, tinted window, awning door with fluorescent light, extruded aluminum floor, RV door, serving windows, water heater, 110v pump on demand, and 2 non-powered roof vents.



Awning door with fluorescent light and exterior removable shelf under serving window



Serving windows, countertop and fluorescent lights



Removable tongue



500w recessed quartz light

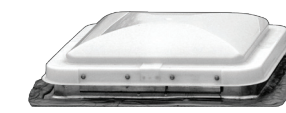

Roof vent (non-powered)



Flush fender skirt



Marquee with graphics and lights (we build the marquee, you supply the graphics and lights)



RV door with window and screen door



30 lb. LP tanks with cover

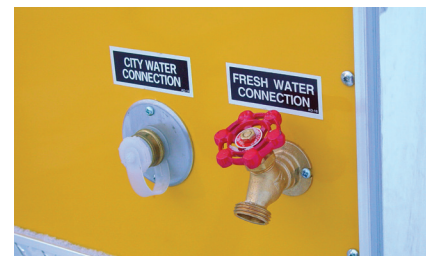

City fill and spigot

POPULAR FLOORING OPTIONS

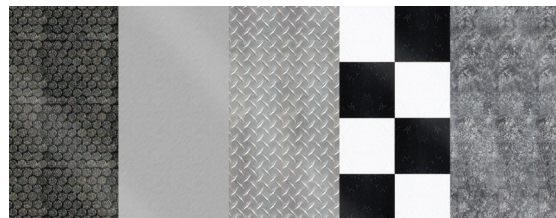

European non-skid .080 smooth aluminum Aluminum tread plate Black and white vinyl Marble-look vinyl

SINK PACKAGES

Four sink package with right hand wash sink

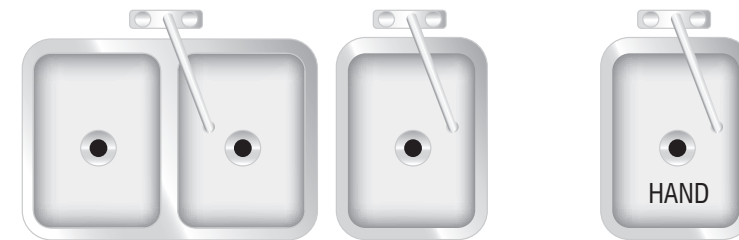

Four sink package with left hand wash sink

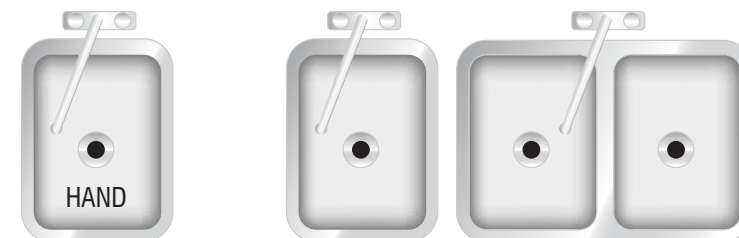

Custom sink packages are also available.



MANY MORE OPTIONS AVAILABLE! SEE YOUR UNITED TRAILERS DEALER FOR COMPLETE LIST OF OPTIONS.



WINDOW DIAGRAMS

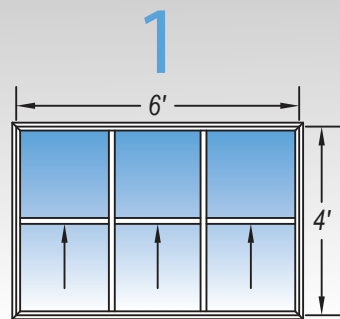

3 Vertical Sliders

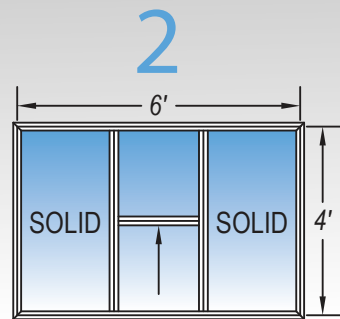

2 Stationary Windows
1 Vertical Slider

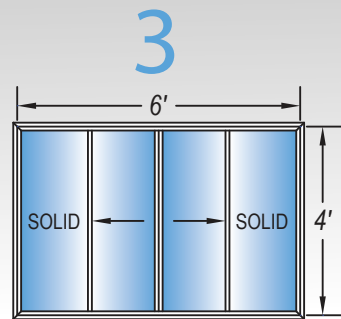

2 Stationary Windows
2 Horizontal Sliders

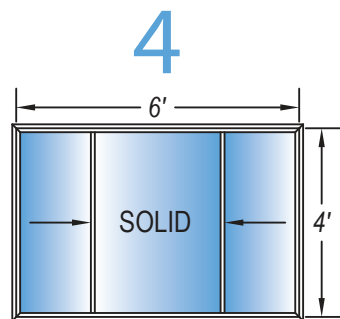

1 Stationary Window
2 Horizontal Sliders

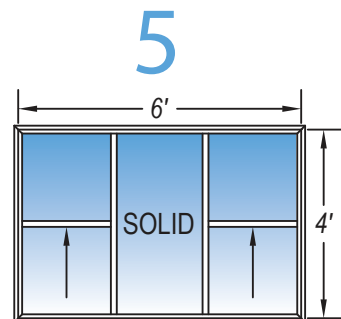

1 Stationary Window
2 Vertical Sliders

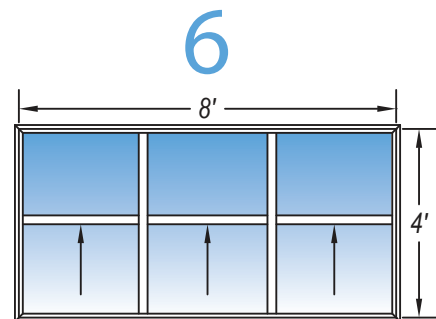

3 Vertical Sliders

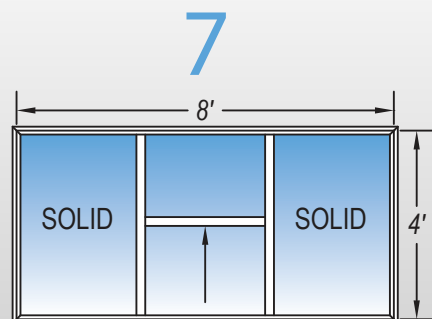

2 Stationary Windows
1 Vertical Slider

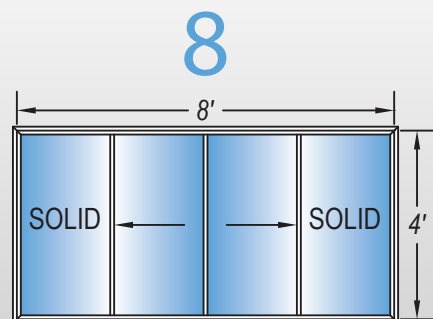

2 Stationary Windows
2 Horizontal Sliders

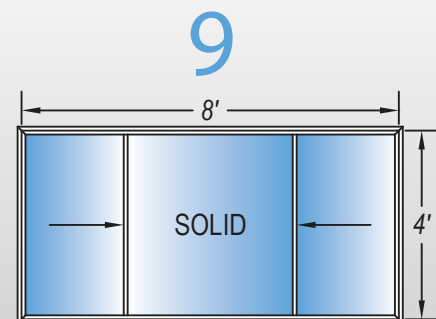

1 Stationary Windows
2 Horizontal Sliders

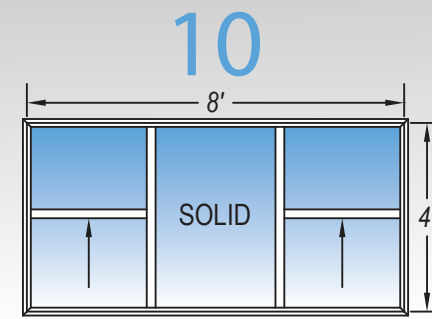

1 Stationary Window
2 Vertical Sliders

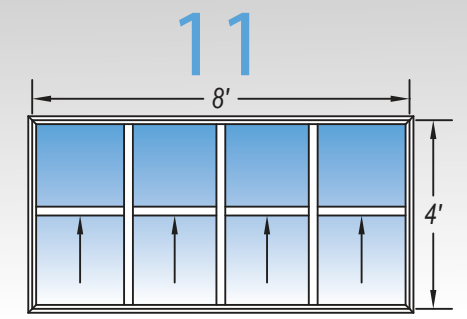

4 Vertical Sliders

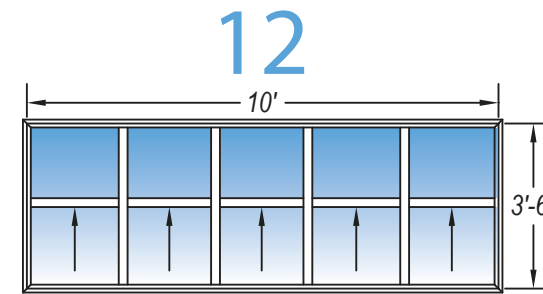

5 Vertical Sliders

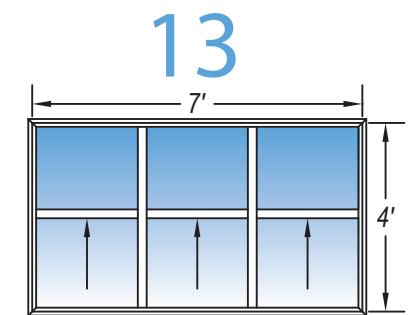

3 Vertical Sliders

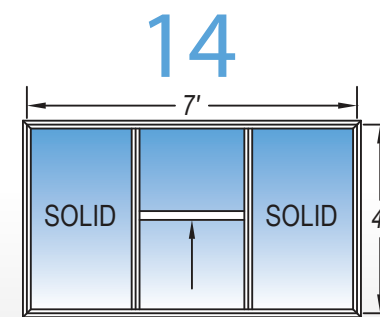

2 Stationary Windows
1 Vertical Slider

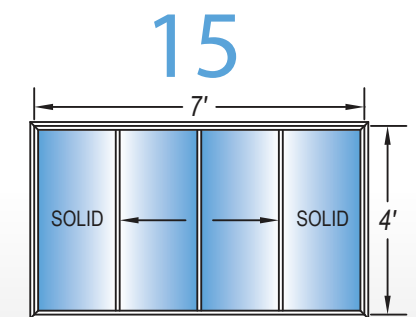

2 Stationary Windows
2 Horizontal Sliders

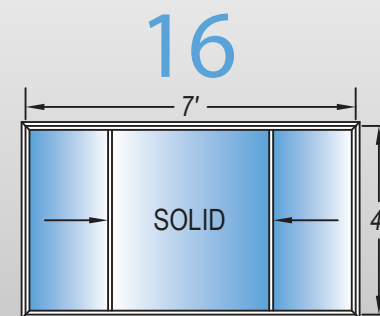

1 Stationary Windows
2 Horizontal Sliders

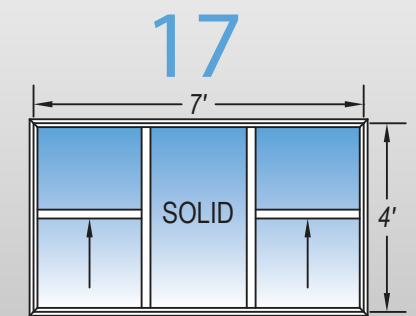

1 Stationary Windows
2 Vertical Sliders



SOLID CONSTRUCTION

- 1** The rear corner posts and header are made of quality steel to provide a solid framework.
- 2** An extra wallpost is added to the front and rear of each wheel area to provide added support for the wall.
- 3** Rubber torsion axles with E-Z Lube hubs are standard. All models with over 3,000 lb. GVWR ratings come with electric brakes.
- 4** Trailer-rated radial tires and axles provide maximum performance and safety.
- 5** Heavy-duty steel square outriggers are welded to the outer wall for added stability and strength.
- 6** Where the wiring passes through steel, grommets are used to prevent electrical shorts.
- 7** The lower section of every trailer is sprayed with a special protective undercoating.

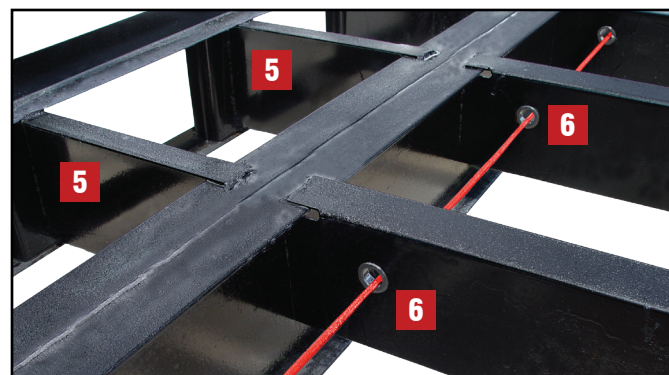

- 8** Each trailer has a special barrier to minimize corrosion from electrolysis. All exterior sheet metal screws are warranted for 5 years against corrosion.
- 9** A 6" tubular steel tongue is standard. A third member is added on:
 - A. Trailers with a GVWR of 9,900 lbs. or more
 - B. Trailers with an extended tongue
 - C. Trailers with a pintle eye coupler
- 10** Steel cross-members run between the I-beams to support the floor. Spacing is determined by the information you provide the dealer. 24" spacing is standard on round top models and 16" is standard on flat top models.
- 11** All walk-in door framing is 1" x 3" rectangular channel for a straighter perimeter.
- 12** Two heavy-duty steel I-beams provide a solid foundation for your trailer. On trailers with 5200 lb. axles or that are 20' and longer, 2 additional I-beams are added to 60% of the trailer length.
- 13** Steel top rails are used to frame a stronger, straighter roof line.
- 14** Steel roof bows and steel wall studs provide solid upright support.



STANDARDS, SPECS & COLORS

SPECIFICATIONS

	ROUND TOP			FLAT TOP		
	U-8.516TA35	U-8.518TA35	U-8.520TA35	UXT-8.516TA35	UXT-8.518TA35	UXT-8.520TA35
3,500 lb. Rubber Torsion Brake Axle(s)	2	2	2	2	2	2
Floor Height	22"	22"	22"	24"	24"	24"
GVWR (lbs.)	7,000	7,000	7,000	7,000	7,000	7,000
Hitch Height	18"	18"	18"	18"	18"	18"
Interior Length	16' 5"	18' 5"	20' 5"	16' 5"	18' 5"	20' 5"
Overall Body Length	16' 9"	18' 9"	20' 9"	16' 9"	18' 9"	20' 9"
Overall Height	8' 8 3/4"	8' 8 3/4"	8' 8 3/4"	8' 7"	8' 7"	8' 7"
Overall Width	8' 6"	8' 6"	8' 6"	8' 6"	8' 6"	8' 6"
Rear Door Opening Height	6' 3"	6' 3"	6' 3"	6' 3"	6' 3"	6' 3"
Rear Door Opening Width	7' 8"	7' 8"	7' 8"	7' 8"	7' 8"	7' 8"
ST205/75R15(C) Radial Tires	std.	std.	std.	std.	std.	std.
Width Between Wheel Wells	81"	81"	81"	81"	81"	81"

NOTE: Other trailer models available. Please see your United Trailers dealer for additional information.

AVAILABLE COLORS



*Color match for metallic colors not available on front trailer caps. Caps are available in black, white and red only.

STANDARD FEATURES

- (2) 12-Volt Dome Lights With Switch
- .030 Smooth Aluminum Exterior
- 16" On-Center Wall Posts
- 24" Aluminum Treadplate Stone Guard
- 16" On-Center Floor & Ceiling
- 24" to 32" Side Door (Depending on Trailer Length)
- 3/4" Plywood Floor w/25 year warranty
- 2-5/16" Coupler w/Jack for GVWR more than 3000 lbs
- 6' 8" Interior Height*
- Bright Aluminum Front Corners
- Electric Brakes, All Axles
- LED Tail and Clearance Lights
- Double Swing Rear Doors with Cam Lock
- E-Z Lube Hubs
- Independent Torsion Axles
- Light-Weight Steel Uni-Body Construction
- Safety Chains
- Trailer Rated Radial Tires
- Weatherguard Coating on Fasteners
- Available in 14 colors

*Interior height subject to change by model

Your Authorized United Trailers Dealer:



Units may be shown with optional features. Please see your dealer for current standard specifications and options. We reserve the right to change specifications at any time, without incurring obligation.



19985 County Road 8 • Bristol, IN 46507
 Phone: 574.848.7088 • Toll Free: 800.637.2592
 www.united-trailers.com

Form Concession0115R819