

# Hafner valves with Namur interface

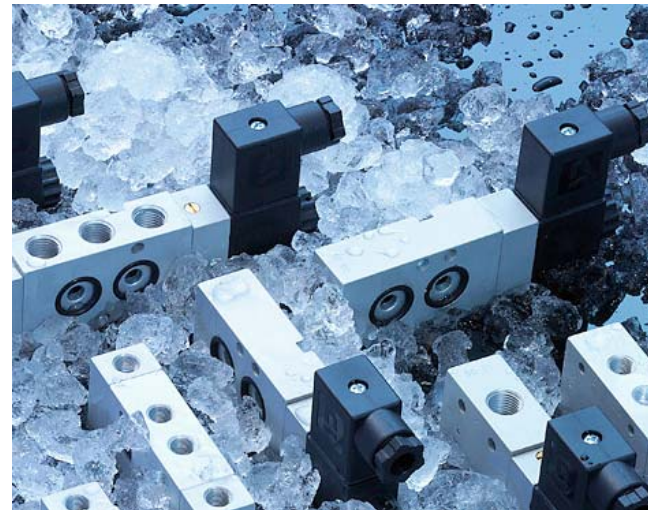

**With the standard MNH 310 701 and MNH 510 701 Hafner offers really competitive products. But the Namur-range includes a lot more:**

- Competitive Advantage of **coil-protection against moisture**
- **G 1/4"** and **G 1/2"** standard
- Air- or combined **spring return**
- Different **port-schemes**
- Namur Flex which can be used as 3/2-way and 5/2-way valve
- Valves with **BSP** and **NPT** threaded ports
- Different **manual overrides**
- Vast range of **accessories**
- ATEX-approved **EEx-products**
- Maximized **flow** (series 101)
- Different **materials** in use e.g. brass-free-products
- Valves entirely made of **316L stainless steel**
- Valves for **low temperature applications (-50° C)**
- Non standard items, products designed on customer's requests



**Besides maximum flow of 1.250 l/min in a compact design there are 11 more competitive advantages of the Hafner Namur valves series 701.**

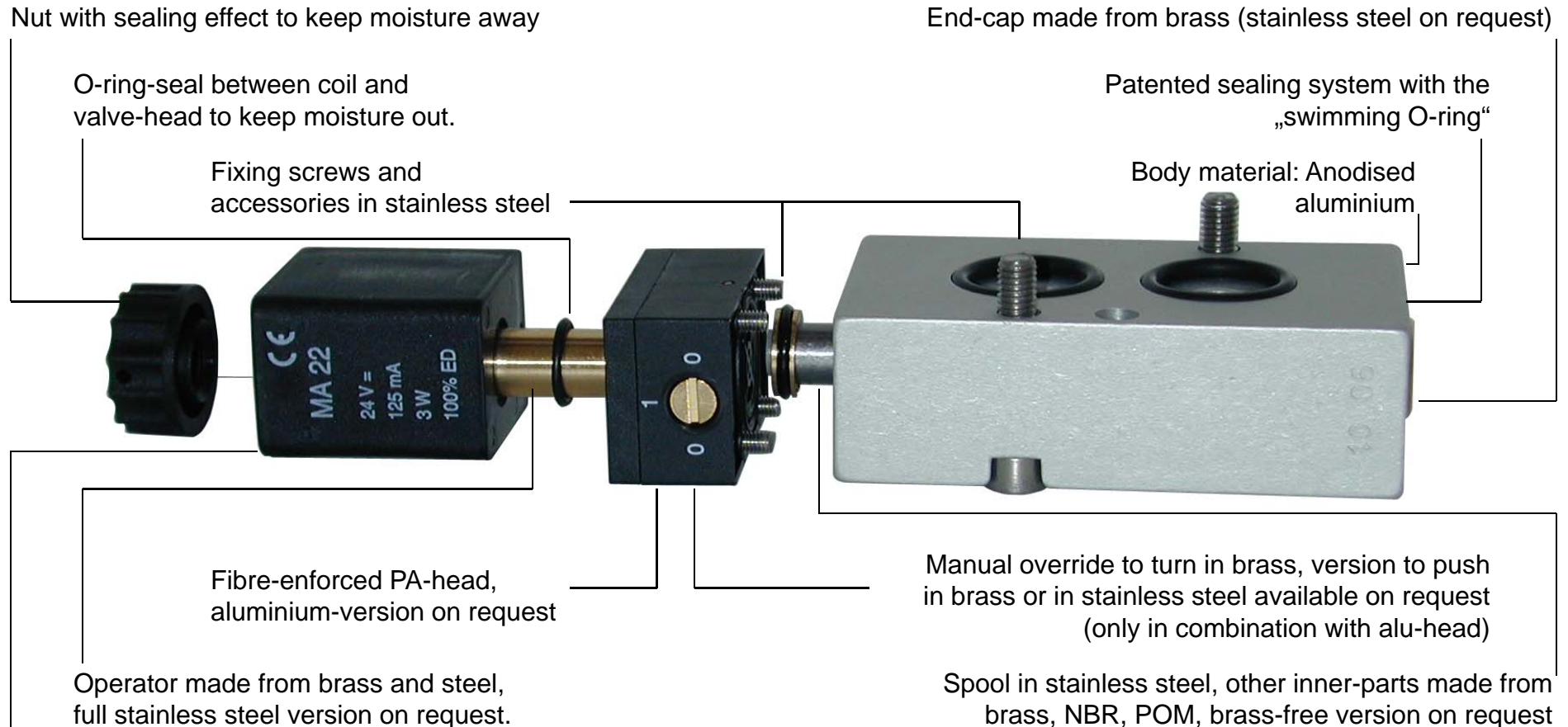

Fully encapsulated thermoplastic coil, 360° rotation.  
 Standard power consumption 3 Watt, 5 VA, 6 voltages.  
 Solenoid system with 2 Watt (only 24DC) on request.  
 Thermoset resin coils and EEx-solenoid systems class m and ia available on request.



**Hafner uses a special coil with covered yoke and additional seals between the coil and valve. Besides IP65 we are also offering IP67.**

**The yoke of the MA 22 standard coil is completely covered in Polyamide. This prevents the yoke from rusting and as a result not to burn out.**



**Additionally an O-Ring between the operator tube and the coil protects the electrical part from moisture.**



**Using our Epoxy-coil, the special connector (with moulded cable) and a second O-ring, the system reaches protection class IP67 in accordance to IEC 60 529.**

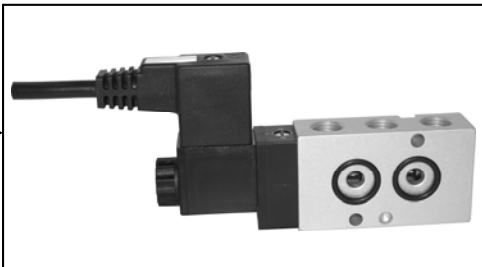

# Hafner offers a wider range of valves with Namur interface than most of our competitors.

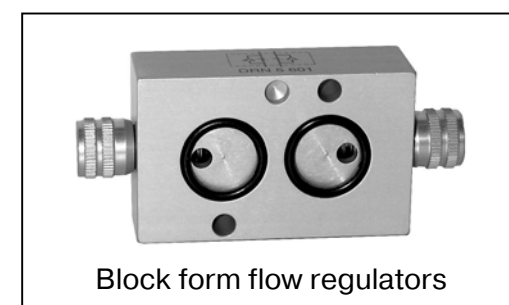
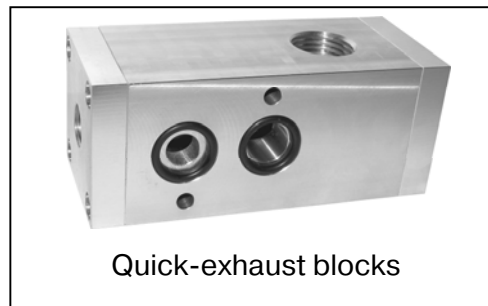
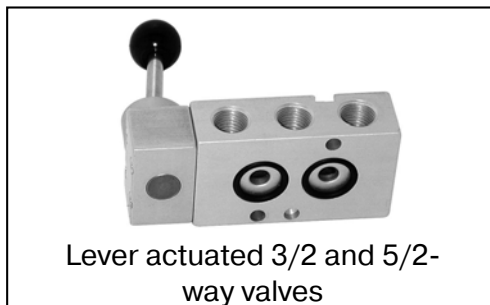
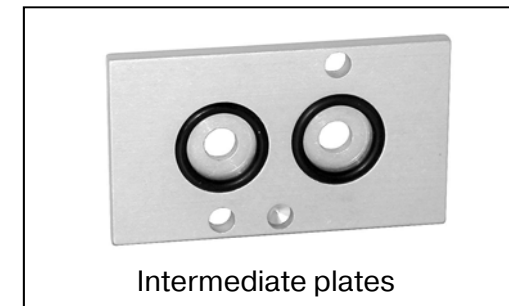
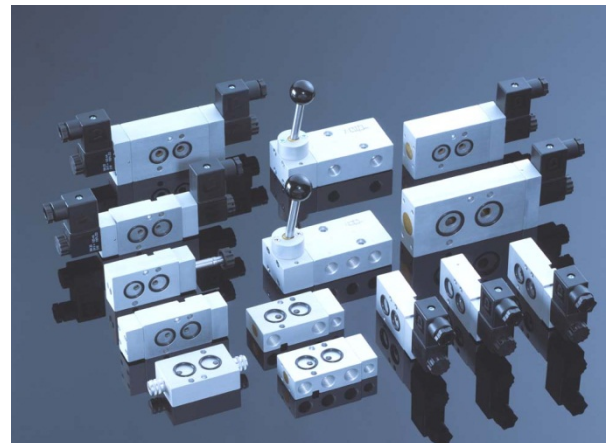
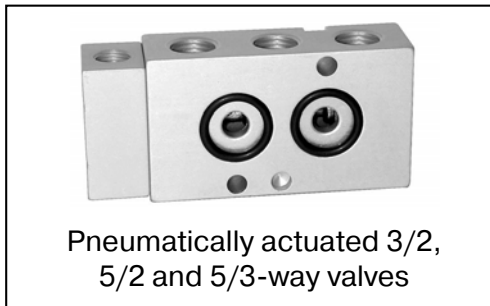
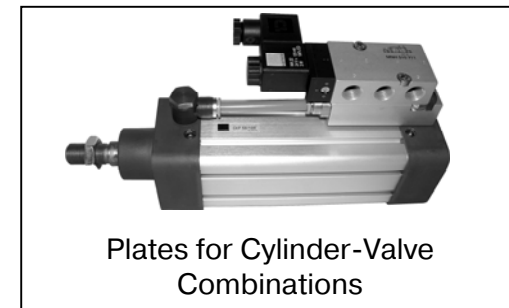
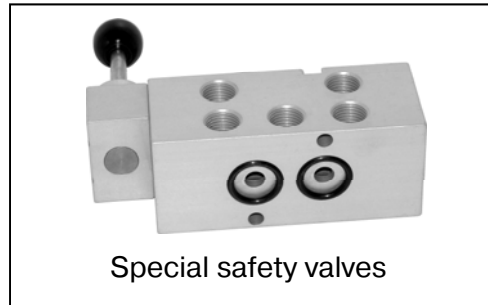
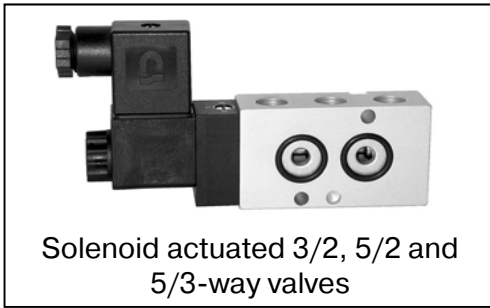

The 1/4" standard as well as the 1/2" standard are part of our range.

### Namur standard: Drawing of the actuator flange

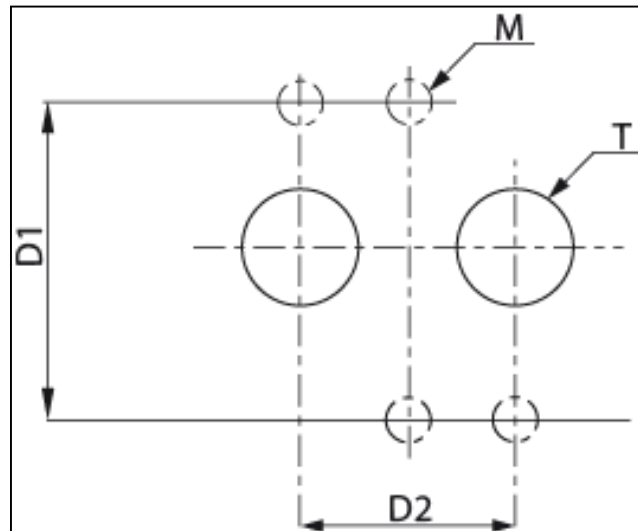
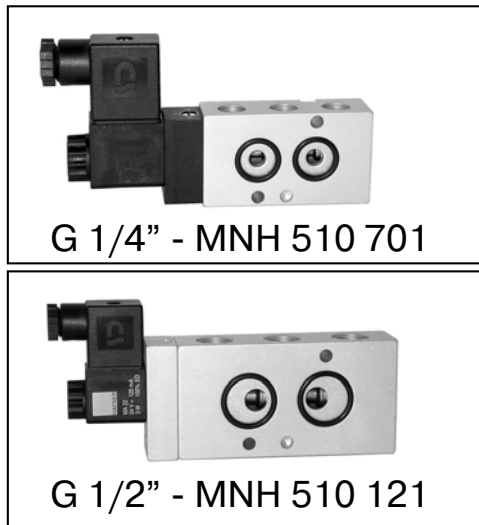

Notice: Difference between 1/4" – 1/8" and 1/2" – 3/8" is the air flow as well as the drilling depth of the fixing screws in the actuator. Therefore the valves to be used are the same, for G 1/8" and **G 1/4"** respectively G 3/8" and **G 1/2"**.

T	D1 (mm)	D2 (mm)	M (mm)
1/4" (1/8")	32	24	M5
1/2" (3/8")	45	40	M6



Single solenoid and single pilot valves are available with air spring or combined (air and mechanical spring) return.

**Valves with air spring return**

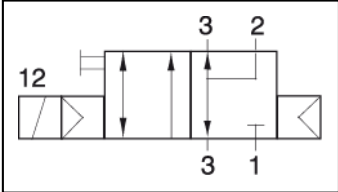

MNH 310 701

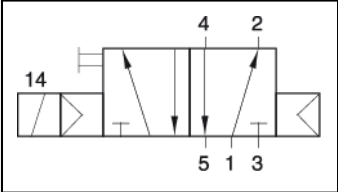

MNH 510 701

**Valves with combined spring return**

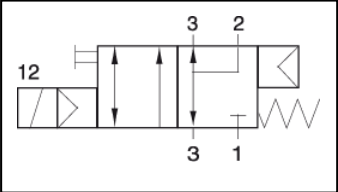

MNH 311 701

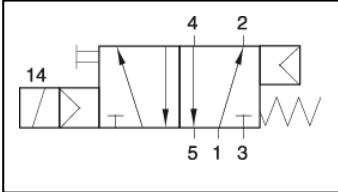

MNH 511 701

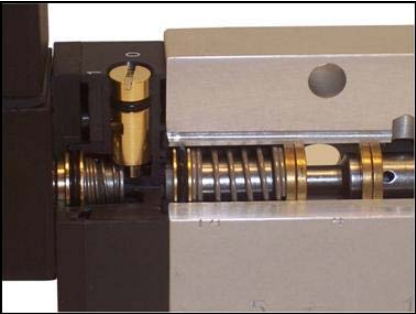
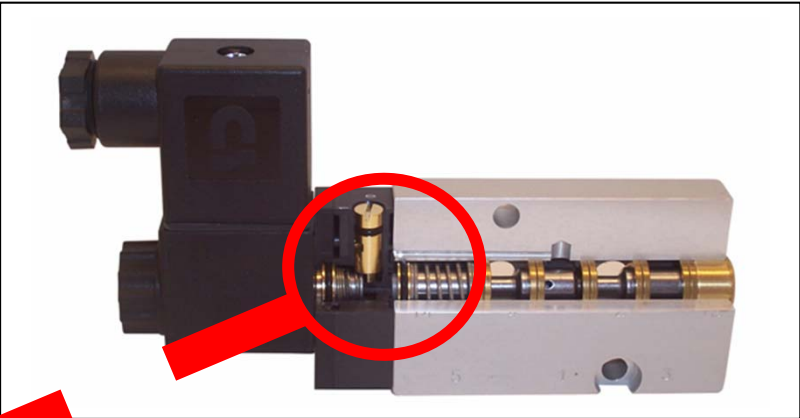

Combined spring assures a **fail-safe function** in case of loss of air pressure. Also available in the **G 1/2" standard**.



For single solenoid valves we offer two different port-schemes. Use depends on actuator interface.

2 port-schemes for 1/4" products

standard port-scheme

alternative port-scheme

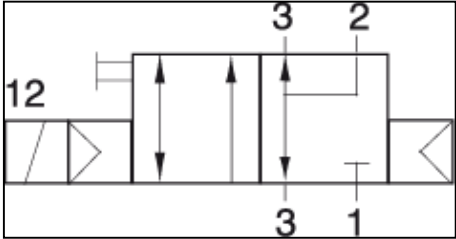

MNH 310 701

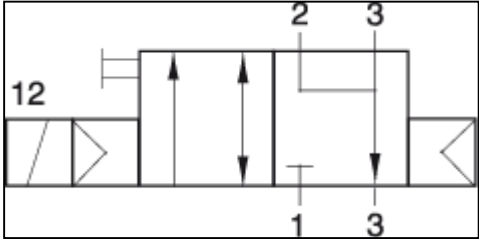

MNH 310 711

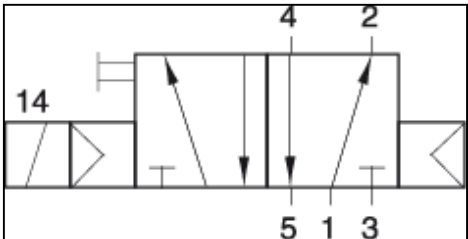

MNH 510 701

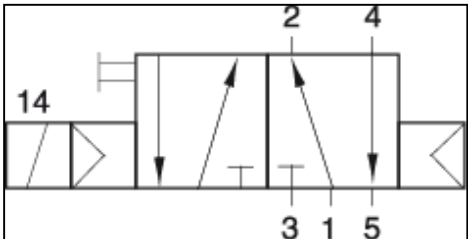

MNH 510 711





**The head (pilot part) of our Namur solenoid valves can be turned by 180° to ensure an high level of accessibility to the manual override.**

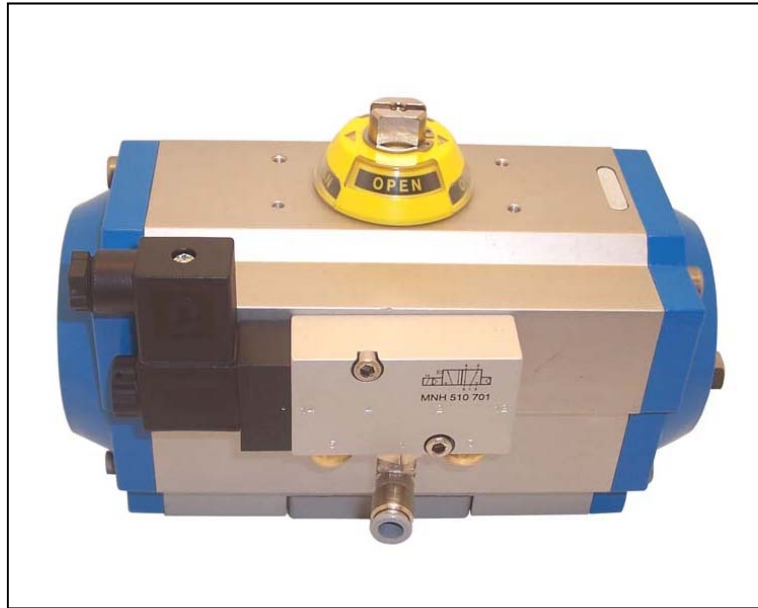

Standard MNH 510 701 mounted on a double acting actuator. The override is on the same side as the fittings.

Available Overrides:

Standard override **MNH**: manual, turn by screw-driver to operate

Alternative override **MND**: manual, momentary, push to operate

Alternative override **MNF**: manual, turn by hand to operate

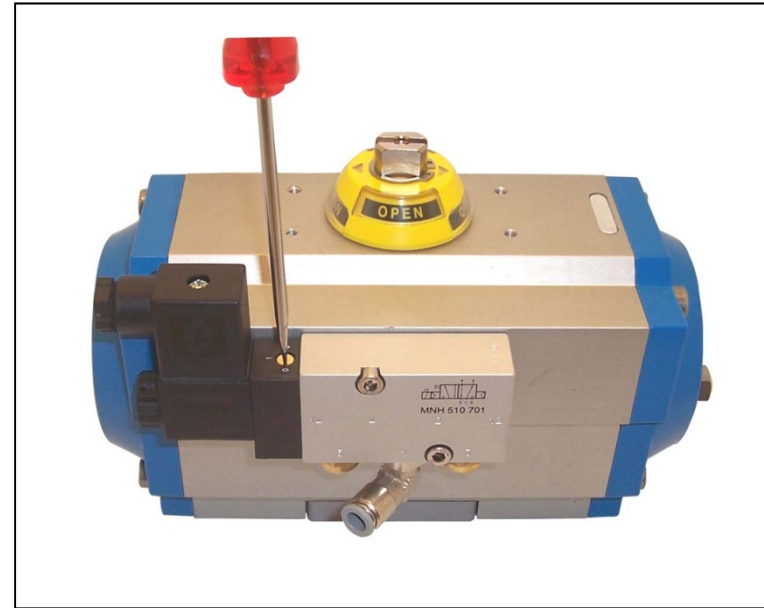

MNH 510 701 H180 mounted on a double acting actuator. The pilot part is turned by 180°. The override is on the other side from the fittings.

**Advantage:** Better accessibility



## Hafner NAMUR Flex – an innovative system to convert a 5/2-way into a 3/2-way valve with air recirculation.

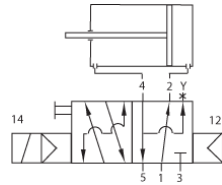
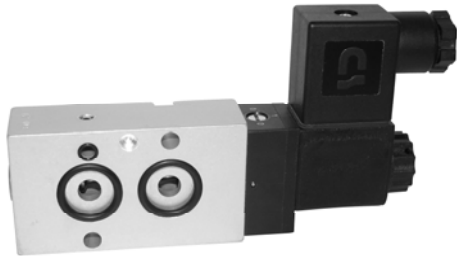

The Hafner **MNH 350 701** is a single solenoid 5/2-way valve with air-spring return to control a double acting rotary actuator. Interface in accordance to Namur 1 VDI/VDE 3845. Adding the “**Flex-Pack**”, converts the valve into a 3/2-way-Namurvalve with exhaust-air recirculation (“purge”).

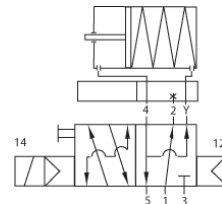

Instead of the Flex-Pack the „**Flex-regulator**“, converts the function of the valve and offers the possibility to control opening- and closing-speed of a spring-return actuator independently.

A valve with combined spring return is also available.

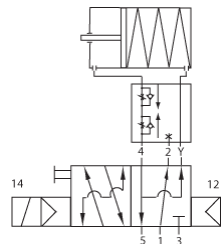
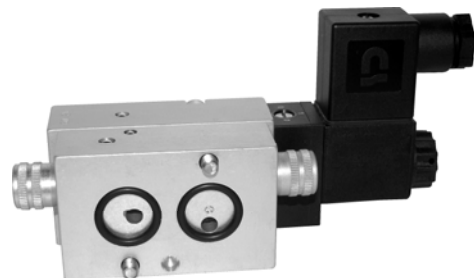

ATEX approved versions, low temperature versions as well as stainless steel versions are available.

## The Hafner NAMUR Flex can also be offered made of Stainless Steel

Hafner basically distinguishes between two different versions:

1. **VES** = valve entirely made of 316L / 1.4404 stainless steel
2. **KES** = valve body made of 316L / 1.4404 stainless steel, pilot head made of PA



Parts of the valve	VES-version	KES-version
Valve body	316L / 1.4404	316L / 1.4404
Pilot head	316L / 1.4404	PA
Seals	PUR	PUR
Other rubber-parts	FKM	NBR

Conversion plate made of 316L / 1.4404 is also available, please ask for FP 701 VES.  
For further information regarding our Namur-Flex, please refer to page 10.

## The Hafner Series “Hafner on the Rocks” is offering valves for low temperature applications.

Hafner on the Rocks is using a totally different sealing system than the „Swimming O-ring, the advantages are:

- Useable in low temperature applications
- Almost wear-free
- Very low friction
- Working without lubrication

The following products with the 1/4“ Namur-Interface are available:

- 3/2-way valve
- 5/2-way single solenoid valve
- 5/2-way double solenoid valve
- 5/3-way valve
- Block form flow regulators for 3-way and 5-way valves

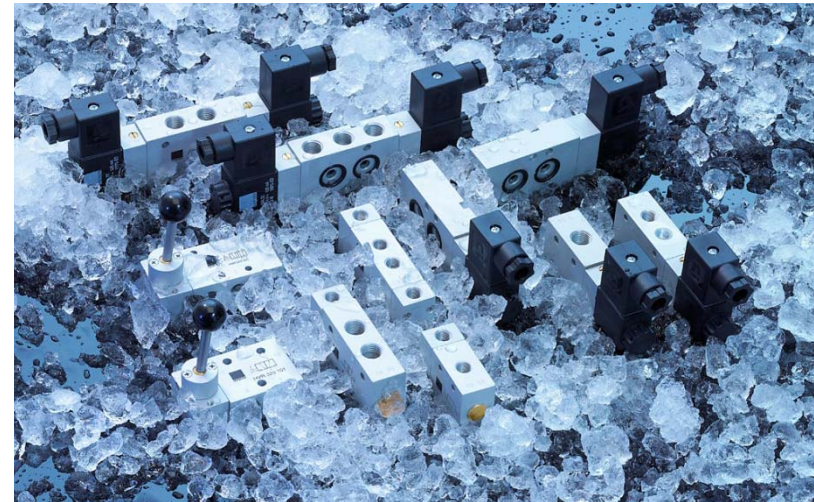

- **Designed and Manufactured for an environment from -50°C up to +50°C.**
- **Stainless steel versions available.**
- **ATEX approved versions available.**



**For further information please refer to chapter 2.9 in our valve catalogue 2012**

# The block form flow regulators are offering a very precise regulation.

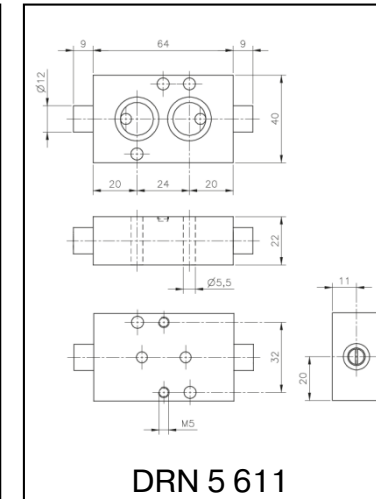
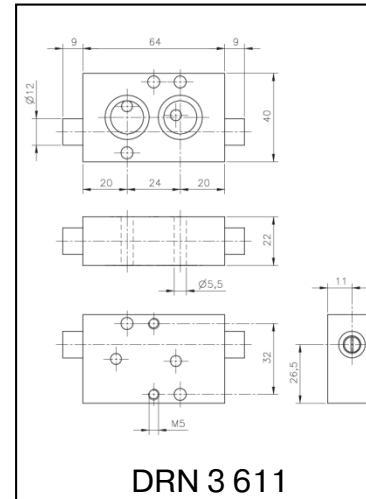
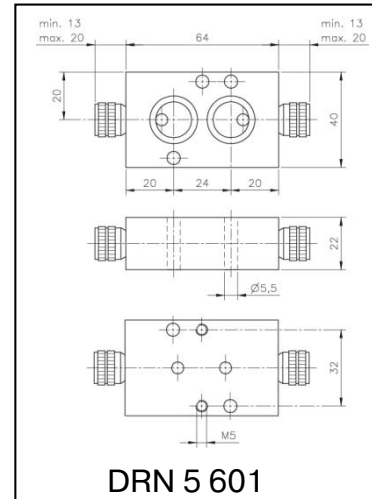
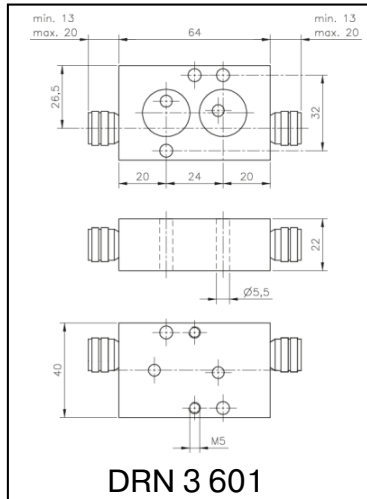
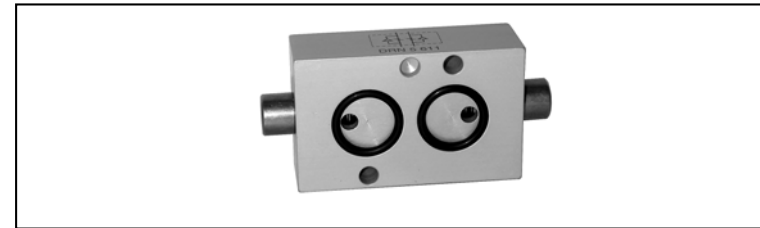

**NEW: DRN 3 128**



**Regulator for 3-way valves with 1/2" Namur-Interface**

- Regulation for **5-way** and **3-way** valves.
- Two **kinds of manipulation**, manual or with a screw-driver
- **Very precise regulation.**
- Only possibility to regulate the **forward-** and **backward-stroke** of a **spring-return actuator**, that is controlled by a 3-way valve **separately** and **precisely.**
- Interface according to **1/4" Namur** standard.

**Also available with G1/8" threaded ports!**

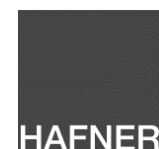
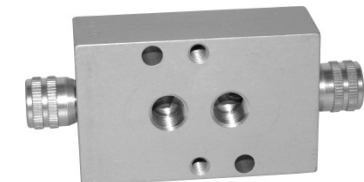

**With the plates ZVP Hafner offers a product to easily assemble cylinder-valve-combinations with Namur-valves.**



Hafner offers **four types of plates:**

Ported **G 1/4"** with an orifice-size of **7 mm** optimized to be used with the 700 series.

Ported **G 3/8"** with an orifice-size of **10 mm** optimized to be used with the 100 series.

Ported **G 1/2"** with an orifice-size of **12 mm** optimized to be used with the 121 series (Namur 2)

With **G 1/2"** banjo but for **interface Namur 1** (1/4"-standard).

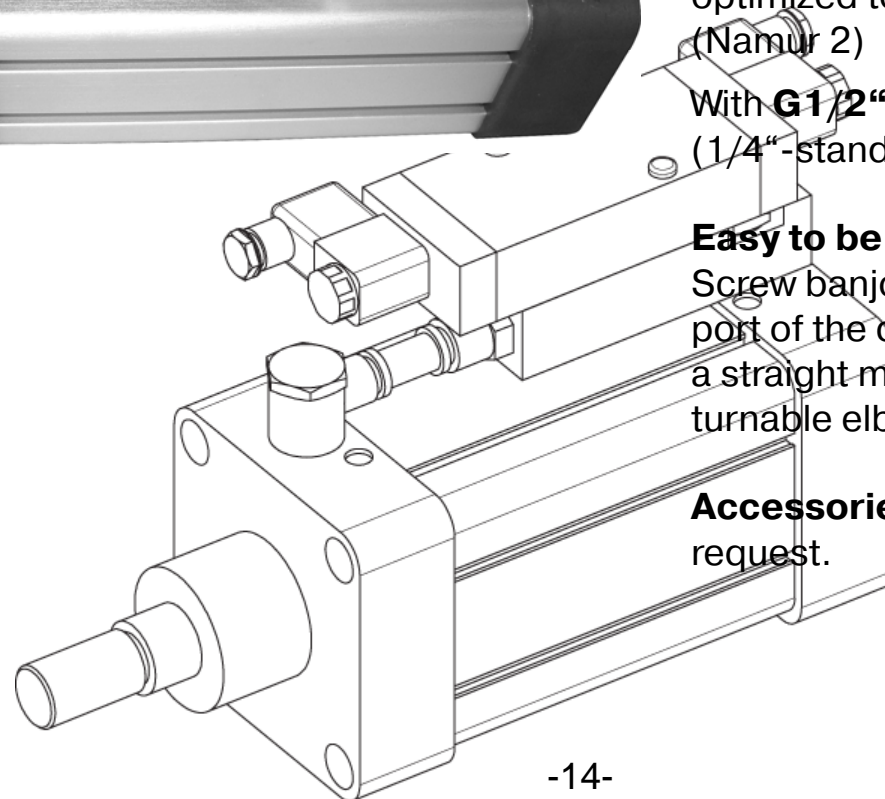

**Easy to be assembled:**

Screw banjo (part of the delivery) into one port of the cylinder. Connect other port using a straight male fitting into the plate), a turnable elbow fitting and a piece of tube.

**Accessories** can be supplied by Hafner on request.

# Air-recirculation block with Namur-Interface to ensure, that no ambient atmosphere sucks into a spring-return actuator.

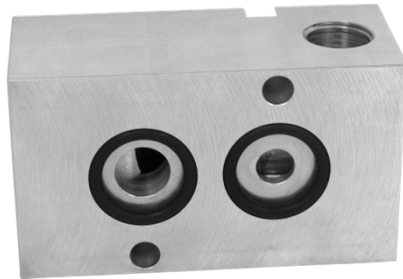

The **Hafner Namur Air-recirculation Block** absolutely guarantees, that only exhausting air from the actuation-side is going into the spring chamber and for sure no ambient atmosphere.

Especially been used for remote piloting (e.g. a valve which is assembled in a control cabinet).

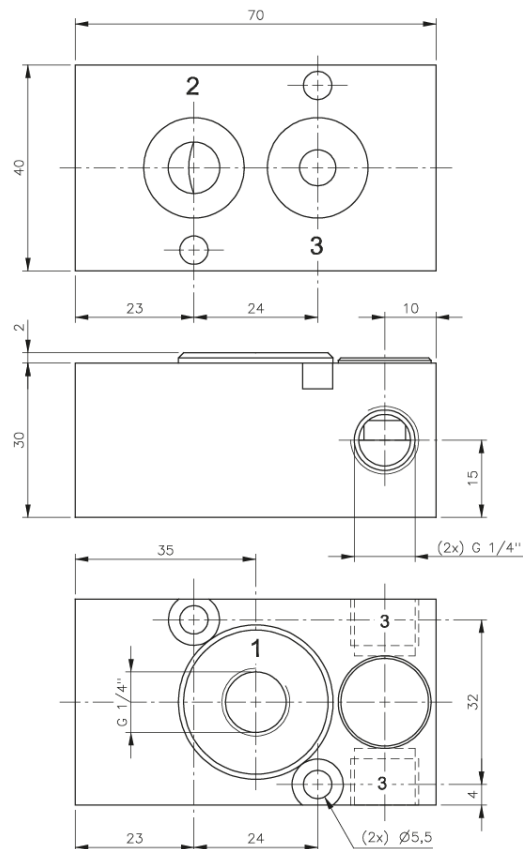

Valve is designed for **spring return** pneumatic actuators with an **1/4" Namur-Interface**.

Standard with a G1/4" pilot port.

**Stainless steel version** is available on request.

**Function:**

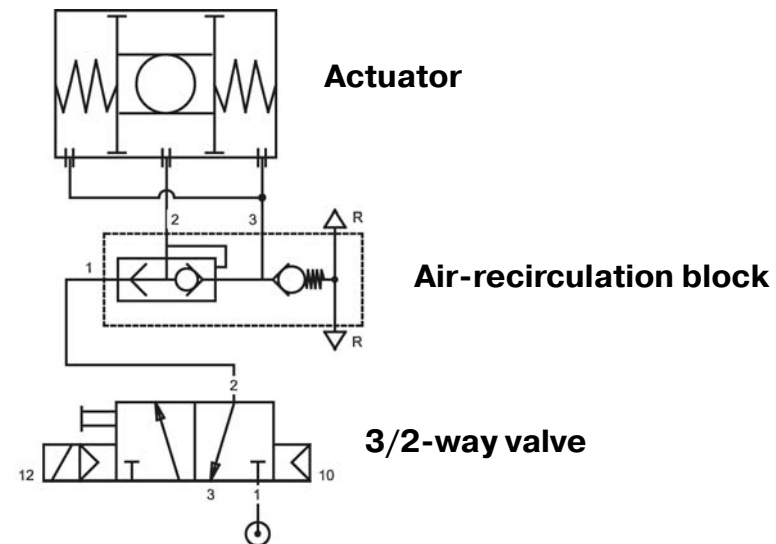

# A quick-exhaust block with Namur-Interface that allows even big actuators to close at high speed.



The **Hafner Namur Quick Exhaust Block** contains a **quick-exhaust valve** that allows even big actuators to close at high speed.

In addition the block contains a **non-return-valve** that absolutely guaranteed that only exhausting air from the actuation-side is going into the spring chamber and for sure no ambient atmosphere.

Valve is designed for **spring return** pneumatic actuators with an **1/4" Namur-Interface**.

Standard with a G1/4" pilot port. A version with a 1/4"-Namur interface so the customer can use a 3/2-way Namur-valve to pilot the block is available.

**Low-temperature-version** is available on request.

**G 1/2"** block currently being designed.

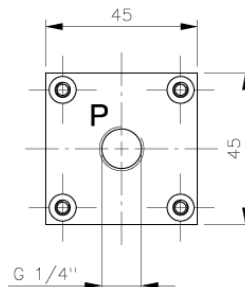
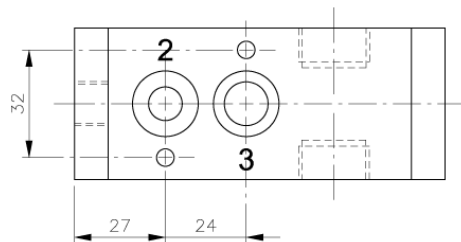
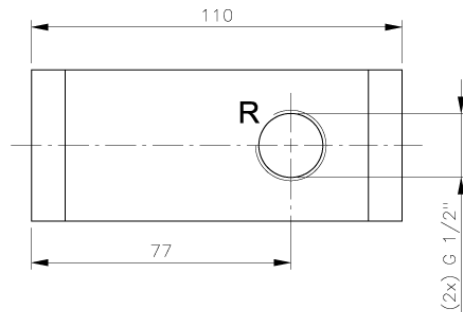
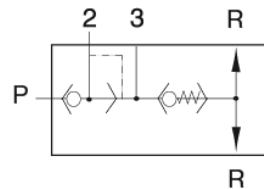



## Short circuit valves to ensure an easy closing by hand-wheel.

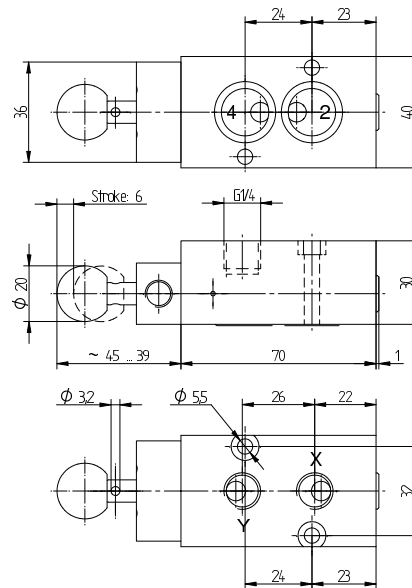
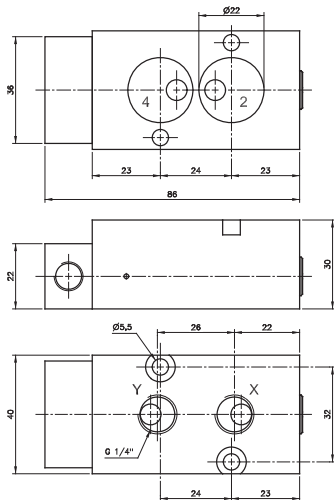
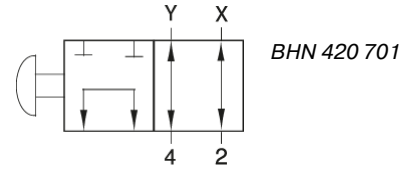
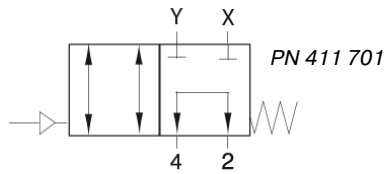
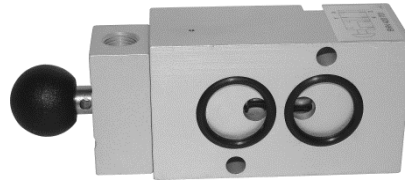
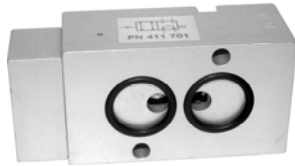

The **PN 411 701** and **BHN 420 701** is made for direct assemblage to an actuator with 1/4" Namur interface. It offers a 1/4" Namur interface towards the pilot-valve (use as sandwich plate) as well as G 1/4" ports (piped application).

### Function PN 411 701:

As long as a pneumatic signal is applied, the valve forwards the signals applied to 2 and 4 through to X and Y. When no pneumatic signal is applied the ports 2 and 4 are shortcut.

### Function BHN 420 701:

When the button is pulled, the valve forwards the signals applied to 2 and 4 through to X and Y. When the button is pushed, the ports 2 and 4 are shortcut.

### Typical application:

Automated process-valve equipped with a gear-box for manual actuation. In case of a failure, the valve ensures, that the user doesn't have to close the process valve against the force of the air, which is usually trapped in the actuator.

*G 1/2" threaded high-flow version available on request.*



# Hand-lever valves with safety function when a positioner is used.

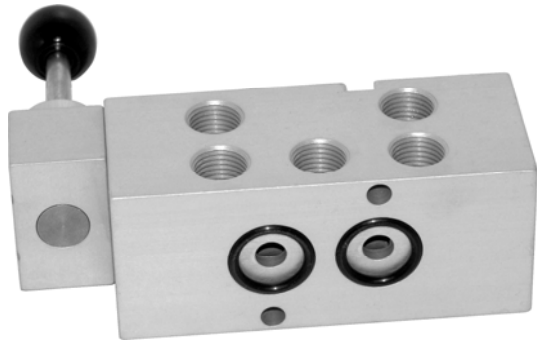

Hand-lever valve for direct assemblage to an actuator with 1/4" Namur interface.

Offers safety function when a positioner is used.

### Version 731 701:

Normally the lever is in the middle position and the actuator is piloted by the positioner. In this position the valve just feeds the signals from the positioner through to the Namur-ports.

In case of electric / electronic problems the actuator can be opened or closed manually.

Advantages of version 701:

Only one lever to manipulate (not 2 actuation elements). Overrides in manual mode the positioner, manual mode and automatic mode truly independent.

### Version 731 702:

If the knob is pushed, air flows from the positioner from Y to 4 and from X to 2.

If the knob is pulled the positioner is shut-off.

The lever valve is to be used as a centre closed 5/3-way valve, actuator can be fully opened, fully closed or put into intermediate position.

Advantage of version 702:

Offers in manual mode a centre closed 5/3-way valve, version 701 is in manual mode 5/2-way.

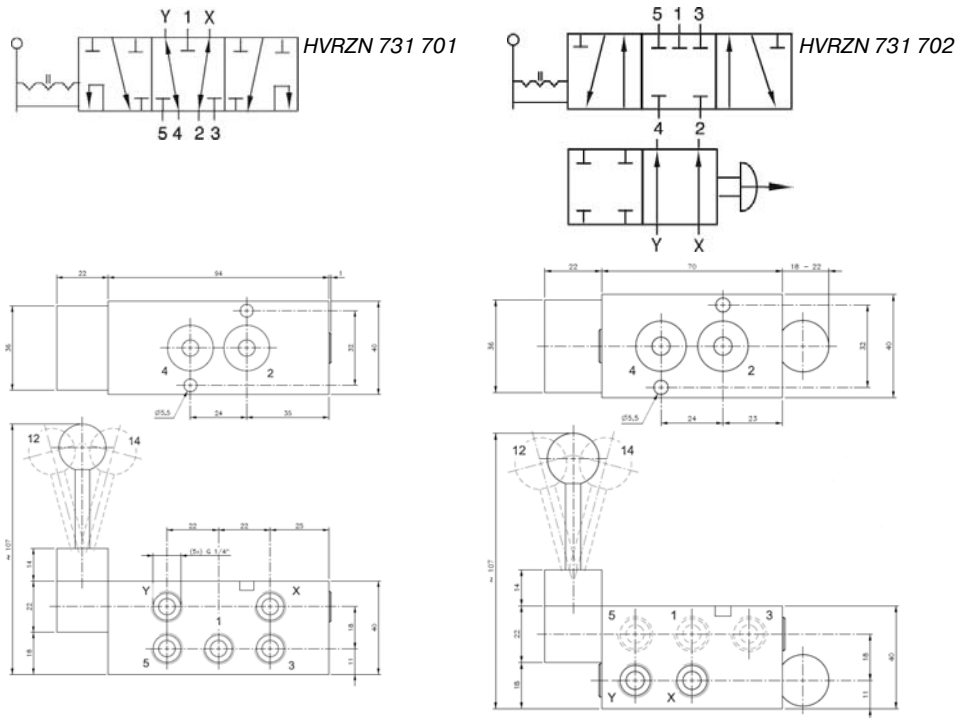

In order to avoid unintended manual actuation the lever of both versions has to be pulled thoroughly for being manipulated!



## Pressure applied safety valve with Namur-Interface.

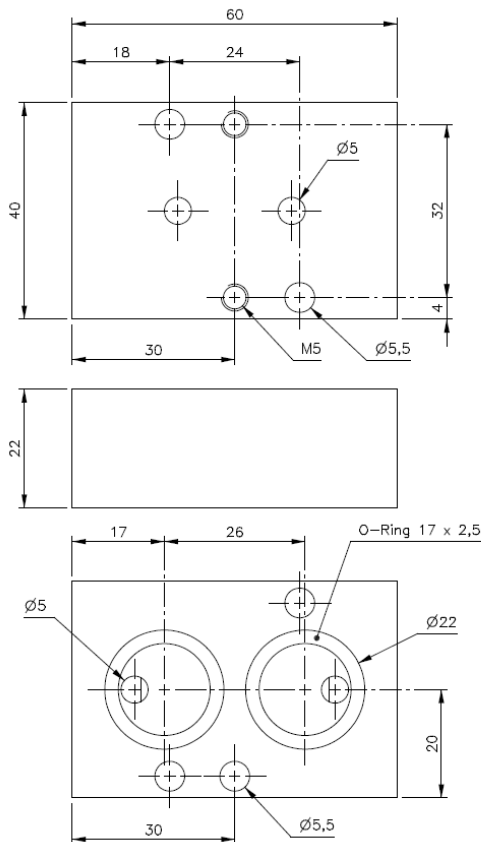
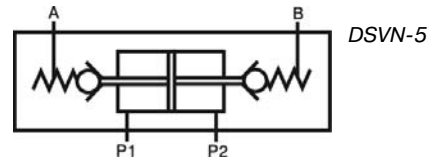

The DSVN-5 is a pressure applied safety valve to hold a double acting actuator at the current position in case of cut-off of pressure supply.

The valve is consisting of two non-return valves which will be unlocked by pressurising port P1 or P2.

Installation between pilot valve and actuator.

Interface according to 1/4" Namur standard.

A special plate with G 1/4" BSP threads for remote piloting can be supplied on request.

Inner parts are made from brass and POM, seals are made from NBR.

Temperature range: -10° C to +70° C.

# Block and vent valve for on site servicing of the armature.

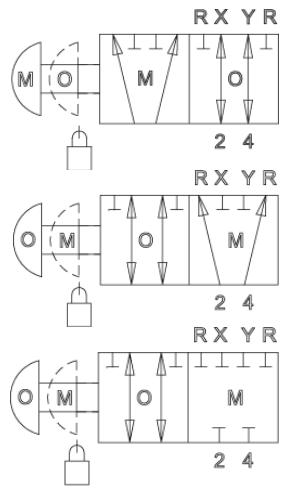

BHN 601

BHN 601 01

BHN 611 01

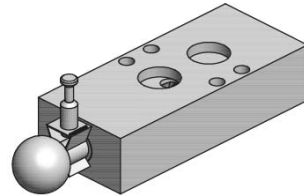

The **BHN 601** is made for blocking the air supply from the pilot valve to the actuator and venting at the same time both actuator chambers. The valve offers a locking function in the O-position.

The **BHN 601 01** has the same function as the BHN 601. Locking function is in the M-position. In addition the valve has a pin to fix the valve in the O-position.

The **BHN 611 01** is made for blocking the air supply from the pilot valve to the actuator and holding the actuator in the current position. The valve offers a locking function in the M-position. In addition the valve has a pin to fix the valve in the O-position.

O-Position = Normal Operation  
M-Position = Maintenance

These valves are mainly being used where on site servicing of the armature is required and during service, the actuator needs to be isolated from the control system.

Typical application for BHN 611 01:  
Valves for filling tanks to protect people cleaning the tank.

Valves can be used on single acting and double acting actuators.

Interface according to 1/4" Namur standard.

A special plate with G 1/4" BSP threads for remote piloting can be supplied on request, type GPN 1/4. Lock is not part of the delivery content.

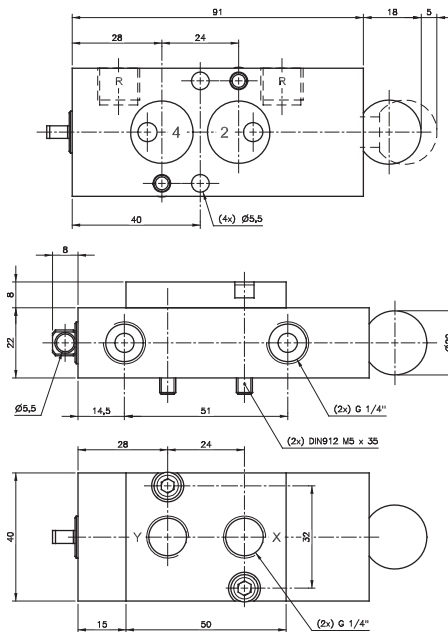

BHN 601

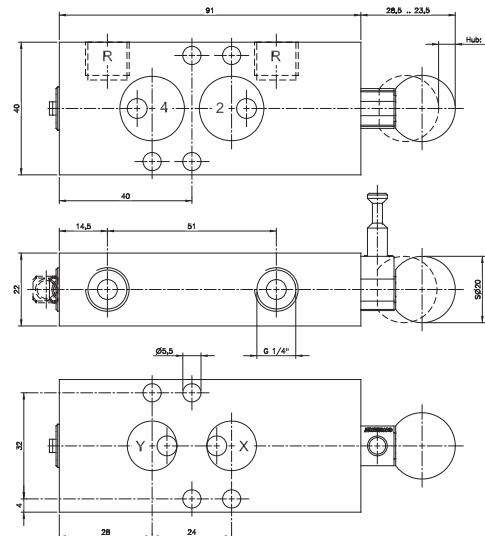

BHN 601 01 / BHN 611 01

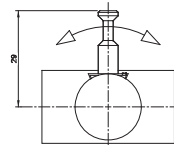

## Solenoid valve to achieve a “fail-in-place” position of the actuator.

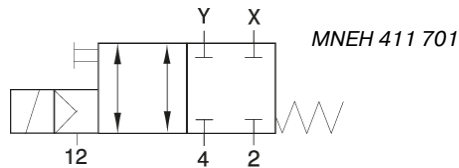

MNEH 411 701

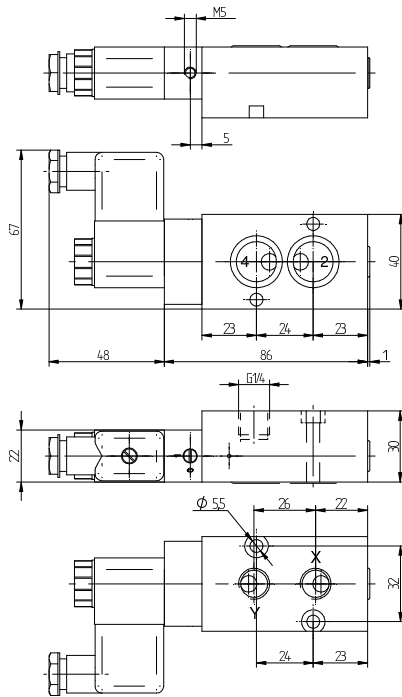
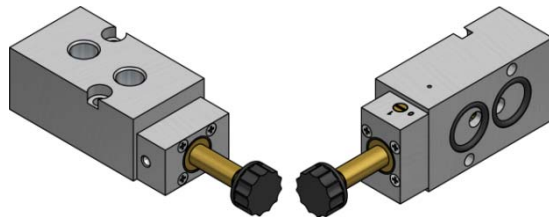

The MNEH 411 701 is made for blocking the air supply from the pilot valve to the actuator and holding the actuator in the current position.

It is designed for direct assemblage to an actuator with 1/4" Namur interface.

It offers a 1/4" Namur interface towards the pilot-valve (use as sandwich plate) as well as G 1/4" ports (piped application).

### Function :

As long as an electric signal is applied to the solenoid as well as air pressure is applied to the external pilot port, the valve forwards the signals from the pilot valve which are applied to 2 and 4 through to X and Y.

All ports are blocked when the electric signal or air pressure at the external pilot port cut off.

Available with solenoid operators:

230V/50Hz, 100V/50Hz, 24V/50Hz, 48V=, 24V=, 12V=.

Valve is equipped with a manual override.

### Please notice:

**external pilot feed is required!**



## Valve for two speeds, speed of actuator can be reduced when process valve is moving into the seal. Signal from switch-box required.

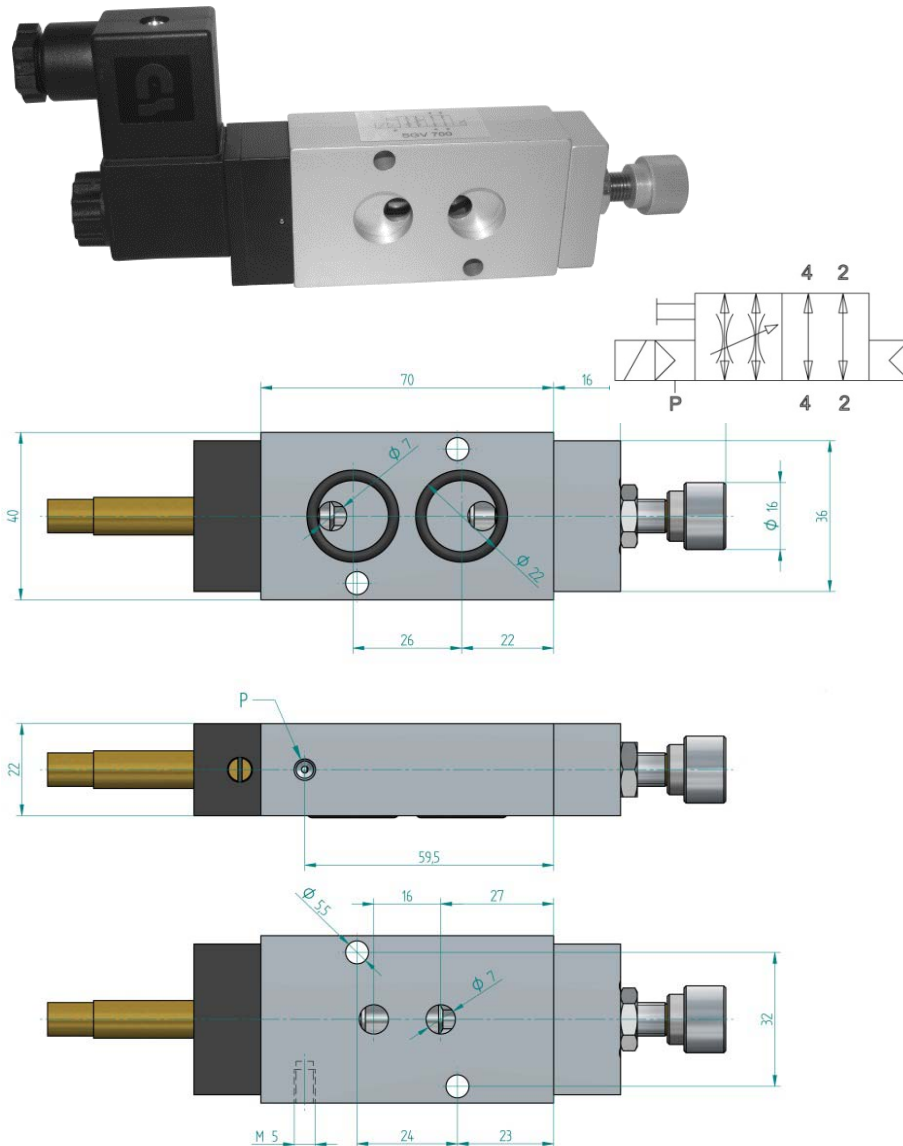

Two-speed valve to operate a pneumatic actuator at two different speeds.

This ensures a smooth closing and, if requested, a smooth opening of the process valve.

### Function:

When the valve is switched-off the air streams through the valve without any restriction.

When the actuator reaches a defined angle e.g. 5° the solenoid gets a signal from the switch-box (additional electric switch required) to actuate it.

This restricts the air-flow. The flow can be regulated by turning the spindle at the back of the valve.

To open you have the choice whether to keep the restrictor active = solenoid energized until actuator reaches a certain angle (again) or if you want to open at full speed = switch-off the valve.

The valve is designed to go as a sandwich between actuator and Namur-pilot-valve. External piping is possible with our GPN-1/4 threaded plate.

The valve needs an external air supply, port P (M5).



# The Controlblock CBN 700 for process-valves with inflatable seal controls the actuator as well as the in- / deflation of the seal.

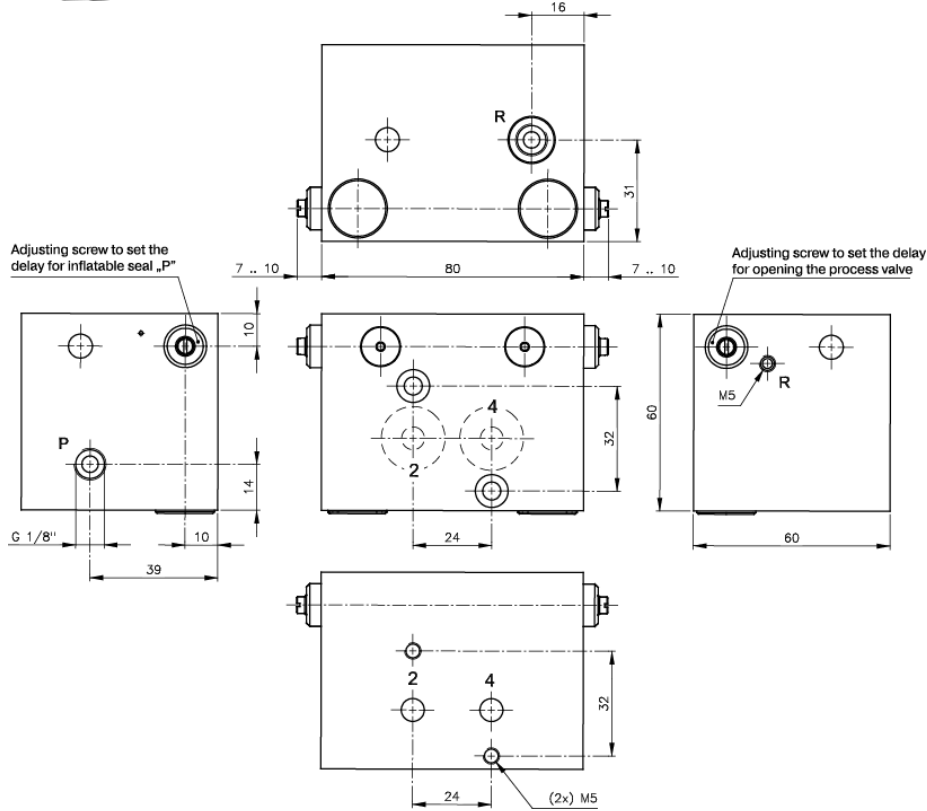

**Controlblock for double acting actuators with 1/4" Namurinterface to be used on process-valves with inflatable seal.**

The control-block receives it's signals to open and close from a standard 5/2-way Namurvalve. The block is to be put between the actuator and the Namur-valve (flange-version).

The closing-signal is fed through to the actuator, the seal is inflated with time-delay. When the process-valves is to be closed first the seal is deflated, with time-delay the actuator opens the process-valve. Opening- and closing-time-delay can be adjusted independantly but they are related to the operating pressure. At 6 bar time-daly can be adjusted between 0 and 2 seconds.

**Temperature-range: -40°C bis +50°C**

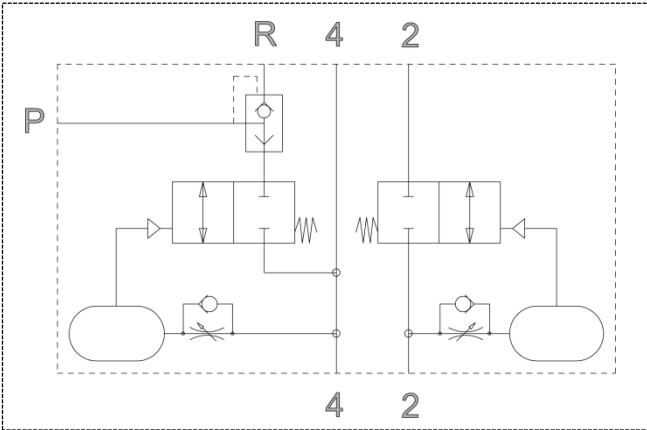

## Various plates are enlarging our Namur-range.

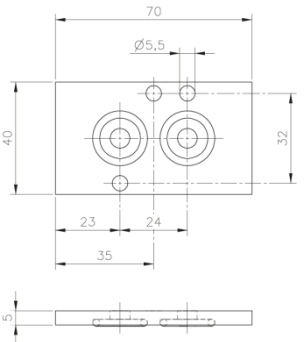
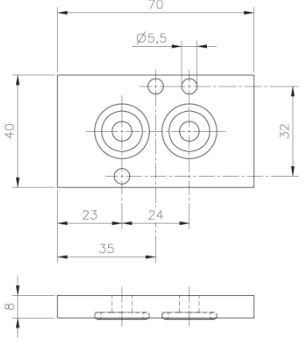
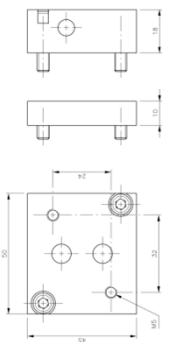
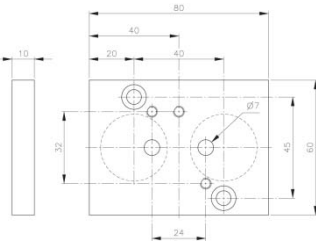
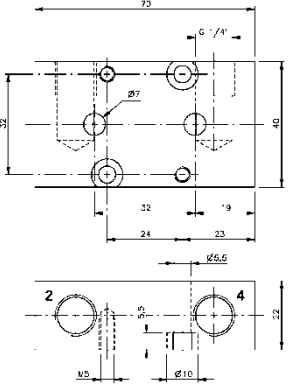
Type ZPN 5	Type ZPN 8	Typ ZPN 701 90	Type ZPN 6-10	Type FPNW 22-1/4
<p>Intermediate plate to be used in case a 30 mm wide coil (e.g. EEx i.a.) is to be assembled to a 22 mm wide G 1/4" Namur-valve.</p>	<p>Intermediate plate to be used in case a 36 mm wide coil is to be assembled to a 22 mm wide G 1/4" Namur-valve.</p>	<p>Two-piece plate to turn the Namur-interface on the actuator by 90° assuring a full orifice-size of 7 mm.</p>	<p>Adapter plate to be used in case a G 1/4" Namur valve is to be assembled to a G 1/2" actuator flange.</p>	<p>Conversion plate to convert a 5-way Namur-valve into an inline valve. The Namur ports 2 and 4 are transferred into the plate and offer G 1/4" BSP thread. The plate can be assembled independently and the valve is attached later-on.</p>
				

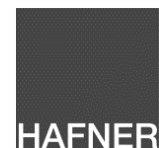
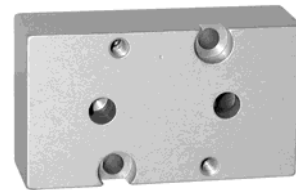
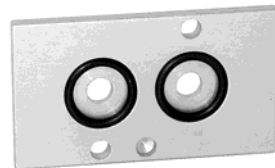
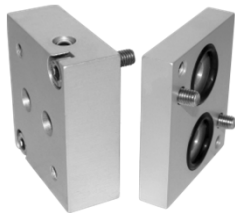



**Direct-actuated 3/2-way pilot-valves e.g. for small actuators of angle-seat-valves are displayed in the catalogue.**

**22mm wide with 50 l flow**

**30mm wide with 300 l flow**

**Low temperature & ATEX version available.**



Port 1: G1/8"  
 Port 2: G1/8" or G1/4" as banjo  
 Port 3: M5

Port 1: G1/8"  
 Port 2: G1/8" or G1/4" as banjo  
 Port 3: G1/8"

Valve using the standard 22 mm solenoid system available in voltages 12VDC, 24VDC, 48VDC, 24VAC, 110VAC, 230VAC, version for explosion hazardous environment available.

Valve using a 30 mm integrated solenoid system, currently available as 24VDC, 24VAC and 230VAC to come soon.





Further technical information on page 69 & 177 of the valve-catalogue edition 2011.

Further technical information on page 70 of the valve-catalogue edition 2011.

**New in 2012:  
 Valves with body made from Polyamide**



## Many Hafner products are available in versions for explosion-hazardous environment.

Valve Body	Temperature	Protection			
		Ex na (non-sparking)	Ex ia (intrinsically safe)	Ex m (encapsulation with cable)	Ex e mb (encapsulation with junction box)
					
Aluminium	-10° C to +50° C	✓	✓	✓	✓
Stainless Steel	-10° C to +50° C	✓	✓	✓	on request
Aluminium	-40° C to +50° C	not available	✓	not available	✓
Stainless Steel	-40° C to +50° C	not available	✓	not available	on request

When these solenoid systems are used in combination with “ATEX certified” mechanical components conforming EN 13463-1:2001 and PrEN 13463-5:2000, the entire valve can be used in explosive hazardous environment **zone 1 and 21**.

A presentation of ATEX-approved products for explosion hazardous environment is available on request.



The Hafner philosophy is to fulfill specific customer requirements  
 (1) → G 1/4" valves with maximum flow

**Our Series 101 supports you with a flow of 2.250 l/min**

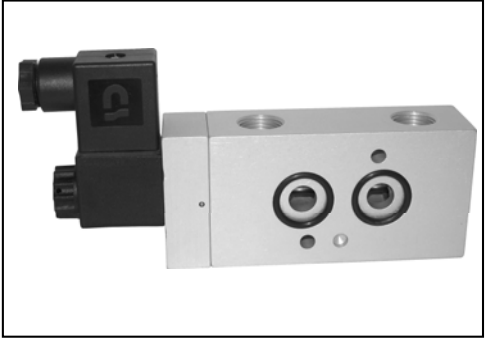

MNH 310 101

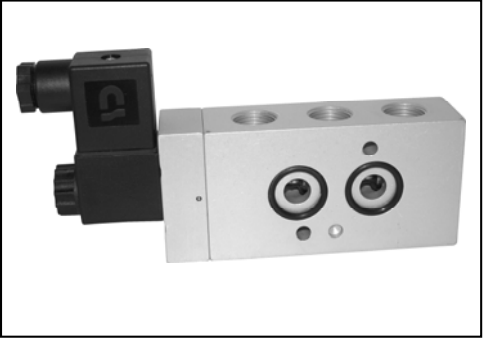
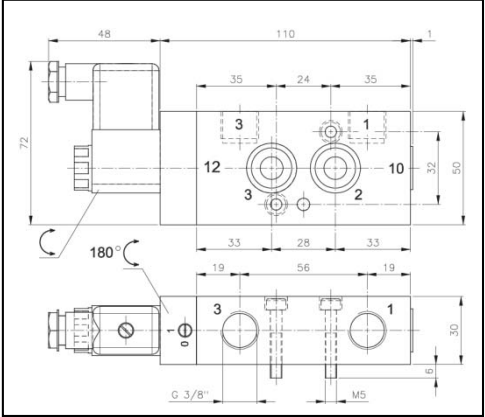

MNH 510 101

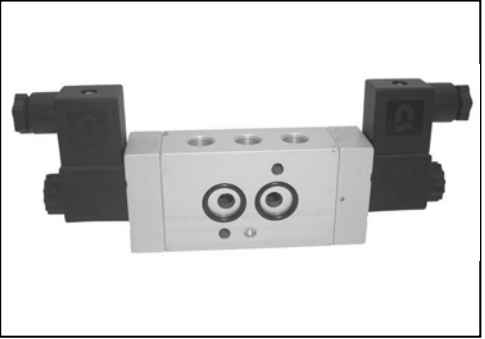
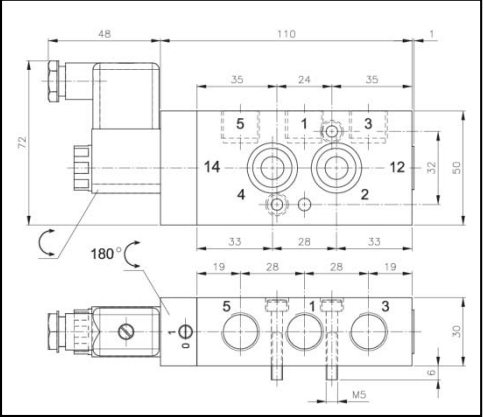

MNH 520/531 101

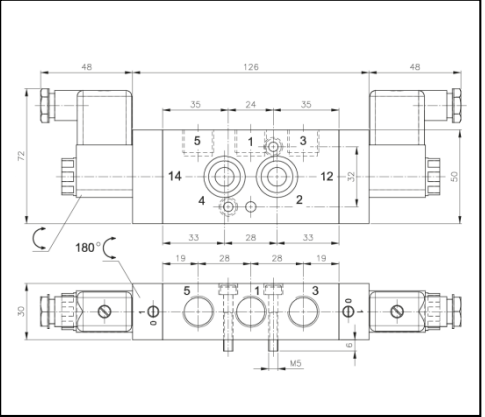

The Hafner philosophy is to fulfill specific customer requirements  
 (2) → G 1/4" valves with high flow

Our Series 801 supports you for the connection G 1/4" with a high flow of 1.500l/min



MNH 310 801

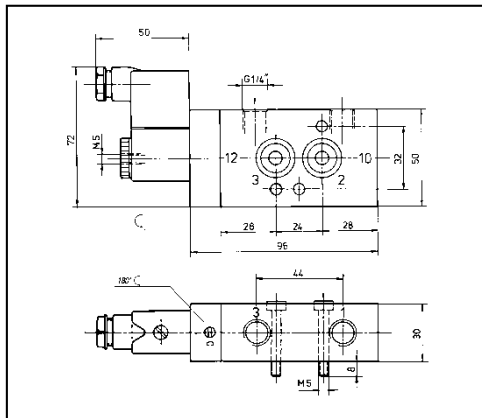

MNH 510 801

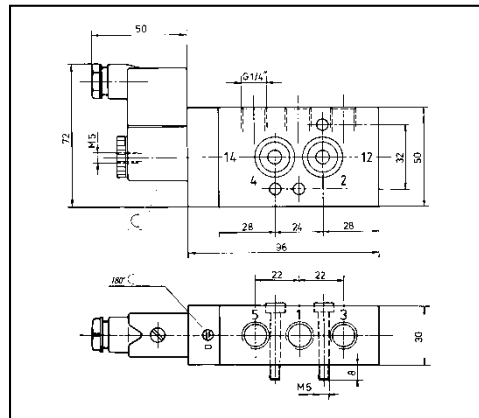

MNH 520/531 801

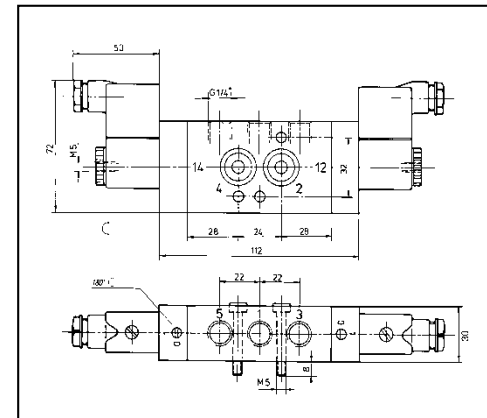

The Hafner philosophy is to fulfill specific customer requirements  
**(3) → Non-standard range 401**

**Our compact series 401 is specially designed for smaller actuators.  
 (Please take note: The series 401 is in accordance with the Namur standard).**

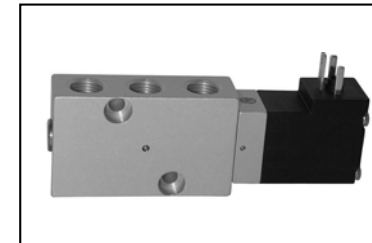
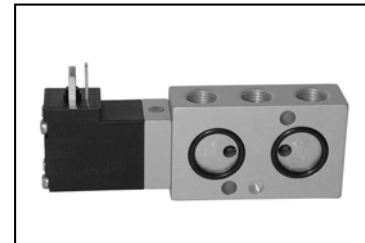
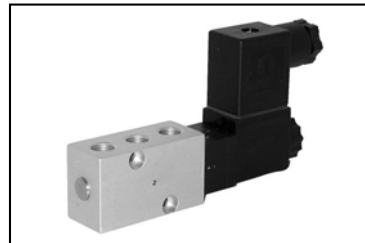
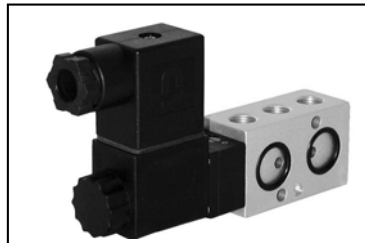

MNH 510 401

MND 510 401

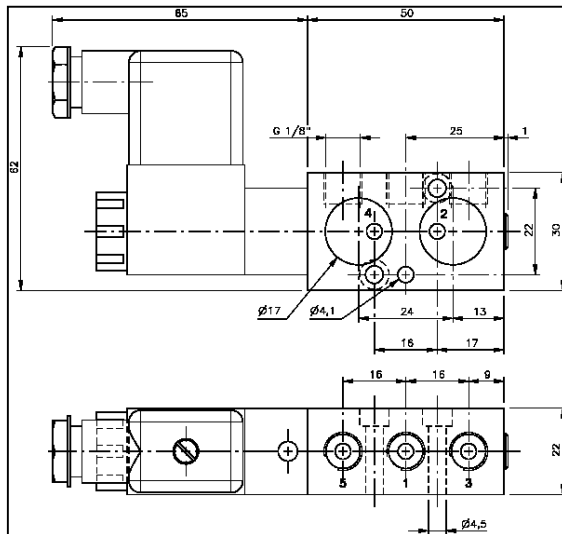

Ports in accordance to G 1/8" standard.  
 Fixing holes non-standard.

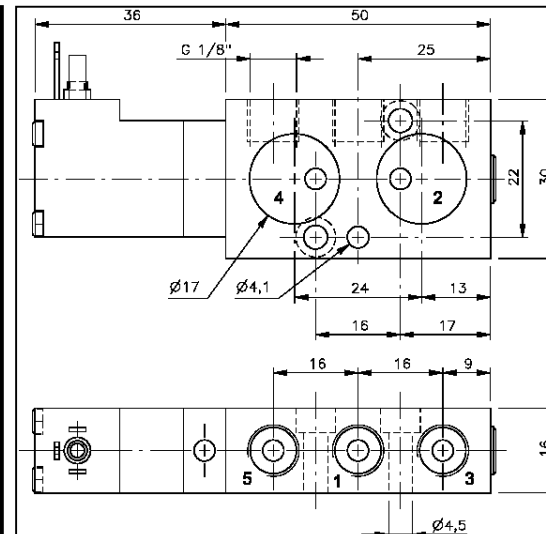

## The Hafner philosophy is to fulfill specific customer requirements (4) → Low Power Consumption 1.8 W / 3 VA

In order to combine high flow with low power consumption we developed the MNK series. It is a combination of the 1.8 Watt / 3.0 VA solenoid-system MA 16 and the G 1/4" valves of the 700-series with a flow of 1.250 NL/min.

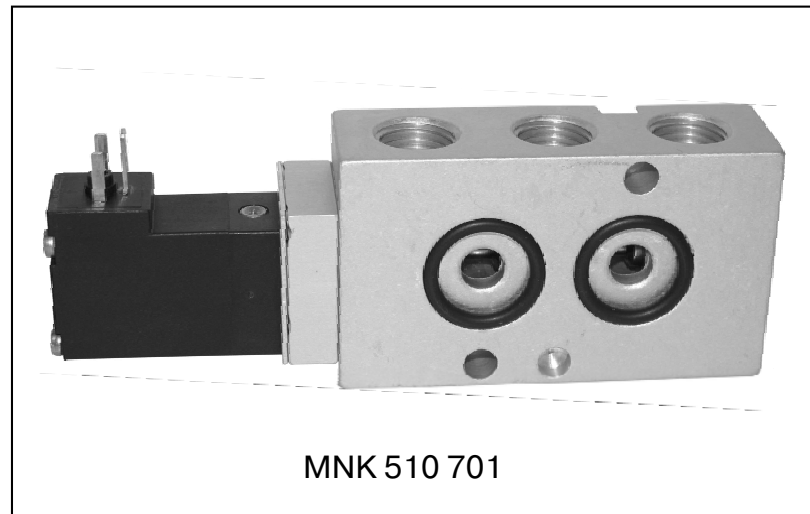

These valves can be used e.g. with ASI-BUS switch-boxes.



Our target is to satisfy the demand for spool valves with:

- **High Flow**
- **Compact Design**
- **Low Power Consumption**

**The Hafner philosophy is to fulfill specific customer requirements  
(5) → Brass free products**

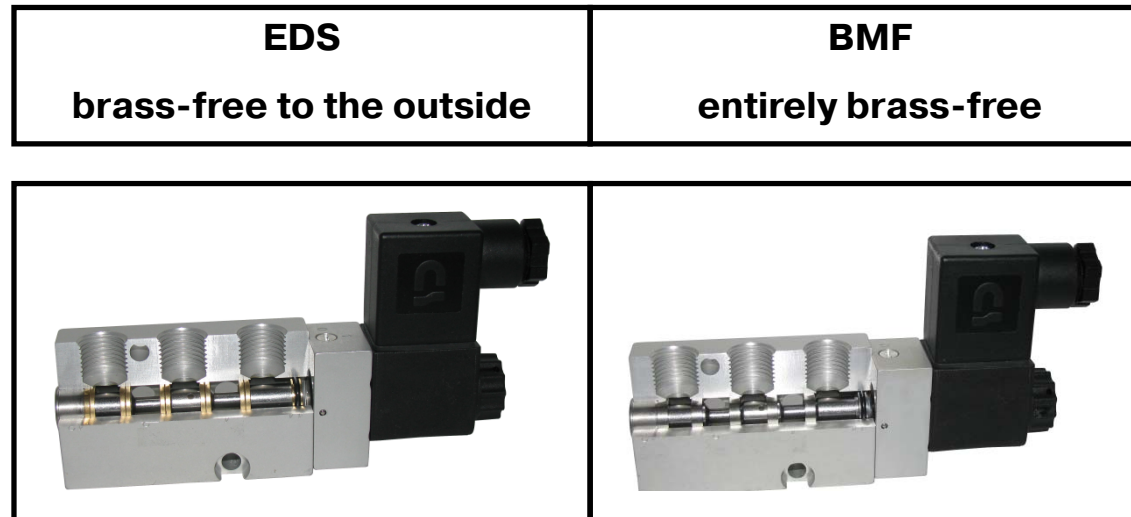

<b>Parts of the valve</b>	<b>EDS version</b>	<b>BMF version</b>
Valve body	Aluminium	Aluminium
Pilot head	Aluminium	Aluminium
Manual override	Stainless steel	Stainless steel
Operator tube	Stainless steel	Stainless steel
Seat below plunger	Brass	Stainless steel
Piston	Brass	Stainless steel
Spool	Stainless steel	Stainless steel
Cages for seals	Brass	Stainless steel
Seals	NBR	PUR
End cap	Stainless steel	Stainless steel

## The Hafner philosophy is to fulfill specific customer requirements (6) → Hard coated products

Hafner has the possibility to offer products that are hard coated (hard anodized) on request.

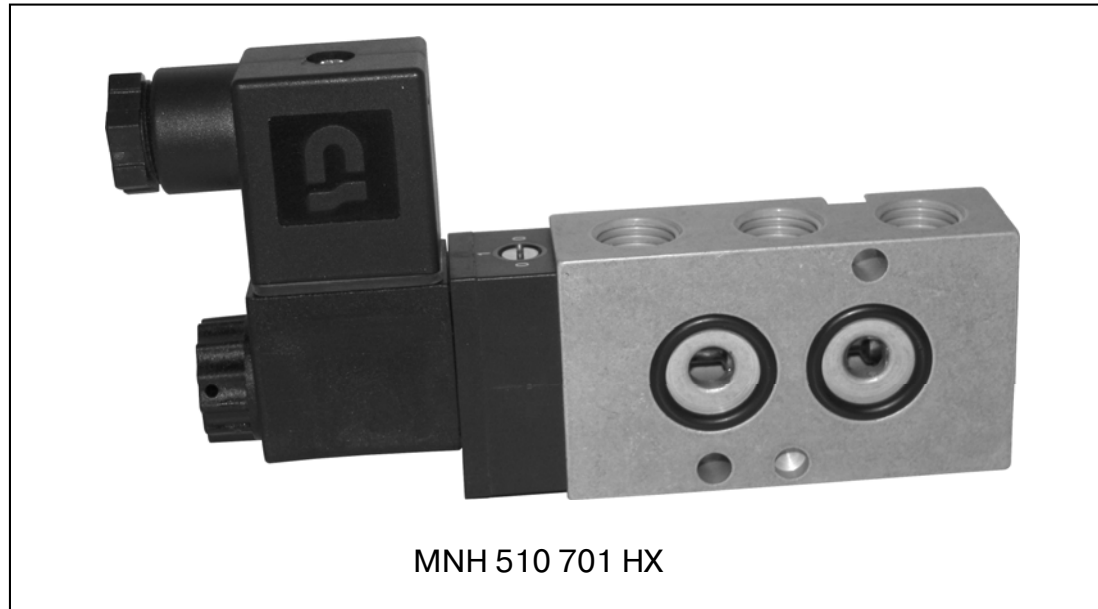

- Products can be used in **the food-industry**.
- Valves can be made in “**EDS = brass-free to the outside**” version.



**The Hafner philosophy is to fulfill specific customer requirements  
(7) → Namur-Valve for actuators with vertically orientated ports**

**The MNH 510 706 gives you the possibility to turn the valve by 90°. It allows to assemble the valve horizontal even so ports at the actuator are vertically orientated.**



MNH 510 706

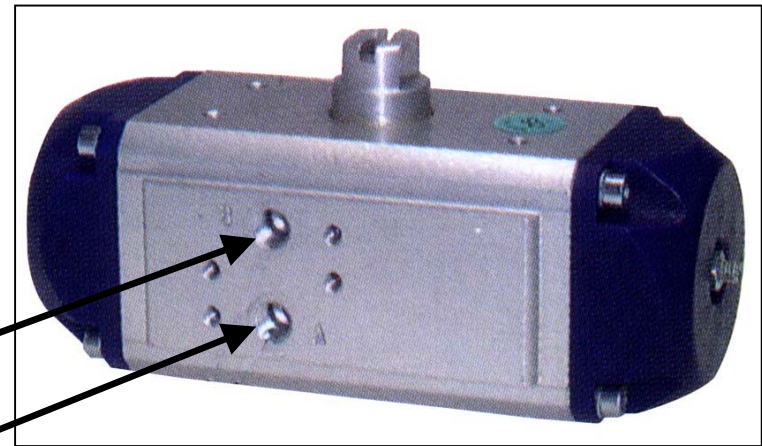

Actuator with vertically orientated ports

Hafner-Pneumatik Krämer KG  
Stammheimer Straße 10

D-70806 Kornwestheim

Phone +49 – 7154 – 17 85 89 0  
Fax +49 – 7154 – 17 85 89 28

[info@hafner-pneumatik.de](mailto:info@hafner-pneumatik.de)  
[www.hafner-pneumatik.de](http://www.hafner-pneumatik.de)

Hafner Pneumatika Kft.  
Püski út 3.

H-9228 Halászi

Phone +36 – 96 – 57 30 12  
Fax +36 – 96 – 21 06 15

[ertekesites@hafner-pneumatika.com](mailto:ertekesites@hafner-pneumatika.com)  
[www.hafner-pneumatika.com](http://www.hafner-pneumatika.com)