



Tel: +44 (0) 1706 869777
E-mail: sales@desal.co.uk
Web: www.desal.co.uk



User manual

Installation, Operation and Maintenance Manual

APP pumps (APP 0.6-1.0)



APP 0.6-1.0

Table of Contents

Validity.....	4
EU Declaration of Conformity.....	5
1. Introduction.....	6
1.1 General.....	6
1.2 Symbols.....	6
1.3 Manufacturer and customer service address.....	6
2. Safety.....	7
2.1 General information.....	7
2.2 Preferred system design.....	7
2.3 Commissioning and servicing the unit.....	7
2.4 Adhere to the following important points.....	7
2.5 In case of doubt.....	7
3. Technical data.....	8
3.1 Approved applications and operational limits for the pumps.....	8
3.2 Application range.....	8
3.3 Electric motor data.....	8
3.4 Noise and vibration.....	8
3.5 General arrangement.....	8
3.6 Space requirement.....	8
3.7 Filtration.....	8
3.8 Properties of water.....	8
3.9 Air bubbles.....	8
3.10 Chemicals.....	8
4. Arrival inspection, transportation, handling, lifting and storage.....	9
4.1 Arrival inspection.....	9
4.2 Warning.....	9
4.3 General safety information.....	9
4.4 Transport and handling.....	9
4.5 Return to supplier.....	10
4.6 Storage.....	10
5. Installation and commissioning.....	11
5.1 Important dimensions.....	11
5.2 Cleanliness.....	11
5.3 Fluid temperature.....	11
5.4 Electrical data.....	11
5.5 Local regulations.....	11
5.6 Pre mounting checklist, based on Danfoss preferred system design.....	11
5.7 Lifting and positioning.....	12
5.8 Mount the different equipment.....	12
5.9 Electrics.....	12
5.10 Instrumentation.....	12
5.11 Connections.....	12
5.12 Ensure free flow.....	13
5.13 Verify setting of safety/relief valves.....	13
5.14 Flush the pump.....	13
5.15 Bleed and remove air from the pump.....	13
5.16 Verify direction of rotation.....	13
5.17 Commissioning.....	13
5.18 Check the filter condition.....	13
5.19 Instruct operator and maintenance personnel.....	13
6. Operation of motor pump unit.....	14
6.1 General safety information.....	14
6.2 What to listen and look for.....	14

7.	Maintenance and service of the pump unit	15
7.1	General safety information	15
7.2	Service and inspection interval for the pump	15
7.3	Shut down of the system	15
7.4	Disassembling and assembling the pump unit	15
7.5	Assembling the pump unit	16
7.6	Procedure for mounting pump back onto electric motor	16
7.7	Getting the pump unit back into operation	16
7.8	Storage of the pump	16
8.	Troubleshooting and scrapping criteria	17
8.1	General safety information	17
8.2	Operational conditions which can cause pump failures	17
8.3	Mechanical failure	17
8.4	Electrical failure	17
8.5	Responsibility	17
8.6	Scrapping criteria	17
	Subject index	18

Validity

This manual is valid for APP pumps with the following code numbers/serial numbers:

APP 0.6	Code no.	180B3048
	Serial no.	02
APP 0.8	Code no.	180B3037
	Serial no.	02
APP 1.0	Code no.	180B3049
	Serial no.	02

EC Declaration of Conformity

Danfoss A/S
 Danfoss High Pressure Pumps
 Nordborgvej 81
 6430 Nordborg
 Denmark

EG-Konformitätserklärung gemäß EG-Richtlinie 2006/42/EG	EC Declaration of Conformity according to Directive 2006/42/EC	Déclaration de conformité CE conformément à la Directive 2006/42/CE
Hiermit erklären wir, dass die Maschine gemäß 2006/42/EG entwickelt ist.	We hereby declare that the machine is designed according to the directive 2006/42/EC.	Par la présente, nous déclarons que la machine est conçue conformément à la Directive 2006/42/CE.
Beschreibung der Maschine Hochdruck-Pumpe	Machine description High pressure pump	Description de la machine Pompe haute pression
Maschinentyp APP 0.6-1.0 / APP 1.5-3.5 / APP 5.1-10.2 / APP 11-13 / APP 16-22 / APP 21-38	Machine designation APP 0.6-1.0 / APP 1.5-3.5 / APP 5.1-10.2 / APP 11-13 / APP 16-22 / APP 21-38	Type de machine APP 0.6-1.0 / APP 1.5-3.5 / APP 5.1-10.2 / APP 11-13 / APP 16-22 / APP 21-38
Seriennummer N/A	Serial number N/A	Numéro de série N/A
Technisches Dossier, Kontaktperson Leiter Qualitätsabteilung	Technical dossier, Contact person Manager Quality Department	Personne de contact pour le dossier technique Manager département qualité
Angewandte harmonisierte Normen DS/EN ISO 12100: 2011	Used harmonised standards DS/EN ISO 12100: 2011	Normes harmonisées appliquées DS/EN ISO 12100: 2011

Hersteller-Unterschrift / Titel:

Manufacturers signature / Title:

Signature du fabricant / Titre:



2012 - 08 - 30
Datum

2012 - 08 - 30
Date

2012 - 08 - 30
Date

Welm Friedrichsen
Leiter F&E

Welm Friedrichsen
Director R&D

Welm Friedrichsen
Directeur R&D

1. Introduction

1.1 General

The APP pumps and pump units are manufactured by Danfoss A/S, and are sold and marketed by a net of authorized distributors world wide.

This manual contains the necessary instructions for the installation, operation and service of the pumps used in a Sea Water Reverse Osmosis (SWRO) or Brackish Water Reverse Osmosis (BWRO) system.

The APP pumps must not be used for other purposes than those recommended and specified without first consulting your local pump distributor.



Use of the pump in other applications not suitable for the pump unit can cause damages to the pump unit, with risk of personal injury.



All personnel being responsible for operation and maintenance of the pump unit must read and fully understand these instructions, especially the section "Safety" before:

-
- Installing the pump unit
- Connecting the motor pump unit to the water system
- Connecting the electric motor and instrumentation
- Commissioning the unit
- Servicing the motor pump unit, mechanic and electric parts
- Decommissioning the motor pump unit

The pump must always be installed and used in accordance with existing national/local sanitary, safety regulations and laws.

It is the responsibility of the safety officer or the chief operator to assure compliance with all local regulations that are not taken into account in this manual.



Changing the pumps' or motor pump units' operational limits and hardware:

- Changes to the delivered pump or motor pump system may only be done with a written approval from Danfoss RO Solutions.
- Operation outside the Danfoss specifications requires a written approval from Danfoss RO Solutions.
- If any changes are made without written approval the warranty will automatically become void.

Ensure that these instructions are always readily available to all personnel concerned.

1.2 Symbols



Indicates something to be noted by the reader



Indicates a situation which will or could result in damage to the pump and its function



Indicates a situation which will or could result in personal injury and/or damage to the pump



Electrical hazard - Indicates a high-voltage warning



Safety glasses required



Hearing protection required



Safety shoes required



Safety helmet required

1.3 Manufacturer and customer service address:

Danfoss A/S
 RO Solutions
 Nordborgvej 81, D25
 DK-6430 Nordborg
 Denmark

Telephone: +45 7488 4024
 Fax: +45 7445 3831
 Email: ro-solutions@danfoss.com
 Homepage: www.ro-solutions.com

Your local Danfoss pump distributor can be found on our homepage.

Data sheets and instructions on all accessories are available on www.ro-solutions.danfoss.com

CE Declaration of Conformity can be found on page 5.

2. Safety



2.1 General information

Dangers that can arise from not following the instructions:

When the pump or pump system is managed by untrained personal, there is a danger of:

- Death or fatal injuries
- Costly damages and claims



Electrical hazard

All electrical installation work must only be carried out by authorized personnel in accordance with EN60204-1 and/or local regulations.

Install a lockable circuit breaker to avoid inadvertent starting.

Protect the motor and other electrical equipment from overloads with suitable equipment.



Protective garments must be worn

It is recommended to place a local safety switch near by the pump, enabling service personal to cut power for the electric motor. This prevents unintentionally starting the unit during servicing.



Always wear suitable safety clothing when handling the pump.

When working near the pump system, safety proof boot/shoes, safety glasses, ear protection and safety helmet must always be worn.



Danger Hot Do not touch

Under certain operational conditions the surface of the pump can be above 60°C / 140°F. Under these conditions the pump must be labelled with a "Danger Hot" sign.

When using an electric motor, the motor must always be supplied with adequate cooling ventilation.

When using an electric motor together with a VFD, the motor must be designed for operation with VFD. VFD operation may increase the temperature inside the electric motor if the motor is not designed for VFD operation.



Before start-up, the settings for all protective devices, for example, sensors/switches and safety valves must be verified and free flow from safety valves must be ensured.



All pipe and hose connections must be stress-free mounted, securely fastened to the pumps and well supported. Improper installation will or could result in personal injury and/or damage to the pump.

Use of this manual does not relieve operation and maintenance personnel of the responsibility of applying normal good judgment in the operation and care of the pump and its components.

2.2 Preferred system design

Danfoss recommends building systems with a high degree of safety. See Danfoss preferred system design and PI&D in Data sheet and Instruction which are found in appendix 1 (Data sheet) and 2 (APP pump instruction).



It is always the system builders responsibility that the system design does not cause any kind of hazard and is adapted to local regulations and standards.

Proper installation, care of start up and shut-down devices and over-pressure protection equipment is essential.

2.3 Commissioning and servicing the unit

It is recommended that commissioning and servicing are carried out by a minimum of two people, where one is acting as a supervisor.

2.4 Adhere to the following important points

- Before using the pump/pump unit it is very important to read and understand this user manual.
- Do not try to lift the pump unit manually; most of the pumps weight more than 20 kilos, see specific weight for the pump in the Data sheet, which is found in appendix 1.
- Do not run the pump if it is completely dry and not bled.
- Do not mount the pump without the bell housing and a flexible coupling.
- Do not try to start the unit before the system components are mounted, bled and adjusted.

2.5 In case of doubt

Please contact Danfoss A/S in case of doubt. Contact information are listed in section 1.3, Manufacturer and customer service address.

3. Technical data



3.1 Approved applications and operational limits for the pumps

The pump and the pump units are designed for the use in a Sea Water Reverse Osmosis (SWRO) or Brackish Water Reverse Osmosis (BWRO) systems.

The APP pumps must not be used for other purposes than those recommended and specified without first consulting your local pump distributor.



Use of the pump in other applications not suitable for the pump unit can cause damages to the pump unit, with risk of personal injury.

For system integration of the pumps, please see Data sheet and Instruction which are found in appendix 1 (Data sheet) and 2 (APP pump instruction).

3.2 Application range

See Data sheet in appendix 1.

3.3 Electric motor data

See recommended motor in Data sheet, appendix 1 or IOM for motors, appendix 3. The motors mentioned are the most common used motors by Danfoss High Pressure Pumps.

3.4 Noise and vibration

Noise level for a motor pump unit with a "standard" motor measured according to EN ISO 3744:2010, see Data sheet in appendix 1. Possibilities to reduce noise and vibration are described in the same Data sheet.

3.5 General arrangement

Dimensions for the different pumps, see Data sheet in appendix 1.

3.6 Space requirement

For service and replacement of the complete motor pump unit, it is recommended having sufficient space around the unit.

For easy access to the unit, at least 1 meter/ 40 inches available space should be kept free around the pump. When working with high pressures, space demands should reflect the required safety requirements.



3.7 Filtration

(10µm absolute [β10 =5000])

Requirements are specified in Data sheet, appendix 1 and APP pump instruction, appendix 2.

Danfoss recommends not to build a filter bypass function or use filters with an integrated bypass. If the above recommendation is not followed the warranty for the pump will automatically become void.

It should be possible to monitor the condition of the filter via the differential/delta pressure across the filter.

Using insufficient filtration or a filter bypass can cause a failure or decreased service life of the pumps.

3.8 Properties of water

It is recommended NOT to use the pumps in feed water concentrations higher than 50,000 ppm TDS without consulting your local Danfoss pump distributor.



3.9 Air bubbles

Large bubbles in a pressurised RO system can result in damage to piping, equipment and the pumps.

All air must be bled from both the low-pressure and high-pressure side before the RO system is pressurised. Special consideration should also be given to air bubbles in feed flow and continuously feed into the pumps as it else can give cavitation.



3.10 Chemicals

The pumps should not be exposed to any chemicals that can result in damage to piping, equipment and internal parts of the pumps.

4. Arrival inspection, transportation, handling, lifting and storage

4.1 Arrival inspection

The pump is packed in a cardboard or wood box with plugs in the port connections to protect the pumps from damage during transportation.

Immediately check the shipment for damage on arrival and make sure that the name plate/type designation is in accordance with the packing slip and your order.

Remove all packing materials immediately after delivery. In case of damage and/or missing parts, a report should be drawn up and presented to the carrier at once.



4.2 Warning

Before any lifting operation is performed, environmental conditions must be taken into consideration (Ex-rated areas, wind speed, wet/dry conditions, lifting height, etc.).

4.3 General safety information

Personnel involved in lifting and transporting the equipment (see Safety, chapter 2) must be trained in handling and safety procedures when lifting heavy loads. Many of the pumps and pump units weigh more than 20 kilos, which requires lifting slings and suitable lifting devices; e.g. an overhead crane or industrial truck to be used as minimum.

4.4 Transport and handling

Small pumps which have a weight below 20 kilos (weight can be found in the Data sheet in appendix 1) can be handled by hand if they are not mounted together with an electric motor. The weight of a small pump with a motor will be above 20 kilos.

Pumps which have a weight above 20 kilos (see Data sheet, appendix 1) must be handled by using lifting eyes and slings.

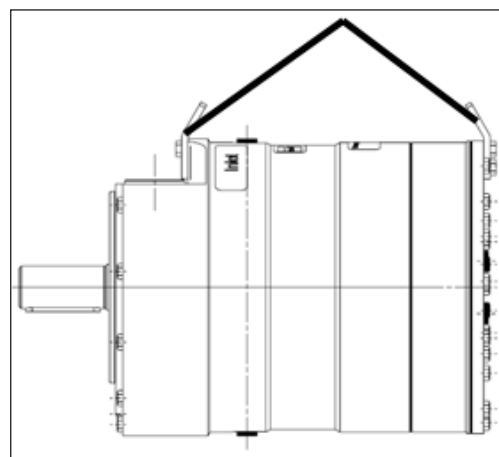
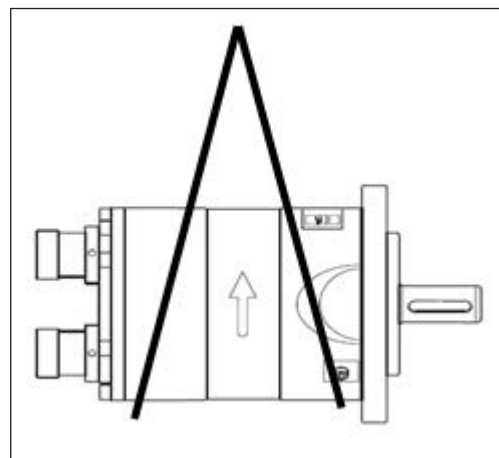

Never use only one sling and make sure the slings does not slip off the pump.

When the pump is mounted together with an electric motor, the pump unit always weight more than 20 kilos and must be handled by using slings around the pump unit.

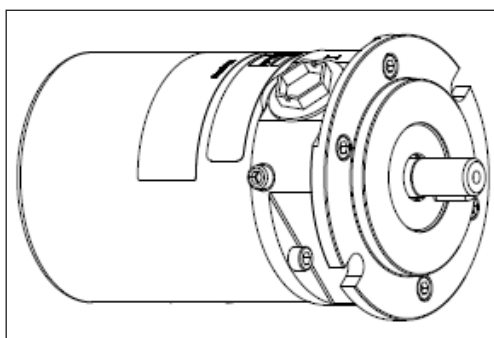
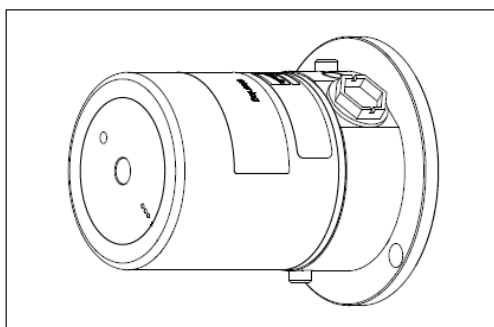

See below examples of where to/not to attach the lifting slings on the pump unit:

Correct lifting with 2 separate slings:

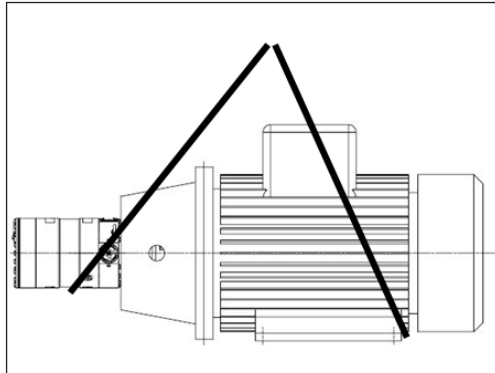

Incorrect lifting can result in personally injury and/or damage to the pump unit.

4.5 Return to supplier

Please see maintenance chapter 7.

4.6 Storage

Each pump is tested before shipment and therefore holds water, so for storage temperature and frost protection see Data sheet in appendix 1 or APP pump instruction in appendix 2.

The pumps are NOT delivered frost protected from the factory.

Wrong lifting:

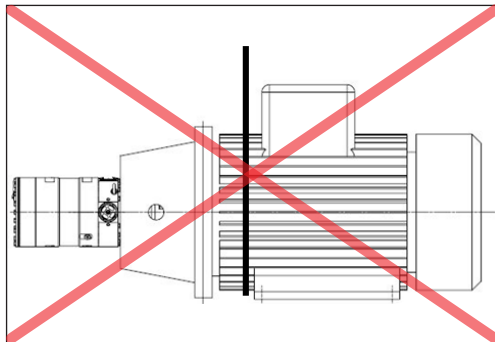
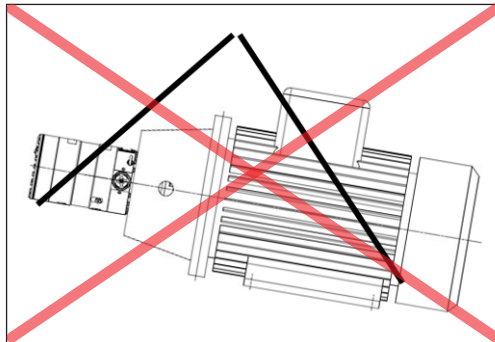

When lifting the pump unit, one sling must be attached to the electric motor and one sling around the pump.

Only some motors and pumps have specific lifting eyes.

**Do not use connections/nozzles for lifting!
Do not use only one sling!**

Make sure that the unit/load is balanced before attempting to lift, as the centre of the mass is different from pump to pump and pump unit to pump unit.

How to mount the pump and the electric motor correctly together, see Data sheet in appendix 1 or APP pump instruction in appendix 2.

5. Installation and commissioning



5.1 Important dimensions

Physical dimensions and connections for the pump unit are described in Data sheet, appendix 1.



5.2 Cleanliness

It is very important that the tubes and pipes are **completely clean**: no dirt, chips or burrs are allowed. Flush all piping before connecting the high pressure pump to ensure the system is clean. Internal surfaces of the piping must not be corroded. If dirt or rust is not removed, the pump and the valves can be damaged and in the worst case damaged beyond repair!



5.3 Fluid temperature

Before start-up, the fluid and pump housing temperature must be above the minimum start-up temperature, see Data sheet, appendix 1.

5.4 Electrical data

Check voltage, current frequency and rated power on the electric motor and VFD setting name plate on both the motor and the VFD.



5.5 Local regulations

Commissioning must always be done in accordance with valid regulations and local standards.

5.6 Pre mounting checklist, based on Danfoss preferred system design

Schematic 1: Recommended system design

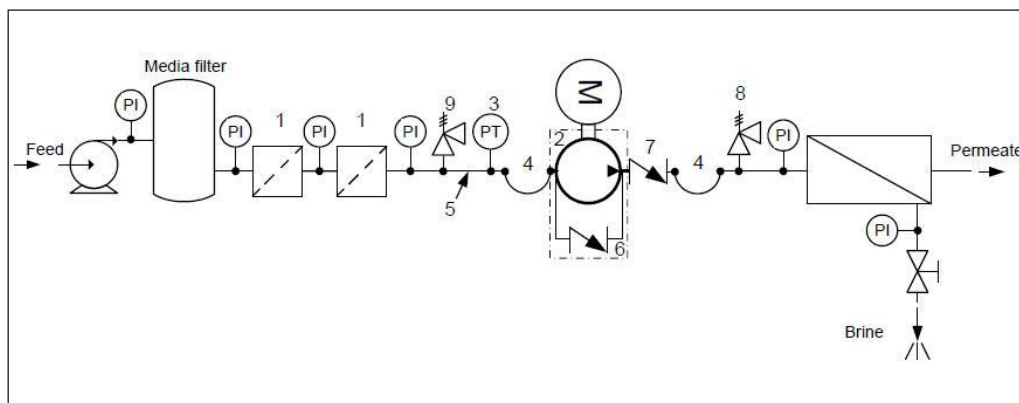

Table 1: Check points when assembling and commissioning system

	Check points	Comment	OK ?
CP1	Ensure that the environmental conditions are safe.	See Arrival inspection, transportation, handling, lifting and storage, chapter 4.	
CP2	Minimum and maximum start-up temperature for fluid and pump.	See Data sheet or Instruction, appendices 1 and 2.	
CP3	Filtration condition (10µm absolute (β10 = 5000))	See Danfoss requirements in Data sheet and Instruction, appendices 1 and 2	
CP4	Power supply for electric motor and VFD.	See Data sheet for the used motor and VFD, appendix 1.	
CP5	Safety circuit / breaker must be sized for the motor and environment (corrosion and humidity)	See Data sheet for the used safety circuit.	
CP6	Bolts and screws must conform to environmental conditions as well as fluid and torque requirements.		
CP7	Instrumentation, pressure switch should be designed to conform to the environment (corrosion and humidity).	See Data sheet for the used equipment.	
CP8	Check the factory settings of the safety/relief valves or pressure relief valves (8 & 9).	See Data sheets for the used valves.	
CP9	Check the settings of the pressure transmitter/switch (3) set at min. inlet pressure.	See Data sheet or Instruction, appendices 1 and 2.	
CP10	Check that all pressure indicators (PI) are selected to be able to measure the system pressure range.	Scaling should at least be 1 Bar or more precise.	
CP11	Check coupling distance (air gab – movement of the spider)	3 – 5 mm	
CP12	Check correct connections on the pump (in & outlet)		
CP13	Check piping for possible air gaps.		



5.7 Lifting and positioning

Lift the pump unit onto base (Remember vibration dampers, if needed). Fasten the motor to the base.

See also chapter 4, Arrival inspection, transportation, handling, lifting and storage.

5.8 Mount the different equipment

(connections, pipes, tubes, check and safety/relief valves, etc.)

- The hard piping and flexible hoses used must be of proper design and must be installed in accordance with the manufacturer’s recommendations. (see also Data sheet for Hose and hose fittings and Instruction for Assembling Hose kit - both available on www.ro-solutions.danfoss.com).
- Misalignment of the hard pipes may place stress on the pump port connection and may damage the pump.
- Prevent excessive external pipe load.
- Do not connect piping by applying external force (use of wrenches, crane, etc.) Piping must be aligned without residual stress.
- Do not mount expansion joints so that their force applies internal pressure on the pump connections.

5.9 Electrics

All electrical installation work must be carried out by authorized personnel in accordance with EN60204-1 and/or local regulations. (see also Safety, chapter 2)

Mount the safety circuit breaker, turn the circuit off and lock it in the off position.

Mount the power cable on the electric motor.

If a VFD is used, adjust the protective motor switch/VFD to the current limits found on name plate of the electric motor.

5.10 Instrumentation

The pressure switch/sensor should be mounted as close to the pump as possible. It is recommended to test the pressure/sensor switch via an instrumentation manifold.

Mount the pressure switch/sensors according to the manufacturer’s instructions.

5.11 Connections

Mount connections and maybe check valve(s). Mount and tighten as specified.

5.12 Ensure free flow

Ensure that the flow from safety/relief valves 8 and 9 is completely unhindered. A blocked safety/relief valve can cause excessive build-up of pressure and thereby cause dangerous situations and damage to the whole system.

5.13 Verify setting of safety/relief valves

Make sure, the safety/relief valves 8 and 9 are placed correctly.

Check the pressure settings on the name plates of the safety/relief valves. If they are OK, continue. Otherwise replace the safety/relief valves.

5.14 Flush the pump

Fully open the pressure valve at the brine site.

Close all the bleeding and draining plugs on the high pressure pump.

Start the feed pump and ensure that the flow from the feed pump to the high pressure pump is unhindered.

5.15 Bleed and remove air from the pump

Open bleeding plugs. Keep the plugs open until only water leaves the high pressure pump.

5.16 Verify direction of rotation

An arrow can be found on the pump or pump unit. The direction of rotation must always follow the arrow.

Unlock the safety circuit breaker. Start the motor for 1 second and observe the direction of rotation either looking on the fan of the motor or on the coupling true the hole in the bell housing (not available on all bell houses). If the motor is turning the wrong direction, switch two phases in the connection box of the motor or reprogram the direction in VFD.

5.17 Commissioning

- Close all the bleeding and draining plugs.
- Open the pressure valve at the brine site.
- Switch the safety circuit breaker on for both motor(s) and VFD(s).
- Start the feed pump.
- Start the high pressure pump.
- If a VFD or a soft starter is used a ramp up time of minimum 10 second is required to avoid damage of internal pump parts.
- Monitor the inlet pressure and outlet pressure of the high pressure pump and look for leakages.
- Check the pressure indicator function by slowly closing the valves. The pump unit should stop when the minimum inlet pressure and maximum outlet pressure has been reached.

- Adjust the pressures to the specified inlet and outlet pressure for the system and let the pump unit run until the electric motor and pump temperature is stable.
- If the system is running within the system design limits, the system is released for operation.



5.18 Check the filter condition

Evaluate dirt found in filter, replace filter elements, if necessary.



5.19 Instruct operator and maintenance personnel

Before using the pump/pump unit, the personnel must be instructed in using the pump/pump unit, its function, components, documentation and safety.

Danfoss offers commissioning and service at system manufacturer's location. Rate quotes are offered upon request.

6. Operation of motor pump unit



6.1 General safety information

Before inspecting the pump unit, read the Safety chapter 2 in this user manual.

Danfoss recommends at the same time also to check the filter and membrane condition and evaluate dirt found, replace filter and membrane elements if necessary.

6.2 What to listen and look for

If the following is observed, please act as indicated:

- A) Re-check all bolts and, if necessary, contact the maintenance department in order to have all bolts tighten to the specified levels.
- B) Leakage – if a small leak dripping from the bell housing is observed, contact the maintenance department.
- C) Leakage – if there is a large leak, the unit should be stopped as soon as possible. Contact the maintenance department.
- D) High frequency tones – safety/relief valves are either damaged or running very close to their cracking pressure, stop the unit immediately. Contact the maintenance department.
- E) Non-standard noise or vibration from the pump requires the unit to be stopped immediately. Contact the maintenance department.
- F) Very high temperatures – can indicate one or more damaged parts inside the pump. The pump then needs to be stopped immediately and inspected before running again. Contact the maintenance department.
- G) Drop in flow and/or pressure - can indicate wear on one or more parts inside the pump. The pump needs to be stopped immediately and inspected before running again. Contact the maintenance department.
- H) Other observations or troubles, please see appendix 7, Right and Wrong or the Trouble shooting guide, appendix 6. Both appendices give good advises on design, installation, wiring and trouble-shooting.

If the pump is not stopped for inspection, it can lead to damage of the pump. See also service and warranty section in the Data sheet, appendix 1; APP pump instruction or Instruction for recommended service intervals in appendix 2 and 4.

Danfoss offers service of the pump at the system manufacturer's location as well as training in servicing the pump. Quotes are offered upon request.

7. Maintenance and service of the pump unit



7.1 General safety information

Before servicing the pump unit, it is necessary to read and understand this user manual, especially the Safety, chapter 2. Remember to wear suitable safety equipment according to Safety, chapter 2.

7.2 Service and inspection interval for the pump

Maintenance and service intervals are depending on the cleanness level of the water, hydraulic load and temperature of the pump unit. The most important parameter is the cleanness of the water.

See the section Service and warranty in the Data sheet, appendix 1, APP pump instruction and Instruction for recommended service intervals in appendix 2 and 4.

For spare parts and service tools, please see Parts list, appendix 5.

Danfoss offers service of the pump at the system manufacturer's location and training in servicing the pump. Quotes are offered upon request.

7.3 Shut down of the system

- A) Open the pressure valves at the brine site to release the pressure.
- B) Stop the high pressure pump.
- C) Stop the feed pump.
- D) Turn on the motor safety circuit breaker for both the high pressure pump, the feed pump and the VDF if used and lock them. Only the employees servicing the pump unit should be able to unlock/activate the switch again.
- E) Open bleeding and drain plugs. Wait until the pump and system are emptied for water.



- F) Slowly unscrew and remove the bolts and gaskets from the in/out hoses or pipes, be careful about jets of water. Be aware that there still can be pressure in the system, which will be released when unscrewing and removing the bolts and gaskets.
- G) Attach the lifting equipment to the pump unit. For instructions on lifting the complete pump unit, see chapter 4, Arrival inspection, transportation, handling, lifting and storage.
- H) For the small pumps unscrew the bolts holding the pump to the bell housing and for the bigger pumps, unscrew the bolts holding the pump and bell housing to the

motor and afterwards unscrew the bolts/nuts holding the pump and bell housing together.

- I) Carefully pull the pump out of the bell housing by using lifting equipment, if necessary.
- J) Hold the pump in different positions above a drip tray; this should allow most of the left-over water trapped in the pump to plug out. Clean and dry the pump surface and plug the bleeding and draining plugs.
- K) Move the pump to a clean and safe location where the pump can be inspected/serviced.

7.4 Disassembling and assembling the pump unit

- A) Remove all connections from the pump.
- B) Disassemble the pump according to the Disassembling and Assembling Instruction (available at www.ro-solutions.danfoss.com At the website you can also find the Changing pistons instructions for APP 11-13 and APP 16-22 as well as for APP 21-38). Clean all the parts and surfaces with a fluid compatible with the materials found in the pump. Wipe the parts clean and dry with a dry and lint-free cloth.
- C) Inspect all parts including shaft seal and if necessary, replace them; see Parts list, appendix 5 and APP pump instruction, appendix 2 or general instruction for Recommended service intervals, appendix 4.
- D) If the pump is going to be returned to Danfoss for repair or a warranty claim, it is important that Danfoss, besides your contact information and reason for returning, gets the below information before shipping.

Product information (see label on product)		
Only 1 product on each report.		
Product type:	Code number	Serial number
Operational conditions		
Application:	Inlet pressure:	Rpm:(pump/motor only):
Hours of operation:	Outlet pressure:	Number of duty cycles (valves only):
Filtration (µ, absolute/nominal) :	Flow:	Water temperature:
Water type:	TDS:	Pumps in parallel (yes/no):

After Danfoss has been informed about the return, you will receive a return number and a template to fill out. One copy should be attached to the shipment and one copy should be sent to the E-mail address on the template.

Returns without a return number will be rejected !!!

7.5 Assembling the pump unit

Assemble the pump according to the Disassembling and Assembling Instruction (available at www.ro-solutions.danfoss.com).

7.6 Procedure for mounting pump back onto electric motor

Do always follow the procedure delivered with the instructions from the coupling manufacturer!



Mount the flexible coupling and bell housing according to the Data sheet, appendix 1 and APP pump instruction, appendix 2.

7.7 Getting the pump unit back into operation

Find instructions of how to put the pump unit back into operation in chapter 4, Arrival inspection, transportation, handling, lifting and storage and Installation and commissioning, chapter 5.

7.8 Storage of the pump

If the pump has to be shut down for a longer period or put on the shelf, instructions can be found in Storage-chapter in Data Sheet, appendix 1 or APP pump instruction, appendix 2.

8. Troubleshooting and scrapping criteria



8.1 General safety information

Before inspecting the pump unit, it is necessary to read and understand this user manual, especially the Safety chapter 2.

Remember to wear suitable safety equipment according to Safety chapter 2.

8.2 Operational conditions which can cause pump failures

The following conditions can cause a pump failure :

- The pump is running dry.
- The inlet pressure is too high.
- The inlet pressure is too low.
- The viscosity of the fluid is too high.
- The temperature of the fluid being pumped is too high.
- The ambient temperature is too high.
- The pump is running against a blocked port/closed manual valve.
- The pump is operating at a pressure above the operational specification.
- The pump is running with a non-specified/ approved fluid.
- The pump is running in the wrong direction.
- The filtration is insufficient.
- The pump is not being serviced according to Danfoss specifications (end of life).
- There is excessive mechanical load on the shaft coupling and piping.

If a VFD is used and wrongly programmed, it can damage the pump and lead to high temperatures or other dangers.

Therefore all electrical installation work must only be carried out by authorized personnel in accordance with EN60204-1 and/or local regulations.

8.5 Responsibility

Danfoss takes no responsibility for any other abnormal injuries, risks or damages that could arise caused by abnormal conditions, vibrations, corrosion, abrasives, foreign objects or excessive temperatures and shall not be liable for any consequential or incidental damages.

8.6 Scrapping criteria

Whether the pump can be repaired or need to be scrapped depends on how damaged the internal parts are or how damaged the whole unit is. Please use appendix 6, Trouble shooting guide as guideline or send the pump to Danfoss head-quarter in Denmark for evaluation.

For other observations or troubles, please see appendix 7, Right and Wrong which gives good advises in design, installation, wiring and troubleshooting.



Danger Hot
Do not touch

8.3 Mechanical failure

If the pump is running dry, the temperature will quickly increase which can be dangerous, depending on how long time the pump is running dry.

If there is any leaking at start up or leaking arises during operation, the high pressure can lead to eye or skin damage.

Leaking can result in flooding, which again can cause a risk of slipping, tripping or falling.

If water is dripping into the electric motor; it can lead to electric shock, fire, short of circuit or even death. In order to avoid water dripping into the electric motor, see Installation and commissioning, chapter 5 and Operation, chapter 6.



Electrical hazard

8.4 Electrical failure

If the wiring/connection of the electric motor is not correct or the earth connection is missing, it can lead to electric shock, burn damages, fire or even death.

Subject index

A		G		S	
Address	6, 7, 15	General information	7	Safety	6, 7, 8, 9, 12, 13, 14, 15, 17
Air bubbles	8	Guideline	17	Safety valve	7
Appendix	7, 8, 9, 10, 11, 12, 14, 15, 16, 17	H		Scrapping criteria	17
Application range	8	H		Serial number	4
Approval	6	Handling	7, 9, 12, 15, 16	Servicing	6, 7, 14, 15
Arrival	9, 12, 15, 16	I		Shut down	15, 16
Assembling	12, 15, 16	Inspection	9, 12, 14, 15, 16	Space requirement	8
B		Installation	6, 7, 11, 12, 14, 16, 17	Spare part	15
Bleed	7, 8, 13, 15	Instruction	6, 7, 8, 10, 12, 14, 15, 16	Start up	7, 17
C		Instrumentation	6, 12	Storage	9, 10, 12, 15, 16
Checklist	11	Introduction	6	Symbols	6
Check points	12	M		System	6, 7, 8, 11, 12, 13, 14, 15
Chemicals	8	Maintenance	6, 7, 10, 13, 14, 15	Systems	7, 8
Cleanliness	11	Mechanical failure	17	T	
Commissioning	6, 7, 11, 12, 13, 16, 17	Mounting	16	Table of content	2
Connections	7, 9, 10, 11, 12, 15	N		Technical data	8
Coupling	7, 12, 13, 16, 17	Name plate	9, 11, 12, 13	Temperature	7, 10, 11, 12, 13, 14, 15, 17
D		Noise	14	Transportation	6, 9, 12, 15, 16
Danger	7, 13, 17	L		Trouble shooting	14, 17
Data sheet	7, 8, 9, 10, 11, 12, 14, 15, 16	Leaking	17	V	
Declaration of Conformity	5, 6	Lifting	6, 9, 10, 12, 15, 16	Valve	7, 11, 12, 13, 14, 15, 17
Design	7, 8, 9, 11, 12, 14, 17	Local regulations	6, 7, 11, 12, 17	W	
Distributor	6, 8	O		Warning	6, 9
Dimensions	8, 11	Operation	6, 7, 8, 9, 13, 14, 16, 17		
Disassembling	15, 16	Operational conditions	7, 17		
E		P			
Electric motor	6, 7, 8, 9, 10, 11, 12, 13, 16, 17	Piping	8, 11, 12, 17		
Electrical failure	17	Positioning	12		
Electrical hazard	6	Preferred system design	7, 11		
Electrics	12	Pre mounting	11		
EU Declaration of Conformity	5	Protection	6, 7, 10		
F		R			
Failure	8, 17	Relief valve	12, 13, 14		
Filter condition	13	Responsibility	6, 7, 17		
Filtration	8, 12, 17	Return	10, 15		
Flow	7, 8, 13, 14	Rotation	13		
Fluid	11, 12, 15, 17				
Flush	11, 13				

Danfoss A/S
 High Pressure Pumps
 DK-6430 Nordborg
 Denmark

Danfoss can accept no responsibility for possible errors in catalogues, brochures and other printed material. Danfoss reserves the right to alter its products without notice. This also applies to products already on order provided that such alterations can be made without subsequent changes being necessary in specifications already agreed. All trademarks in this material are property of the respective companies. Danfoss and the Danfoss logotype are trademarks of Danfoss A/S. All rights reserved.



User manual

Appendices for Installation, Operation and Maintenance Manual APP pumps (APP 0.6-1.0)



APP 0.6-1.0

Table of Contents

1.	Data sheet for APP 0.6-1.0 pumps (521B1136).....	3
2.	APP pump instruction APP 0.6-3.5 (180R9065)	13
3.	IOM Electric motors (180R9230).....	21
4.	Recommended service intervals for APP pumps (180R9199)	25
5.	APP Parts list (521B0941).....	29
6.	Trouble shooting guide	35
7.	Right and wrong (180R9042)	45



Data sheet

Data sheet APP 0.6-1.0



Data sheet for APP 0.6-1.0 pumps (521B1136)

Table of Contents

1.	General information
2.	Benefits
3.	Technical data
4.	Flow at different rpm
5.	Flushing valve
6.	Power requirements
7.	Temperature and corrosion
7.1	Operation
7.2	Storage
8.	Noise level
9.	Filtration
10.	Dimensions
10.1	Pump
10.2	Complete unit
11.	Installation
11.1	Mounting
11.2	Open-ended system with direct water supply
11.3	RO system with APP pump
12.	Service
12.1	Warranty
12.2	Maintenance
12.3	Repair

1. General information

APP 0.6, APP 0.8 and APP1.0 pumps are designed to supply low viscosity and corrosive fluids under high pressure, eg in seawater reverse osmosis filtration applications and for high-pressure salt water pumping.

The pumps are based on the axial piston principle enabling a very light and compact design. The design ensures that lubrication of the moving parts in the pumps is provided by the fluid itself. No oil lubrication is thus required.

All parts included in the pumps are designed to provide long service life, ie long service life with

a constantly high efficiency and minimum of service required.

The pumps are fixed displacement pumps in which the flow is proportional to the number of revolutions of the input shaft and the pump displacement, regardless of any counter-pressure.

The pumps are supplied with an integrated flushing valve that allows the salt water to flow from inlet to the outlet, when the pump is not running.

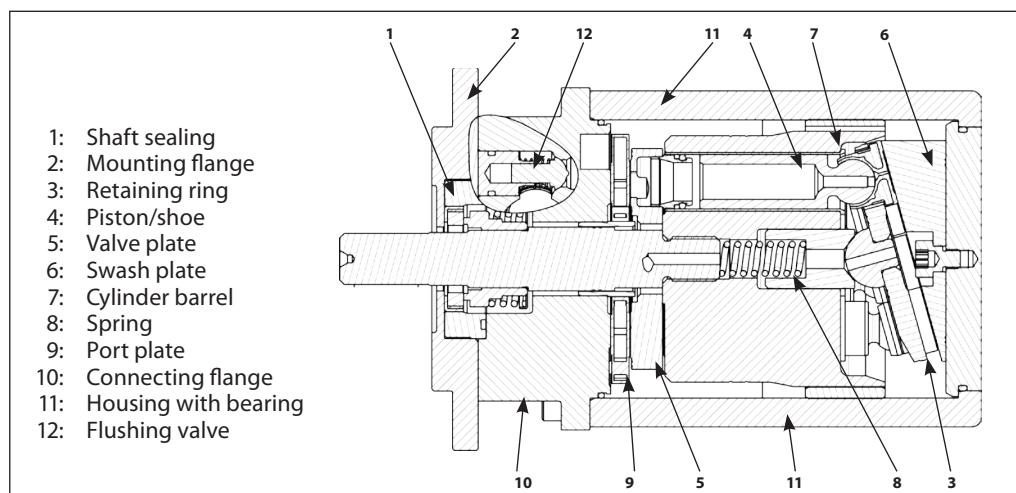

2. Benefits

- One of the smallest and lightest pumps on the market.
- Can be powered by a combustion engine.
- Long service life / No preventive maintenance required in the warranty period.
- Generates insignificant pulsations in the high-pressure line.
- No oil lubricant required.
- Integrated flushing valve
- All parts of the pump are made of high corrosion resistant materials e.g. Duplex (EN1.4462/UNS S31803-S32205) and Super Duplex (EN1.4410/UNS S32750) stainless steel and carbon reinforced PEEK
- High efficiency

3. Technical data

APP pumps		APP 0.6	APP 0.8	APP 1.0
Code number		180B3048	180B3037	180B3049
Geometric displacement	cm ³ /rpm	4	5.07	6.3
	in ³ /rpm	0.24	0.31	0.38
Rated flow (3000 rpm) ¹⁾	m ³ /h	0.6	0.8	1.0
	gpm	2.6	3.5	4.4
Outlet min. pressure ²⁾	bar	20	20	20
	psi	290	290	290
Outlet max. pressure, continuous. ³⁾	bar	80	80	80
	psi	1160	1160	1160
Outlet max. pressure, intermittent ⁴⁾	bar	100	100	100
	psi	1450	1450	1450
Inlet min. pressure	bar	0.5	0.5	0.5
	psi	7.3	7.3	7.3
Inlet max. pressure, continuous	bar	5	5	5
	psi	72.5	72.5	72.5
Inlet max. pressure, peak	bar	10	10	10
	psi	145	145	145
Max. speed continuous ⁵⁾	rpm	3450	3450	3450
Min. speed continuous	rpm	700	700	700
Power requirement at 80 bar and 3000 rpm	kW	1.9	2.4	2.9
	hp	2.5	3.3	3.9
Torque at 80 bar	Nm	6.1	7.6	9.3
	lbf-ft	4.5	5.6	6.85
Weight	Kg	5.2	5.2	5.2
	lb	9.7	9.7	9.7
Integrated flushing valve		YES	YES	YES

- 1) Typical average flow at 80 bar (1160 psi).
- 2) For lower pressure, please contact Danfoss RO Sales Organization.
- 3) For higher pressure, please contact Danfoss RO Sales Organization.
- 4) Intermittent pressure is acceptable for less than 10 seconds per minute.
- 5) For speeds above 3000 rpm the pump must be boosted at a pressure of 1-5 bar (14.5 - 72.5 psi).

4. Flow at different rpm

Using the diagram shown below, it is easy to select the pump which fits the application best if the flow required and the rotation speed (rpm) of the pump are known.

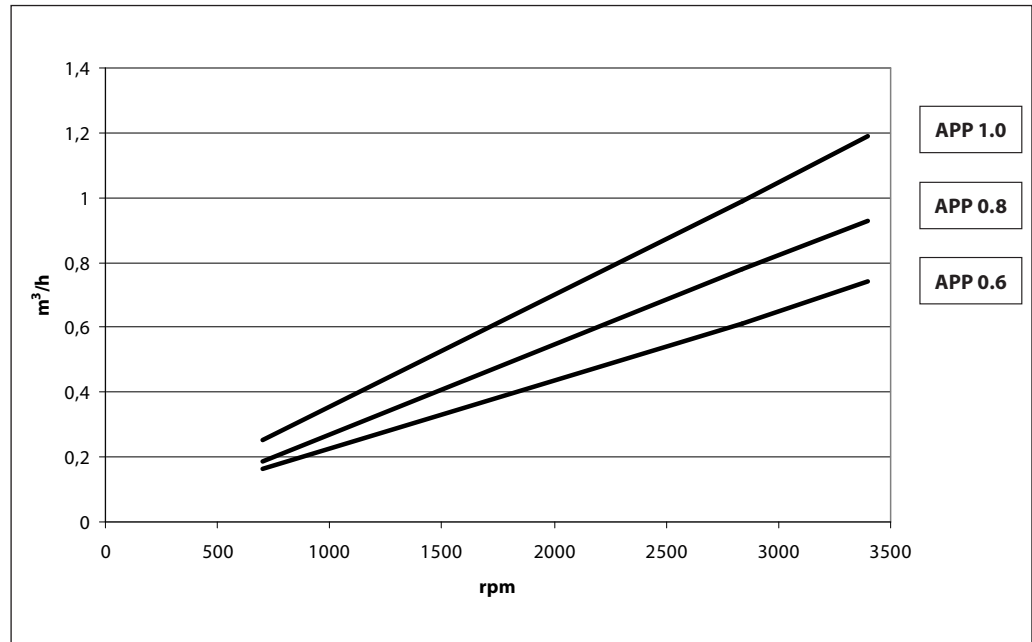

Furthermore, this diagram shows that the flow can be changed by changing the rotation speed of the pump. The flow/rpm ratio is constant, and the "required" flow can be obtained by changing the rotation speed to a corresponding value. Thus, the required rpm can be determined as:

$$\text{Required rpm} = \frac{\text{Required flow} \times \text{Rated rpm}}{\text{Rated flow}}$$

5. Flushing valve

The diagram shows pressure difference across flushing valve:

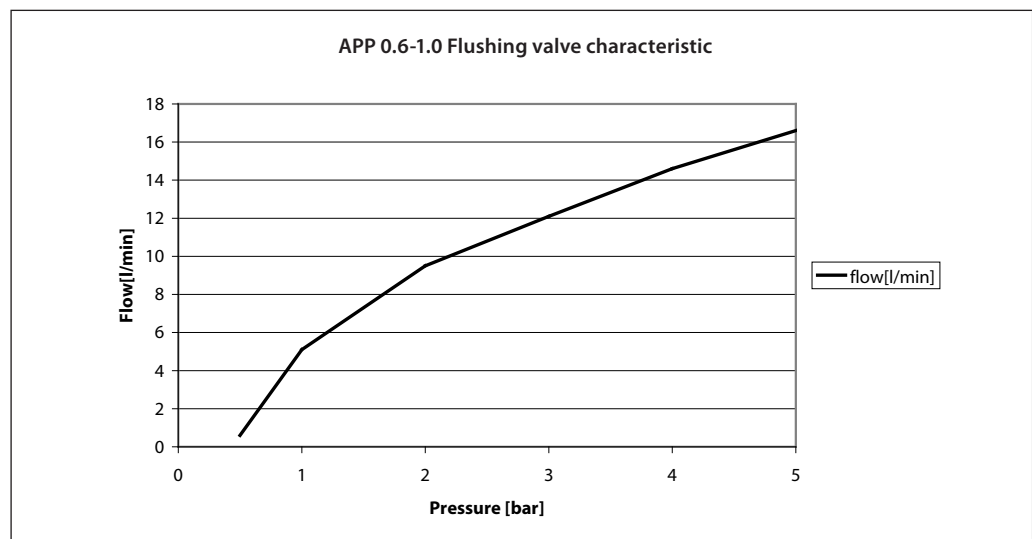

6. Power requirements

Pump model	Flow			Pressure			rpm	Calc. factor
				60 bar	70 bar	80 bar		
	l/min	m ³ /h	gpm	870 psi	1015 psi	1160 psi		
APP 0.6	10.2	0.61	2.69	1.38 kW	1.61 kW	1.84 kW	2840	475.8
APP 0.6	12.3	0.74	3.25	1.66 kW	1.94 kW	2.21 kW	3400	475.8
APP 0.8	13.6	0.82	3.61	1.73 kW	2.02 kW	2.31 kW	2840	475
APP 0.8	16.3	0.98	4.31	2.07 kW	2.41 kW	2.76 kW	3400	475
APP 1.0	16.5	0.99	4.37	2.14 kW	2.49 kW	2.85 kW	2840	474.6
APP 1.0	19.8	1.19	5.24	2.57 kW	2.99 kW	3.42 kW	3400	474.6

The power requirements can be determined using one of the following guiding equations:

$$\text{Required power} = \frac{\text{l/min} \times \text{bar}}{\text{Calc. factor}} \text{ [kW]} \text{ or } \frac{16.7 \times \text{m}^3/\text{h} \times \text{bar}}{\text{Calc. factor}} \text{ [kW]} \text{ or } \frac{0.26 \times \text{gpm} \times \text{psi}}{\text{Calc. factor}} \text{ [kW]}$$

- 1 hp = 0.75 kW
- 1 kW = 1.34 hp
- 1 gpm = 3.79 l/min
- 1 l/min = 0.26 gpm
- 1 m³/h = 4.40 gpm
- 1 gpm = 0.23 m³/h

7. Temperature and corrosion

7.1 Operation

Fluid temperature: +2° C to +50° C (+35.6° F to 122° F) - dependent on the NaCl concentration
Ambient temperature: +2° C to +50° C (+35.6° F to 122° F)

The chart below illustrates the corrosive resistance of different types of stainless steel related to NaCl concentration and temperature. All critical parts of the APP water pump is made of Super Duplex.

If the water pump is operated at high salinity, always flush the water pump with fresh water at operation stop in order to minimize the risk of crevice corrosion.

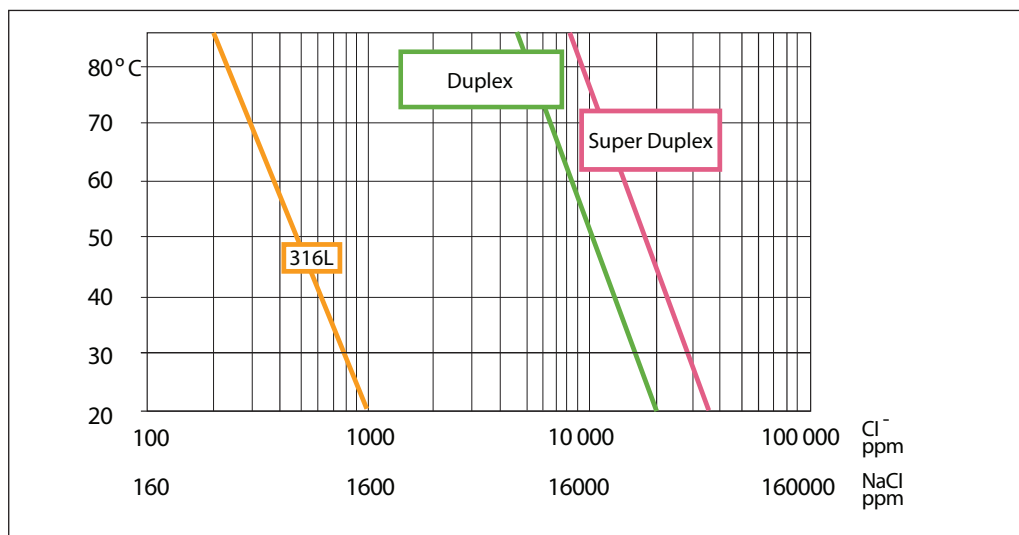

7.2 Storage

Storage temperature:
 -40°C to +70°C (+40°F to 158°F) – provided that the pump is drained of fluid and stored “plugged”

Frost protection is required at temperatures below 2°C. Danfoss recommends to use DOWFROST from DOW Chemical Company or Chilsafe mono propylene glycol from Arco Chemical Company.

8. Noise level

The table indicates the **approximate** noise level in dB(A) measured at a distance of 1 m from the

pump in a reverberation room:

Type	60 bar (870 psi)	60 bar (870 psi)
	1500 rpm	3000 rpm
APP 0.6	70	73
APP 0.8	73	75
APP 1.0	73	75

Generally, noise will be reduced if speed is reduced and vice versa. Use flexible hoses in order to minimize vibrations and noise.

Since the pump is typically mounted on a bell housing or frame, the noise level must be determined for the complete unit (system).

It is therefore very important that the motor/pump unit is mounted correctly on a frame with antivibration isolation to minimize

vibrations and noise.

The noise level is influenced by:

- The speed of the pump, high rpm create more noise than low rpm
- Rigid mounting of the pump generates more noise than flexible mounting
- Pipe mounting direct to the pump increases the noise level compared to a flexible hose

9. Filtration

As water has very low viscosity, the APP pumps have been designed with very narrow clearance in order to control internal leakage rates and improve component performance. Therefore it is important that the inlet water is filtered properly to minimize the wear of the pump.

The main filter must have a filtration efficiency of 99.98% at 10 µm. We recommend to use precision depth filter cartridges rated 10µm abs. β10>5000 (equivalent to a filtration efficiency of 99.98%). Bag filters and string wound filter cartridges typically have only 50% filtration efficiency.

This means that for each 100,000 particles reaching the filter, 50,000 particles pass through it compared to only 20 particles in a filter with an efficiency of 99.98%.

For more information on the importance of proper filtration, please consult our publication “Filtration” (code number 521B1009), which also will provide you with an explanation of filtration definitions and a guidance on how to select the right filter.

10. Dimensions

10.1 Pump

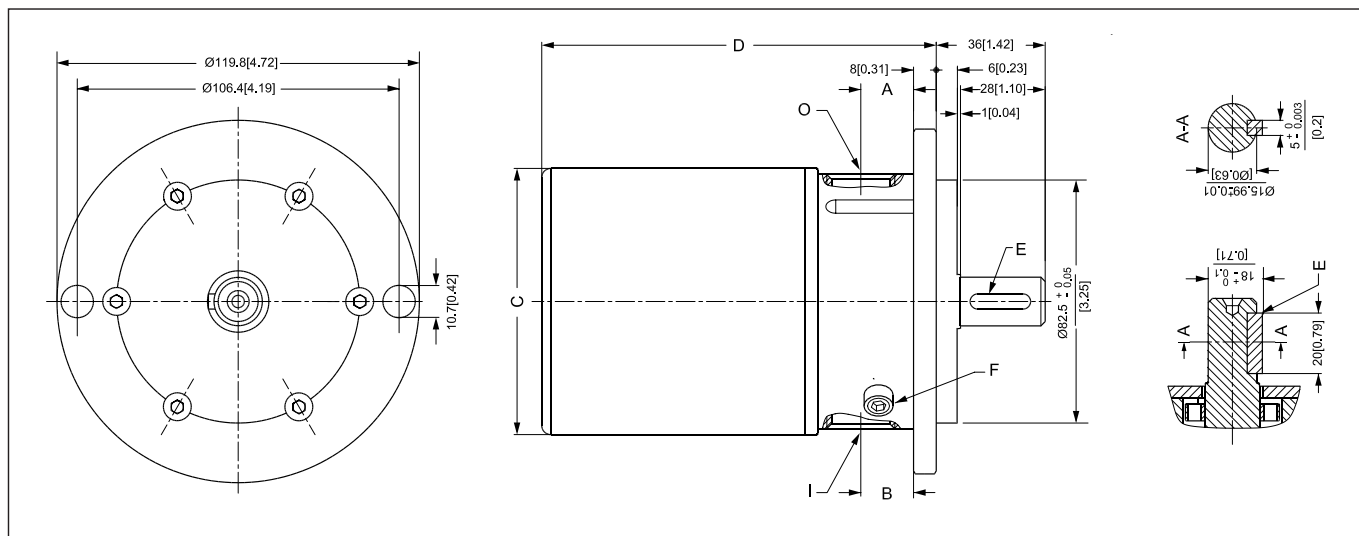

Description		APP 0.6 - APP1.0	
A	Port position, mm (in)	15.9 (0.63)	
B	Port position, mm (in)	15.9 (0.63)	
C	mm (in)	Ø 88 (3.5)	
D	mm (in)	131 (5.2)	
E	Parallel key, DIN 6885,	mm	5 × 5 × 20
		in	0.20 × 0.20 × 0.78
F	Bleeding	M6, Hexagon AF = 5 mm	
I	Inlet connection	BSP G½"; 15 (0.59) deep	
O	Outlet connection	BSP G½"; 15 (0.59) deep	
Pump mounting flange		SAE A 2	

10.2 Complete unit

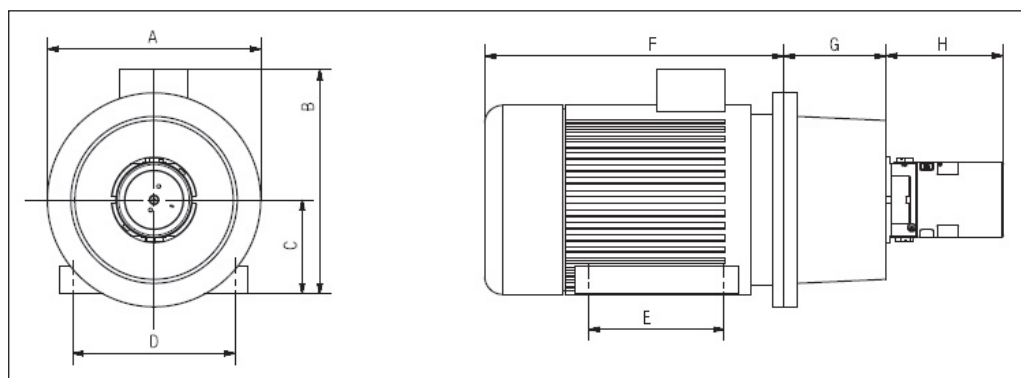

Examples of different pump/motor sizes. Check required power:

Pump	A (mm)	B (mm)	C (mm)	D (mm)	E (mm)	F (mm)	G (mm)	H (mm)	IEC Electric motor
APP 0.6	200	245	90	140	100	265	100	131	1.5 kW, IEC 90S-2
APP 0.8	200	245	90	140	125	290	100	131	2.2 kW, IEC 90L-2
APP 1.0	250	260	100	160	140	325	120	131	3.0 kW, IEC 100L-2

11. Installation

11.1 Mounting

The figure below illustrates how to mount the pump and connect it to electric motor/ combustion engine.

If alternative mounting is required, please contact Danfoss Sales Organization for further information.

To ensure easy mounting of the flexible coupling without using tools, the tolerances must be dimensioned accordingly.

Note: Any axial and/or radial loads on the shaft must be avoided.

The pump should be connected to the rest of the plant with flexible hoses.

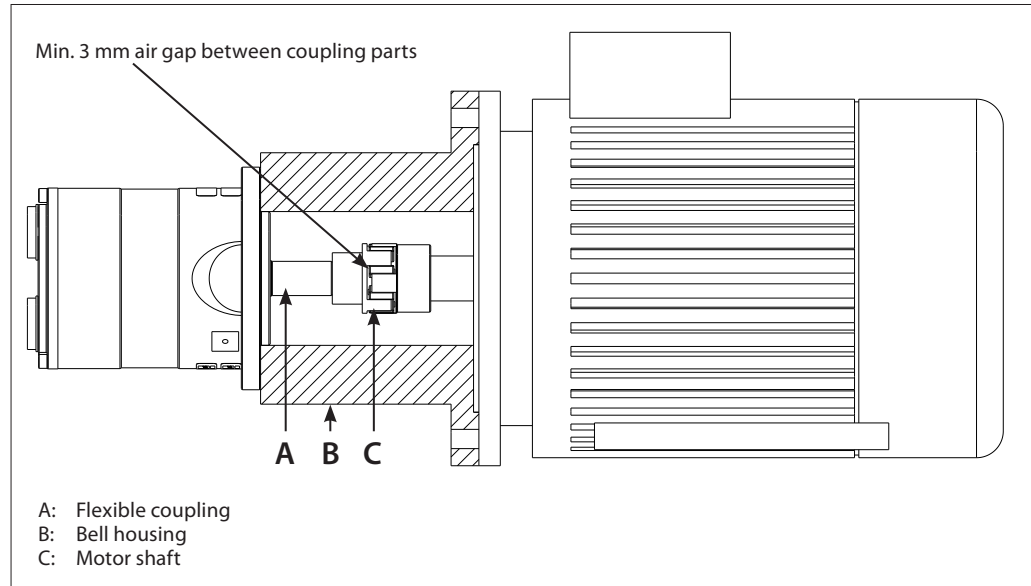

11.2 Open-ended system with direct water supply

In order to eliminate the risk of cavitation, a positive inlet pressure is always to be maintained. Please see technical data (section 3) for specific pressure values.

1. Place the filter (1) in the water supply line in front of the pump.
2. Place a monitoring pressure switch (2) - set at min. inlet pressure - between filter and pump inlet. The monitoring switch must stop the pump at pressures lower than min. inlet pressure. Please see technical data (section 3) for specific pressure values.

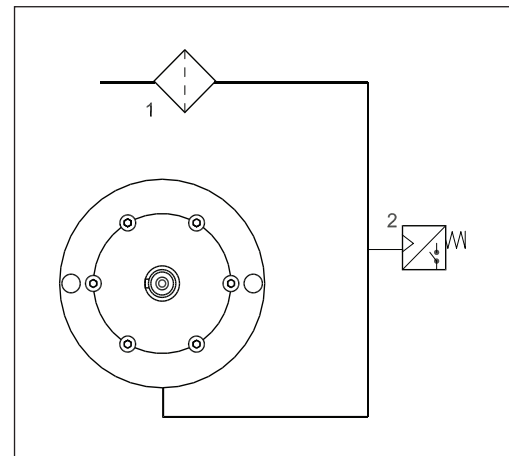

11.3 RO system with APP pump

1. Dimension the inlet line to obtain minimum pressure loss (large flow, minimum pipe length, minimum number of bends/connections, and fittings with small pressure losses).
2. Place an inlet filter (1) in front of the APP pump (2). Please consult section 9, "Filtration" for guidance on how to select the right filter. Thoroughly clean pipes and flush system prior to start-up.
3. Place a monitoring pressure switch (3) set at min. inlet pressure between filter and pump inlet. The monitoring switch must stop the pump at pressures lower than minimum pressure.
4. Use flexible hoses (4) to minimize vibrations and noise.
5. In order to eliminate the risk of damage and cavitation, a positive pressure at the inlet (5) is always to be maintained at min. inlet pressure and max. inlet pressure.
6. For easy system bleeding and flushing, a bypass non-return valve (6) is integrated in the APP pump.
7. A non-return valve (7) in outlet can be installed in order to avoid backspin of the pump. The volume of water in the membrane vessel works as an accumulator and will send flow backwards in case of the pump stops momentarily.
8. A safety valve (8) can be installed in order to avoid system damage as the Danfoss APP pump creates pressure and flow immediately after start-up, regardless of any counter-pressure.

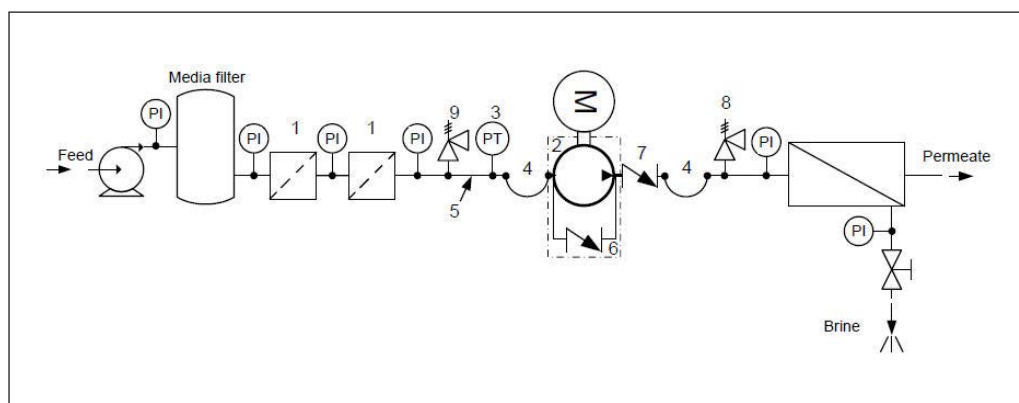

12. Service

12.1 Warranty

Danfoss APP pumps are designed for long operation, low maintenance and reduced lifecycle costs.

Provided that the pump has been running according to the Danfoss specifications, Danfoss guarantees 8,000 hours service-free operation, however, max. 18 months from date of production.

If Danfoss recommendations concerning system-design are not followed, it will strongly influence the life of the APP pumps.

12.2 Maintenance

After 8,000 hours of operation it is **strongly recommended to inspect the pump and change any worn parts, eg pistons and shaft seal.** This is done in order to prevent a potential breakdown of the pump.

If the parts are not replaced, more frequent inspection is recommended according to our guidelines.

Standstill:

The APP pumps are made of Duplex/Super Duplex materials with excellent corrosion properties. It is, however, always recommended to flush the pump with freshwater when the system is shut down.

12.3 Repair

In case of irregular function of the APP, please contact the Danfoss RO Solutions Sales Organisation.

Danfoss A/S
High Pressure Pumps
DK-6430 Nordborg
Denmark

Danfoss can accept no responsibility for possible errors in catalogues, brochures and other printed material. Danfoss reserves the right to alter its products without notice. This also applies to products already on order provided that such alterations can be made without subsequential changes being necessary in specifications already agreed. All trademarks in this material are property of the respective companies. Danfoss and the Danfoss logotype are trademarks of Danfoss A/S. All rights reserved.



Instruction

APP pump instruction

APP 0.6-1.0, APP 1.5-2.5 and APP 3.0-3.5



Instruction **APP pump instruction APP 0.6-1.0, APP 1.5-2.5 and APP 3.0-3.5**

APP pump instruction APP 0.6-3.5 (180R9065)	1.	Identification
Table of Contents	2.	System design
	2.1	Open-ended systems with water supply from a tank
	2.2	Open-ended systems with direct water supply
	2.3	Problems with reversing pumps
	2.4	General guidelines for calculation of pressure losses
	2.5	General comments on
	3.	Building up the pump unit
	3.1	Mounting
	3.2	Direction of rotation
	3.3	Orientation
	3.4	Protection from too high pressures
	3.5	Connections
	4.	Initial start-up
	5.	Operation
	5.1	Temperature
	5.2	Pressure
	5.3	Dry running
	5.4	Disconnection
	5.5	Storage
	5.5.1	Open-ended systems with water supply from tank
5.5.2	Open-ended systems with direct water supply	
6.	Service	
6.1	Periodic maintenance	
6.2	Repair	

1. Identification

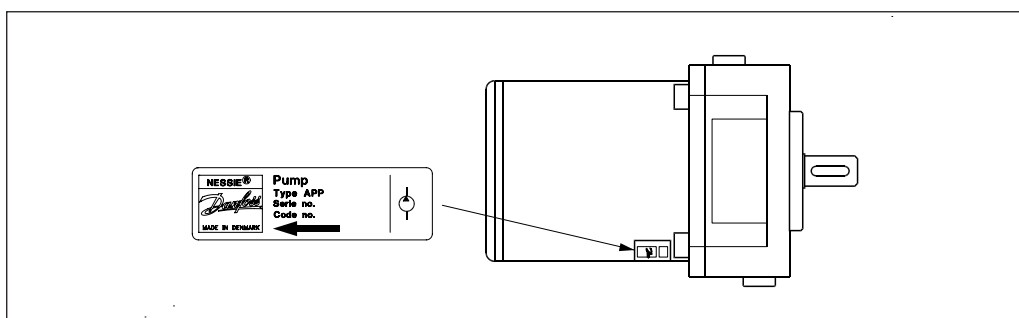

2. System design

The design of the system must ensure that self emptying of the pump during standstill is avoided.

The inlet pressure of the pump must never exceed the outlet pressure. This may typically occur in boosted or open-ended systems with direct water supply.

In order to avoid this it is recommended to install a pre-stressed check valve or a pressure switch in the pump inlet.

The opening pressure of the check valve must be bigger or equal to the inlet pressure.

2.1 Open-ended systems with water supply from a tank

(The numbers 1-3 refer to the drawing below.) In order to eliminate the risk of cavitation, observe the following guidelines:

- 1) Place the tank above the pump (water level in the tank should always be above the pump).
- 2) Place the inlet filter before the tank.
- 3) Dimension the inlet line to obtain minimum pressure loss (large flow area, minimum pipe length, minimum number of bends/connections, fittings with small pressure losses).

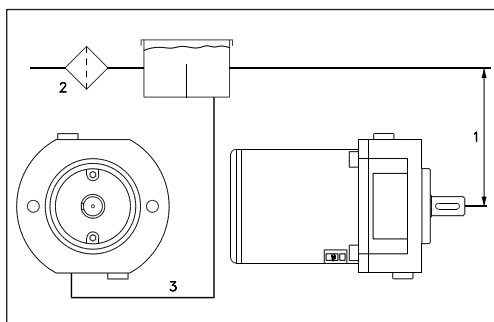

2.2 Open-ended systems with direct water supply

The pump is supplied with water direct from a booster pump.

The water pressure must not exceed 5 bar abs. (72.5 psi).

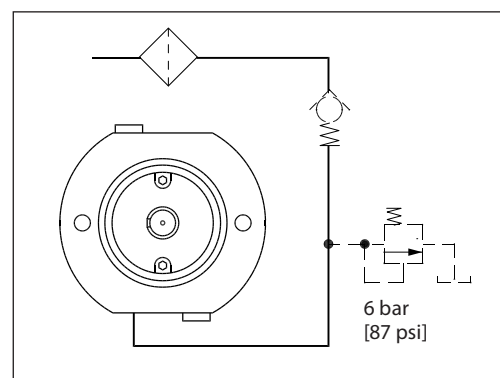

2.3 Problems with reversing pumps

If exposed to high pressure in the outlet while the electric motor is not energized, the pumps will start spinning backwards. This will not harm the pumps as long as the pressure in the inlet does not exceed the max. pressure of 5 bar.

If a non-return valve is mounted in the inlet line, a low-pressure relief valve will also be required. Alternatively a high-pressure check valve could be mounted in the pump discharge line to prevent the pump from reversing.

The dotted setup ensures that the inlet pressure does not exceed the 5 bar abs., when a non-return valve is mounted in the inlet.

2.4 General guidelines for calculation of pressure losses

In order to avoid the risk of cavitation, the inlet pressure at the pump must be in accordance with the specifications mentioned in Data sheet (521B0850).

The inlet line connection must be properly tightened, as possible entrance of air will cause cavitation.

The suction conditions can be optimized according to below guidelines.

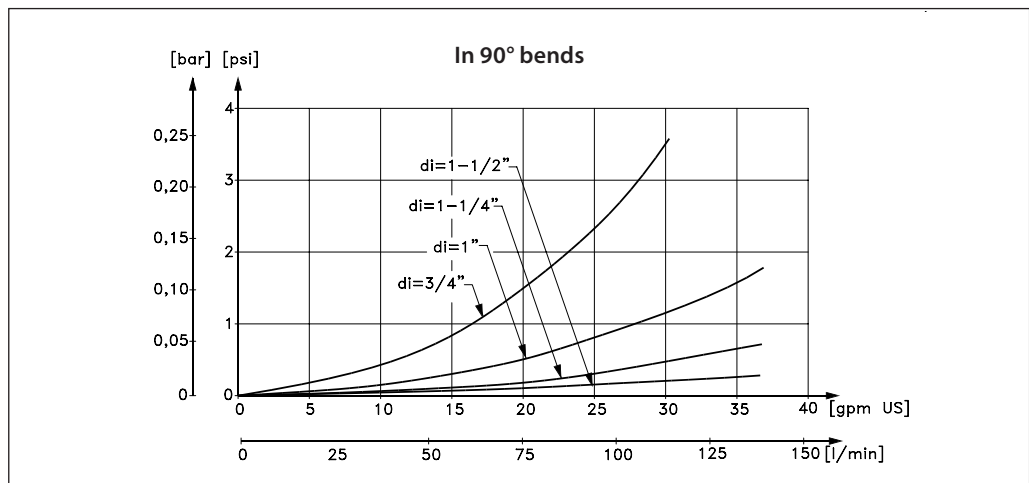
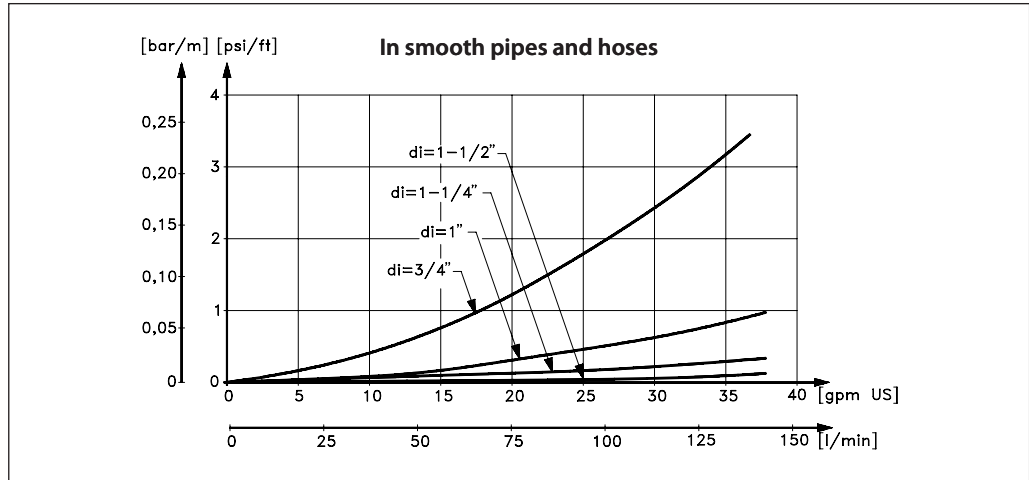

2.5 General comments on

Filtration

A good filtration is vital to ensure a long and trouble free life of the pump.

When selecting a filter or strainer, please note that filter materials should be compatible with water, i.e. should neither corrode or dissolve. Also be aware of the electrochemical series of the applied materials.

Main filter must have a fineness of 10 µm abs. β 10 >5000. The pressure loss across the filter should be monitored.

Water tank

Must be made of corrosion-proof material such as stainless steel or plastic and must be sealed to prevent entrance of impurities from the environment.

Automatic pressure equalization between tank and surroundings must be ensured.

Inlet from the water supply and inlet to the pump should be placed in opposite ends of the tank to calm and deaerate the water, and to ensure optimum opportunity for particles to settle.

Pump suction line should be placed relatively high above the tank bottom in order to prevent settled particles from being led into the pump.

We recommend a separation ("wall") to separate the inlet from the outlet end of the tank.

Monitoring

It is recommended to continuously monitor the following conditions:

- Water level in the tank
- Filter contamination
- Pressure (inlet- and outlet side of the pump)

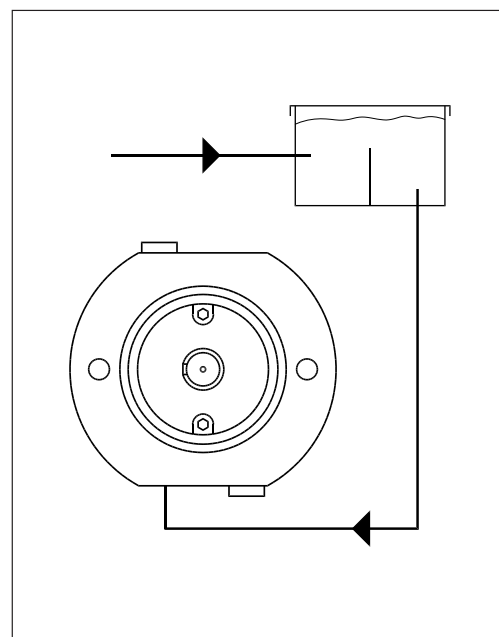

3. Building up the pump unit

3.1 Mounting

(Please also see hints in "Right and Wrong")

If alternative mounting is desired, please contact the Danfoss Sales Organization.

Choose proper tolerances to ensure an easy mounting of the elastic coupling without use of tools.

Please take care to observe the recommended length tolerances of the chosen coupling, as an axial force on the pump will damage the pump.

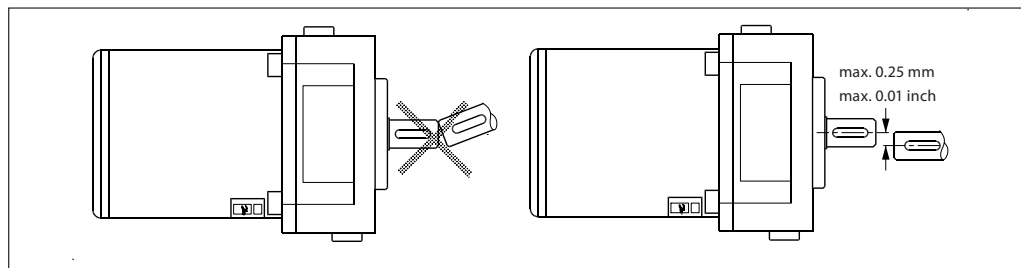
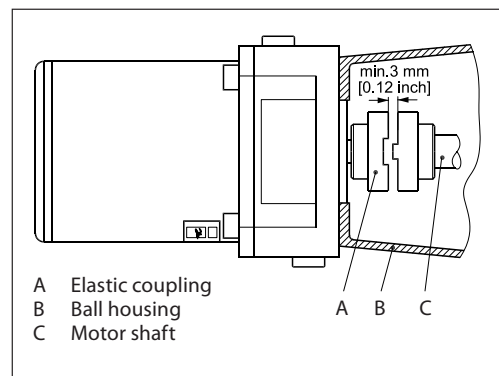

3.2 Direction of rotation

Is indicated by means of an arrow at the inlet side of the pump.

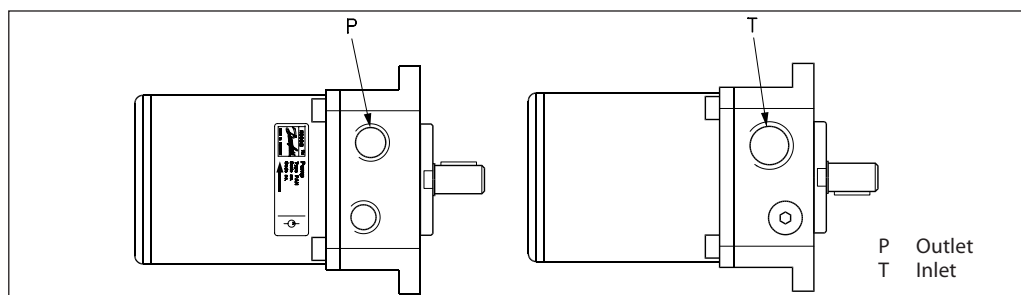

3.3 Orientation

The pump can be mounted/oriented in any horizontal direction. Vertically only with the shaft pointing upwards.

The valve should be placed as close to the pump as possible. The opening characteristics of the valve must not result in peak pressures higher than 200 bar (2900 psi).

3.4 Protection from too high pressures

The pump should be protected against too high pressure by means of a pressure relief valve or a bypass/unloading valve placed on the pressure side.

The valve outlet must not be connected directly to the pump suction line. It shall be connected directly to the tank.

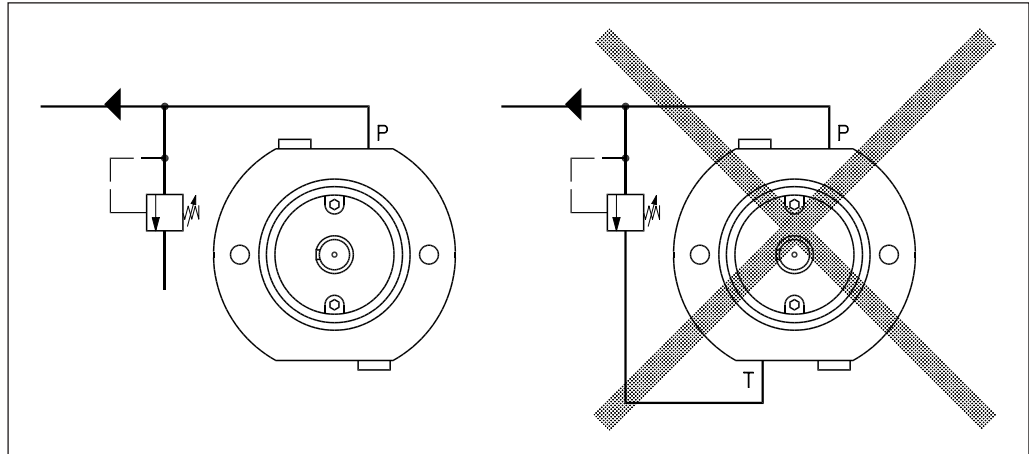

3.5 Connections

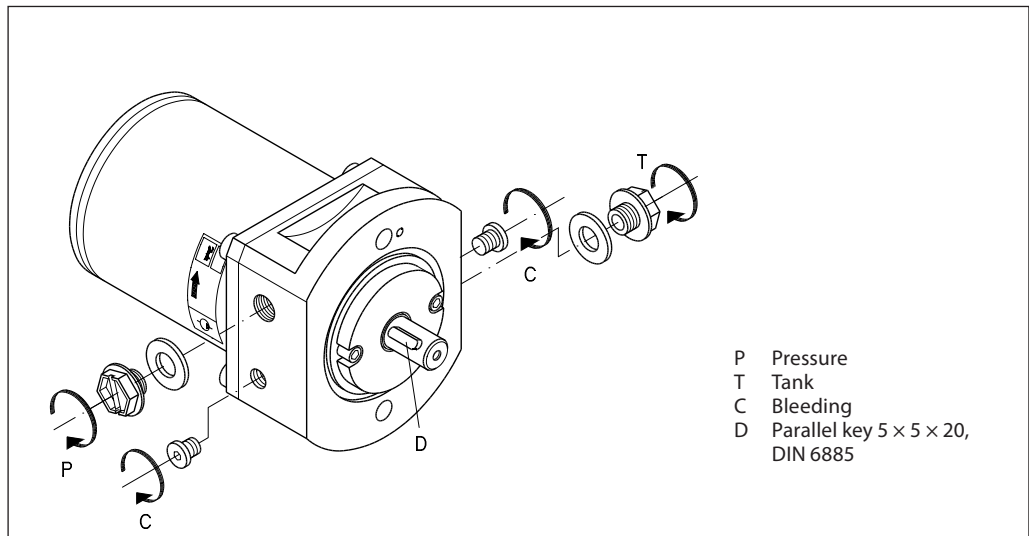

	APP 0.6-1.0			APP 1.5-2.5 and APP 3.0-3.5		
	P	T	C	P	T	C
Thread size	G 1/2 × 15	G 1/2 × 15	M6 Hexagon NV 4	G 1/2 × 15	G 3/4 × 17	G 1/4, NV 6 14 deep
Max tighten torque	25 Nm 18 (lbf ft)	25 Nm 18 (lbf ft)	5 Nm 3.5 (lbf ft)	25 Nm 18 (lbf ft)	25 Nm 18 (lbf ft)	15 Nm 11 (lbf ft)

Recommended torque values refer to steel washers containing a rubber sealing element.

4. Initial start-up

Before start-up, loosen the top bleeding plug "C". When water appears from the bleeding plug, retighten the plug. With its inlet line connected to the water supply or the tank, the pump is now started with open outlet port.

At the initial start of the system, the pump should be run without pressure for about 5 minutes, thus removing possible impurities from pipes, hoses, etc. **However, the system should be flushed before start-up – without the connected pump.**

WARNING:

Make sure that the direction of rotation of the electric motor corresponds to the direction of rotation of the pump. Otherwise the pump will be damaged if a check valve is placed between pump and tank.

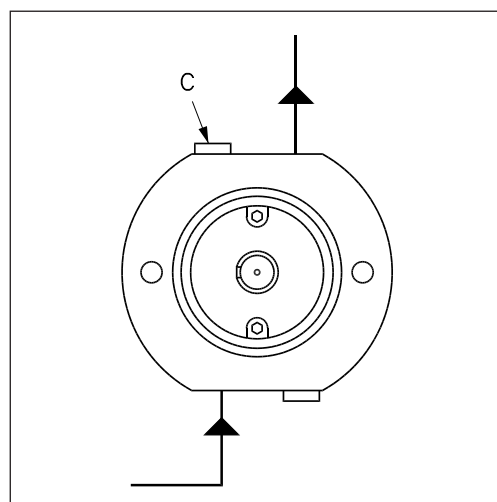
5. Operation
5.1 Temperature

Fluid temperature: Min. +3° C to max. +50° C

Ambient temperature: Min. 0° C to max. 50° C

In case of lower operating temperatures, please contact the Danfoss Sales Organization.

5.2 Pressure

The inlet pressure must be min. 0.9 bar (13 psi) and max. 5 bar (72.5 psi) abs. At lower pressures the pump will cavitate, resulting in damage to the pump.

Max. pressure on the pump's outlet line should be limited at 80 bar (1160 psi) continuously. Short-term pressure peaks (e.g. in connection with closing of a valve) of up to 100 bar (1450 psi) are acceptable.

NB:

The pump unit should include a pressure gauge on the high pressure side.

5.3 Dry running

When running, the pump must always be connected to the water supply in order to avoid damage if it should run dry.

In systems with water tank it is recommended to build in a level gauge in the tank to avoid the risk of running dry.

5.4 Disconnection

If the inlet line is disconnected from the water supply, the pump will be emptied of water through the disconnected inlet line.

When starting up again, follow the bleeding procedure described under section 4: Initial start up.

5.5 Storage

Storage temperature: Min. -40° C to max. +70° C
--

When preparing the pump for long-term storage or for temperatures below the freezing point, flush the pump with an anti-freeze medium type monopropylene glycol to prevent internal corrosion or frost in the pump.

For further information on anti-freeze media, please contact the Danfoss Sales Organization.

Recommended procedure:
5.5.1 Open-ended systems with water supply from tank

1. Empty the tank of water and empty the pump housing through the lower bleeding plug. When the pump is empty, retighten the plug.
2. Through the upper bleeding plug, fill the pump housing with anti-freeze medium. Pour anti-freeze medium into the tank. Connect a hose to the outlet of the pump and lead the other end of the hose back to tank.
3. Quickly start and stop the pump. Make sure that the pump does not run dry. The pump is now protected against internal corrosion and frost.

5.5.2 Open-ended systems with direct water supply

1. Disconnect the water supply to the pump.
2. Through the lower bleeding plug, empty the pump housing of water and close it again.
3. Connect the pump to a tank of e.g. 25 litre 6 gal. of anti-freeze additive. Connect a

hose to the inlet port of the pump and via another hose return the flow from the outlet port to the tank with anti-freeze additives.

4. Quickly start and stop the pump. Make sure that the pump does not run dry. The pump is now protected against internal corrosion and frost.
-

6. Service**6.1 Periodic maintenance**

The APP pump is designed so that lubrication follows from the water itself and there is thus no oil in the pump.

The pump requires no periodic replacements of seals and valve parts.

6.2 Repair

In case of irregular function in the pump, please contact the Danfoss Sales Organisation.

Danfoss A/S

High Pressure Pumps
DK-6430 Nordborg
Denmark



Electric Motors

Motor Manual

hoyermotors.com

Manual

HOYER ▶

MOTORS

180R9230

1. General

This manual concerns the following types of standard induction motors from Hoyer:

HMA2, HMC2, HMD, HMT, MS, Y2E1, Y2E2, YDT

These motors are manufactured in accordance with IEC/EN 60034-4 and IEC/EN 60072.

Motors are rated for the ambient temperature range -20°C to +40°C and site altitudes ≤1000 m above sea level.

Low-voltage motors are components for installation in machinery. They are CE marked according to the Low Voltage Directive 2006/95/EC

2. Transport and storage

Check the motor for external damage immediately upon receipt and, if found, inform the forwarding agent right away. Check all rating plate data, and compare it with the requirement of the motor.

Turn the shaft by hand to check free rotation, remove transport locking if used.

Transport locking must be used again for internal transport also. It is also important that transport locking is used when motors are transported mounted on equipment.

All motors should be stored indoors, in dry, vibration- and dust-free conditions.

Lifting eyebolts must be tightened before use. Damaged eyebolts must not be used, check before use. Lifting eyes at motor must not be used to lift the motor when it is attached to other equipment.

Before commissioning, measure the insulation impedance. If values are ≤ 10M at 25°C, the winding must be oven dried. The insulation resistance reference is halved for each 20°C rise in motor temperature.

It is recommended that shafts are rotated periodically by hand to prevent grease migration.

3. Installation

The motor must be fixed on a stable, clear and flat foundation. It must be sufficiently rigid to withstand possible short circuit forces.

It is important to ensure that the mounting conditions do not cause resonance with the rotational frequency and the doubled supply frequency.

Only mount or remove drive components (pulley, coupling, etc.) using suitable tools, never hit the drive components with a hammer as this will cause damage to the bearing.

The motor are balancing with half key, ensure that the drive components are also the same.

Correct alignment is essential to avoid bearing, vibration and shaft failure.

Use appropriate methods for alignment.

Re-check the alignment after the final tightening of the bolts or studs.

Check that drain holes and plugs face downwards. We recommend opening the drain hole for motors placed outdoors and not running 24 hours / day, so that the motor can breathe, thus ensuring a dry motor.

4. Electrical connection

Work is only permitted to be carried out by qualified specialists and must to be carried out in accordance with local regulations.

Before work commences, ensure that all power is switched off and cannot be switched on again. This also applies to the auxiliary power circuits, e.g. anti-condense heaters.

Check that supply voltage and frequency are the same as rated data.

Motors can be used with a supply deviation of ± 5% voltage and ± 2% frequency, according to IEC60034-1

Connection diagrams for main supply and accessory as PTC or heater are located inside the terminal box.

Connections must be made in such a way as to ensure that a permanently safe electrical connection is maintained, both for the main supply and the earth connection.

We recommend that crimped connections are made in accordance with IEC 60352-2.

Tightening torques for terminal board screws:

Thread	M5	M6	M8	M10	M12	M16	M20
T.(Nm)	2.5	3.5	7	12	18	35	55

Ensure that the terminal box is clean and dry.

Unused glands must be closed.

Check the terminal box gasket before it is remounted.

5. Maintenance

Inspect the motor at regular intervals, keep it clean and ensure free ventilation air flow, check the condition of shaft seals and replace if necessary. Both electrical and mechanical connections must be checked and tightened if necessary.

Bearing size and type are specified on the rating plate. Motor types HMA2 and HMC2 is as standard with lifetime greased bearing with motor size ≤ 225 .

Motor types MS and Y2E is as standard with lifetime greased bearing with motor size ≤ 160 .

Typical duty hours for lifetime lubricated bearings.

Frame size	Poles	Typical lifetime
56 – 160	2 – 8	40.000h
180	2	35.000h
200	2	27.000h
225	2	23.000h
180 – 225	4 – 8	40.000h

Motors with a re-greasing system must be lubricated with high quality lithium complex grease, NLGI grade 2 or 3, with a temperature range of between -40°C to $+150^{\circ}\text{C}$.

Motors are normal fitted with a data plate with greasing information; if it is missing use the following re-greasing intervals.

Frame size	Grease (g)	2 pole (h)	4 pole (h)	6 pole (h)	8 pole (h)
160	20	4200	7000	8500	8500
180	20	4200	7000	8500	8500
200	25	3100	6500	8500	8500
225	25	3100	6500	8500	8500
250	35	2000	6000	7000	7000
280	35	2000	6000	7000	7000
315	50	1500	5500	6500	6500
355	60	1000	4000	5000	6000
400	80	800	3000	4000	6000

Grease the motor while running, open the grease outlet plug and let the motor run 1-2 hours before the outlet grease plug is closed again.

Grease the motor for the first time during commissioning.

The following applies in general for both lifetime lubricated and re-lubricated bearings:

At 60Hz the time will be reduced by app. 20%.

Data for vertically mounted motors are half of the above values.

The table values are based on an ambient temperature of 25°C . The values must be halved for every 15K increase in bearing temperature.

Higher speed operations, e.g. frequency converter drive will require shorter greasing intervals. Typically, doubling the speed will reduce the values by 50%.

6. Special note for Atex Zone 22 motors.

Notice for the use of electrical equipment in areas with combustible dust.

Designation of motor according to EC directive:

Ex II 3D T125°C, IP55.

The dust hazardous 3-phase asynchronous motors are in accordance with European standard EN 50281-1-1. Combustible dust areas will be found in agricultural areas and in industrial environments.

Only one electrical installation may be installed in one specified area (zone).

Only certificated cable glands for category 2D may be used. Unused glands must be closed.

Connections must be made in such a way as to ensure that a permanently safe electrical connection is maintained, both for the main supply and earth connection.

Installations must be in accordance with actual standards for installation in the Zone 22 area.

It is recommended that EN 50281-2 is followed according temperature and dust on the motor surface.

The use of motors with so much surface dust that the motor temperature increases is not permitted.

Regularly cleaning is recommended.

The radial shaft sealing ring is part of the ATEX certification. It is important that the ring is always intact.

The shaft sealing must be regularly checked, and if dry it must be lubricated. It is recommended that the seal is re-lubricated regularly.

Always use the original seal ring when replaced.

Replacing bearings also means replacing the seals.

All machines must be inspected regularly for mechanical damage.

The user is responsible for changing parts in accordance with the lifetime of parts, in particular:

bearings, grease and lubrication of shaft sealing.

Maintenance, repairs and replacement on zone 22 motors must only be carried out by qualified specialists.

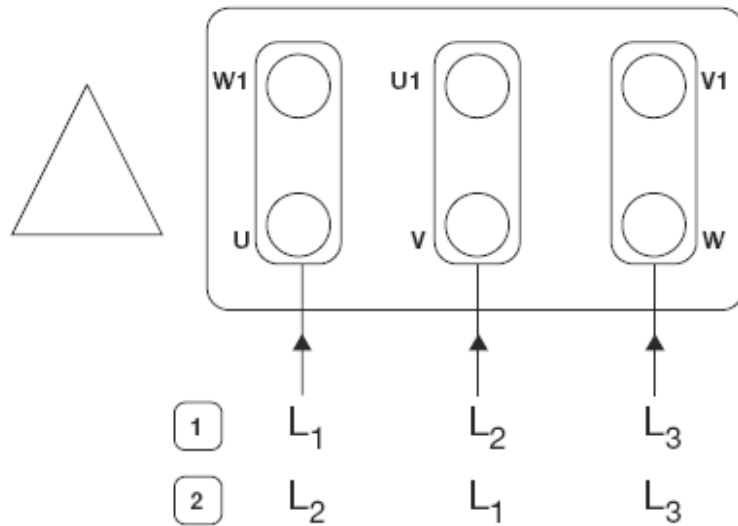

Connection diagram
Anschlußdiagramm
Anslutningdiagramm
Forbindelsesdiagramm
Aansluitdiagramm
Connection
Conexión
Collegamento
Схема соединений
Schemat polaczeń

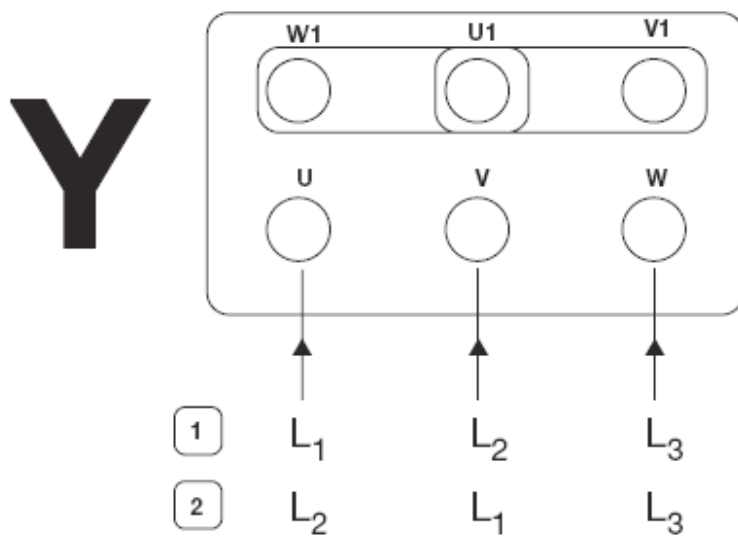

Instruction

Recommended service intervals for APP pumps



Instruction **Recommended service intervals for APP pumps**

Recommended service intervals for APP pumps (180R9199)

1. General information

2. Design/features

Table of Contents

 3. Appendix 1

1. General information

This guideline provides information on the recommended service intervals. The recommendation is based upon good engineering practice and on experience gained from operation even under extreme conditions.

The recommendation is for guidance only.

2. Design/features

Danfoss APP pumps are designed for long operation and low maintenance and life cycle costs.

If the Danfoss recommendations concerning system-design (see our data sheet) are not followed, the service life of the APP pumps might be affected.

Danfoss guarantees 8,000 hours service free operation, however max. 18 months from date of production. After 8,000 operation hours it is recommended to inspect the pump and replace worn parts, if any.

The recommended service intervals on the different parts in the APP pumps appear from the table below:

Pos.	Qty.	Description	Material	Service interval
1	1	Housing, main bearing	Duplex, PEEK	No need for service
11, 125, 211*	1	Mounting flange/ end flange	Wetted part: Duplex Dry part: AISI 316L	No wear part
121, 181*	1	Port flange	Duplex	No wear part
31	1	Swash plate	Super Duplex	40,000 hours
66	5/7/9	Piston	Super Duplex and PEEK	Recommended inspection on a yearly basis and evaluated acc. to app. 1
92	1	Valve plate	Super Duplex	24,000 hours
91	1	Port plate	Super Duplex, PEEK	24,000 hours
61	1	Cylinder barrel	Super Duplex	40,000 hours
65	1	Retainer plate	Super Duplex	24,000 hours
64	1	Retainer ball	Super Duplex	40,000 hours
71	1	Retainer guide	Super Duplex	40,000 hours
62	1/4	Spring	Duplex	40,000 hours
63	1	Spring guide	Duplex or PP	40,000 hours
142	1	Stop for shaft seal	PP	No wear part
124, 215*	1	Shaft seal	Hastelloy and NBR	It is good practice to change the seal after each disassembly of the pump
125	1	Cover for shaft seal	Super Duplex	No wear part
93	5/7/9	Back-up ring	PTFE	24,000 hours
*		O-ring (overall)	NBR	24,000 hours
*		Screw (overall)	AISI 316	No wear part
*		Pin (overall)	AISI 316, Duplex or PEEK	No wear part
152	1	Valve cone (flushing valve)	Duplex or PEEK	40,000 hours
3, 129*	2	Bleeding screw	Duplex	No wear part
67	1	Key	AISI 316	40,000 hours

* depends on pump size

3. Appendix 1

Pistons:

The pistons are the heart of the pump regarding service.

If the pistons break down, the pump will suffer a breakdown.

In case of doubt - the pistons must be replaced.

The pictures below is ment as a guideline for evaluating the wear of the sliding surface.



Cavitation of the piston shoes.
New inspection is required in 3,000-4,000 hours.



Cavitation of the piston shoes.
All pistons must be replaced within the next 500-1,000 hours.



Cavitation of the piston shoes.
All pistons must be replaced within the next 100-200 hours.



Cavitation of the piston shoes.
All pistons must be replaced immediately.

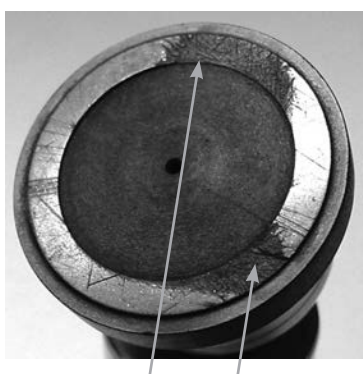

Abrasive wear of the piston shoes.
All pistons must be replaced immediately.

Danfoss A/S
High Pressure Pumps
DK-6430 Nordborg
Denmark

Danfoss can accept no responsibility for possible errors in catalogues, brochures and other printed material. Danfoss reserves the right to alter its products without notice. This also applies to products already on order provided that such alterations can be made without subsequential changes being necessary in specifications already agreed. All trademarks in this material are property of the respective companies. Danfoss and the Danfoss logotype are trademarks of Danfoss A/S. All rights reserved.

Parts list

APP Pumps

APP 0.6-1.0, APP 0.6-1.0 Compact

APM 0.8-1.2



APP 0.6-1.0

APP 0.6 - 1.0 Compact

Note:
The parts listed are not sold separately.

Exploded view, see next page.

Pos.	Qty.	Designation	Material	180B4187 – Seal / Flushing valve set (APP 0.6-1.0 Compact)	180B4186 – Cylinder barrel set (APP 0.6-1.0 Compact)	180B4183 – Valve plate set (APP 0.6-1.0 Compact)	180B4182 – Retainer set (APP 0.6-1.0 Compact)	180B4181 – Piston set (APP 0.6-1.0 Compact)	180B4184 – Swash plate set (APP 0.6 Compact)	180B4189 – Swash plate set (APP 1.0 Compact)
1	1	Housing	Duplex							
5	5-10	Screw M6x12	AISI 316	x				x		
31	1	Swash plate	Super Duplex						x	x
35	1	Bearing	PEEK						x	x
36	1	O-ring Ø53x1.5	NBR	x				x		
61	1	Cylinder barrel	Super Duplex / PEEK		x					
62	1	Spring	Duplex				x			
64	1	Retainer ball	Super Duplex				x			
65	1	Retainer plate	Super Duplex				x			
66	5	Piston	Super Duplex / PEEK					x		
67	1	Key (3x3x12)	AISI 316	x						
91	1	Port plate	Super Duplex / PEEK			x				
92	1	Valve plate	Super Duplex			x				
93	5	Back-up ring	PTFE	x		x				
94	5	O-ring (Ø8.73x1.78)	NBR	x		x				
121	1	Port flange	Duplex							
122	1	O-ring (Ø53x1.5)	NBR	x						
124	1	Shaft seal	AISI 316/NBR	x						
126	1	Pin (Ø4x9)	PEEK	x						
140	1	Bearing	PEEK	x						
142	1	Washer for shaft seal	PP	x						
151	1	O-ring	NBR	x						
152	1	Valve cone	PP	x						
153	1	Spring	Duplex	x						
154	1	Plug/guide	Duplex	x						
155	1	O-ring	NBR	x						
156	1	Locking ring	AISI 316	x						
		Instruction		x	x	x	x	x	x	x

Exploded view
APP 0.6 - 1.0 Compact

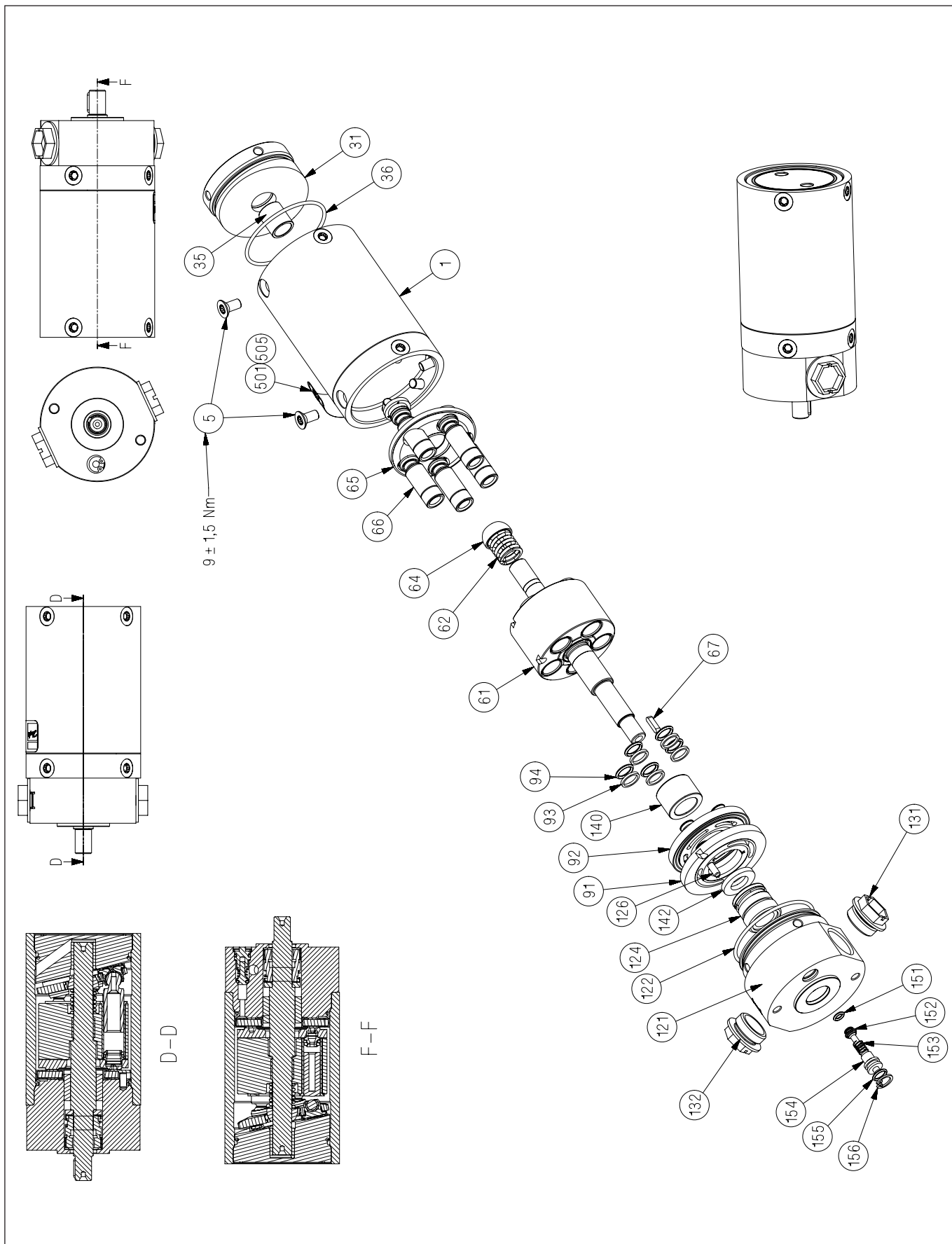

**APP 0.6 - 1.0 and
APM 0.8 - 1.2**

Note:
The parts listed are not sold separately, only in various kits.

Parts for APM 0.8-1.2 are equivalent to the parts for APP 0.6-1.0 except for valve plate sets.

Exploded view, see next page.

Pos.	Qty.	Designation	Material	180B4141 – Seal / Flushing valve set (APP 0.6-1.0)	180B4140 – Cylinder barrel set (APP 0.6)	180B4139 – Valve plate set (APP 0.6-1.0)	180F4100 – Valve plate set (APM 0.8 - 1.2)	180B4138 – Retainer set (APP 0.6-1.0)	180B4137 – Piston set (APP 0.6-1.0)
1	1	Housing	Duplex / PEEK						
2	1	Pin (Ø4x14)	AISI 316	x					x
61	1	Cylinder barrel	Super Duplex / PEEK		x				
62	1	Spring	Duplex					x	
63	1	Spring guide	PEEK					x	
64	1	Retainer ball	Super Duplex					x	
65	1	Retainer plate	Super Duplex					x	
66	5	Piston	Super Duplex / PEEK						x
67	1	Key (5x5x20)	AISI 316	x					
91	1	Port plate	Super Duplex / PEEK			x	x		
92	1	Valve plate	Super Duplex			x	x		
93	5	Back-up ring	PTFE	x		x	x		
94	5	O-ring (Ø8.73x1.78)	NBR	x		x	x		
121	1	Port flange	Duplex						
122	1	O-ring (Ø68x2)	NBR	x					x
123	1	O-ring (Ø40x2)	NBR	x					x
124	1	Shaft seal	AISI 316/NBR	x					
125	1	Mounting flange	Wetted part: PP Dry parts: AISI 316						
126	1	Pin (Ø4x9)	PEEK	x					
127	6	Screw M6x40	AISI 316	x					x
130	2	O-ring (Ø4.5x1.5)	NBR	x					
152	1	Valve cone	PEEK	x					
153	1	Spring	Duplex	x					
154	1	Plug/guide	Duplex	x					
155	1	O-ring (Ø7.0x1.5)	NBR	x					
	1	Instruction		x	x	x	x	x	x

Exploded view
 APP 0.6 - 1.0
 APM 0.8 - 1.2

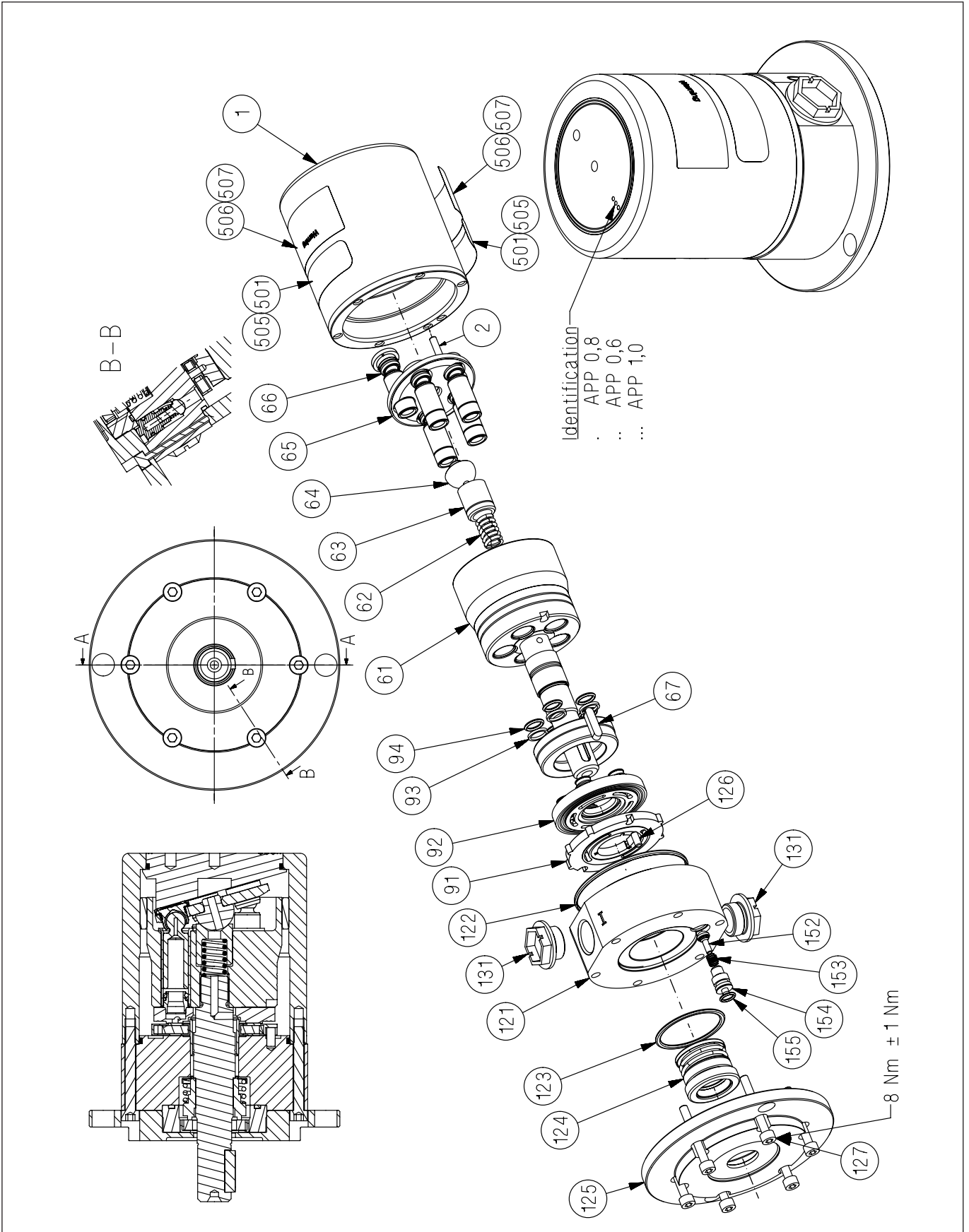

Tool sets

Note:
The parts listed are not sold separately, only in various kits.

Designation	180B4188 – Tool set (APP 0.6-1.0 Compact)	180B4142 – Tool set (APP 0.6-1.0)	180B4148 – Tool set (APP 1.5-3.5)	180B4162 – Tool set (APP 5.1-10.2)	180B4230 - Tool set (APP 11-13)	180B4222 – Tool set (APP 16-22)	180B4172 – Tool set (APP 21-38)
Shaft bush	x						
Press bush	x						
Drift	x						
Torx T30	x						
Shaft bush Ø18		x	x				
Press Bush Ø18		x	x				
Allen Key 4mm		x					
Allen Key 5mm			x				
Allen Key 6mm				x	x	x	x
Shaft bush Ø35				x			
Shaft seal extractor Ø35				x	x		
Press bush Ø35				x	x		
Adjustable pin wrench				x	x	x	x
Combination wrench 10mm				x	x	x	x
Combination wrench 13mm					x	x	x
Nut M8x6.5x13					x	x	x
Guide bolt M8x140mm							x
Shaft seal extractor Ø45						x	x
Press Bush Ø45						x	x
Eye bolt M8						x	x
Press bush for valve plate						x	x
Stop for retainer plate							x
Screw M8x20					x	x	x
Screw M8x70						x	x
Screw M8x140					x		
Lifting eye					x		

Danfoss A/S
High Pressure Pumps
DK-6430 Nordborg
Denmark

Danfoss can accept no responsibility for possible errors in catalogues, brochures and other printed material. Danfoss reserves the right to alter its products without notice. This also applies to products already on order provided that such alterations can be made without subsequential changes being necessary in specifications already agreed. All trademarks in this material are property of the respective companies. Danfoss and the Danfoss logotype are trademarks of Danfoss A/S. All rights reserved.

Guideline

Trouble shooting guide for APP pumps



Instruction	Trouble shooting guide for APP pumps
-------------	--------------------------------------

Trouble shooting guide for APP pumps	Trouble shooting fish bone chart
---	----------------------------------

Table of Contents	<ol style="list-style-type: none"><li data-bbox="411 288 737 324">1. No flow/no pressure<li data-bbox="411 342 858 378">2. Reduced flow/reduced pressure<li data-bbox="411 396 836 432">3. High torque on electric motor<li data-bbox="411 450 711 486">4. Noise from pump<li data-bbox="411 504 762 539">5. Noise from installation<li data-bbox="411 557 743 593">6. Typical signs of wear<ol style="list-style-type: none"><li data-bbox="411 589 644 624">6.1 Valve plate<li data-bbox="411 620 635 656">6.2 Port plate<li data-bbox="411 651 655 687">6.3 Swash plate
--------------------------	---

Trouble shooting fish bone chart

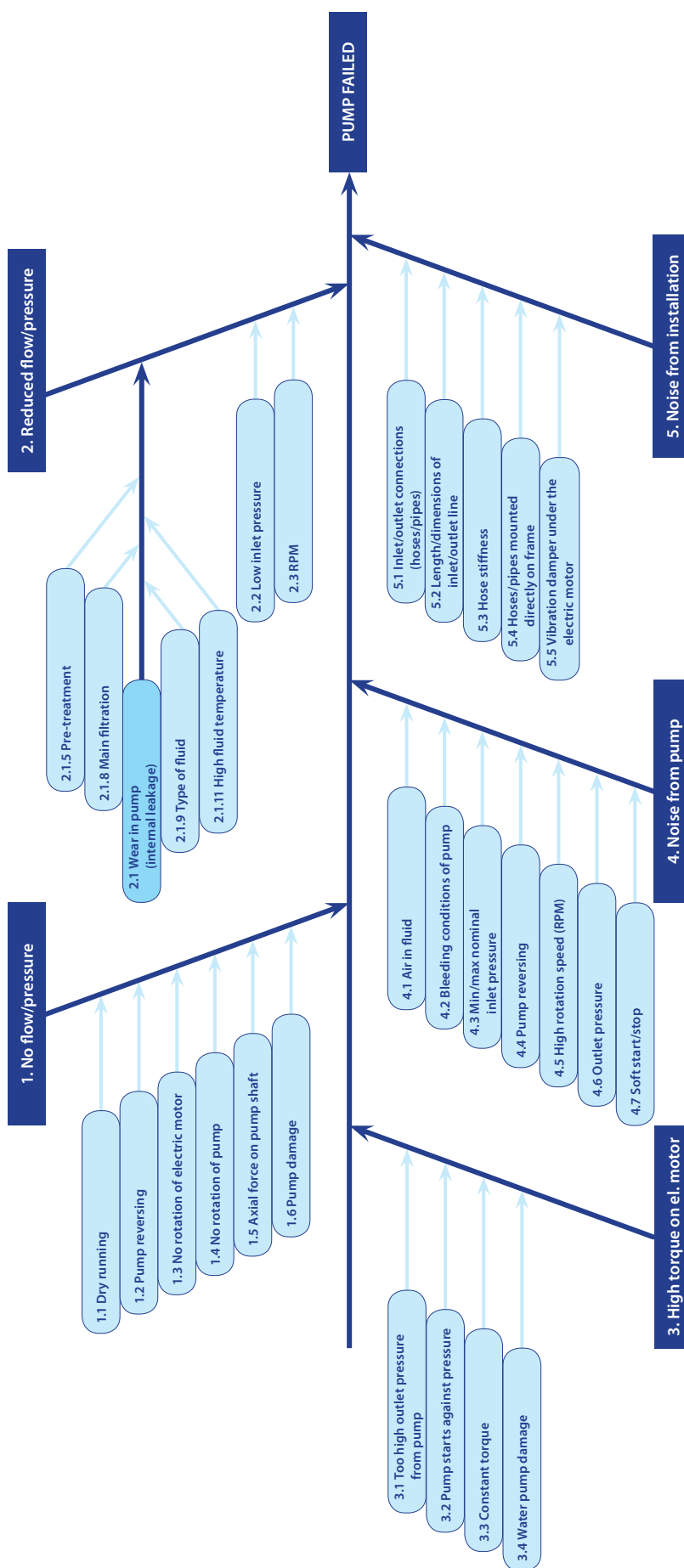

Instruction Trouble shooting guide for APP pumps

1. No flow/no pressure

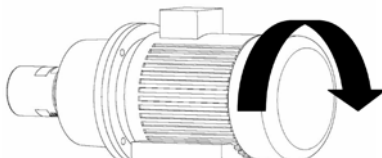
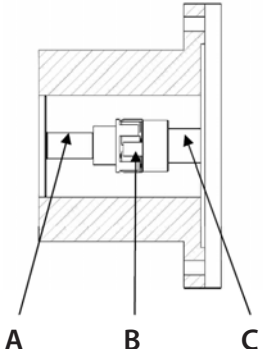
Cause	Remedy	Comments
1.1 Dry running (no water supply to the pump)	If no water comes out of the pump: 1.1.1 Check that inlet valve is open. 1.1.2 Check that booster pump is running.	Mount a low pressure switch in front of the pump and check its set point/ function. The low pressure switch ensures that the pump does not start until the inlet pressure has reached minimum inlet pressure (see Data sheet)
1.2 Pump reversing (electric motor is running the wrong direction, i.e. counter-clockwise)	1.2.1 Change the phase on the electric motor to make it run clockwise. WARNING: - The pump must not run without water for more than a few seconds. - If the pump takes in water from the high-pressure outlet line, it builds up pressure in pump housing and will eventually break down.	Rotation direction for the APP pump is shown by an arrow on the sticker on the side of the pump. 
1.3 No rotation of electric motor	1.3.1 Check that main switch is switched on. 1.3.2 Check the electricity at the facility. 1.3.3 Ensure that motor relay is switched on. 1.3.4 Ensure that fuse is not blown. 1.3.5 Ensure that booster pump is started. 1.3.6 Check that the monitor switches are working correctly. 1.3.7 Disconnect pump from electric motor and check that the motor is capable of running with no load.	If motor-type relay or the electrical fuse is blown, check that electric motor is sized correctly.
1.4 No rotation of pump	1.4.1 Ensure that coupling between electric motor and pump is connected. 1.4.2 Check if coupling is damaged. 1.4.3 Check that electric motor is sized correctly 1.4.4 Check that the electrical installation is correctly sized. 1.4.5 Contact Danfoss Sales office for guidelines in how to troubleshoot internal pump parts.	
1.5 Axial load on pump shaft (may cause high internal leakage) Only applying to APP 0.6 to APP 3.5 and APP 21 to APP 26 only	1.5.1 Ensure that the air gap between the two coupling parts is min 5 mm. It should always be possible to move the plastic part on the coupling at least 3 mm.	To ensure easy mounting of the flexible coupling without using tools, the tolerances must be dimensioned accordingly. WARNING: Any axial and/or radial loads on the shaft must be avoided. Any axial or radial load will cause breakdown.  <p> A Flexible coupling B Bell housing C Motor shaft </p>
1.6 Pump damage (the internal parts may be damaged)	1.6.1 Contact Danfoss sales office for guidelines in how to troubleshoot internal pump parts.	Instructions on internal elements 180R9092/180R9085 for APP 0.6-1.0 180R9091/180R9147/180R9089 for APP 1.5-3.5 180R9093/180R9090 for APP 5.1-10.2 180R9228/180R9227 for APP 11-13 and APP 16-22 180R9121/180R9139 for APP 21-38 – are available on www.ro-solutions.com .

2. Reduced flow/reduced pressure

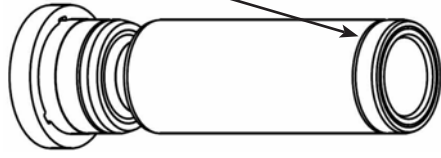
Cause	Remedy	Comments
2.1 Wear on pump Large internal leakage due to: - Pre-treatment - Main filtration - Fluid type - High fluid temperature	2.1.1 Dismantle the pump. 2.1.2 Check valve plate. Valve plate has marks/scratches on the surface facing the port plate. Minor wear on valve plate can cause large internal leakage. See Index 6.1 2.1.3 Check port plate. Port plate has marks/scratches on the surface facing the valve plate. Minor wear on port plate can cause large internal leakage. See Index 6.2 2.1.4 Check cylinder barrel. Liners in cylinder barrel may be scratched or worn. Insert a piston in the liner and check the fit. If there is any space (clearance) between liner and piston, liner or piston is worn. 2.1.5 Analyse fluid for content of particles. 2.1.6 Check that filters are OK and working correctly. 2.1.7 Install correct pre-filter (1µm nom. string-wound filter). 2.1.8 Check that the correct filter type is used (particles in fluid must not exceed 10 µm). Danfoss RO Solutions supply filters. Please contact Danfoss sales office. 2.1.9 The APP pump is designed for seawater operation; for any other fluid, please contact Danfoss sales office for further help. 2.1.10 If fluid temperature is above 50°C, stop the pump immediately. 2.1.11 Check internal parts (see above).	See instruction on replacement criteria (521B0925). Are available on www.ro-solutions.com Typical signs of wear: Polished surface all over the swash plate. Normally, only half of the swash plate = the pressure side is polished. See index 6.3. If the ring is missing, the piston is very worn.  The filters can be bypassed, even if they are correctly mounted. Some filters can create channelling where particles can pass through the filter in tunnels. String wound filters are typically channelling filters. A string wound filter may have a filtration efficiency of only 50%, which will cause internal wear and must always be followed by a main filter. Insufficient filtration means that too many or too large hard particles can pass the main filter because it is damaged, bypassed or simply too poor. Filtration efficiency must be 99.98% (Beta = 5000) at 10 µm to prevent abnormal wear of the pump. Temperature > 50°C will cause wear on internal pump parts. Mount a temperature switch and check its set point / function. The temperature switch will ensure that the pump stops at fluid temperatures > 50°C.
2.2 Low inlet pressure	2.2.1 Check that booster pump supplies the right pressure/flow. 2.2.2 Check if filters require replacement.	If the pressure drop across the filters is too high, the booster pump does not deliver sufficient flow/pressure. No pressure or low pressure results in cavitation and insufficient internal lubrication causing wear on internal pump parts. Mount a low-pressure switch before the pump and check its set point/ function. The low-pressure switch ensures that the pump does not start until the inlet pressure has reached 1 bar.
2.3 Rotation speed (RPM)	2.3.1 If VFD-operated, check frequency. 2.3.2 Check that rotation speed of the electric motor is as stated on name plate on electric motor. Check that the motor rotor winding is not damaged.	Speeds below 700 rpm result in insufficient internal lubrication causing wear on the internal pump parts.

4. Noise from pump

Cause	Remedy	Comments
4.1 Air in fluid	4.1.1 Ensure that the entire inlet line is bled before starting up the system. 4.1.2 Ensure that air cannot enter into the inlet line.	Small air bubbles will accumulate and create large bubbles causing internal cavitation and thus making the pump very noisy. WARNING: The pump can only run few minutes with air in the fluid without being damaged.
4.2 Bleeding conditions of pump	4.2.1 Follow the instructions "Initial start-up" supplied with the new pump. 4.2.2 Ensure that the pump is completely bled before start-up.	The pump and the inlet line must be completely bled before start-up, otherwise the pump will cavitate and make high noise. WARNING: The pump can only run few minutes with air in the fluid without being damaged.
4.3 Min/max nominal inlet pressure	4.3.1 Ensure that inlet pressure is between 1 and 5 bar. 4.3.2 Check the pump for internal damage.	Too high inlet pressure causes too high pressure inside the pump damaging the pistons and eventually the pump. Inlet pressure below 1 bar causes cavitation and insufficient internal lubrication resulting in wear on internal pump parts. Mount a low-pressure switch before the pump and check its set point/ function. The low-pressure switch will ensure that the pump does not start until the inlet pressure has reached 1 bar.
4.4 Pump reversing	4.4.1 Dismantle pump and check if anything is broken or worn (See "1. No flow", item 1.2 Pump reversing"). WARNING: The pump must not run without water for more than a few seconds. If the pump takes in water from the high- pressure outlet line, it builds up pressure and will eventually be damaged.	If pump rotates in wrong direction, it will take in water from the high-pressure outlet line. Pressure will be built up inside the pump and it will eventually be damaged.
4.5 High rotation speed (RPM)	4.5.1 If electric motor RPM is too high, dismantle pump and check for damage. 4.5.2 If the RPM is within the specified range of the pump data sheet and abnormal noise remains, dismantle pump and check for damage.	Higher RPM than specified in the pump data sheet results in wear of the pistons, i.e. pistons may be damaged. High RPM will also increase pressure pulsations from the pump, and the noise level will increase. If RPM is changed, noise frequency will also change.
4.6 Outlet pressure	4.6.1 If outlet pressure is too low, check set point of outlet pressure valve. 4.6.2 If outlet pressure is lower than mentioned in the pump data sheet, please contact Danfoss A/S RO Solutions Technical Support. 4.6.3 If outlet pressure has exceeded its maximum, check set point of outlet pressure valve. 4.6.4 Check internal parts for wear/damage.	At too low outlet pressure, the pump will create higher pressure pulsations and thus make noise. Too low pressure also causes insufficient internal lubrication and wear on internal parts. Pump may eventually be damaged. Too high outlet pressure may damage the pump.
4.7 Soft start/stop	4.7.1 Check if noise is normal when the pump is running at operation speed. 4.7.2 If noise is abnormal at operation speed, check internal parts (see above).	Noise frequency changes during soft start-up/ stop.

6. Typical signs of wear

6.1 Valve plate

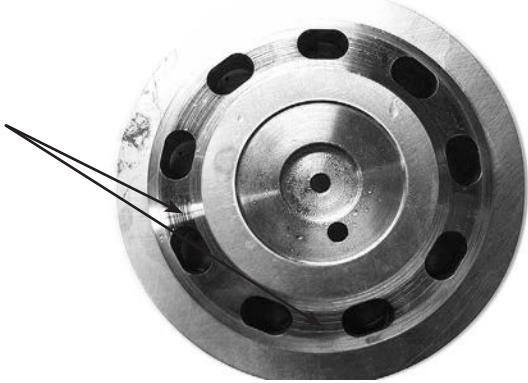
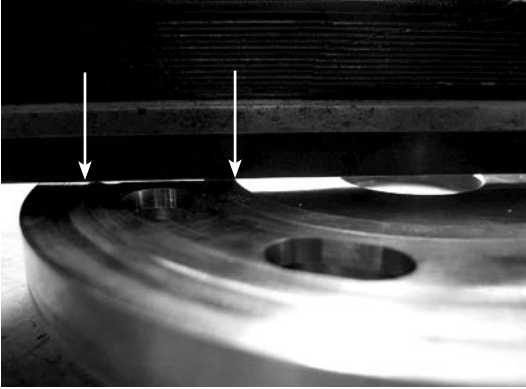
<p>Picture 1</p> 	<p>A normally worn valve plate has no marks/scratches but only a slightly polished surface.</p> <p>No scratches or marks should be felt. The surface must be flat and level.</p>
<p>Picture 2</p> <p>Scratches</p> 	<p>A worn valve plate has scratches, and/or a polished surface. Even small scratches will give a loss of flow.</p>
<p>Picture 3</p> 	<p>A good way to identify a worn valve plate is to hold a straight knife edge over the valve plate. When holding it up to the light, it will be possible to see any space between the knife edge and the valve plate. See picture 3.</p> <p>If any light can be seen between the two arrows on the picture, the valve plate is worn.</p> <p>If any scratches or marks can be felt by running a fingernail over the surface, the valve plate is worn.</p> <p>The valve plate on picture 3 is highly damaged.</p>

6.2 Port plate

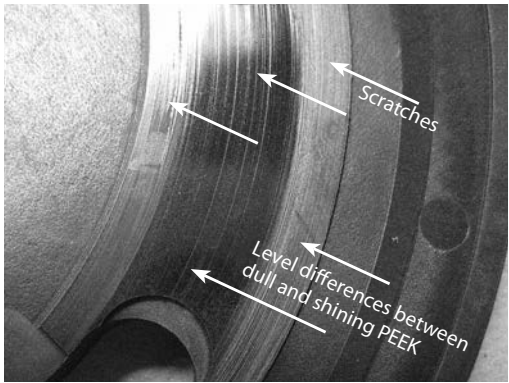
<p>Picture 1</p>  <p>Scratches</p> <p>Level differences between dull and shining PEEK</p>	<p>If the port plate has scratches, level differences or both between the arrows, the port plate must be replaced.</p> <p>Even small scratches or wear will cause loss of flow.</p> <p>To check: See item 6.1, picture 3</p>
--	--

6.3 Swash plate

<p>Picture 1</p> 	<p>If the swash plate is polished 360°, it is an indication of insufficient filtration.</p> <p>The surface of the swash plate must be plane and even at same level all over. To check this, please see item 6.1, picture 3.</p> <p>If the surface has any marks/scratches it is worn/damaged and a new one is required.</p> <p>Please contact Danfoss sales office for further information</p>
---	--

Danfoss A/S
 High Pressure Pumps
 DK-6430 Nordborg
 Denmark

Danfoss can accept no responsibility for possible errors in catalogues, brochures and other printed material. Danfoss reserves the right to alter its products without notice. This also applies to products already on order provided that such alterations can be made without subsequential changes being necessary in specifications already agreed. All trademarks in this material are property of the respective companies. Danfoss and the Danfoss logotype are trademarks of Danfoss A/S. All rights reserved.

Right and wrong

Trouble shooting guide for water hydraulic systems



Design

1. Choice of material

- Rubber
- Plastic
- Stainless steel

Always use system components made of corrosion proof materials

- Iron
- Copper
- Brass
- Aluminium

Non-corrosion proof materials may cause damage

2. Choice of filter

< 10 µm abs.

Install a 10 micron absolute filter with pressure switch

> 10 µm

Return filter with bypass valve and poorer filterability than 10 µm will damage the system

3. Filter location

Locate the return filter in the return line immediately before the tank

Placing the return filter upstream of the final load may damage the pump

4. Pump location

Pump always to be placed below water surface level

Pump location above water surface level will cause damage

5. Suction conditions

System to be dimensioned to provide a suction pressure of the pump inlet of max. 0.1 bar vacuum

Poor suction conditions will cause malfunction and damage the pump

6. Pressure Relief valve

Pressure relief valve to be mounted vertically or with vertical outlet and connected to return hose or tank

Coupling the pressure relief valve outlet directly to the pump inlet may damage the pump

7. Water supply

System to be filled via filter

Filling system with unfiltered water causes damage

Installation

8. Impurities

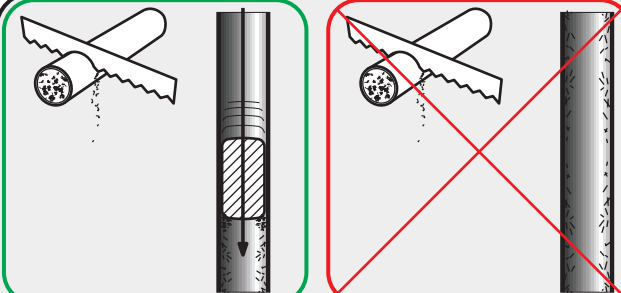

Prior to installation, burrs and chips and other impurities must be removed from pipes and hoses, eg with a felt plug

Chips or other impurities in the system may cause damage

11. Assembly of coupling

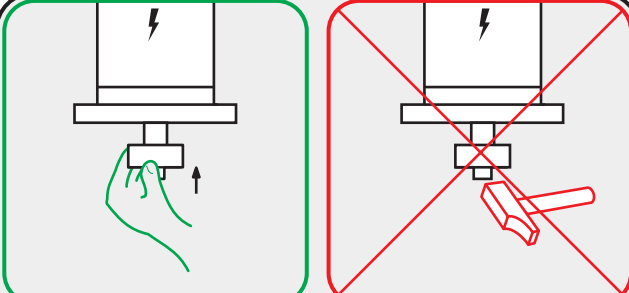

The coupling must be easy and simple to assemble (see product instruction)

Never use force when assembling the coupling parts, as this will damage the motor/pump

9. Sealing

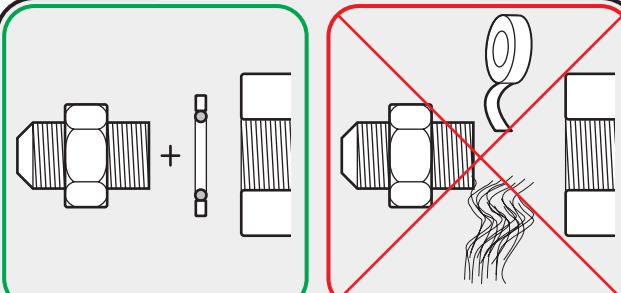

Fittings in screwed components to be sealed with O-rings or bonded seals

Using teflon tape or packing yarn in joints may cause damage

12. Coupling

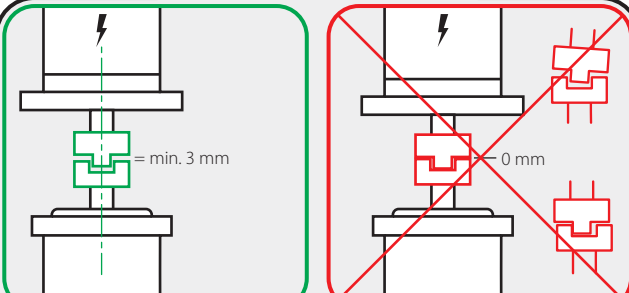

Ensure always to have 3 mm distance between coupling flanges

Insufficient distance and/or misalignment between the coupling flanges will damage the pump

10. Grease

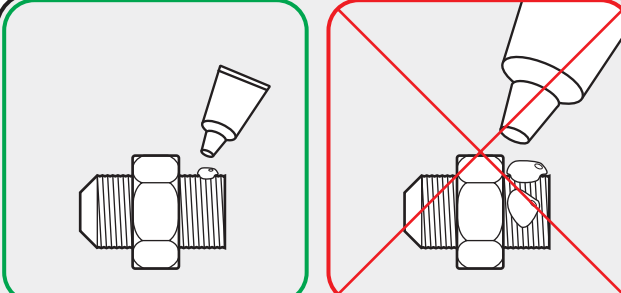

Correctly limited quantities of grease prevent seizing

Too much grease may develop biofilm causing operational failures

13. Water supply

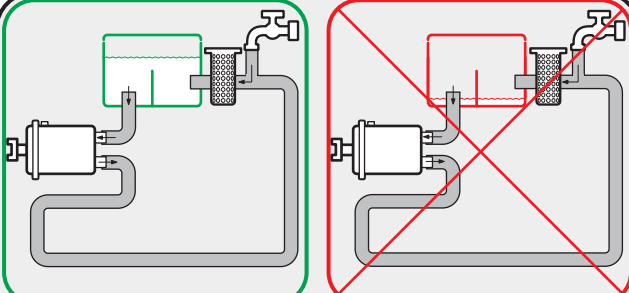

Fill system with water before starting to ensure lubrication and cooling

Starting without water will cause damage

Wiring

14.

Level indicator

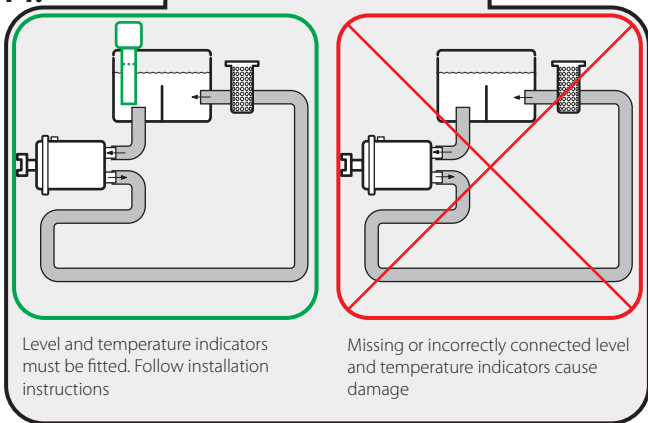

15.

Rotation direction

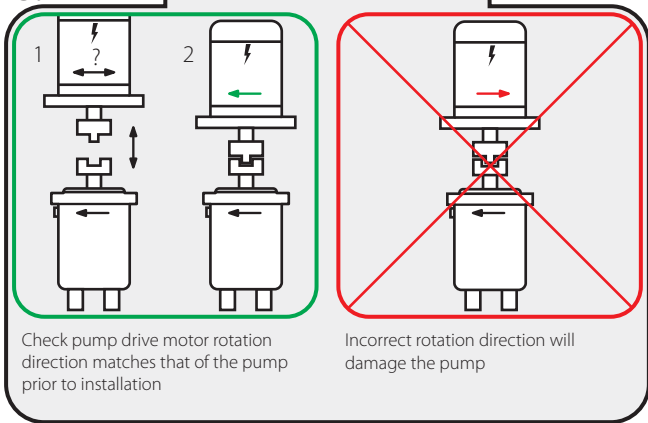

16.

Bleeding

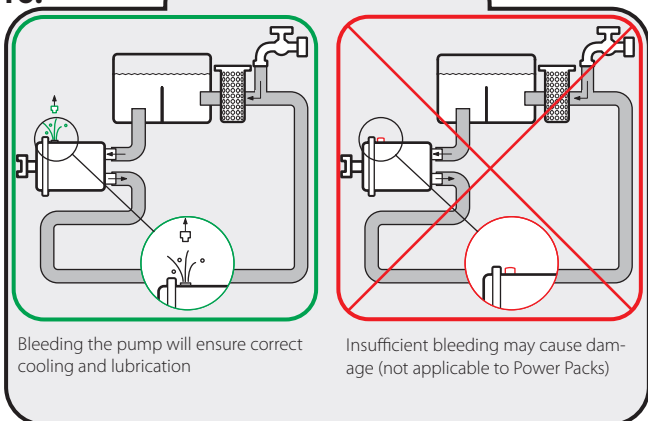

Starting procedure

Cleaning procedure

1. Fill cold water into the system via the return filter and bleed the pump (Power Packs PPH 4 - 6.3 - 10 and 12.5 are self-bleeding)
2. Start and bleed the system -without pressure by opening the bypass valve
3. Add the cleaning agent to give 3% agent/water solution
4. Run the system for 60 min. and activate all components as often as possible to ensure effective flushing with the cleaning agent
5. Empty the system of the cleaning agent solution

Flushing procedure

6. Fill cold water through the return filter and bleed the pump (Power Packs PPH 4 - 6.3 - 10 and 12.5 are self-bleeding)
7. Run the system for 30 min. and activate all components as often as possible
8. Empty the system of the water
9. Alternatively the system may be flushed by running the unit without the return hose while continuously filling up water. The flushing should continue until there is no trace of cleaning agent in the return water
10. Change the return filter element, fill cold water through the return filter and bleed the pump during start up
11. The system is now ready for operation

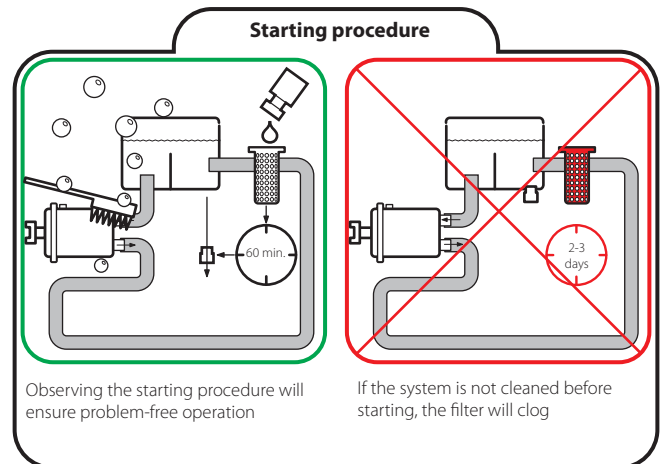

Trouble shooting

Open ended water systems

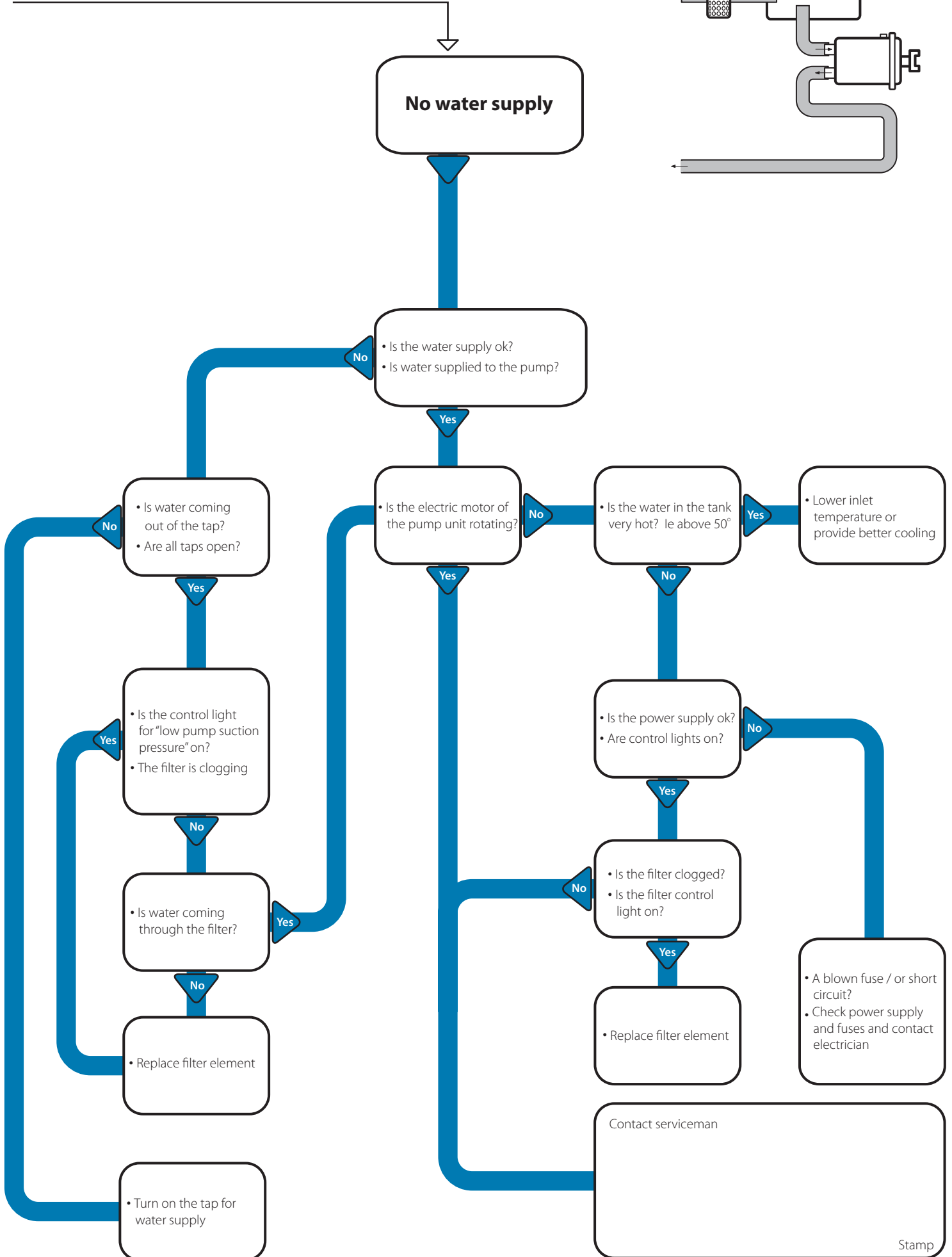
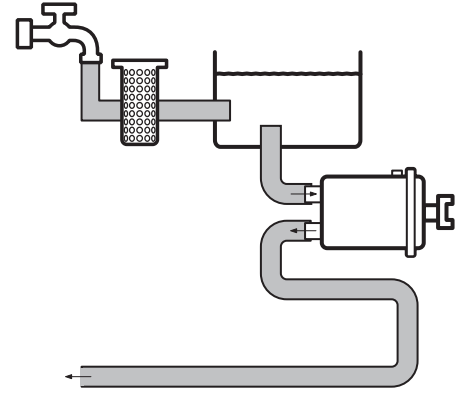

Trouble shooting

Closed water systems

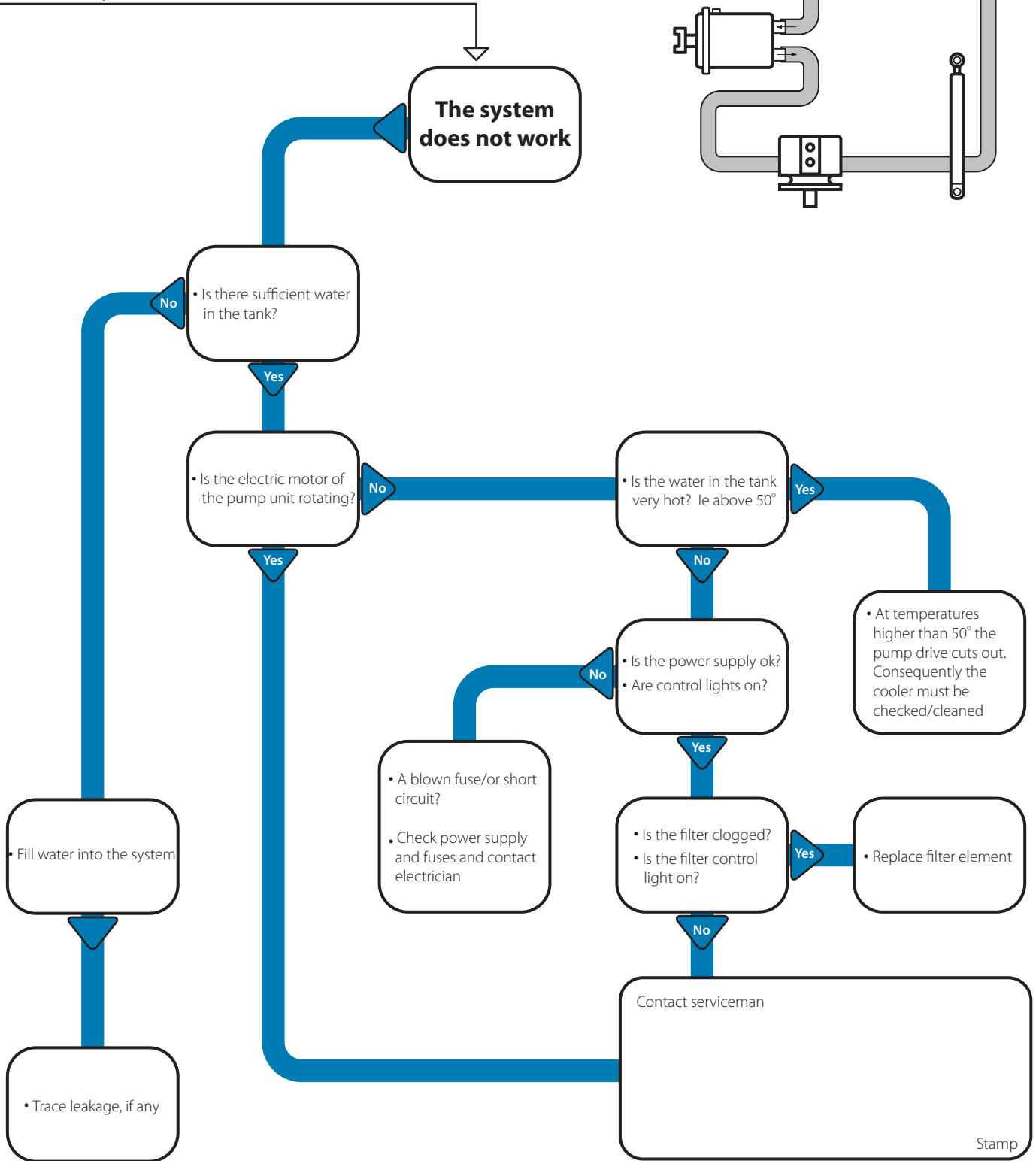
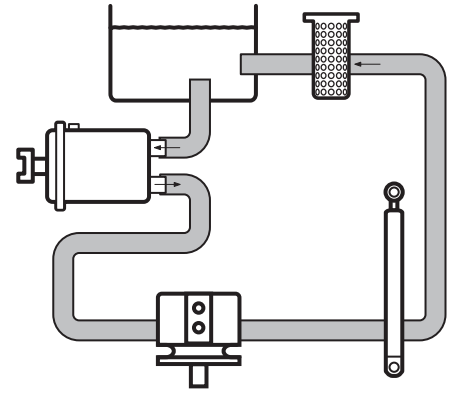

Danfoss can accept no responsibility for possible errors in catalogues, brochures and other printed material. Danfoss reserves the right to alter its products without notice. This also applies to products already on order provided that such alterations can be made without consequential changes being necessary in specifications already agreed. All trademarks in this material are property of the respective companies. Danfoss and the Danfoss logotype are trademarks of Danfoss A/S. All rights reserved.

DK-6430 Nordborg
Denmark

Stamp

Danfoss A/S
High Pressure Pumps
DK-6430 Nordborg
Denmark

Danfoss can accept no responsibility for possible errors in catalogues, brochures and other printed material. Danfoss reserves the right to alter its products without notice. This also applies to products already on order provided that such alterations can be made without subsequential changes being necessary in specifications already agreed. All trademarks in this material are property of the respective companies. Danfoss and the Danfoss logotype are trademarks of Danfoss A/S. All rights reserved.
