

PM180

6-Channel Modbus Pyrometer Hub Operator's Guide



The PM180 is a temperature indicator, data logger, alarm unit and configuration tool for Calex infrared temperature sensors. It is compatible with all models in the PyroBus and PyroMiniBus series, as well as all PyroMini and FibreMini models with Modbus output.

The PM180 functions as the Modbus Master on an RS485 network of up to 6 temperature sensors, and can itself be connected as a slave device to another RS485 network via a second, isolated Modbus interface. This allows multiple PM180 units to be multi-dropped to create a large network of sensors and displays.

Optional alarm relay modules allow the PM180 to be connected to alarm equipment such as sounders and beacons, and optional analogue output modules allow it to be connected to non-Modbus instrumentation.

All the configurable parameters for the hub, the connected sensors and the optional output modules are adjustable via the PM180's built-in resistive touch screen interface, which can be operated even with gloves on.

With an optional MicroSD Card inserted, the PM180 functions as a fully-configurable data logger.

SPECIFICATIONS

Display	2.83" (72 mm) resistive touch TFT, 320 x 240 pixels, backlit	
Supply Voltage	10 to 30 V DC	
Maximum Current Draw	100 mA	
Ambient Temperature Range	0°C to 60°C	
Relative Humidity	Maximum 95%, non-condensing	
Configurable Parameters (global)	Temperature units, date and time, data logging, graph channels, alarm logging	
Configurable Parameters (per channel)	Signal processing, emissivity setting, reflected energy compensation, alarms, Modbus address	
Alarm Configuration	12 alarms (2 per sensor) with adjustable level, individually configurable as HI or LO.	
Temperature Units	°C or °F selectable	
Temperature Resolution	0.1° below 1000°; 1° above 1000°	
Signal Processing	Average, peak hold, valley hold, minimum, maximum	
Display Sample Period	120 ms per device (720 ms in total for 6 devices)	
Compatible Sensor Types	PyroBus (all models), PyroMiniBus (all models), PyroMini (-BB and -BRT models), FibreMini (-BRT models)	
Compatible Output Module Types	ICP DAS M-7061	12-channel relay output module
	ICP DAS M-7061D	As above, with LED indicators
	ICP DAS M-7024	4-channel analogue output module, selectable V/mA

MECHANICAL

Dimensions	98(w) x 64(h) x 36(d) mm excluding cable glands
Weight	280 g

DATA LOGGING

With an optional MicroSD Card installed in the slot inside the PM180, data logging may be manually started and stopped via a button on the temperature display screen, or scheduled to begin at a pre-determined time via the Settings menu.

If the PM180 is connected via the slave interface to another Modbus network, logging may also be started remotely by the Modbus Master on that network.

DATA LOGGING SPECIFICATIONS

Logging Interval	1 to 86,400 seconds (1 day)
MicroSD Card	Max. capacity: 32 GB (not included)
Internal Clock Battery	1 x BR 1225 3V (not included)
Variables Logged	Target temperature, sensing head temperature, alarm events
File Format	.csv (can be imported to Excel)
Configurable Parameters	Sample period, number of samples, scheduled start date and time

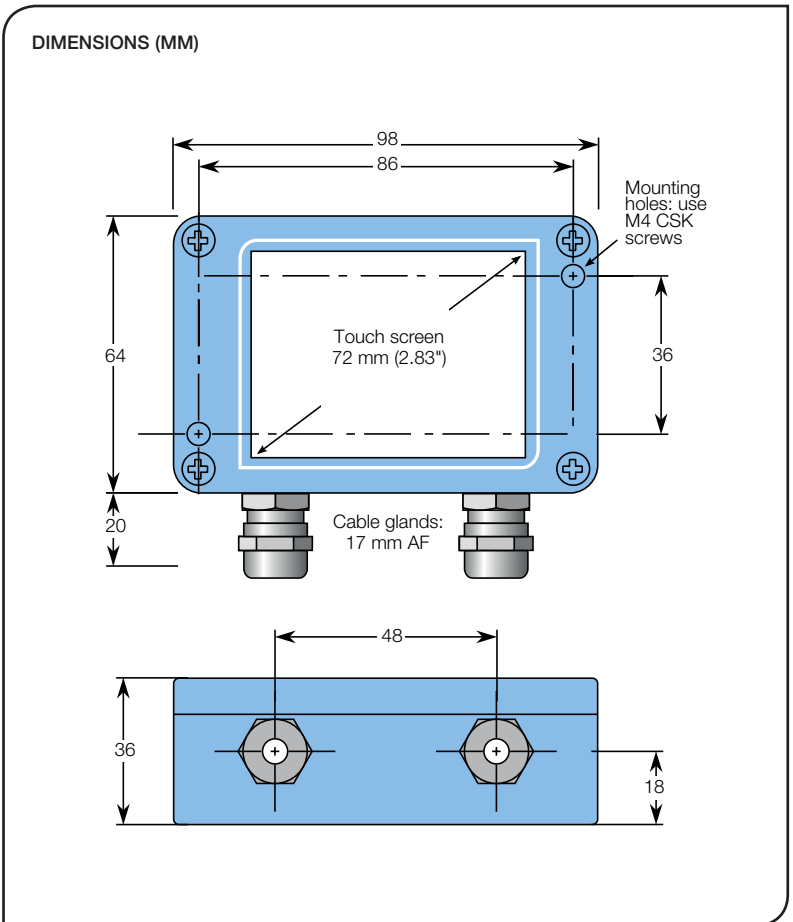

PM180

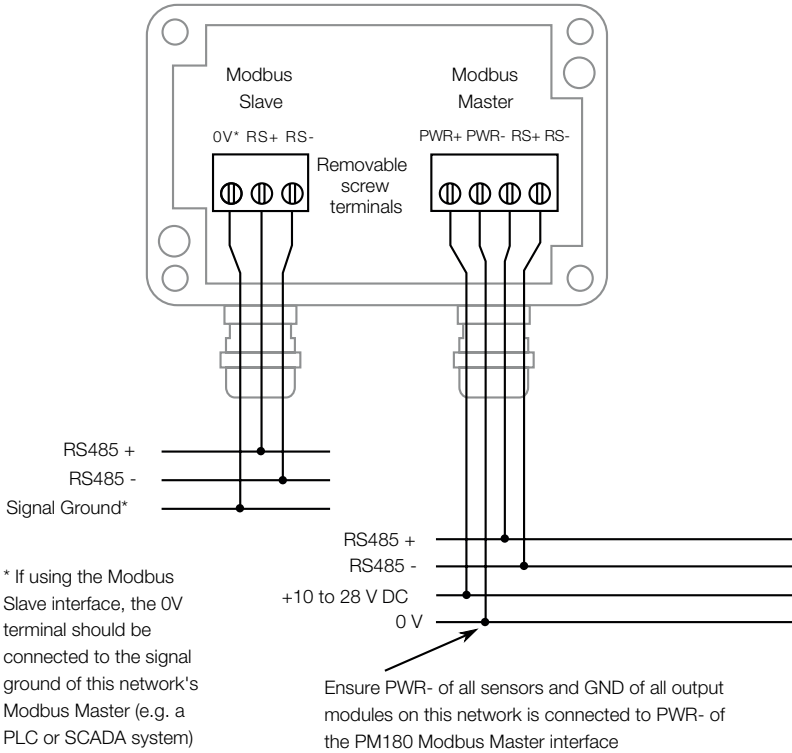

The PM180 has removable screw terminal blocks for the Modbus Slave and Modbus Master interfaces.

- Connect the Master interface to the sensors and output modules. Be sure to check the power supply requirements of each device before applying power.
- Optionally, connect the Slave interface to another Modbus network with its own Modbus Master such as a PLC or SCADA system.

Isolation is provided between the Slave and Master interfaces.

MICROSD CARD AND BATTERY

The MicroSD Card and battery slots are located on the touch screen circuit board. Unscrew the lid of the PM180 to access them.

The battery is optional. With a battery fitted, the internal clock will continue to run when the power is off. Without a battery, the unit will request the date and time each time the power is cycled.

All other settings are stored in the unit's permanent memory and will be preserved when it is switched off, regardless of whether a battery is fitted.

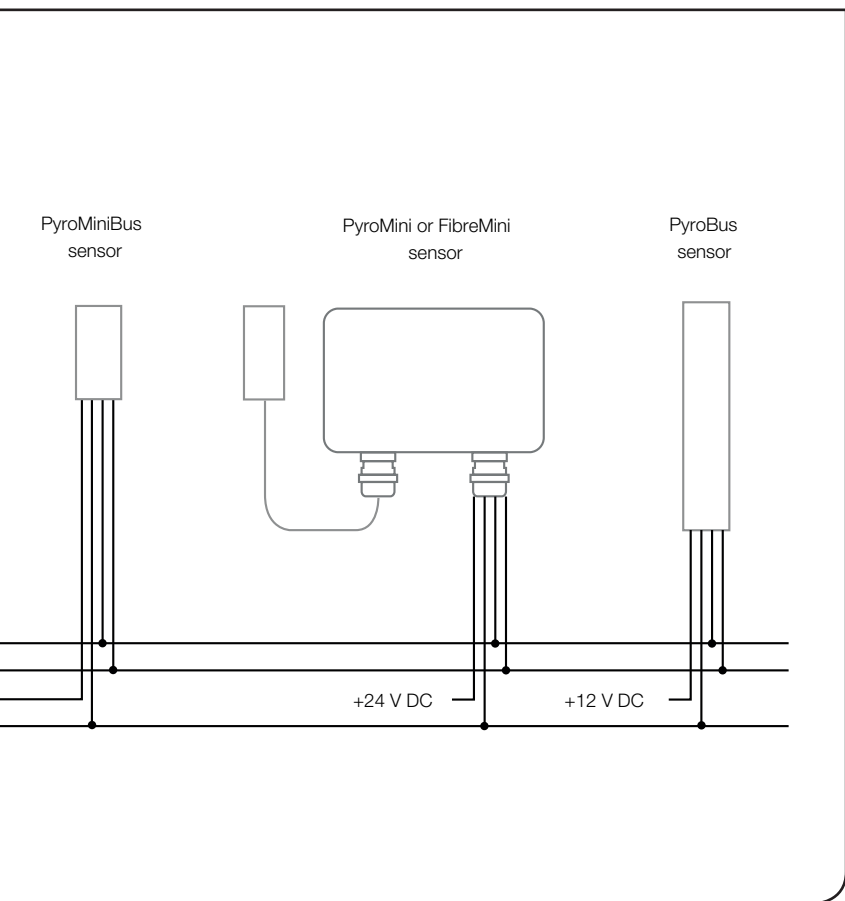

PASSWORD

The default password is 1234. The password may be changed via the touch screen interface.

USING THE TOUCH SCREEN INTERFACE

Visit www.calex.co.uk/PM180 for help on how to use the touch screen interface, including a diagram showing how to navigate to each setting.

MODBUS OVER SERIAL LINE (RS485)

INTERFACE

Baud rate	9600
Format	8 data, No parity, 1 stop bit
Reply delay (ms)	20

SUPPORTED FUNCTIONS

Read register	0x03, 0x04
Write single register	0x06
Write multiple register	0x10

The list below includes all available addresses:

R = Read, W = Write

Address	Length (words)	Description	R/W
0x0000	1	MODBUS slave address	R/W
0x0001	7	Sensor identification string in ASCII	R
		"PM180vx.xx" where x.xx is the firmware version	
0x0008	2	Serial number	R
0x000A	2	Sample Period (1 to 86400)	R/W
0x000C	2	Number of Samples (0 to 86400)	R/W
0x000E	1	Data acquisition enabled (0 for disabled, 1 for enabled)	R/W
0x000F	1	Data acquisition start time: Hours (0 to 23)	R/W
0x0010	1	Data acquisition start time: Minutes (0 to 59)	R/W
0x0011	1	Data acquisition start time: Seconds (0 to 59)	R/W
0x0012	1	Data acquisition start time: Day (1 to 31)	R/W
0x0013	1	Data acquisition start time: Month (1 to 12)	R/W
0x0014	1	Data acquisition start time: Year (2012 to 2105)	R/W
0x0015	1	Alarm log settings	R/W
		Bit 0 - Log trigger time	
		Bit 1 - Log while triggered	
		Bit 2 - Log acknowledge time	
		Bit 3 - Log reset time	
0x0020	1	Remote request - Start logging	R/W
		Write 1 - request start of data logging	
		Read 1 - request pending, Read 0 - no request pending	
0x0021	1	Remote request - Stop logging	R/W
		Write 1 - request termination of data logging	
		Read 1 - request pending, Read 0 - no request pending	
0x0022	1	Remote request - Acknowledge alarms	R/W
		Write 1 - request acknowledgement of alarms	
		Read 1 - request pending, Read 0 - no request pending	
0x0023	1	Remote request - Reset alarms	R/W
		Write 1 - request reset of alarms	
		Read 1 - request pending, Read 0 - no request pending	

SENSOR SETTINGS ADDRESS SPACE

The settings of attached sensors can be read by adding the following offsets to the addresses specified by the sensor manufacturer:

Sensor index	Address offset
0	0x1000
1	0x1100
2	0x1200
3	0x1300
4	0x1400
5	0x1500
6	0x1600

See sensor manual for further details.

Notes:

1. For further information please refer to <http://www.modbus.org/specs.php>
2. Use address 255 to communicate with any connected unit (only one sensor connected)
3. Use address 0 to broadcast to all connected units (no response expected)

GUARANTEE

Calex guarantees each instrument it manufactures to be free from defect in material and workmanship under normal use and service for the period of one year from the date of purchase. This guarantee extends only to the original buyer according to Calex Terms and Conditions of Sale.

Calex Electronics Limited

PO Box 2, Leighton Buzzard, Bedfordshire, England LU7 4AZ

Tel: +44 (0)1525 373178 Fax: +44 (0)1525 851319

Email: mail@calex.co.uk Online: <http://www.calex.co.uk>