

B.29 SHOTBOLT SOLENOID LOCKING POWER OFF WITH POSITION MONITORING IP54

BDC.29PM54 and BAC.29PM54

- Maximum radial force: **800kg**
- Plunger output and input force: **500g**
- Stroke: **30mm**
- Mounting horizontal
- Standard voltage: **24V DC - 230V AC (-10%, +5%)**
- Possible voltages: **12V - 220V DC**
110V - 230V AC (-10%, +5%)
- Power: **32W-100% (Permanent service)**
- Return spring: **Internal**
- Position monitoring with NC safety switch
- According to standards: **EN 60947-5-1**
- AC 15 : 240 / 3A
- DC 13 : 24V / 0.55A (L/R = 75ms)
- Protection rating: **IP54**
- Service operating temperature: **-5°C, +40°C**
- Thermal class: **B**
- Total weight: **2.2Kg**

Example of use: Securing dangerous machines according to standards EN292, EN1088, EN60204-1 and EN60947-5-1

- Locking and interlocking movable guards on hazardous machines.
- Secure zone access.
- Anti-run-back stop on hydraulic freight elevator.
- Security stop on elevator or lift table, levelling stop on freight elevator

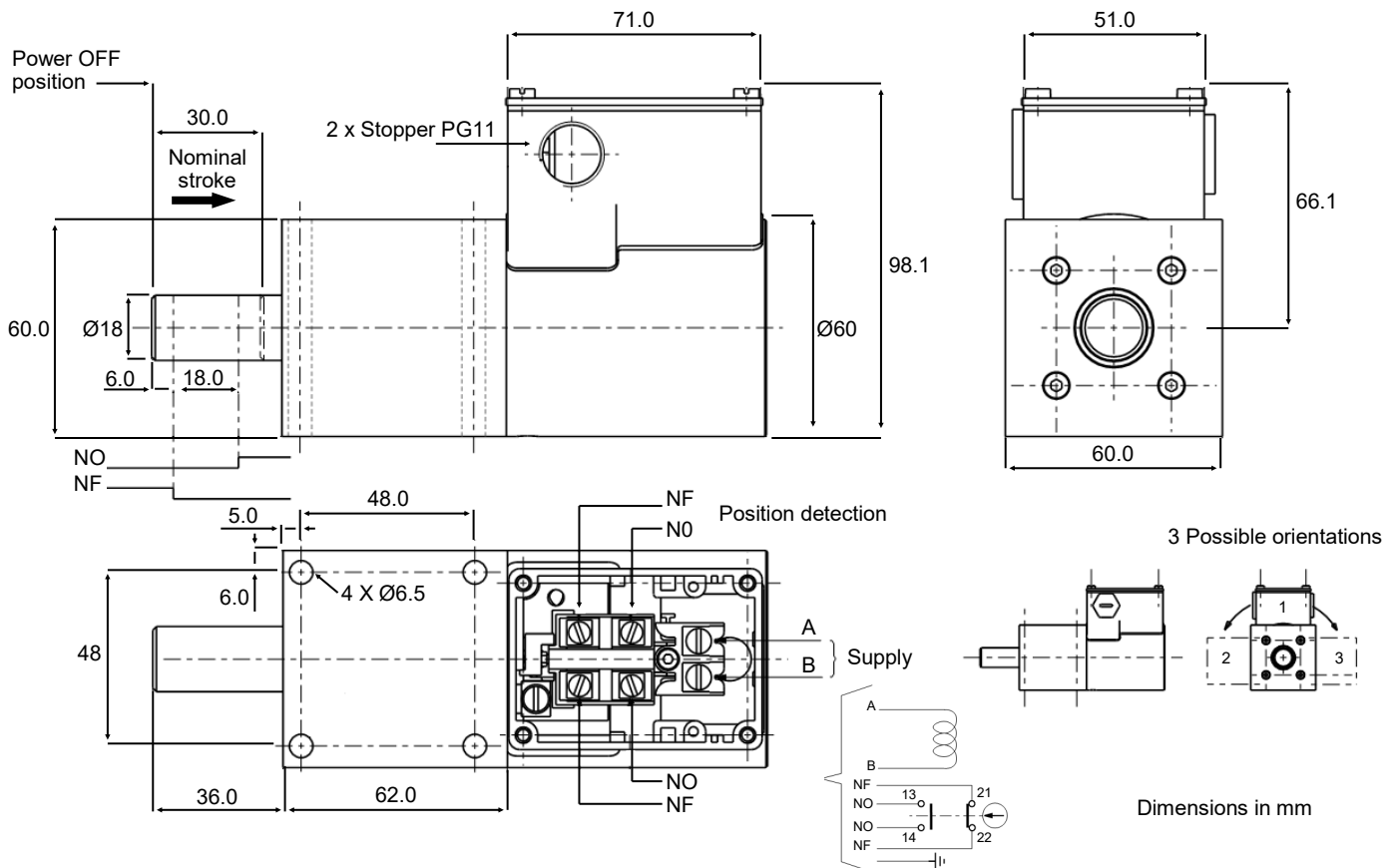

We reserve the right to alter or amend designs without prior notice.

B29PM54 Rev 2 - 2017

HE & BS Benson Ltd

1 Laureate Industrial Estate, Exning Road, Newmarket, Suffolk UK CB8 0AR

T. +44(0)1638 663535 — 663130 F. +44(0)1638 667434 E. sales@hebsenson.co.uk www.hebsenson.co.uk