



Select Headphone Amplifier

User Guide

Check our website for the most recent user guides, firmware, and drivers:
www.msbtechnology.com

Technical support email is:
techsupport@msbtech.com

01.22.2020

Technical specifications

AC Voltage	120/240V (Auto switching) Optional 100V fixed configuration
Dynamic Range	>140 dB
Frequency Response	5Hz-20Khz, ± 0.8 dB
XLR Input	75 Ω Balanced 4Vrms Maximum
Common Mode Rejection Ratio	> 120dB CMRR @ 60Hz > 90dB CMRR @ 1kHz > 70dB CMRR @ 20kHz
Crosstalk	> 90dB Crosstalk @ 1kHz > 65dB Crosstalk @ 20kHz
XLR Output	Direct connection to input when enabled or unit powered off. When listening to headphones, output is muted with 75 Ω output impedance
Headphone Output	2x Stax style outputs
Bias Voltage	580Vdc, 5 M Ω
Power Consumption	80W Less than 2W standby
Chassis Dimensions	Width: 17.5 in (444 mm) Depth: 17.5 in (444 mm) Height without feet: 3 in (79 mm) Stack height: 3.625 in (92 mm) Weight: 36 lbs (16 kg) Product Feet: M6X1 Thread
Shipping Dimensions	Width: 25 in (635 mm) Depth: 25 in (625 mm) Height: 10 in (254 mm) Weight: 61 lbs (28 kg)
Included Accessories	Ground Cable IEC Power Cord 4X Rubber Feet 4X Plastic Foot Inserts

****GENERAL WARNINGS****

Only for use with an MSB DAC.
DO NOT open your headphone Amp.
NO SERVICEABLE PARTS.

Getting Started

When plugging in power, the amplifier detects the input voltage and automatically switches between 120 or 240 volt operation. It is also available in a non-switching 100 volt permanent configuration.

Amplifier Interface

There are two control features just under the front of the powerbase.

Front control	White - Power on. Red - Power off / bypass mode. Amber - Linked mode, 12 volt trigger controlled. Flashing Amber - Over-voltage protection.
'Display' wheel	This is a rolling wheel to control the brightness of the power indication light
Function switch	Normal - The front button on the unit switches between on and off (enables pass through). No IR - The front button on the unit switches between on and off (enables pass through). Remote commands disabled. Linked - The front button on the unit switches between on and pass through while keeping the unit on. Remote commands disabled.

Connecting to your Amplifier

Connect your electrostatic headphones to the front headphone jacks.
Connect your MSB DAC XLR Analog Outputs into the amplifier Inputs
Connect pass through XLR outputs to your main system amplifiers.

User Interface

1	Balanced Analog Input (Right Channel)
2	Balanced Analog Input (Left Channel)
3	Balanced Analog Output (Right Channel)
4	Balanced Analog Output (Left Channel)
5	Power Input 120-240 VAC
6	Grounding Lugs
7	12 Volt Trigger
8	Optimization Module Slot
9	On/Off Button
10	IR Sensor
11	Indicator LED
12	Stax Headphone Outputs (2X)

(Select Headphone Amplifier Jack Panel)

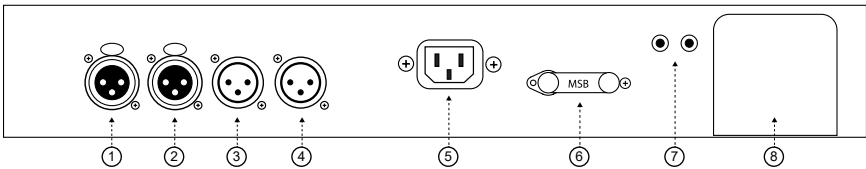

(Select Headphone Amplifier Face Plate)

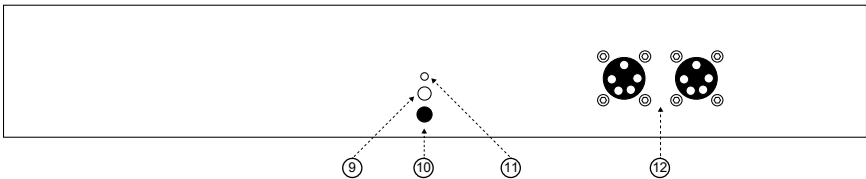

2-Channel System Pass Through Setup

This is the setup that you will follow when implementing your headphone amplifier to be used as a part of a 2-channel system with power amplifiers and loudspeakers.

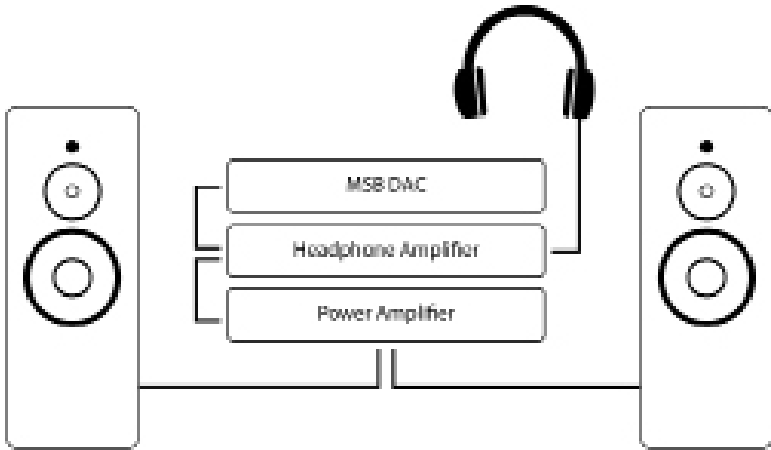

Connect the “Analog Outputs” located on the back of your MSB DAC to the “Analog Inputs” located on the back of your headphone amplifier.

Connect the “Analog Outputs” located on the back of your headphone amplifier to the analog inputs to your power amplifier(s).

Connect your loudspeakers to your power amplifier(s) and connect your headphones to one of the Staxx connections on your headphone amplifier.

When setup in this configuration the “Analog Outputs” act as a direct connection pass through to the “Analog Inputs” whenever the headphone amplifier is switched off or into standby.

When the headphone amplifier is on the “Analog Outputs” that connect to your power amplifier(s) are muted.

When using your headphone in a system configuration like this refer to “For use with 2-channel system” portion of the grounding configuration paper for proper grounding line setup.

Standalone Headphone System Setup

This is the setup that you will follow when implementing your headphone amplifier to be used as the only amplifier in your system.



Connect the “Analog Outputs” located on the back of your MSB DAC to the “Analog Inputs” located on the back of your headphone amplifier.

Connect your headphones to one of the Staxx connections on your headphone amplifier.

When using the headphone amplifier in this configuration like this refer to the “For use as headphone system only” portion of the grounding configuration page for proper grounding line setup.

Ground Jumper - IN - Basic Operation

The Basic Operation does not provide additional isolation. For basic operation be sure the jumper is in place between the Chassis Ground and Amplifier Ground. This is the shipping configuration.

NEVER OPERATE WITHOUT THE JUMPER OR A GROUND WIRE ATTACHED.

Ground Jumper - OUT - Enhanced Operation

The Enhanced Operation provides isolation for both the DAC and the Headphone Amplifier.

For use with 2-channel system:

This setup is for a system that includes headphone and loudspeaker playback.

-Disconnect the DAC powerbase and headphone amplifier grounding bridges.

-Attach a ground wire between the 'Amp Ground' lugs on the powerbase and headphone amplifier.

-Attach a ground wire between one of the 'Amp Ground' lugs and only one loudspeaker amplifier chassis ground. This connection is dependent on the amplifier so you will have to look for the best place to attach the wire to chassis ground.

(Powerbase Connections)

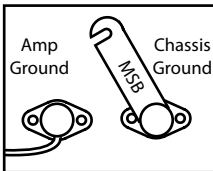

(Headphone Amplifier Connections)

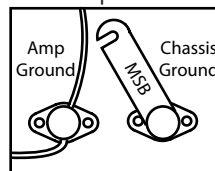

For use as headphone system ONLY:

This setup is for a system that is for headphone playback only.

-Disconnect the DAC powerbase grounding bridge.

-Attach a ground wire between the 'Amp Ground' lugs on the powerbase and headphone amplifier.

-Connect the grounding bridge on the headphone amplifier.

(Powerbase Connections)

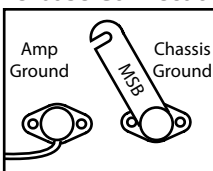

(Headphone Amplifier Connections)

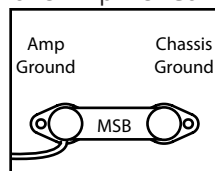

12 Volt Remote Trigger

This powerbase is equipped with a remote trigger for use with other MSB products. The trigger uses a 3 pin mini jack. When any MSB product is turned off, the other products connected will also turn off and vice-versa. This trigger can also be used with other products. Products may use this trigger differently, so you may need to rewire a cable or use an interface relay. The connector is wired as shown. If you connect "signal" to "ground", all MSB products will turn off. If you connect "signal" to "12 V" or leave it open, all MSB products will turn on.

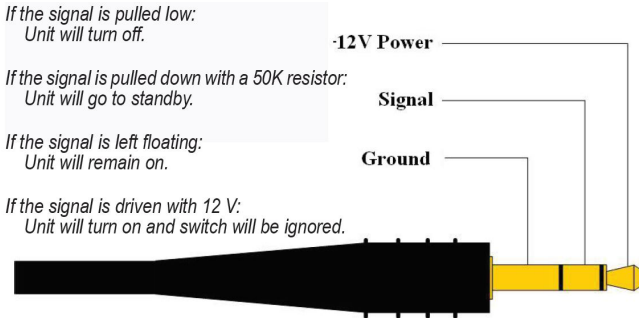

12 Volt Remote Trigger wiring.

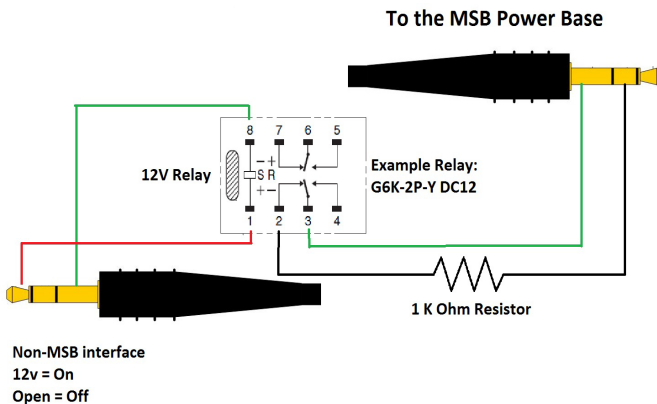

Technical Support

If you are experiencing any issues with your MSB product, please contact your nearest dealer or try our support page at www.msbtechnology.com/support. Please be sure you have the most current edition of your products firmware installed. If your issue persists please feel free to contact MSB directly. Emails are usually responded to in 24 - 48 hours.

Email: techsupport@msbtech.com

MSB Return Procedure (RMA)

If a customer, dealer, or distributor has a problem with an MSB product, they should email tech support before sending anything back to the factory. MSB will do their best to respond within 24 hours. Should it be clear that a product must be returned, tech support should be informed and all the following relevant information should be provided:

1	Product in question
2	Serial number
3	Exact configuration when symptom is observed along with a list with the input used, source material, system connections, and amplifier
4	Customer name
5	Customer shipping address
6	Customer phone number and email
7	Special return shipping instructions

MSB will issue an RMA number and create an invoice with all details outlined except the final price as the product has not yet been seen. This invoice will be emailed so all the above information can be checked and verified by the customer.

The product should be returned with the RMA number present on the box. Work can then begin immediately and the product can be sent back quickly.

Any repair that is difficult and cannot be completed in two weeks will be identified and the customer will be informed when it is to be expected. Otherwise the majority of repairs should be shipped back within two weeks if all the required information is present on the invoice.

Link to page:

<http://www.msbtechnology.com/faq/msb-product-return-procedure/>

The Select Headphone Amplifier Limited Warranty

Warranty includes:

- MSB warrants the unit against defects in materials and workmanship for a period of **10 years** from the date the unit was originally shipped from MSB.
- This warranty covers parts and labor only, it does not cover shipping charges or tax/duty. During the Warranty period, there will normally be no charge for parts or labor.
- During the warranty period, MSB will repair or, at our discretion, replace a faulty product.
- Warranty repairs must be carried out by MSB or our authorized dealer. Please contact your dealer if your unit requires service.

Warranty excludes:

- The Warranty does not cover standard wear and tear.
- The product is misused in any way.
- Any unauthorized modifications or repairs were performed.
- The product is not used in accordance with the Operating Conditions stated below.
- The product is serviced or repaired by someone other than MSB or a authorized dealers.
- The product is operated without a mains earth (or ground) connection.
- The unit is returned inadequately packed.
- MSB reserves the right to apply a service charge if the product returned for warranty repair is found to be operating correctly, or if the product is returned without a returns number (RMA) being issued.

Operating Conditions:

- Ambient temperature range: 32F to 90F, non-condensing.
- The supply voltage must remain within the AC voltage specified on the power base.
- Do not install the unit near heat sources such as radiators, air ducts, power amplifiers or in direct strong sunlight.