

# **I.VA.CO. srl**

## **Installation And Operating Manual**

### **ICV SERIES VACUUM PUMP MODELS 255, 305, 405 & 515**



**www.ivaco.it  
2.2017 (REV1)**

# **INSTALLATION & OPERATING MANUAL**

## **ICV-SERIES CLAW VACUUM PUMPS**

### **ICV 255, 305, 405 & 515**

Please read the manual before operating the vacuum pump.

## **TABLE OF CONTENTS**

### **1.0 INSTALLATION**

- 1.1 General description
- 1.2 Unpacking
- 1.3 Location
- 1.4 Power Requirements
- 1.5 Pressure Connections
- 1.6 Oil Filling on Gear box

### **2.0 SAFETY**

- 2.1 General Notices
- 2.2 Warning Label and explanation
- 2.3 Location of Labels

### **3.0 OPERATION**

- 3.1 Start-up
- 3.2 Stopping the compressor
- 3.3 Ambient operating conditions

### **4.0 MAINTENANCE**

- 4.1 Pump Lube Oil (level / type & quantity / change)
- 4.2 Maintenance Chart

### **5.0 PROBLEM SOLVING**

### **6.0 TECHNICAL DATA**

### **7.0 TYPICAL ICV-SERIES ASSEMBLY DRAWING AND PARTS LIST**

## **INSTALLATION AND OPERATING MANUAL**

This manual is written to cover following contact-less operating claw type compressor. The model number is stamped into the nameplate with serial number: ICV 255, 305, 405 & 515

***Please identify the model number and serial number when ordering parts.***

## 1.0 INSTALLATION

### 1.1 General description

The ICV pump is dry and contactless machines, enclosed in acoustic sound shield and designed to have cooling air passed through the sound shield by fan. The warm air is exhausted through the vent. The ICV is constructed in modular construction consisting of two compartments: pumping and gear chambers separated by using labyrinth seals. In the pump chamber, as two rotary claws rotate in opposite direction, the air sucked in, compressed and discharged under pressure. In the gear chamber (box), two gears for synchronizing of claws rotation will be located with oil lubrication. The pumps are directly driven by a flanged motor via a coupling. Configured with two silencers suitable for compact installation space. The 4" aluminum check valve for anti suck back and inlet filter (flanged) can be installed separately. Ideally suited to use with Frequency Controlled Drives for energy saving.

### 1.2 Unpacking and Storage

Inspect the box and compressor carefully for any signs of damage incurred in transit. Since all compressors are ordinarily shipped F. O. B. from our factory or regional warehouse, such damage is the normal responsibility of the carrier and should be reported to them.

The inlet and exhaust of the compressor are covered with plastic caps to prevent dirt and other foreign substances from entering to it. Leave these caps in place until you are ready to pipe the compressor to your equipment.

The pump should be stored in dry environment with normal air humidity (RH 0~80%, -10C to 60C), not for more than 6 months.

### 1.3 Location

Install the compressor in a horizontal position on a level surface so that it can be evenly supported on its rubber feet. Leave 20 ~ 25 cm of access around the compressor to allow proper cooling. Also, adequate ventilation must be provided for the cooling for the compressor and motor.

Allow access to the oil sight glass in order to inspect the oil level regularly, and the oil fill and oil drain port for easy service.

### 1.4 Power Requirements

A schematic diagram for the electrical motor terminal connections is located in the junction box of the motor or on the motor nameplate. Typical wirings for Three Phase Motors are as below:

## Wiring Scheme- Three Phase Motor

## Low Voltage

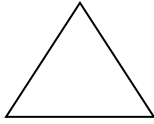

Delta Connection

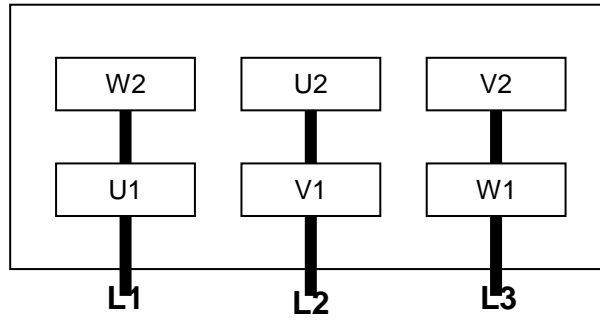

## High Voltage



Star Connection

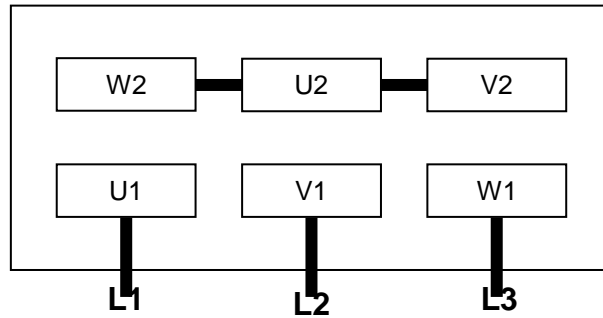

The motor must be connected according to the electrical codes through a fused switch in order to protect the motor against electrical or mechanical overload conditions. The overload of the motor starter must be set at a level equal to the full load motor current listed on the motor nameplate.

If the compressor is supplied with a motor starter, it is preset at the factory according to customer specifications. It is advisable to check that these settings are in line with the voltage at your location. If the voltage is different, please contact I.VA.CO. for motor and starter information.

Correct direction of rotation is marked by an arrow on the motor fan housing and is counterclockwise when looking at the motor from the motor's fan side.

***After electrical connections have been made, the rotation of the motor should be checked. If backward, reverse any two leads of the three at the power connection.***

### 1.5 Vacuum Connections

Use a pipe size that is at least the size of the pump inlet connections. Smaller lines result in a reduced pump capacity.

Pumps operating in parallel on a common main line should have a manual or automatic operated shut-off valve or positive action check valve, installed in the suction line adjacent to the pump suction flange. The built-in anti-suck back valve should not be used as a shut-off valve for the vacuum system.

Remove the plastic protective cap from the inlet port prior to connection of pump to the system.

Should process gas contain dust or other foreign particles, a suitable in line (inlet) filter should be connected to the inlet port. Consult I.VA.CO. for recommendations.

The vacuum piping should be designed to ensure that no liquids such a condensate or liquid carried over from the process can reach the pump. If this possibility exists, a knock-out liquid separator should be installed. Consult I.VA.CO. for recommendations.

The following flange sizes are standard on the pumps

<u>Pump Model</u>	<u>Inlet Size</u>	<u>Exhaust Size</u>
ICV 255 & 305	2"	2"
ICV 405 & 515	DN80 PN10	3"

## 1.6 Oil Filling on Gear Box

The pump is shipped without oil in gear box. After level installation and correct rotation has been established, fill the pump with recommended gear oil through the oil fill port. Oil level should be over 3/4 position on the oil sight glass as shown on the label.



We recommend ISO VG150 gear oil or equivalent oils.

- **Shell OMALA HD 150 or Amsoil GEAR LUBE 150 or ANDEROL # 4150**

The following table gives the approximate quantities of oil required for each model.

<u>Pump Model</u>	<u>Capacity (liter)</u>
ICV 255 & 305	0.90
ICV 405 & 515	1.80

***Do not add fill oil with pump running! Do not overfill.***

## 2.0 SAFETY

Please read the following safety notice carefully before operating the vacuum pump

### 2.1 General Notices

- Understand fully this installation and operating manual before operation.
- The other person except authorized operator should not operate the vacuum pump.
- When the compressor is not properly working, it should be stopped immediately.
- I.VA.CO. shall have no liability for any accident and failure arising from no compliance with instructions in this manual.

### 2.2 Warning labels and its explanation

Following warning labels are shown and attached on ICV series vacuum pump.

#### 2.2.1 Read and Understand a manual:

Read and understand operator's manual before using this machine.

#### 2.2.2 Burn Hazard:

Hot surface. Do not touch.

#### 2.2.3 Loud noise Hazard

Loud noise hazard. Ear protection must be worn.

#### 2.2.4 Hazardous Voltage:

Disconnect power before opening. Contact causes severe electrical shock



### 2.3 Location of the labels

The labels of 2.2.1 Read and Understand a manual, 2.2.2 Burn Hazard, and 2.2.3 Loud noise Hazard shall be shown on the top of sound shield of the pump.

The label of 2.2.4 Hazardous Voltage shall be shown on the cover of motor's terminal box.

## 3.0 OPERATION

### 3.1 Start-up

Check rotation of the motor as described in paragraph 1.4 Power Requirements.

Fill the pump with oil as described in paragraph 1.5 - Oil Filling

Start the pump with the inlet closed. Run the pump for a few minutes and then shut down. Check the oil level again and make sure the oil level is over 3/4 position of oil sight glass as shown on the label.

Add oil though oil fill port, if necessary. Pump oil should only be added when the pump is off

### 3.2 Stopping the pump

To stop the pump, turn off the power. An anti-suck back valve (built-in) for these pumps installed in inlet flange will prevent the air from back flowing into the vacuum chamber after the pump is shutdown.

**Caution: In applications, where the quantity of water vapor is moderate, it is recommended to run the pump for 10 minutes at least with outside air prior to shut down to prevent the vapor from condensing in the pump.**

### 3.3 Operating Conditions

The ICV 1005 is designed to run the ultimate vacuum levels stated in technical data (6.0) for continuous operation. Operation over maximum vacuum level may result in failure of and severe damage to the machine. Vacuum Regulator installed in inlet side is set at maximum allowable vacuum at factory, and a desired vacuum level to below the maximum level can be achieved by rotating the adjustment screw.

The standard version is for use of dry air only, and may not be used in hazardous areas. Handling of humid air or gases containing aggressive chemicals is possible only with specially configures units. Consult I.VA.CO. for assistance.

Excessive back pressure on the unit may result in excessive current draw. Do not operate the vacuum pump over 0.15 kg/cm<sup>2</sup> back pressure

Also it is recommended for operating personnel who is working near the pump to wear ear protectors. If noise below the designed dBA is required, an external sound enclosure can be added to the system, provided adequate ventilation is provided

The ambient and suction air temperature must be between 5 and 40 °C deg

**Caution: Any non compliance may lead to severe injury to persons and damage to the pump.**

**Caution: Maximum number of motor starts per hour should not exceed 10 per hour. Excessive starting of the motor can cause overheating and premature failure of the motor. A minimum run timer should be used with nay panel that may control the pump with automatic starts and stops based on system pressures.**

## 4.0 MAINTENANCE

ICV-Series vacuum pumps require very little maintenance. To ensure optimum performance, the following maintenance steps should be followed:

### 4.1 Gear Box Lube Oil

#### 4.1.1 Oil Level

Check the oil level on monthly basis. Under normal circumstances it should not be necessary to add oil between oil changes. A significant drop in oil level means there is an oil leak. Please check the o-rings, drain plug or oil sight glass.

Check the oil level only when the compressor is shut off. Replenish oil if it drops below bottom position of the sight glass.

**Caution: Do not add oil while the pump is running, since hot oil can escape from the oil fill port.**

#### 4.1.2 Oil Type and Quantity

See section 1.5 - Oil Filling - for details on oil type and quantity

#### 4.1.3 Oil Change

Under normal ambient conditions with proper Gear Oil, it is recommended to change the oil every 10,000 operating hours. It is necessary to make the first oil change between 500 ~1000 operating hours..

**Caution: If different brand oil is being filled, the old oil must be drained completely from the gear box.**

## 4.2 Maintenance Chart

**Weekly:** Check inline inlet filter element / Mesh.

More often if high particulates in inlet stream

**Monthly:** Check the oil level, Protective Mesh.

**Semi-Annually:** Check fans and coupling

**Annually:** Check Bearings / Shaft Seals,

More frequently if operated at ambient temperature exceeding 20°C.

**Every 5,000 operating hours:** Check the gear oil conditions, and if necessary, change the oils.



Inspection hole with G1" plug: Check the coupling and fan through this hole regularly.  
(The endoscope (WireCam) can be used with Smart Phone software)

## 5.0 PROBLEM SOLVING

### 5.1 Problem

The pump does not reach capacity.

### 5.1.1 Possible Cause

Inlet screen (mesh) of the inlet filter clogged with debris.

*Remedy* : check inlet filter element and clean screen (mesh) by compressed air or wash it.

### 5.1.2 Possible Cause

Pipe work is too long or small.

*Remedy* : Use the bigger diameter pipe and shorten the lines length if possible.

## 5.2 Problem

The pump runs over set pressure.

### 5.2.1 Possible Cause

Inlet screen (mesh) in the vacuum regulator clogged with debris.

*Remedy* : clean screen (mesh) and check inlet filter element.

### 5.2.2 Possible Cause

Vacuum regulator set over the set point or is out of order.

*Remedy* : Set the point again or replace it with new one.

## 5.3 Problem

Vacuum pump does not reach the set pressure.

### 5.3.1 Possible Cause

Leak on the pump or system.

*Remedy* : Check the leak on the pump or system.

## 5.4 Problem

The pump runs very noisy.

### 5.4.1 Possible cause

Contamination of the claws or chamber.

*Remedy* : Clean the pumping chamber and the claws.

### 5.4.2 Possible cause

Coupling insert is worn.

*Remedy* : Replace coupling insert in motor/compressor coupling.

### 5.4.3 Possible Cause

Bearing noise

*Remedy* : Replace bearings or call service agent for service or exchange program.

### 5.4.4 Possible Cause

Vacuum regulator noise

*Remedy* : Replace Vacuum regulator

## 5.5 Problem

The pump will not start.

### 5.5.1 Possible Cause

Supply voltage is not proper or is overloaded. Motor starter overload settings are too low or improper; fuses are burned; wire size is too small or too long causing a voltage drop.

*Remedy*: check voltage supply; overload settings in motor starter for size and settings according to motor nameplate. Install proper size wire. If ambient temperature is high, use the next larger size overloads, or adjust settings 5% above motor nameplate value.



Remedy: Repair or replace if needed or call service agent for service or exchange program.

## 5.6 Problem

The pump is running too hot abnormally.

### 5.6.1 Possible Cause

Not enough air ventilation to pump.

Remedy: Make certain a sufficient amount of fresh air is supplied to the pump.

## 5.7 Problem

The pump will not operate (seized up).

### 5.7.1 Possible cause

Rotary Claws, Bearings or Gears stuck on..

Remedy: Call service agent for service or exchange program

## 6.0 TECHNICAL DATA

Specification: Vacuum Application

Model		ICV 255	ICV 305	ICV 405	ICV 515
M3/ Hour	60Hz	300	360	480	600
	50Hz	250	300	400	500
Ulti. Va. Max.	Torr	722.5 Torr gage (50mbar abs )			
Ulti. Va. Conti.	Torr	610			
Kw	60Hz	5,5	6,6	9	11
	50Hz	4,3	5,5	7,5	9
RPM (motor)	60/50Hz	3450 / 2850			
Voltage Available		208~230/460V, 220~240 / 380~420V, 400/690V			
dB(A), Max +- 3 tolerance	60Hz	80	80	78	80
	50Hz	78	78	76	78
Oil Capa (Gear box)	Ltr	0,9		1,8	
Inlet / Outlet Conn.	**BSP(G)	2"		3"	
W x H (mm)		501 x 685	501 x 685	586 x 695	586 x 695
L* (mm)	60Hz	961	975	1105	1291
	50Hz	961	975	1065	1120
Amb. Operating Temp.	(°C)	5°C ~40°C			
Accessories		Non Return Valve, Vacuum Regulator, Exhaust Silencer			

Note: 1) \* Length varies to motor mfg 2) \*\*NPT threads available upon request

# ICV - 255 Dimensions

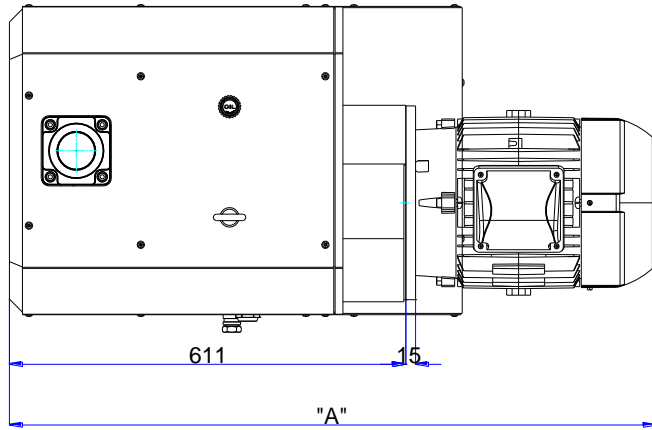

"A"

50Hz, 4.3Kw : 961m m

60Hz, 5.5Kw : 961m m

60Hz, 7.5Hp : 998m m

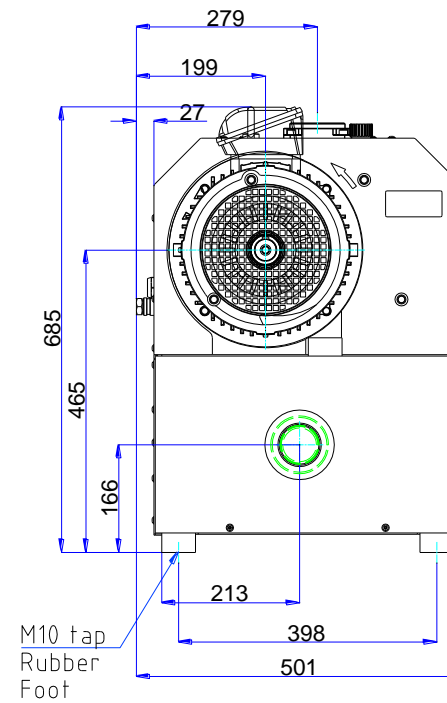
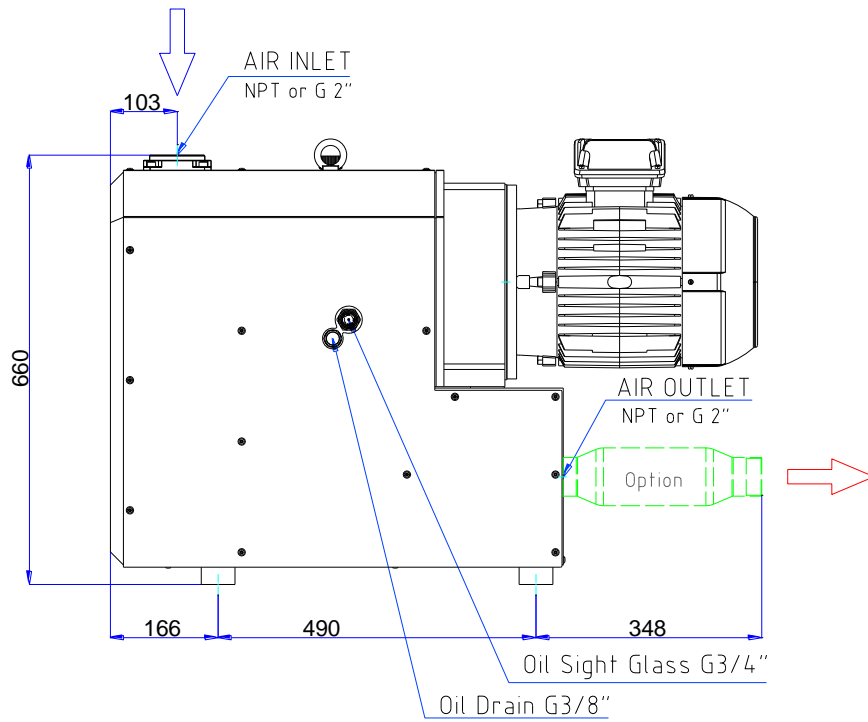

# ICV - 305 Dimensions

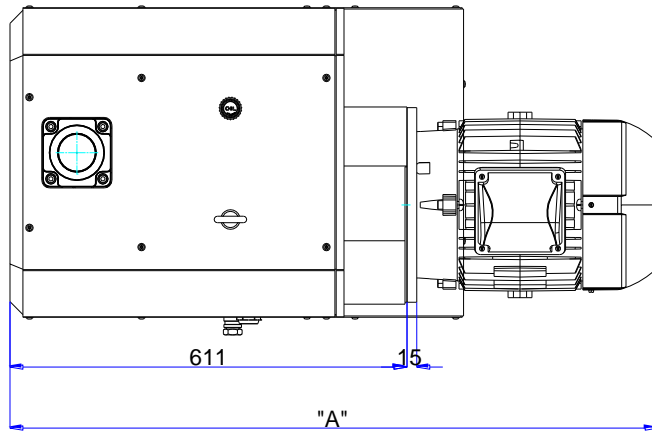

"A"

50Hz, 5.5Kw : 975mm

60Hz, 7.5Kw : 975mm

60Hz, 10Hp : 1,050mm

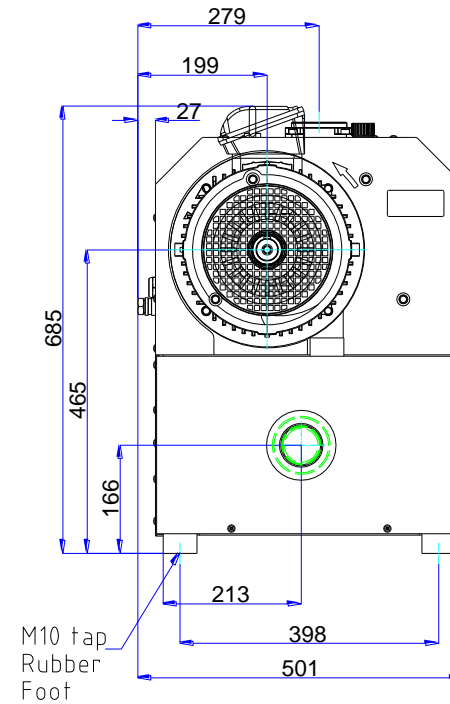
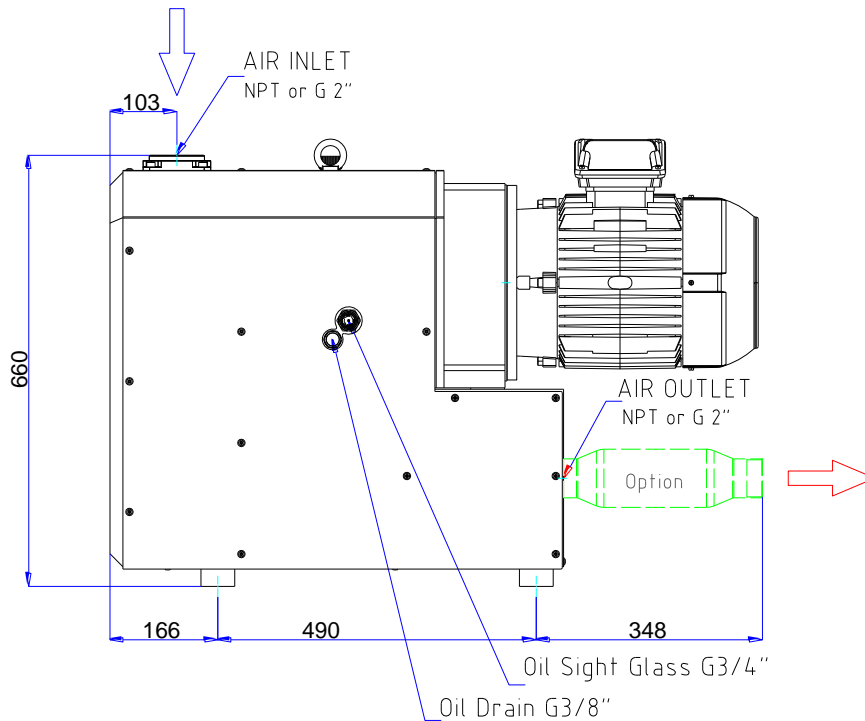

# ASS'y DRAWING VCX-255 / 305 (IEC)

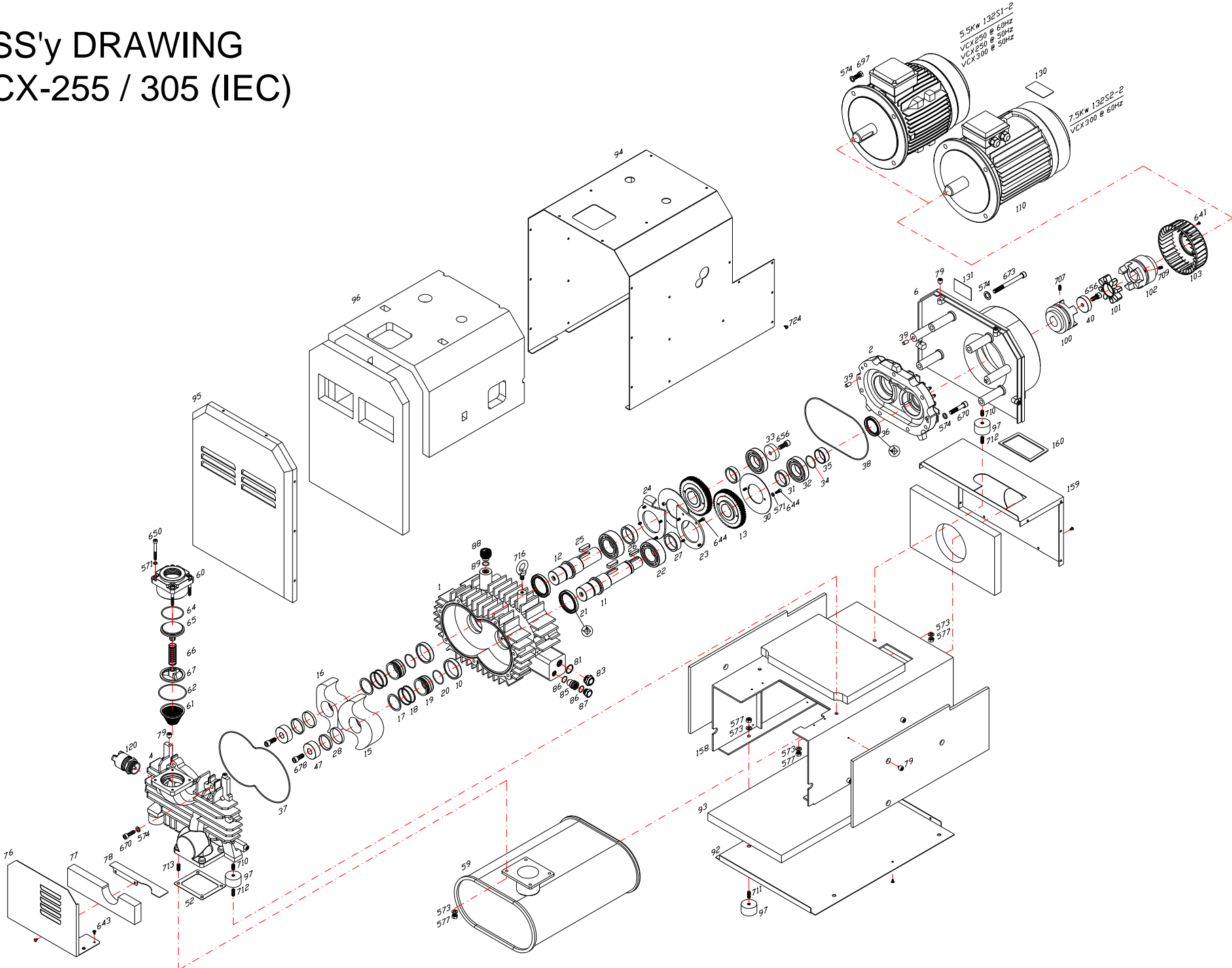

# ASS'y DRAWING VCX-255 / 305 (NEMA)

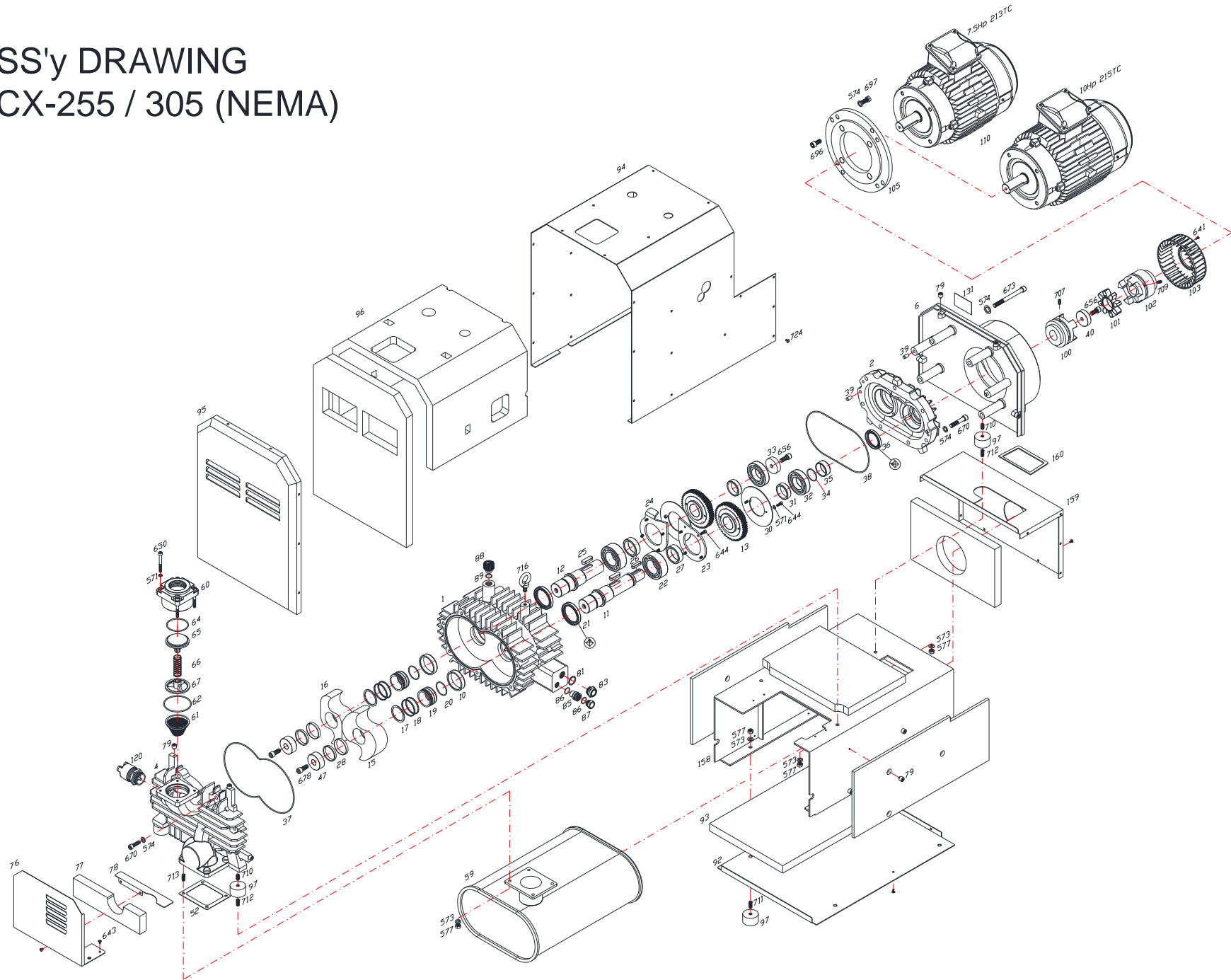

## ICV 255 / 305 PART LIST

POS#	Description	Q'ty	POS#	Description	Q'ty	POS#	Description	Q'ty
1	Gear Box Housing	1	40	Locking Disk	1	105	Flange Adapter (IEC 112M, NEMA 213TC, 215TC)	1
2	Gear Box Cover (rear)	1	47	Locking Disk, side Rotor	2	110	Motor	1
4	Pump Housing Cover 1 (End Plate)	1	52	Gasket, Exhaust Silencer, Steel Silencer	1	120	Vacuum Regulator	1
6	Fan Housing	1	59	Silencer assembly steel	1	130	Label, Direction Arrow	1
10	Sleeve	2	60	Inlet flange, Upper Housing, G 2"	1	131	Name Plate	1
11	Shaft 1	1	61	Inlet screen (Conical )	1	158	Base	1
12	Shaft 2	1	62	O-Ring, Inlet Flange, upper part	1	159	Cover, Exhaust	1
13	Gear 1	2	64	O-Ring, Check valve plate	1	160	Seal	1
15	Rotor 1	1	65	Check valve plate	1	571	Washer, Spring Lock, 6mm	8
16	Rotor 2	1	66	Spring, Check valve	1	573	Washer, Spring Lock, 10mm	11
17	Spacer	2	67	Check valve guide	1	574	Washer, Spring Lock, 12mm	22
18	Piston Ring	4	76	Plate (vertical)	1	577	Hexagon Nut M10	11
19	Sleeve	2	77	Accoustic mat	1	641	Hex. Socket Head Cap Screw / M5 x 15	5
20	O-Ring	2	78	Plate (horizontal)	1	643	Hex. Socket Head Cap Screw / M6 x 10	4
21	Shaft Seal,	2	79	Support isolator	14	644	Hex. Socket Head Cap Screw / M6 x 15	12
22	Bearing,	2	81	Gasket, Oil Sight Glass	1	650	Hex. Socket Head Cap Screw / M6 x 65	4
23	Bearing cover (Plate)	1	83	Oil Sight Glass	1	656	Hex. Socket Head Cap Screw / M12 x 25	2
24	Bearing cover	1	85	Pipe, for Drain Pulg	1	670	Hex. Socket Head Cap Screw / M12 x 50	14
25	Key, for Gear	2	86	O-ring, Drain Plug	2	673	Hex. Socket Head Cap Screw / M12 x 110	4
26	Key, for Coupling	1	87	Drain Plug	1	678	Hex. Socket Head Cap Screw / M12 x 25	2
27	Sleeve	2	88	Oil filler Breather, Plastic	1	695	Hexagon Bolt / M12 x 25 (IEC 112M, NEMA 213TC, 215TC)	4
28	Power Lock (VCX-305)	2 (4)	89	O-Ring for Oil filler	1	696	Hexagon Bolt (NEMA only)	4
30	Flinger	2	92	Shield Cover, Bottom	1	697	Hexagon Bolt / M12 x 35	4
31	Sleeve	2	93	Accoustic Mat for Shield Cover, Bottom	1	707	Set Screw / M8 x 15	2
32	Bearing,	2	94	Shield Cover, Side	1	709	Set Screw / M8 x 10	2
33	Locking Disk	1	95	Shield Cover, Front	1	710	Set Screw / M10 x 15	3
34	O-Ring	1	96	Accoustic Mat for Shield Cover, front and Side	1	711	Set Screw / M10 x 20	4
35	Sleeve	1	97	Foot, Rubber	7	712	Set Screw / M10 x 25	3
36	Shaft Seal,	1	100	Coupling, Pump Side	1	713	Set Screw / M10 x 35	4
37	O-Ring, Compressor cover,	1	101	Insert, Coupling	1	716	Eye Bolt M12	1
38	O-Ring, Gear Box cover,	1	102	Coupling, Motor Side	1	724	Botton Flange Bolt M5x8	44
39	Dowel Pin	4	103	Fan, new, Plastic	1			

### ICV - 405 Dimensions

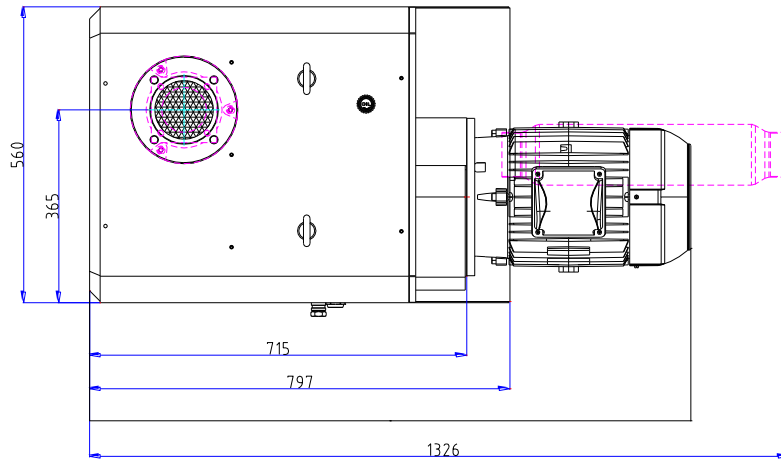

"A"

50H z, 7.5Kw : 1,065m

60H z, 9.2Kw : 1,105m

60H z, 10Hp : 1,242m

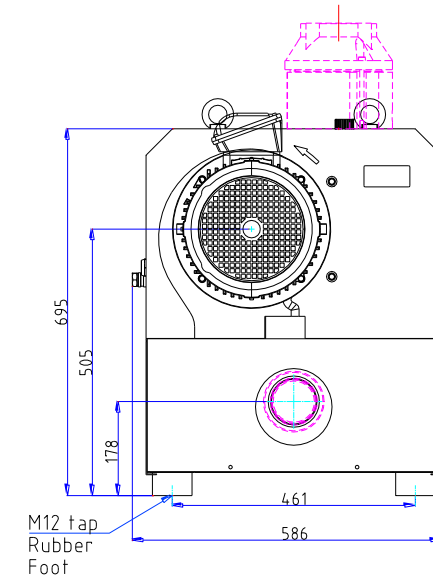
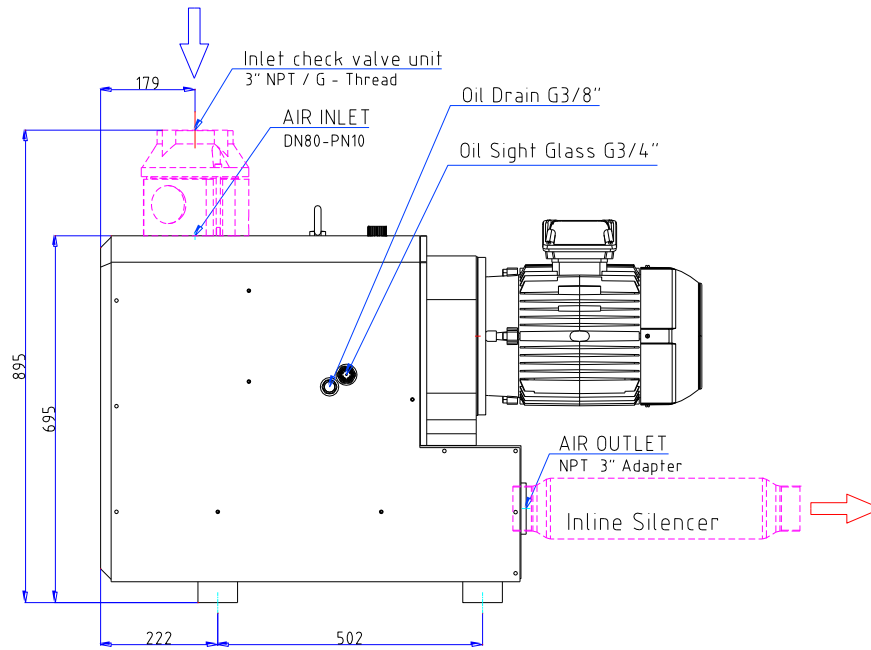

ICV - 515 Dimensions

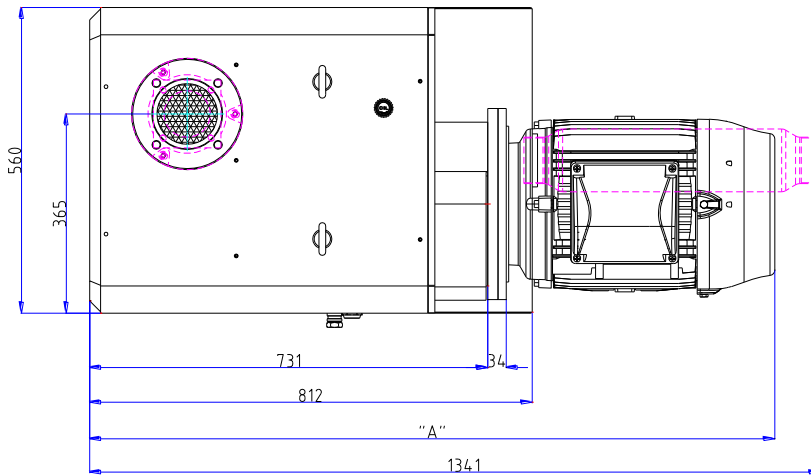

"A"

50Hz, 9.2Kw : 1,120m m

60Hz, 11Kw : 1,291m m

60Hz, 15Hp : 1,257m m

60Hz, 20Hp : 1,302m m

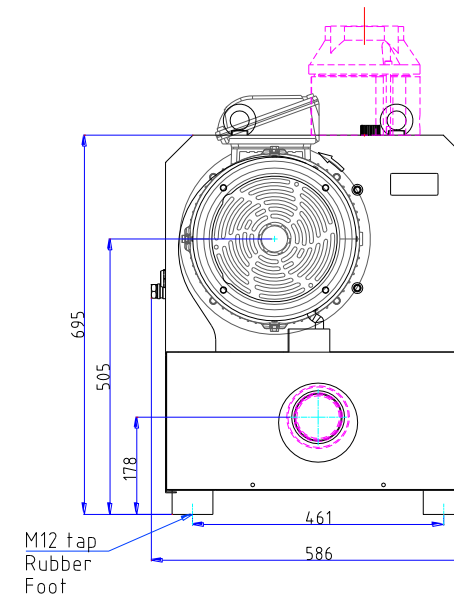
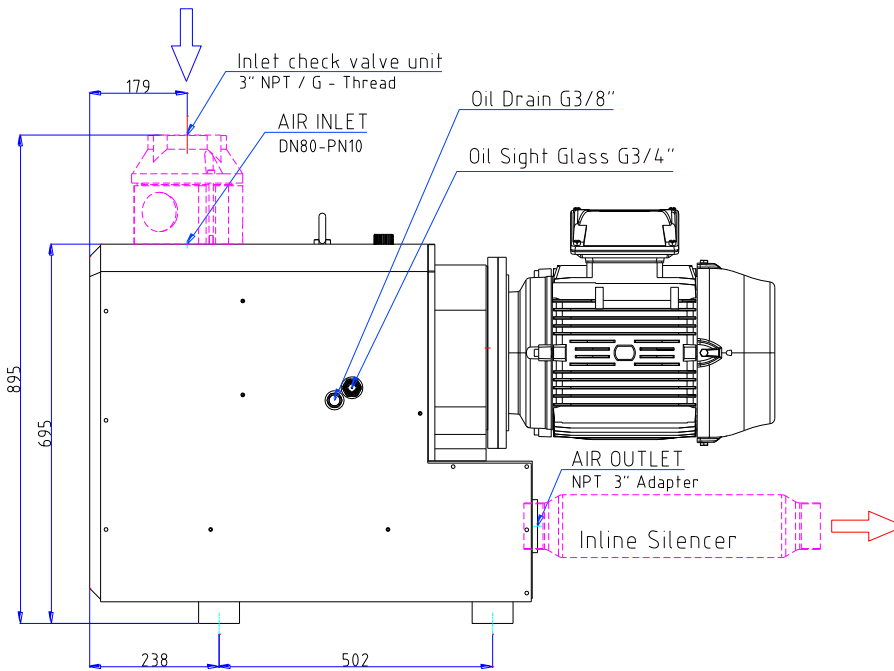



# ASS'y DRAWING VCX-405 / 515 (IEC)

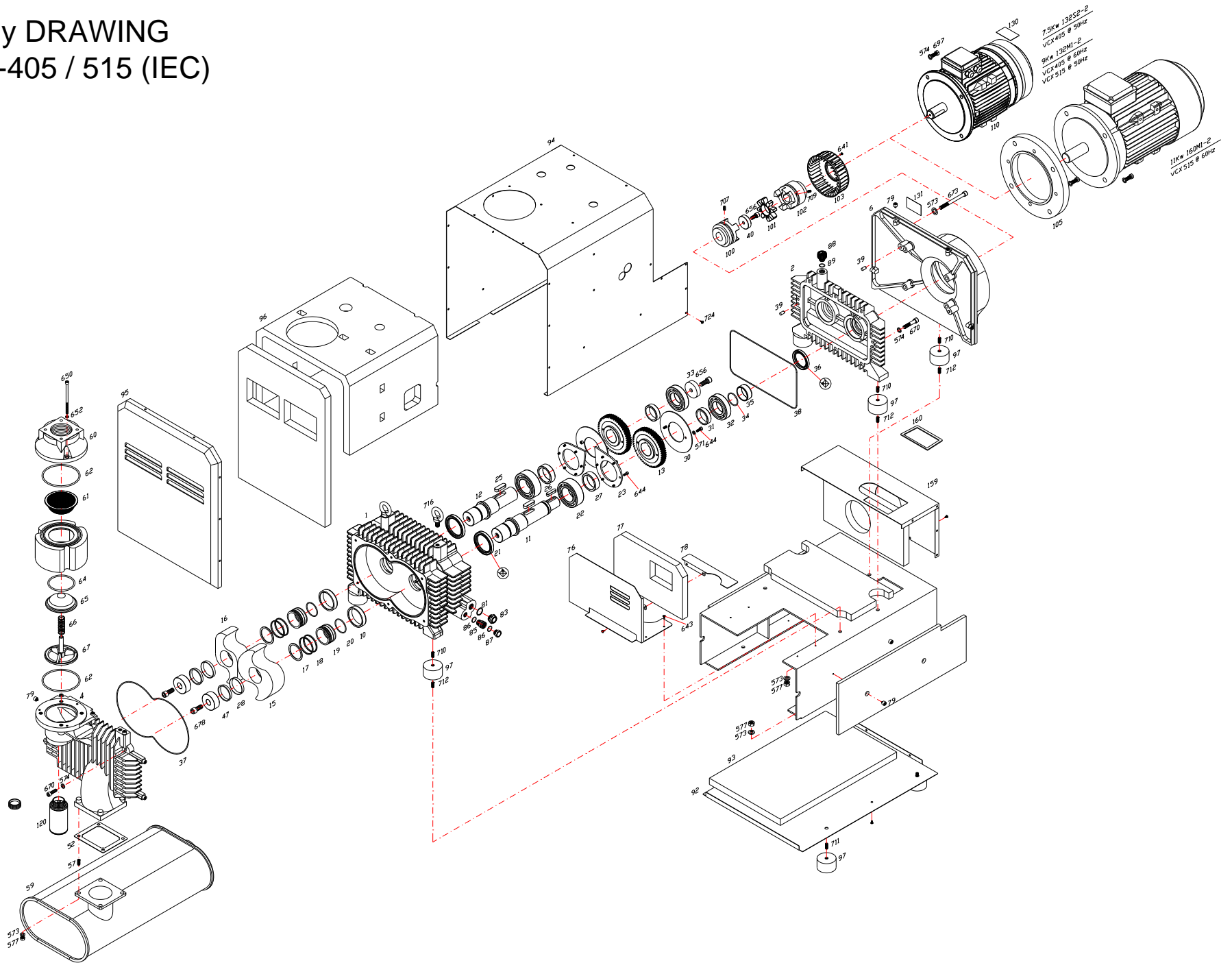



## ICV 405 / 515 PART LIST

POS#	Description	Q'ty	POS#	Description	Q'ty	POS#	Description	Q'ty
1	Gear Box Housing	1	47	Locking Disk, Front	2	105	Flange Adapter	1
2	Gear Box Cover (rear)	1	52	Gasket, Exhaust	1	110	Motor	1
4	Pump Housing Cover (End Plate)	1	57	Stud Bolt	4	120	Vacuum Regulator	1
6	Fan Housing	1	59	Silencer assembly steel	1	130	Label, Direction Arrow	1
10	Sleeve	2	60	Inlet Flang	1	131	Name Plate	1
11	Shaft 1	1	61	Inlet screen (Conical )	1	158	Base	1
12	Shaft 2	1	62	O-Ring, Inlet Flange	2	159	Cover, Exhaust	1
13	Gear	2	64	O-Ring, Check valve plate	1	160	Seal	1
15	Rotor 1	1	65	Check valve plate	1	571	Washer, Spring Lock, 6mm	16
16	Rotor 2	1	66	Spring, Check valve	1	573	Washer, Spring Lock, 12mm	17
17	Spacer	2	67	Check valve guide	1	574	Washer, Spring Lock, 10mm	14
18	Piston Ring	4	76	Plate (vertical)	1	577	Hexagon Nut M12	13
19	Sleeve	2	77	Accoustic mat	1	641	Hex. Socket Head Cap Screw / M5	5
20	O-Ring	2	78	Plate (horizontal)	1	643	Hex. Socket Head Cap Screw / M5	4
21	Shaft Seal	2	79	Support isolator	15	644	Hex. Socket Head Cap Screw / M6	16
22	Bearing,	2	81	Gasket, Oil Sight Glass	1	650	Hex. Socket Head Cap Screw / M8	3
23	Bearing cover	2	83	Oil Sight Glass	1	652	Washer, Spring Lock, 8mm	3
25	Key, for Gear	2	85	Pipe, for Drain Pulg	1	656	Hex. Socket Head Cap Screw / M12	2
26	Key, for Coupling	1	86	O-ring, Drain Plug	2	670	Hex. Socket Head Cap Screw / M10	14
27	Sleeve	2	87	Drain Plug	1	673	Hex. Socket Head Cap Screw / M12	4
28	Power Lock (VCX-515)	2(4)	88	Oil filler Breather, Plastic	1	678	Hex. Socket Head Cap Screw / M16	2
30	Flinger	2	89	O-Ring for Oil filler	1	695	Hexagon Bolt / M12	4
31	Sleeve,	2	92	Shield Cover, Bottom	1	696	Hexagon Bolt (NEMA only)	4
32	Bearing	2	93	Accoustic Mat for Shield Cover, Bottom	1	697	Hexagon Bolt / M12	4
33	Locking Disk	1	94	Shield Cover, Side	1	707	Set Screw / M8	2
34	O-Ring	1	95	Shield Cover, Front	1	709	Set Screw / M8	2
35	Sleeve,	1	96	Accoustic Mat for Shield Cover, front and Side	1	710	Set Screw / M12	5
36	Shaft Seal	1	97	Foot, Rubber	9	711	Set Screw / M12	4
37	O-Ring, Compressor cover,	1	100	Coupling, Pump Side	1	712	Set Screw / M12	5
38	O-Ring, Gear Box cover,	1	101	Insert, Coupling	1	716	Eye Bolt M16	2
39	Dowel Pin	4	102	Coupling, Motor Side	1	724	Botton Flange Bolt M5	37
40	Locking Disk	1	103	Fan, new, Plastic	1			

**I.VA.CO.**

**Italian Vacuum Compressors**

**Via delle Brigole, 33**

**23877 Paderno d'Adda (LC)**

**Italy**

**+39 039 9281084**

**[info@ivaco.it](mailto:info@ivaco.it)**

**[www.ivaco.it](http://www.ivaco.it)**