

SPC

www.spc coils.co.uk

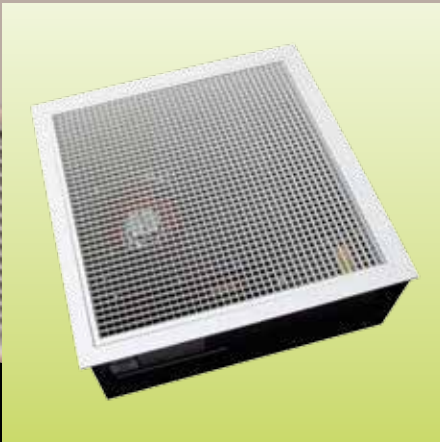

BELGRAVIA *eco*
FAN CONVECTORS
WITH EC MOTORS

▶ ABOUT SPC

THE COMPANY

S & P Coil Products Limited is a UK based specialist manufacturer and supplier of heating and cooling equipment to the public and private sector in the UK.

We have an extensive range of products to meet the needs of our customers including: **Ultraviolet Object & Air Sterilisation, Radiant Panels, Radiant Conditioning Sails, Fan Convectors, Trench Heating, Heating/Cooling Coils and Heat Pipes.**

Our task is straightforward; we improve the comfort of indoor environments for those who live and work in them, whilst ensuring that our expert team is on hand to guide you through the process of specifying and acquiring your bespoke solution. The result is a range of products that are economical to run, robust and aesthetic – with all the sales and technical support that you need.

It's a winning combination, and after more than 30 years in business, we've built a worldwide network of satisfied customers.

KEY FACTS ABOUT SPC

- ▶ Registered provider of approved RIBA and CIBSE accredited CPD's
- ▶ Major supplier to local government and commercial sectors
- ▶ Free self-selection software packages
- ▶ Regional Sales and Technical Support team
- ▶ Free site check / survey
- ▶ ISO 9001 and Investors in people

THE BELGRAVIA FAMILY

- ▶ **Supreme** - aesthetic design and simple installation - **Page 4**
- ▶ **Classic** - proven design with maximum flexibility - **Page 11**
- ▶ **Tilevector** - ceiling mounted unit for incorporating in suspended ceiling - **Page 17**
- ▶ **Chassis** - concealed, down-blow units
- ▶ **Clasp** - concealed unit for cabinet installation
- ▶ **Natural** - convector units without fan assistance

This brochure covers Supreme, Classic and Tilevector units, please contact SPC or visit the website for details of other types.



BELGRAVIA ECO FAN CONVECTORS WITH EC MOTORS

INTRODUCTION



WHY USE A FAN CONVECTOR?

A fan convector puts heat where you need it, when you need it. A fan convector is the quickest and most cost-effective way of bringing a cold room to temperature - whether that room is located in a church, school, library, sports hall, hotel, hospital, leisure centre, shop, office or industrial building.



FAST AND EFFECTIVE

No other heating method brings a room to temperature as quickly as a fan convector. Depending on the size of the room and the number of heaters selected, the room can achieve comfort levels of temperature in a matter of minutes.



HEAT DISTRIBUTION

The fan convector itself may be wall-mounted or ceiling-mounted, but wherever its location, it has an exceptional ability to distribute heat - out from the walls or down from the ceiling depending on location - towards the middle of a room.



UNOBTRUSIVE

A radiator will take up five times the wall space of the equivalent output fan convector. Fan convectors can be easily installed in a single visit and require minimal maintenance with easy and straightforward access when required.



DURABLE

The fan convector is designed to provide years of usage without trouble in a variety of environments. Average life span of a SPC fan convector is 25 years.



EFFICIENT

Fan convectors are the most efficient form of heating for rooms which are used irregularly or intermittently. Heat output is matched to load using simple switched or thermostatic control.



SAFETY CONSCIOUS

To avoid unwanted interference with settings, controls can be located inside the case. For added safety, in the event of accidental contact, the edges of the case can be softly rounded.

If remote switches or thermostats are used, these only switch safe low voltages, not mains.

Units can be supplied to suit low surface temperature applications when required.



CONTROLLABLE

All fan convectors are available with a wide variety of controllers, thermostats and switches.

The new EC motors allow direct control of fan speed via a 0-10V BMS signal.

New to the range of controls is a 2 stage wireless thermostat which is ideal for applications where hard wiring would be unacceptable.



EC MOTORS

S & P Coil Products Ltd now offer EC motors as standard across the range of Belgravia fan convector units. Due to their electronic commutation, EC motors offer significant energy savings compared to conventional AC motor driven fan convectors.

These energy savings occur across the range of rotational speeds and are particularly pronounced at low speeds where the efficiency of conventional AC motors decreases markedly.

Current building regulations specify maximum values for SFP (specific fan power). This is the ratio of the power drawn by the motor in Watts to the airflow generated in l/s and gives an indication of the efficiency of the air moving equipment.

To comply with Part L Building Regulations (2013) fan coil units currently need to demonstrate an SFP figure of less than 0.6 and ensuing revisions to the legislation are likely to significantly reduce this figure.

▶ BELGRAVIA ECO FAN CONVECTORS WITH EC MOTORS
**BELGRAVIA SUPREME -
FAN CONVECTORS**



BELGRAVIA ECO FAN CONVECTORS WITH EC MOTORS

BELGRAVIA SUPREME - FAN CONVECTORS

At the heart of the Belgravia Supreme lies the proven longevity and robust engineering of the Belgravia family of fan convectors. Through a variety of control options, power ratings, and casing configurations, you can adapt the Belgravia Supreme to a wide range of applications.

SPC fan convectors equipped with EC motors are wired in such a way that all the speed control and switching features available on the familiar AC models are available for the new EC motors.

The incorporation of EC technology also allows the use of safe low voltages for remote thermostats and switches. This offers the possibility of replacement of mains switching associated with conventional fan convector motors and controls.

EC motorplates are interchangeable with existing units, offering a refurbishment option for applications where energy saving motors are required.

AESTHETIC

- ▶ attractive two-tone colour scheme - light grey body with dark grey grilles
bespoke colours are available on request
- ▶ softly rounded, slim-line casing with choice of grille profiles
- ▶ unobtrusive - overall dimensions identical for all configurations

VERSATILE

- ▶ suitable for floor, wall, or ceiling mounting
- ▶ split-case design lets you specify inlet and outlet grilles to suit each location
- ▶ available in choice of power outputs and sizes
- ▶ LPHW coil handed prior to delivery to suit your piping arrangement, but can be changed on site if required
- ▶ fan speed control options plus wide range of other factory-fitted control options

TROUBLE-FREE INSTALLATION

- ▶ easy two-stage installation
- ▶ all fixings made directly to lightweight backplate
- ▶ steel-and-aluminium drop-over casing mounted separately - bolts on after completion of installation and commissioning

PRACTICAL LONG-TERM HEATING SOLUTION

- ▶ robust construction requires little maintenance
- ▶ easy servicing and access to all components via tamper-proof front inspection panel
- ▶ split-casing allows replacement of individual casing elements rather than the entire case in the event of severe damage
- ▶ safe pencil-proof grilles and rounded corners

▶ BELGRAVIA ECO FAN CONVECTORS WITH EC MOTORS
**BELGRAVIA SUPREME PLUS -
 FAN CONVECTORS**

The Belgravia Supreme Plus has all the features of the Belgravia Supreme but incorporates a power operated fresh air inlet damper:



CONSTRUCTION

All Belgravia Supreme Plus units are composed of four basic parts:

- (A) **Back Plate Assembly** - including fans, heat exchanger, pipework and electric connections. This also incorporates the fresh air spigot, damper and actuator on the Plus version
- (B) **Plinth** - for floor mounted units
- (C) **Drop-Over Casing** - powder-coated side and front panel in dark grey (RAL 7044), top and bottom castings in light grey (RAL 9002) and pencil proof grilles in light grey (RAL 9002)
- (D) **Access Panel** - powder coated finish in dark grey (RAL 7004) as standard with tamper proof (accessed with an allen key) or lockable (accessed with a key) options

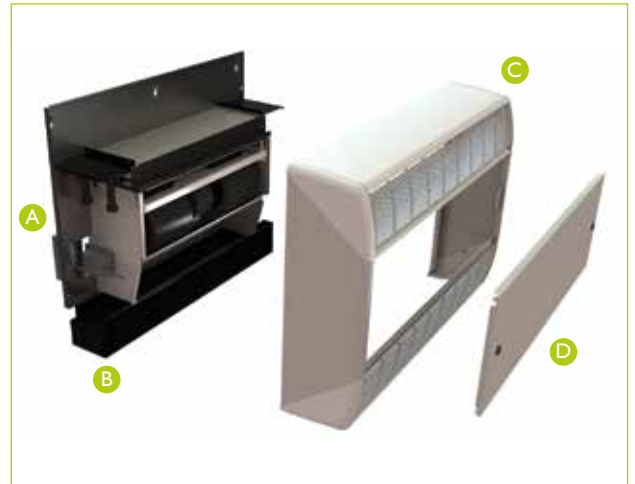

SIZES AND STYLES

Five styles of Belgravia Supreme units are available, each comes in seven models. All styles can have left-hand or right-hand coil connections with top or bottom pipe entry. The styles are shown in the sketches on the folded leaf at the back of this brochure. Maximum dimensions and weight for each model are shown in the table below.

The Belgravia Supreme Plus unit incorporates a power operated fresh air inlet damper. In normal operation the units can circulate and heat room air; if the concentration of pollutants builds up in the space then the FAI damper will open to allow the unit to bring in and temper fresh outside air. The styles available are shown at the back of this brochure.

DIMENSIONS							
MODEL	SPR 30	SPR 40	SPR 60	SPR 75	SPR 90	SPR 115	SPR 150
Length (mm)	800	800	1000	1300	1300	1600	1600
Height (mm)	700 (740mm)*						
Depth (mm)	235						
Maximum Weight (kg)	31	31	41	46	46	52	52

* Plus unit has increased height



BELGRAVIA ECO FAN CONVECTORS WITH EC MOTORS

BELGRAVIA SUPREME - FAN CONVECTORS



PERFORMANCE DATA

PERFORMANCE DATA																
Fan Setting		High					Medium					Low				
Performance		Air Flow Rate l/s	Output kW	Exit Air Temp C	Pressure Drop kPa	Water Flow Rate l/s	Air Flow Rate l/s	Output kW	Exit Air Temp C	Pressure Drop kPa	Water Flow Rate l/s	Air Flow Rate l/s	Output kW	Exit Air Temp C	Pressure Drop kPa	Water Flow Rate l/s
Model	SPR 30	155	5.1	42	0.6	0.11	124	4.5	45	0.5	0.10	99	3.9	48	0.4	0.09
	SPR 40	140	6.2	53	0.9	0.14	112	5.3	56	0.7	0.12	89	4.6	58	0.5	0.10
	SPR 60	236	9.4	48	2.5	0.23	172	7.8	52	1.8	0.19	105	5.6	59	1.0	0.14
	SPR 75	280	10.0	44	3.3	0.24	189	7.9	49	2.2	0.19	110	5.5	56	1.2	0.14
	SPR 90	317	12.3	47	4.8	0.30	231	10.2	51	3.5	0.25	120	6.5	60	1.6	0.16
	SPR 115	248	14.1	62	7.2	0.34	188	11.5	65	5.0	0.28	128	8.4	69	3.0	0.21
	SPR 150	329	17.2	58	10.2	0.42	289	15.7	60	8.8	0.38	180	11.1	66	4.8	0.27

Based on 80/70°C water and 15°C entering air

CORRECTION FACTORS													
Mean Water Temperature °C		80			70			60			50		
Water Temperature Drop °C		5	10	20	5	10	20	5	10	20	5	10	20
Entering Air Temperature °C	-5	1.46	1.40	1.36	1.27	1.24	1.15	1.11	1.05	0.98	0.92	0.86	0.75
	0	1.38	1.36	1.27	1.20	1.17	1.08	1.02	0.96	0.88	0.83	0.79	0.63
	5	1.30	1.26	1.19	1.12	1.08	1.00	0.93	0.88	0.79	0.75	0.70	0.52
	10	1.23	1.18	1.11	1.02	1.00	0.92	0.85	0.81	0.69	0.67	0.61	-
	15	1.14	1.08	1.02	0.94	0.90	0.82	0.76	0.73	0.58	0.57	0.51	-
	20	1.05	1.00	0.94	0.87	0.82	0.73	0.67	0.63	0.46	0.49	0.42	-
	25	0.96	0.93	0.86	0.77	0.73	0.63	0.58	0.55	-	-	-	-

* Factors are approximate. SPC can provide more accurate data if required

NOISE DATA

PERFORMANCE DATA				
Fan Setting	Boost	Medium	Low	
Model	SPR 30	46	39	33
	SPR 40	45	38	32
	SPR 60	46	41	35
	SPR 75	44	38	33
	SPR 90	43	37	32
	SPR 115	42	39	34
	SPR 150	45	44	39

NOTES:

1. NR levels are based on a room volume that would normally be heated by a single unit of each size shown
2. Reverberation time of the room is taken to be 0.4 seconds
3. The listener is assumed to be standing in the middle of the room
4. The unit is assumed to be wall mounted

FAN ASSEMBLY ELECTRICAL DATA

230V / 50 HZ SUPPLY										
Fan Setting		High			Medium			Low		
Performance		Airflow (l/s)	EC power draw (W)	EC SPF (W/l/s)	Airflow (l/s)	EC power draw (W)	EC SPF (W/l/s)	Airflow (l/s)	EC power draw (W)	EC SPF (W/l/s)
Model	SPR 30	155	34	0.22	124	20	0.16	99	13	0.13
	SPR 40	140	27	0.19	112	16	0.14	89	11	0.12
	SPR 60	223	84	0.38	184	53	0.29	108	15	0.14
	SPR 75	280	53	0.19	189	23	0.12	110	19	0.17
	SPR 90	317	73	0.23	231	34	0.15	120	18	0.15
	SPR 115	248	40	0.16	188	23	0.12	128	18	0.14
	SPR 150	329	80	0.24	289	58	0.20	180	22	0.12

BELGRAVIA ECO FAN CONVECTORS WITH EC MOTORS

BELGRAVIA SUPREME - FAN CONVECTORS



CONTROLS AND ACCESSORIES

A range of optional accessories are available for Belgravia Supreme units, the most popular are shown below.

FACTORY FITTED ACCESSORIES		
	Reference	Function
Thermostat	LTC	Low water temperature fan cutout
	ALTC	Adjustable low water temperature fan cutout
	T1	In-built on-off control
	T2	In-built change speed control
	T1 - T2	Combined on-off/change speed control
	RT1	Remote mounted on-off control
	RT2	Remote mounted change speed control
	TLX1	Tamper-proof on-off stat
	TLX2	Tamper-proof change speed stat
	WIRELESS	Wireless 2 Stage thermostat
Switches	RS1	On-off rocker switch
	RS2	Summer-winter switch
	RS3	Three speed rocker switch
	RS12	Combined on-off / summer-winter rocker (built in/remote)
	RS13	Combined on-off / change speed rocker (built in/remote)
	RS23	Combined summer-winter / change speed rocker (built in/remote)
	RS123	Combined on-off, summer-winter & change speed rocker (built in/remote)
BMS	BMS1	Relay for remote enable/disable signal
	BMS2	Direct control of fan speed via 0-10V BMS signal
Electrical Connections	FSB	Fuse spur box
	CCB	Customer connection box
Case Options & Accessories	EAV	Extended air vent
	AL	Low hydraulic resistance heat exchanger
	RAF	Reversed airflow
	AF3	Air filter
	SPF	Special Paint Finish
	P	Plinth
	LAP	Lockable access panel
	TAP	Tamper proof access panel
	BOX1F	Metal flush mounting box for single rocker switch
	BOX1S	White plastic surface mounting box for single rocker switch
	BOX2F	Metal flush mounting box for combined rockers switches
	BOX2S	White plastic surface mounting box for combined rocker switches
	INVCS	Inverted casing



BELGRAVIA ECO FAN CONVECTORS WITH EC MOTORS

BELGRAVIA SUPREME - FAN CONVECTORS



STANDARD ENGINEERING SPECIFICATION

The Belgravia Supreme fan convector shall be manufactured by S & P Coil Products Limited, SPC House, Evington Valley Road, Leicester. The heater shall be suitable for the duties as described in the literature, dependent on the model selected. The quantities and model references shall be indicated in the schedule, the constructional features complying with the under-mentioned specification.

Case	The case shall be manufactured from aluminium extrusions and end-castings, with medium gauge mild steel front and side panels. The detachable access panel shall be fully trayed, and be retained by two tamper-proof fasteners. The internal chassis shall be constructed from medium gauge mild steel. The casing will locate into angled slots on the internal chassis and will be locked in place with standard bolts.
Finish	The case and internal chassis components shall be degreased and treated with an approved priming process, followed by final coats of colour-specified powder-coat finish.
Grilles	Integral grilles to be of linear pattern complying with BSEN 60335, manufactured from extruded aluminium with treated finish.
Attachable Plinth	Plinth, where called for, shall be manufactured from medium gauge mild steel, treated and paint-finished to suit.
Filters	Filters shall be a washable-type Bondina P15/150 non-woven polyamide, or equivalent, bonded with synthetic resin, and rated at EU2 arrestance complying with BSEN 779. Filters should be removable for cleaning.
Heat Exchangers	The heat exchanger shall be of fin block construction, comprising aluminium fins mechanically bonded to copper primary tubes brazed, in turn, into copper headers having BSP female flow and return connections at the same end, and rated in accordance with BS 5141. 1/8" BSP air bleed and drain connections to be provided as standard.
Test Pressure	The heat exchanger shall be tested to 22 bar (2,200kPa) air under water.
Working Pressure	All heat exchangers to be suitable for a maximum working pressure of 10 bar (1,000 kPa).
Motor Plate, Fan & Motor Assembly	The motor plate assembly shall be readily withdrawable for ease of maintenance, being resiliently mounted on guide rails. Ceiling mounted units shall have motor plates fixed by Nylock retaining nuts.
Fans	The fans shall be of the double inlet, double width centrifugal type, with forward curved blades. They shall be dynamically balanced and directly mounted onto the motor shaft. Single or double fans shall be used according to unit size.
Motors	The motor(s) shall be electronically commutated external rotor type with an in-built electronics enclosure. The motor shall incorporate maintenance free ball bearings. Motors shall be IP44 and insulation class B rated. Rotational speed shall be controlled via a 0-10V signal to the terminal block of the motor.
Damper Actuator	230V, open/close actuator with a 5Nm torque rating. Power consumption 1.5W
Wiring & Controls	Provision shall be made for internal wiring with selected control options, and an internally mounted customer connection box shall be provided for interfacing remote options to the unit. All internal wiring shall be tri-rated heat-resistant cable. Unit motors to be suitable for operation with a standard single phase 230V/50Hz supply.
Packaging	Each fan convector shall be despatched in a purpose-made carton, which will be clearly marked with the unit model reference, and instructions called for in the schedule.
CE Marking	The fan convector shall comply with all relevant EU directives currently in force.

BELGRAVIA ECO FAN CONVECTORS WITH EC MOTORS

BELGRAVIA SUPREME - FAN CONVECTORS

SPECIAL APPLICATIONS

The performance data shown on the previous page is applicable to conventional boiler temperatures and flow rates. While such systems are still regularly used, it is increasingly common for fan convectors to be installed in systems which take advantage of low water flow rates to enhance efficiency and provide reduced return water temperature.

SPC manufacture their own coil heat exchangers and are able to offer the Supreme unit with a special 'low flow' coil to suit the above scenario. This special heat exchanger prevents the rapid fall off of capacity with flow rate. The table below shows data at a typical set of conditions, please contact SPC for performance against other criteria.

PERFORMANCE DATA

PERFORMANCE DATA																
Fan Setting		High					Medium					Low				
Performance		Air Flow Rate l/s	Output kW	Exit Air Temp C	Pressure Drop kPa	Water Flow Rate l/s	Air Flow Rate l/s	Output kW	Exit Air Temp C	Pressure Drop kPa	Water Flow Rate l/s	Air Flow Rate l/s	Output kW	Exit Air Temp C	Pressure Drop kPa	Water Flow Rate l/s
Model	SPR 40	140	3.3	34	0.5	0.03	112	2.7	35	0.4	0.03	89	1.0	25	0.1	0.01
	SPR 60	236	6.7	38	2.1	0.07	172	5.5	41	1.5	0.05	105	3.8	45	0.8	0.04
	SPR 75	280	9.3	42	4.6	0.09	189	7.3	47	2.9	0.07	110	4.9	52	1.5	0.05
	SPR 90	317	10.1	41	5.2	0.10	231	8.3	45	3.7	0.08	120	5.3	51	1.7	0.05
	SPR 115	248	9.9	48	5.9	0.10	188	8.2	51	4.3	0.08	128	6.2	55	2.6	0.06
	SPR 150	329	12.0	45	8.2	0.12	289	11.0	46	7.1	0.11	180	8.0	51	4.0	0.08

Based on 70/45°C water and 15°C entering air

LOW SURFACE TEMPERATURE UNITS

As a result of SPC's ability to manufacture bespoke heat exchangers, units can be supplied to suit low surface temperature applications as required, for example in nurseries. SPC will design suitable heat exchangers based on the hot water system being used to prevent the fan convector casework exceeding the LST threshold.



BELGRAVIA ECO FAN CONVECTORS WITH EC MOTORS

BELGRAVIA CLASSIC - FAN CONVECTORS



EC MOTORS



CONTROLLABLE

BELGRAVIA CLASSIC - FAN CONVECTORS

▶ BELGRAVIA ECO FAN CONVECTORS WITH EC MOTORS

BELGRAVIA CLASSIC - FAN CONVECTORS

Short lead times and a long pedigree make the Classic the specifier's first choice fan convector.

- ▶ **FULLY-TESTED IN DEMANDING LOCATIONS**
30 years' use and experience, the Classic has proved its strength and reliability, time after time.
- ▶ **WIDE RANGE OF HEAT OUTPUTS**
The Classic comes in seven output models: from 3kW to 15kW on the medium speed setting.
- ▶ **UNRIVALLED CHOICE OF CASE STYLES**
The versatile Classic comes with a choice of more than 30 case styles and installation options (wall, ceiling, or concealed).
- ▶ **FACTORY-FITTED OPTIONS CUSTOMISE EACH FAN CONVECTOR**
The Classic comes with a range of more than 70 factory-fitted options that convert each heater into a customised heating solution.
- ▶ **QUIET AND UNOBTRUSIVE**
The clean lines and quiet running of the Classic are ideal for sensitive locations. The standard case colours are grey (with black grilles) or beige (with brown grilles), but cases can be matched to any decor.
- ▶ **EASY TO INSTALL**
You can install the Belgravia Classic in a single visit. Each unit is fully-tested before despatch and, within the case, there's ample room for pipework connections.
- ▶ **ENERGY-EFFICIENT, MONEY-SAVING CONTROLS**
A range of thermostatic controls and switches are available on all classic units. The tailored solution will provide control of the space temperature in an energy-efficient manner. Options are available for direct BMS control and wireless communication.



BELGRAVIA ECO FAN CONVECTORS WITH EC MOTORS

BELGRAVIA CLASSIC - FAN CONVECTORS



SIZES & STYLES

The sizes/weights and available styles are shown in the rear of the catalogue.



PERFORMANCE DATA

PERFORMANCE DATA																
Fan Setting		Boost					Medium					Low				
Performance		Air Flow Rate l/s	Output kW	Exit Air Temp C	Pressure Drop kPa	Water Flow Rate l/s	Air Flow Rate l/s	Output kW	Exit Air Temp C	Pressure Drop kPa	Water Flow Rate l/s	Air Flow Rate l/s	Output kW	Exit Air Temp C	Pressure Drop kPa	Water Flow Rate l/s
Model	BEL 30	155	3.9	36.0	0.5	0.09	124	3.5	38.5	0.4	0.08	99	2.9	39.4	0.3	0.07
	BEL 40	140	5.8	49.5	1.1	0.14	112	5.0	52.2	0.8	0.12	89	4.2	54.3	0.6	0.10
	BEL 60	236	9.3	47.8	3.0	0.22	172	7.3	50.4	1.9	0.17	105	5.2	56.3	1.0	0.12
	BEL 75	280	11.6	49.5	5.3	0.28	189	8.5	52.5	2.9	0.20	110	5.9	59.7	1.7	0.14
	BEL 90	317	13.0	49.2	6.3	0.31	231	10.3	52.2	4.3	0.25	120	6.8	62.2	1.9	0.16
	BEL 115	248	13.5	60.4	7.7	0.32	188	10.8	62.9	5.3	0.26	128	8.1	67.7	3.0	0.19
	BEL 150	329	15.9	55.3	10.4	0.38	289	14.6	57.1	9.0	0.35	180	10.7	64.5	4.9	0.25

Based on 80/90°C water and 15°C entering air

CORRECTION FACTORS													
Mean Water Temperature °C		80			70			60			50		
Water Temperature Drop °C		5	10	20	5	10	20	5	10	20	5	10	20
Entering Air Temperature °C	-5	1.46	1.40	1.36	1.27	1.24	1.15	1.11	1.05	0.98	0.92	0.86	0.75
	0	1.38	1.36	1.27	1.20	1.17	1.08	1.02	0.96	0.88	0.83	0.79	0.63
	5	1.30	1.26	1.19	1.12	1.08	1.00	0.93	0.88	0.79	0.75	0.70	0.52
	10	1.23	1.18	1.11	1.02	1.00	0.92	0.85	0.81	0.69	0.67	0.61	-
	15	1.14	1.08	1.02	0.94	0.90	0.82	0.76	0.73	0.58	0.57	0.51	-
	20	1.05	1.00	0.94	0.87	0.82	0.73	0.67	0.63	0.46	0.49	0.42	-
	25	0.96	0.93	0.86	0.77	0.73	0.63	0.58	0.55	-	-	-	-

* Factors are approximate. SPC can provide more accurate data if required

NOISE DATA

PERFORMANCE DATA				
Fan Setting		Boost	Medium	Low
Model	BEL 30	46	39	33
	BEL 40	45	38	32
	BEL 60	46	41	35
	BEL 75	44	38	33
	BEL 90	43	37	32
	BEL 115	42	39	34
	BEL 150	45	44	39

NOTES:

1. NR levels are based on a room volume that would normally be heated by a single unit of each size shown
2. Reverberation time of the room is taken to be 0.4 seconds
3. The listener is assumed to be standing in the middle of the room
4. The unit is assumed to be wall mounted

FAN ASSEMBLY ELECTRICAL DATA

230V / 50 HZ SUPPLY										
Fan Setting		High			Medium			Low		
Performance		Airflow (l/s)	EC power draw (W)	EC SPF (W/l/s)	Airflow (l/s)	EC power draw (W)	EC SPF (W/l/s)	Airflow (l/s)	EC power draw (W)	EC SPF (W/l/s)
Model	BEL 30	155	34	0.22	124	20	0.16	99	13	0.13
	BEL 40	140	27	0.19	112	16	0.14	89	11	0.12
	BEL 60	223	84	0.38	184	53	0.29	108	15	0.14
	BEL 75	280	53	0.19	189	23	0.12	110	19	0.17
	BEL 90	317	73	0.23	231	34	0.15	120	18	0.15
	BEL 115	248	40	0.16	188	23	0.12	128	18	0.14
	BEL 150	329	80	0.24	289	58	0.20	180	22	0.12

BELGRAVIA ECO FAN CONVECTORS WITH EC MOTORS

BELGRAVIA CLASSIC - FAN CONVECTORS

SPECIAL APPLICATIONS

The units are designed to operate against conventional hot water boiler temperatures and flow rates but variations are available should these not be standard.

Many modern heating systems are designed at lower hot water temperatures in order to increase the efficiency of the boiler. As the hot water temperature reduces then the output from the fan convector will drop unless a larger heat exchanger is used. In this instance the 'enhanced' option (see table below) should be used.

PERFORMANCE DATA																
Fan Setting		Boost					Medium					Low				
Performance		Air Flow Rate l/s	Output kW	Exit Air Temp C	Pressure Drop kPa	Water Flow Rate l/s	Air Flow Rate l/s	Output kW	Exit Air Temp C	Pressure Drop kPa	Water Flow Rate l/s	Air Flow Rate l/s	Output kW	Exit Air Temp C	Pressure Drop kPa	Water Flow Rate l/s
Model	BEL 40	126	3.0	34	0.2	0.05	101	1.3	26	0.1	0.02	80	1.2	28	0.1	0.02
	BEL 60	212	6.3	39	1.0	0.10	155	5.0	41	0.7	0.08	95	3.2	43	0.3	0.05
	BEL 75	252	7.2	38	1.6	0.12	170	5.5	41	0.9	0.10	99	3.5	45	0.5	0.06
	BEL 90	285	8.8	40	2.2	0.14	208	7.1	43	1.5	0.12	108	4.2	47	0.6	0.07
	BEL 115	223	9.5	50	3.0	0.16	169	7.6	52	2.0	0.12	115	5.4	54	1.1	0.09
	BEL 150	296	11.8	48	4.4	0.19	260	10.7	49	3.7	0.18	162	7.3	52	1.9	0.12

Based on 60/45°C water and 15°C entering air

Other systems take advantage of the increased efficiencies afforded by low water flow rates and low return water temperatures. In this instance the low flow option would be suitable in order to maintain adequate output (see table below).

Please contact SPC for performance at other conditions.

PERFORMANCE DATA																
Fan Setting		Boost					Medium					Low				
Performance		Air Flow Rate l/s	Output kW	Exit Air Temp C	Pressure Drop kPa	Water Flow Rate l/s	Air Flow Rate l/s	Output kW	Exit Air Temp C	Pressure Drop kPa	Water Flow Rate l/s	Air Flow Rate l/s	Output kW	Exit Air Temp C	Pressure Drop kPa	Water Flow Rate l/s
Model	BEL 40	126	4.8	46	1.6	0.05	101	4.1	48	1.2	0.04	80	3.3	49	0.8	0.03
	BEL 60	212	7.9	46	4.3	0.08	155	6.4	49	3.0	0.06	95	4.4	53	1.6	0.04
	BEL 75	252	8.7	43	6.1	0.09	170	6.7	48	3.9	0.07	99	4.5	53	2.0	0.04
	BEL 90	285	10.6	45	8.6	0.10	208	8.6	49	6.0	0.08	108	5.3	55	2.6	0.05
	BEL 115	223	11.5	57	11.6	0.11	169	9.2	60	7.9	0.09	115	6.7	63	4.5	0.07
	BEL 150	296	14.2	54	16.8	0.14	260	12.9	56	14.2	0.13	162	8.9	60	7.4	0.09

Based on 70/45°C water and 15°C entering air

LOW SURFACE TEMPERATURE UNITS

As a result of SPC's ability to manufacture bespoke it's heat exchangers, units can be supplied to suit low surface temperature applications as required, for example in nurseries. SPC will design suitable heat exchangers based on the hot water system being used to prevent the fan convector casework exceeding the LST threshold.

BELGRAVIA CLASSIC - FAN CONVECTORS

OPTIONS AND ACCESSORIES

A range of optional accessories are available for Belgravia Supreme units, the most popular are shown below.

FACTORY FITTED ACCESSORIES		
	Reference	Function
Thermostat	LTC	Low water temperature fan cutout
	ALTC	Adjustable low water temperature fan cutout
	T1	In-built on-off control
	T2	In-built change speed control
	T1 - T2	Combined on-off/change speed control
	RT1	Remote mounted on-off control
	RT2	Remote mounted change speed control
	TLX1	Tamper-proof on-off stat
	TLX2	Tamper-proof change speed stat
	WIRELESS	Wireless 2 Stage thermostat
Switches*	RS1	On-off rocker switch
	RS2	Summer-winter switch
	RS3	Three speed rocker switch
	RS12	Combined on-off / summer-winter rocker switch
	RS13	Combined on-off / change speed rocker switch
	RS123	Combined on-off summer-winter & change speed rocker switch
	RS23	Combined summer-winter / change speed rocker switch
	MS	Access panel micro switch (unit cutout)
	KOS	Key operated on-off switch
	BOX1F	Metal flush mounting box for single rocker switch
	BOX1S	White plastic surface mounting box for single rocker switch
	BOX2F	Metal flush mounting box for combined rocker switches
	BOX2S	White plastic surface mounting box for combined rocker switches
BMS	BMS1	Relay for remote enable/disable signal
	BMS2	Direct control of fan speed via 0-10V BMS signal
Electrical Connections	FSB	Fuse spur box
	CCB	Customer connection box
Air-side Options	EAV	Extended air vent
	RAF	Reversed airflow
	AF1	Air filter fitted between fan deck and coil
	AF2	Air filter fitted behind the inlet grille
	AF3	Air filter covering the inlet grille fitted to a motor plate
	MOD	Manually operated damper
	POD	Power operated damper
Case Options & Accessories	SPF	Special Paint Finish
	P	Plinth
	LAP	Lockable access panel
	TAP	Tamper proof access panel
	HAP	Hinged access panel
	EXTC	Extended casing
	LGA	Loose grill assembly
	REP	Rounded end panel
	SFP	Stiffened front panel
	SWF	Special white finish
	MTRLV	Motrol diverting valve
	WM	Wall mounted stiffeners
	INVCS	Inverted casing

* Switches are available as case mounted, built-in to the unit or remote mounted.

BELGRAVIA ECO FAN CONVECTORS WITH EC MOTORS
BELGRAVIA CLASSIC - FAN CONVECTORS



ENGINEERING SPECIFICATION

The Belgravia Classic fan convectors shall be manufactured by S & P Coil Products Ltd, SPC House, Evington Valley Road, Leicester. The heaters shall be suitable for the applications as described in the literature, dependent on the model selected. The quantities and model references shall be as indicated in the schedule, with the constructional features complying to the under-mentioned specification.

Case	The case shall be manufactured from medium gauge mild steel throughout, and designed to eliminate distortion and drumming by the use of fully-trayed panels, welded together to form a rigid structure, avoiding any raw edges. The detachable access panel shall be fully-trayed and supported, and be retained by two concealed fasteners. Adequate room is to be provided to house manually operated flow and return valves.
Finish	The metal case shall be degreased and treated with an approved rust-inhibiting and priming process, followed by final coats of colour-specified stove enamel or powder coat finish. Motors to be finished in air-drying paint.
Grilles	Integral or loose grilles to be of linear pattern complying with BSEN 60335, manufactured from extruded aluminium with treated finish. Loose grilles shall have a flange surround, painted as required.
Attachable plinth	Plinth, where called for, shall be manufactured from heavy gauge mild steel, treated and paint-finished to suit.
Filters	Filters shall be a washable-type Bondina P15/150 non-woven polyamide, or equivalent, bonded with synthetic resin, and rated at EU2 arrestance complying with BSEN 779. Filters should be removable for cleaning.
Heat exchangers	The heat exchanger shall be of fin block construction, comprising aluminium fins mechanically bonded to copper primary tubes brazed, in turn, into steel headers having BSP horizontal female flow and return connections at the same end, and rated in accordance with BS 5141. 1/8" BSP air bleed and drain connections to be provided as standard, except on heat exchangers for use with steam.
Test pressure	The heat exchanger shall be tested to 22 bar (2,200kPa) air under water.
Working pressure	All heat exchangers to be suitable for a maximum working pressure of 10 bar (1,000 kPa).
Motor plate, fan & motor assembly	The motor plate assembly shall be readily withdrawable for ease of maintenance, being resiliently mounted on guide rails. Ceiling mounted units should have motor plates fixed by nylock retaining nuts.
Fans	The fan(s) shall be of the double inlet, centrifugal type with forward curved blades. The impeller and scroll shall be from galvanised sheet steel and the impeller shall be directly mounted on the external rotor motor. One or two fans shall be used according to size.
Motors	The motor(s) shall be electronically commutated external rotor type with an in-built electronics enclosure. The motor shall incorporate maintenance free ball bearings. Motors shall be IP44 and insulation class B rated. Rotational speed shall be controlled via a 0-10V signal to be terminal block of the motor.
Wiring & Controls	Provision shall be made for internal wiring with selected control options, and an internally mounted customer connection box shall be provided for interfacing remote options to the unit. All internal wiring shall be rated heat-resistant cable. Unit motors to be suitable for operation with a standard single phase 230V/50Hz supply.
Packaging	Each fan convector shall be despatched in a purpose-made carton which will be clearly marked with the unit model reference and instructions called for in the schedule.
CE Marking	The fan convector shall comply with all relevant EU directives currently in force.



BELGRAVIA ECO FAN CONVECTORS WITH EC MOTORS

BELGRAVIA TILEVECTOR - FAN CONVECTORS

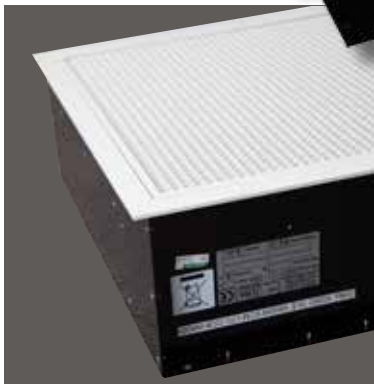
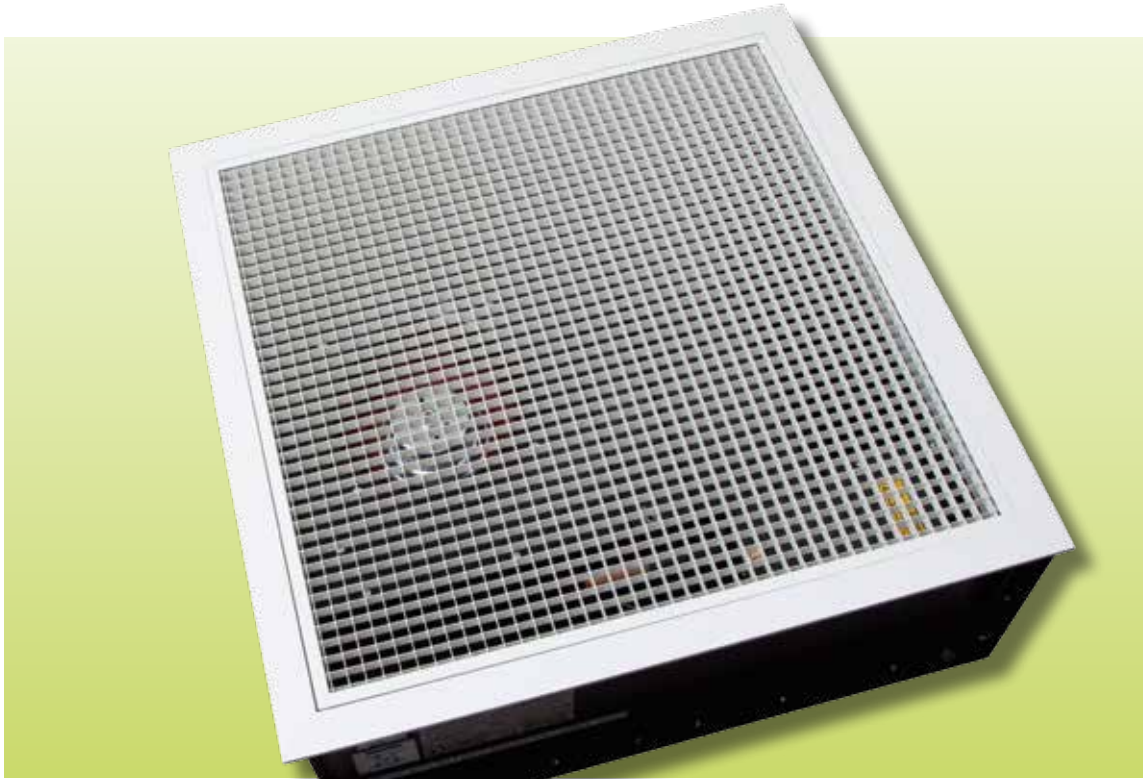

EC MOTORS



CONTROLLABLE

BELGRAVIA ECO FAN CONVECTORS WITH EC MOTORS

BELGRAVIA TILEVECTOR - FAN CONVECTORS

At the heart of the Belgravia Tilevector lies an efficient LPHW heating coil or electrical element. Powerful reliable fans are provided to draw in room air and distribute the conditioned air.

The combination of air throw and rapid energy transfer brings immediate warmth to those below.

Longevity is built in to the Belgravia Tilevector. Apart from routine servicing to clean the filter, the Tilevector's hinged grille will probably remain shut for most of its long life. In fact the Tilevector may well outlast the ceiling in which it is mounted. Once installed, the Tilevector is out of sight and out of mind.

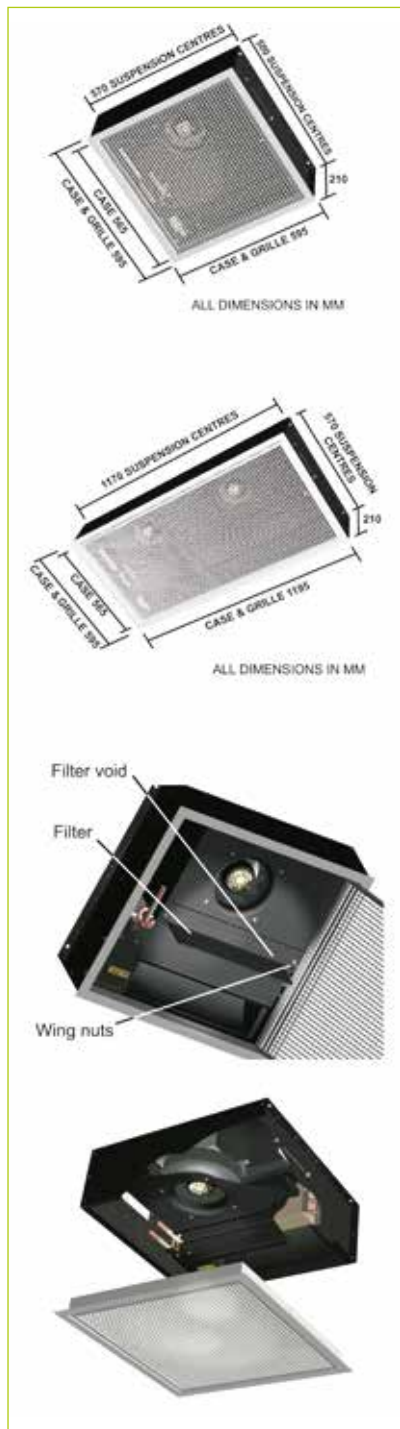

VERSATILE

- ▶ Suitable for suspended plasterboard and T-bar ceilings, as well as solid ceilings
- ▶ Multiple Solo or Duo units can be laid in any configuration within a ceiling grid
- ▶ Choice of LPHW and electric power
- ▶ Range of control options
- ▶ Optionally blows ambient air in summer
- ▶ Slimline 210mm profile for both sizes fits small ceiling voids
- ▶ Ceiling grid locations easily altered to reflect changes of room

POWERFUL

- ▶ Large air volume for immediate heat delivery

AESTHETIC

- ▶ Unobtrusive with low noise
- ▶ Smart appearance enhances the most stylish of locations
- ▶ Liberates valuable wall and floor space
- ▶ Ideal where glass walls, equipment, fixtures or interior design features limit wall space
- ▶ Choice of grille colours (white powder - coated or satin silver aluminium)

TROUBLE - FREE

- ▶ Easy installation with all connections accessible from within the casing
- ▶ Robust construction requires little maintenance
- ▶ Easy servicing via hinged drop -down grille
- ▶ Washable filter
- ▶ All manual & automatic controls are remote

ENERGY - EFFICIENT

- ▶ Low water temperature cut out saves energy and eliminates draughts caused by cold running
- ▶ Optional thermostatic on/off and fan speed controls keep room temperatures steady

BELGRAVIA ECO FAN CONVECTORS WITH EC MOTORS

BELGRAVIA TILEVECTOR - FAN CONVECTORS

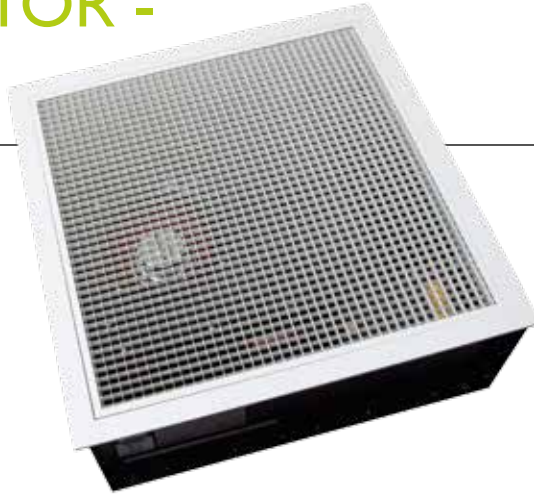

DIMENSIONS

MODEL	SOLO	DUO
Length (mm)	595	1195
Width (mm)	595	
Depth (mm)	210	
Maximum Weight (kg)	18	35



TECHNICAL SPECIFICATION

PERFORMANCE DATA																
Fan Setting		Boost					Medium					Low				
Performance		Air Flow Rate l/s	Output kW	Exit Air Temp C	Pressure Drop kPa	Water Flow Rate l/s	Air Flow Rate l/s	Output kW	Exit Air Temp C	Pressure Drop kPa	Water Flow Rate l/s	Air Flow Rate l/s	Output kW	Exit Air Temp C	Pressure Drop kPa	Water Flow Rate l/s
Model	Solo	95	3.9	49	6.5	0.10	85	3.6	50	5.8	0.09	70	3.2	53	4.7	0.08
	Duo	190	9.0	54	48.7	0.22	170	8.4	56	43.0	0.21	140	7.3	58	34.0	0.18

Based on 80/70°C water and 15°C entering air

CORRECTION FACTORS													
Mean Water Temperature °C		80			70			60			50		
Water Temperature Drop °C		5	10	20	5	10	20	5	10	20	5	10	20
Entering Air Temperature °C	10	1.22	1.19	1.11	1.03	1.00	0.92	0.86	0.81	0.69	0.67	0.61	-
	15	1.14	1.11	1.03	0.94	0.92	0.83	0.78	0.72	0.61	0.58	0.53	-
	20	1.06	1.03	0.94	0.86	0.83	0.75	0.67	0.64	0.50	0.50	0.44	-
	25	0.97	0.92	0.86	0.78	0.75	0.64	0.58	0.56	0.31	0.42	0.33	-

* Factors are approximate. SPC can provide more accurate data if required

FAN ASSEMBLY ELECTRICAL DATA

230 V / 50 HZ SUPPLY										
Fan Setting		High			Medium			Low		
Performance		Airflow (l/s)	EC power draw (W)	EC SPF (W/l/s)	Airflow (l/s)	EC power draw (W)	EC SPF (W/l/s)	Airflow (l/s)	EC power draw (W)	EC SPF (W/l/s)
Model	SOLO	95	18	0.19	85	14	0.16	70	12	0.17
	DUO	190	36	0.19	170	28	0.16	140	24	0.17

NOTES:

1. Dimensions and weights are given including unit cases and grilles
2. Coil supplied with 15mm connections on flow and return
3. Motors are high efficiency EC type
4. Filters are rated at EU-2 arrestance
5. Grilles are hinged, egg-crate style core, all aluminium construction with powder coats or satin-silver finish

BELGRAVIA ECO FAN CONVECTORS WITH EC MOTORS

BELGRAVIA TILEVECTOR - FAN CONVECTORS

NOISE DATA

PERFORMANCE DATA				
Fan Setting		Boost	Medium	Low
Model	Solo	42	40	36
	Duo	44	42	38

NOTES:

1. NR levels are based on a room volume that would normally be heated by a single unit of each size shown
2. Reverberation time of the room is taken to be 0.4 seconds



APPLICATIONS

The LPHW version of the Belgravia Tilevector is equipped with a 2 row heat exchanger so as to provide suitable leaving air temperatures and outputs against conventional hot water supplies.

For applications with low water temperatures or water flow rates an enhanced 3 row coil is available. The outputs are shown in the table below. This option should not be used for high water temperatures as the leaving air temperature becomes unsuitable for a ceiling application.

PERFORMANCE DATA																
Fan Setting		Boost				Medium				Low						
Performance		Air Flow Rate l/s	Output kW	Exit Air Temp C	Pressure Drop kPa	Water Flow Rate l/s	Air Flow Rate l/s	Output kW	Exit Air Temp C	Pressure Drop kPa	Water Flow Rate l/s	Air Flow Rate l/s	Output kW	Exit Air Temp C	Pressure Drop kPa	Water Flow Rate l/s
Model	Solo	90	2.8	41	3.0	0.05	81	2.6	41	2.7	0.04	67	2.3	43	2.1	0.04
	Duo	181	6.7	46	23.7	0.11	162	6.2	47	20.5	0.10	133	5.4	48	16.0	0.09

Based on 60/45°C water and 15°C entering air

FACTORY - FITTED OPTIONS

	LTHW OPTIONS	
Thermostatic Controls	RT1	On/off thermostat (remote)
	RT2	Speed change thermostat (remote)
	ALTC	Adjustable low water temperature cutout
	WIRELESS	Wireless 2 stage thermostat
Switches	RS1	On/off switch (remote)
	RS2	Summer / winter rocker switch (remote)
	RS3	3 speed rocker switch (remote)
Electrical Connections	FSB	Fused spur box for direct mains connection
	CCB	Customer connection box for external controls
BMS	BMS1	Relay for remote enable/disable signal
	BMS2	Direct control of fan speed via 0-10V BMS signal
Coil Connectors	ISV	Isolating valves for flow and return pipes



BELGRAVIA ECO FAN CONVECTORS WITH EC MOTORS

BELGRAVIA TILEVECTOR - FAN CONVECTORS



ENGINEERING SPECIFICATION

The Belgravia TileVector fan convector shall be manufactured by S & P Coil Products Limited, SPC House, Evington Valley Road, Leicester. The heaters shall be suitable for the applications as described in the literature, dependent on the model selected. The quantities and model references shall be indicated in the schedule, with the constructional features complying to the under-mentioned specification.

Case	The casing shall be manufactured from medium gauge mild steel of riveted construction with double thickness mounting flanges. Single or double versions available.
Finish	Metal components shall be degreased and treated, where appropriate, with an approved rust inhibiting and priming process, followed by a final coat of black powder coat finish.
Grilles	The grilles shall be hinged for straightforward installation and servicing. High free area, egg-crate style core, all aluminium construction with white powder coat or satin silver finish.
Filters	Filters shall be a washable type Bondina P15/150 non woven polyamide or equivalent, bonded with synthetic resin, and rated at EU2 arrestance complying with BSEN 779. Filters are removable for cleaning.
Heat exchangers	(a) LPHW: The heat exchanger shall be of fin block construction, comprising aluminium fins mechanically bonded to copper primary tubes brazed, in turn, to 15 mm flow and return pipes. A 1/8" BSP air bleed to be provided as standard, with drainage to be provided by pipe connection breakage. (b) ELECTRIC ELEMENTS: Provided with automatically resetting over heat cut out wired for operation with a standard single phase 230V/ 50 Hz supply.
Test pressure	The heat exchanger shall be tested to 22 bar (2,200 kPa) air under water.
Working pressure	All heat exchangers to be suitable for a maximum working pressure of 10 bar (1,000 kPa).
Fan and motor assembly	The fan assembly shall be mounted, resiliently and directly, into a plenum box mounted on the unit back-panel assembly.
Fans	The fans shall be backward curved for high performance with low noise. They shall be statically and dynamically balanced.
Motors	The motor(s) shall be electronically commutated external rotor type with an in-built electronics enclosure. The motor shall incorporate maintenance free ball bearings. Motors shall be IP44 and insulation class B rated. Rotational speed shall be controlled via a 0-10V signal to the terminal block of the motor.
Wiring & Controls	Units shall be supplied as standard with a low water temperature cut out (integral). Unit motors shall be suitable for operation with a standard single phase 230V/50 Hz supply, the fused terminal block for mains connection to be sited in clear location under grille. All wiring shall be tri rated heat-resistant cable. Provision shall be made for connection of selected control options.
Packaging	Each fan convector shall be despatched in a purpose made carton, which will be clearly marked with the unit model reference and instructions called for in the schedule.
CE Marking	The fan convector shall comply with all relevant EU directives currently in force.

BELGRAVIA ECO FAN CONVECTORS WITH EC MOTORS

FAN CONVECTOR CONFIGURATIONS

BELGRAVIA CLASSIC FAN CONVECTORS - Vertical

REF - BELCAT1 (151)

Unit Size	Case Length	Spigot Length	Extended Case Case Length	Extended Case Spigot Length	Weight (Kg)
30/40	694	640	894	840	32
60	894	840	1194	1140	36
75/90	1194	1140	1494	1440	45
115/150	1494	1440	1694	1640	57

N.B. Most styles available with reversed air flow and / or inverted casing.

Pipe connections 3/4" BSP on all models except the BEL30 which has 1/2" BSP connections

STYLES

BELGRAVIA CLASSIC FAN CONVECTORS - Horizontal

REF - BELCAT2 (151)

Unit Size	Case Length	Spigot Length	Extended Case Case Length	Extended Case Spigot Length	Weight (Kg)
30/40	694	640	894	840	32
60	894	840	1194	1140	36
75/90	1194	1140	1494	1440	45
115/150	1494	1440	1694	1640	57

STYLES

BELGRAVIA CLASSIC FAN CONVECTORS - Reversed Air Flow Unit Styles

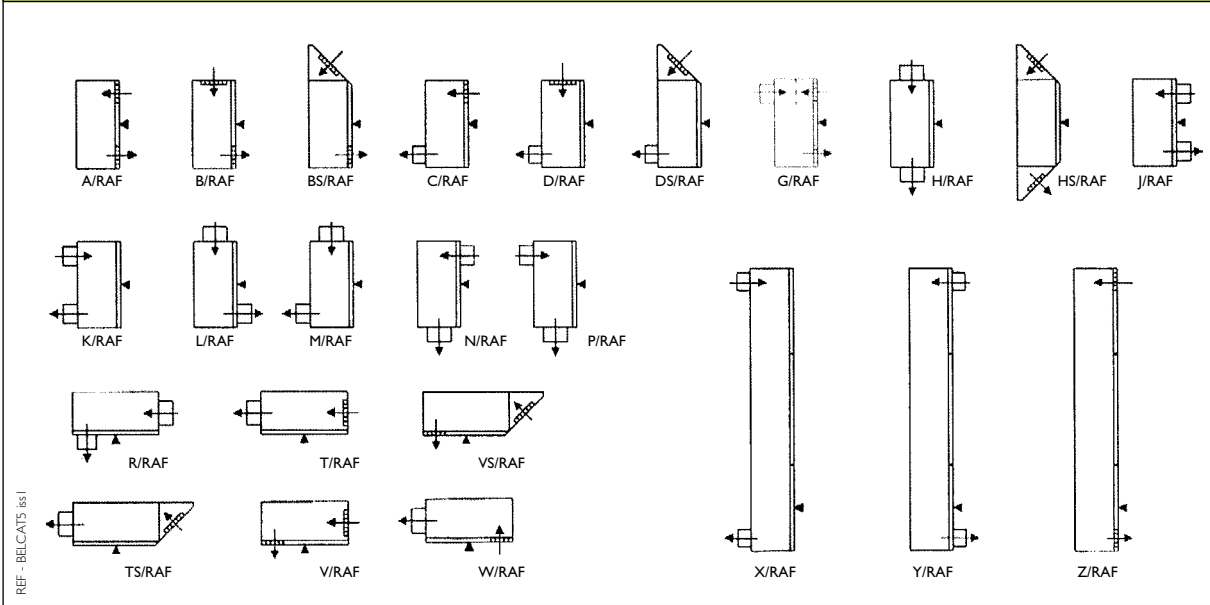

BELGRAVIA CLASSIC FAN CONVECTORS - Inverted Case Unit Styles

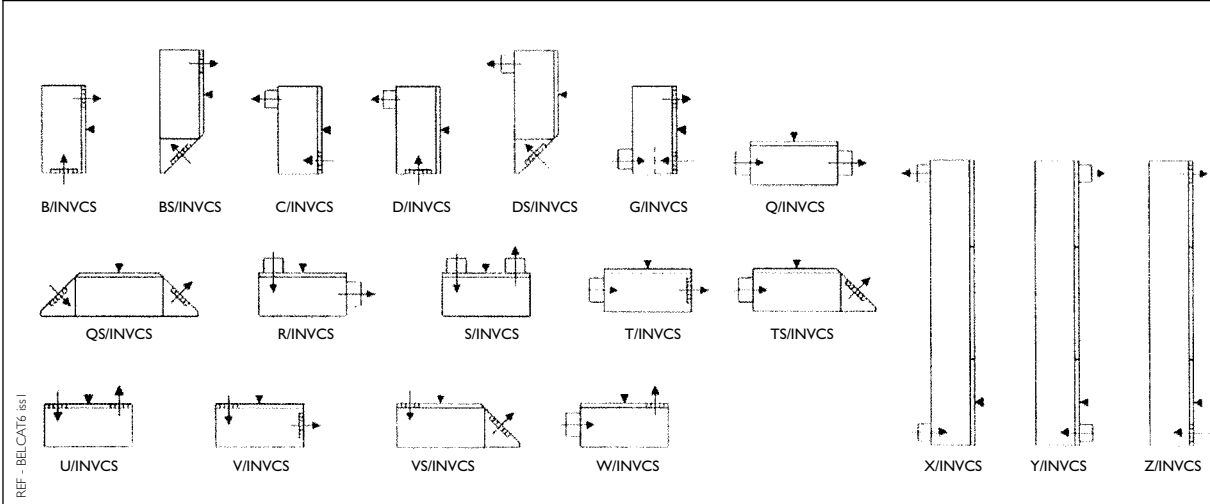

BELGRAVIA CLASSIC FAN CONVECTORS - Inverted Case Reversed Air Flow Unit Styles

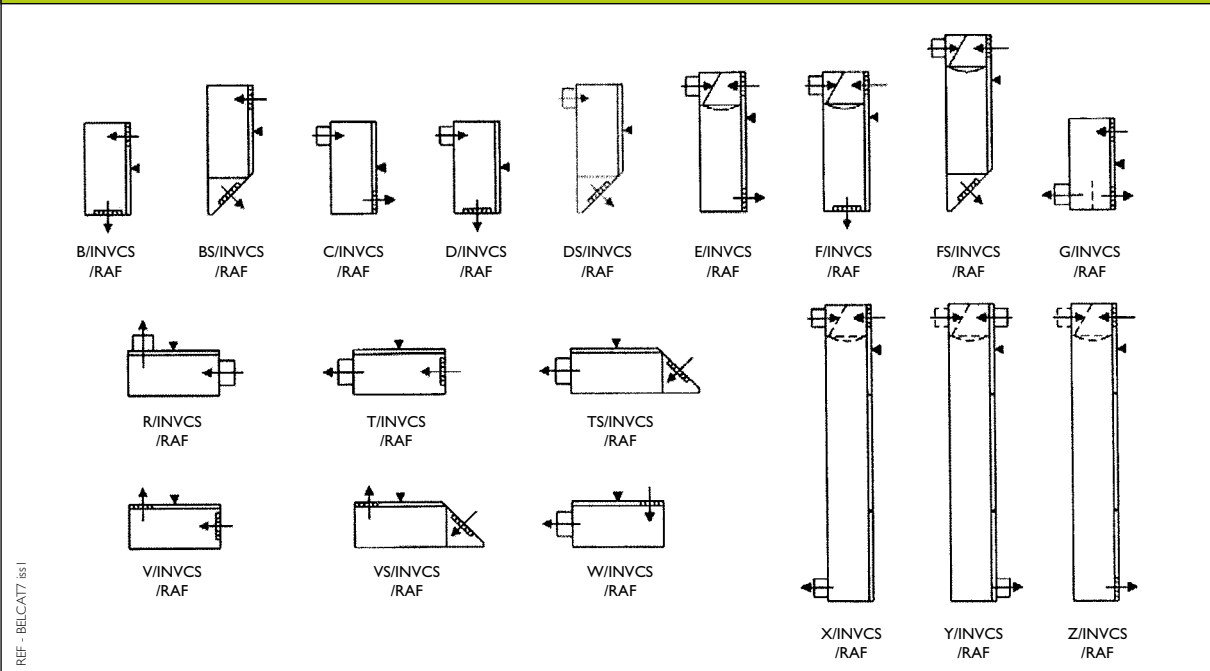

BELGRAVIA CLASSIC FAN CONVECTORS

Damper Units

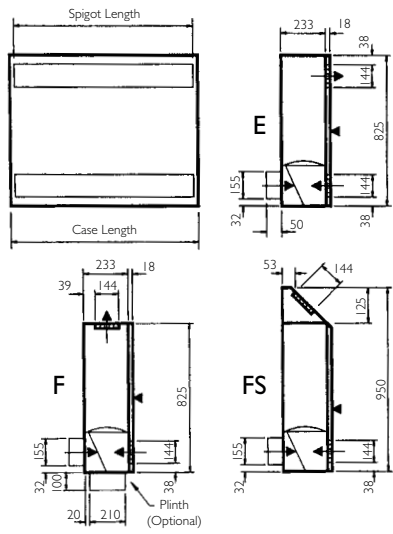

Tall Units

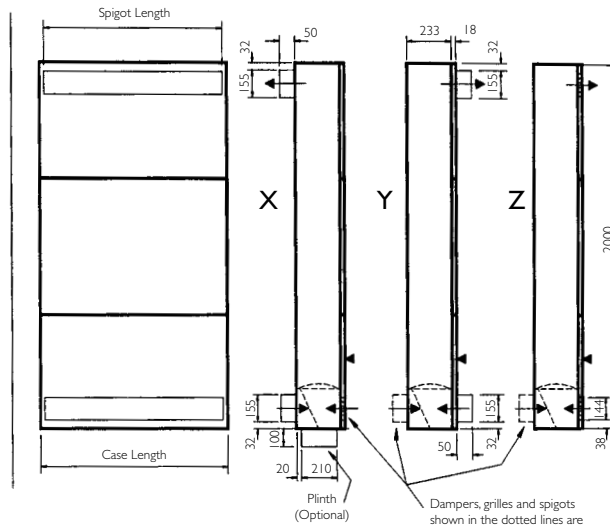

Unit Size	Case Length	Spigot Length	Extended Case Case Length	Extended Case Spigot Length
30/40	694	640	894	840
60	894	840	1194	1140
75/90	1194	1140	1494	1440
115/150	1494	1440	1694	1640

◀ = Access

REF - BELCAT3 ISS1

BELGRAVIA FAN CONVECTORS - Handling

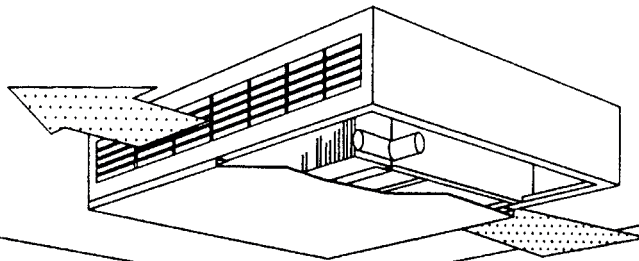

Both units right handed as viewed on front access panel.

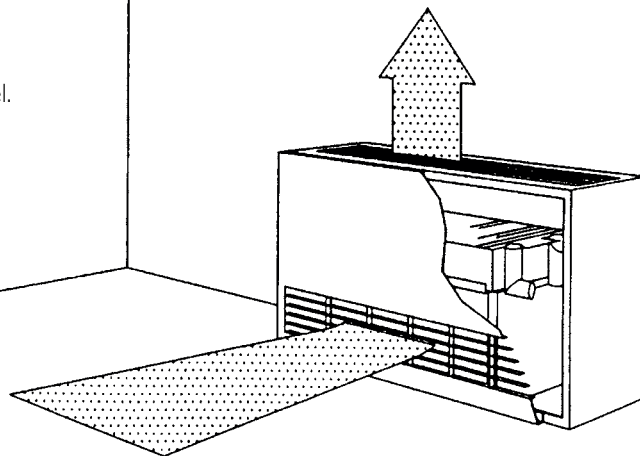

BELGRAVIA ECO FAN CONVECTORS WITH EC MOTORS
FAN CONVECTOR CONFIGURATIONS

BELGRAVIA SUPREME FAN CONVECTORS - Vertical Styles

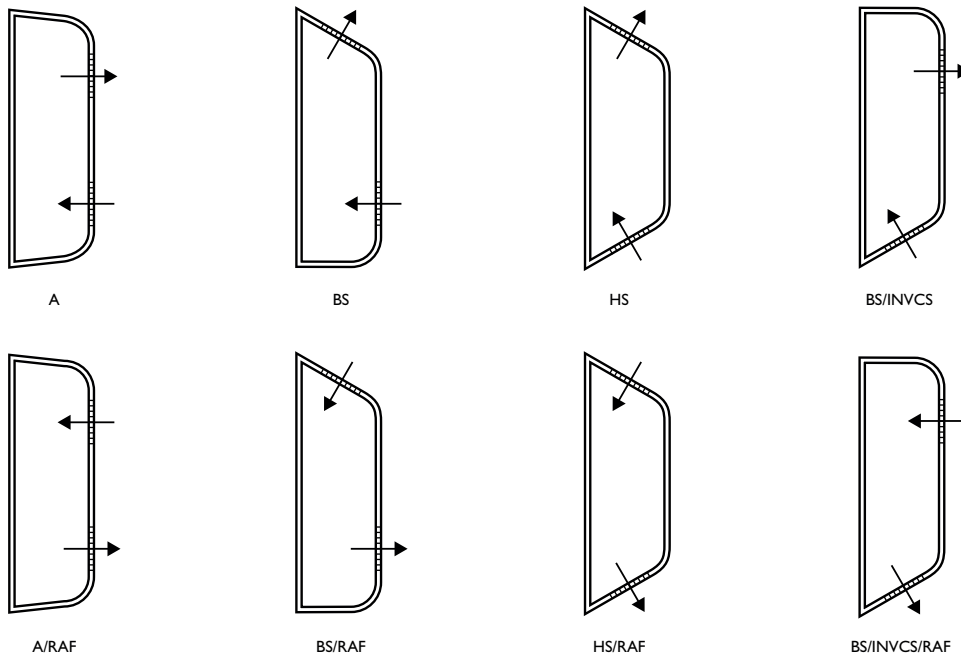

BELGRAVIA SUPREME FAN CONVECTORS - Horizontal Styles

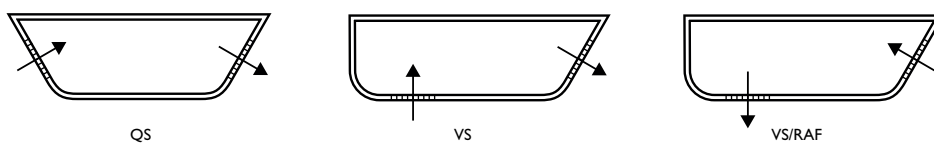

BELGRAVIA SUPREME PLUS FAN CONVECTORS - Styles

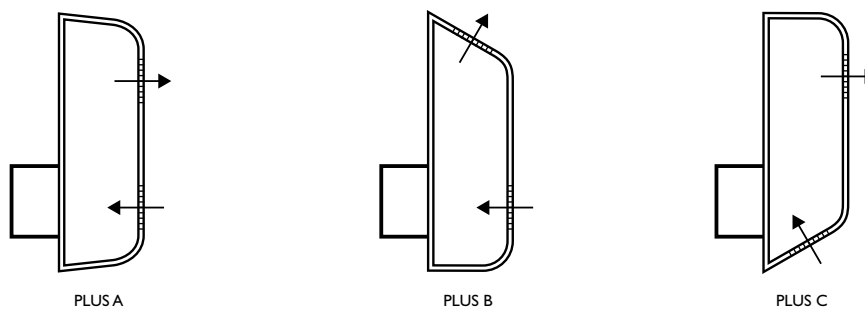

* Also available with FAI spigot at top of unit and reversed air flow



SPC

S & P Coil Products Limited
SPC House, Evington Valley Road, Leicester LE5 5LU
Tel: +44 (0)116 249 0044 Fax: +44 (0)116 249 0033
email: spc@spcoils.co.uk
www.spcoils.co.uk

Ref: FCI Issue 1

