



GAS FIRES



Riva2 750HL with Fluted Vermiculite lining and Victorian Corbel Mantel and Hearth in Limestone with matching slip sets

A Warm Welcome

Nothing creates an inviting atmosphere quite like a Gazco fire. The centrepiece of any home, a Gazco fire adds warmth and character to a room or living space - even if you don't have a chimney!

Whether you want to achieve an up-to-the-minute, contemporary look or have your heart set on a more traditionally designed fire, this brochure will help you make the perfect choice, whatever your style or budget.

Studio Fires (page 8)

Studio.....08



Studio Styling Options.....	16
Studio Edge.....	18
Studio Profil.....	20
Studio Bauhaus.....	22
Studio Expression.....	24
Studio Steel 2.....	26
Studio Glass.....	28
Studio Verve.....	30
Studio Pienza & Firenze.....	36

Studio 22.....32



Studio Slimline.....38



Studio Duplex.....44



Studio Coloured Frame Options.....	48
Gas Riva Vision Stoves.....	50

Eclipse Fires (page 52)

Eclipse.....52



Eclipse Edge.....	54
Eclipse Expression.....	56
Eclipse Verve XS.....	58
Eclipse Icon XS.....	60

Riva2 Fires (page 62)

Riva2 500 & 750HL.....66



Riva2 Styling Options.....	64
Riva2 500 & 750HL Edge.....	68
Riva2 500 & 750HL Evoke Glass.....	70
Riva2 500 & 750HL Evoke Steel.....	72
Riva2 500 & 750HL Verve XS.....	74
Riva2 500 & 750HL Icon XS.....	76
Riva2 500 Ellingham.....	78

Riva2 530 & 670.....80



Riva2 530 & 670 Designio2 Glass.....	82
Riva2 530 & 670 Designio2 Steel.....	84
Riva2 530 & 670 Evoke Glass.....	86
Riva2 530 & 670 Evoke Steel.....	88
Riva2 530 & 670 Verve.....	90
Riva2 530 & 670 Ellingham.....	92
Riva2 670 Verve XS.....	94

Riva2 800 & 1050.....96



Riva2 800 & 1050 Edge.....	98
Riva2 800 & 1050 Icon XS.....	100
Riva2 800 & 1050 Sorrento.....	102

Riva2 Stone Mantels..... 104



Further Information..... 112

Gazco Inset Fires.....	112
Gazco Electric Fires.....	114
Fireplace Tile Surrounds.....	117
Technical Information.....	118



Relax - it's a Gazco Fire...

When you choose Gazco, quality and innovative technology are assured. From traditional models to contemporary designs, Gazco is committed to creating the ultimate flame-effect gas and electric fires.

Our research and development laboratories are amongst the most advanced in the world, ensuring that the very latest innovations are incorporated into our appliances.

Gazco is an ISO9001 accredited company. Our rigorous quality control system ensures that all our appliances comply with British safety standards as well as stringent European regulations. All fires in this brochure are CE marked. This means they have been independently tested to exacting European standards for safety as well as both heating efficiency and emissions.

Warranty

Your Gazco Expert Retailer will provide you with a Five Year Extended Warranty for your new gas fire, provided your fire is registered with Gazco. Please note, this warranty excludes certain consumable parts. Fires purchased outside of Gazco's Expert Retailer Network will carry a standard 1 Year Warranty. Full warranty terms and conditions are available to view at www.gazco.com.



Expert Retailer Network

We take great care to ensure that our fires are designed, tested and manufactured to the highest possible quality and safety standards. We are just as concerned to make certain that they are sold and installed correctly so that you enjoy years of pleasure from your fire.

Accordingly, you will find our products are only available from experienced, independent retailers who will be happy to show you a selection of models locally in their showrooms, often fully operational. These independent retailers will discuss your individual requirements both technical (such as sizing the heat output to your room and advising on your flue type) and design, and ensure that you select the most appropriate product for your home.

They will also be able to advise on, or assist with, the installation process as well as help provide any after-sales support and servicing your appliance may require in the future.

Whilst we encourage our retailers to promote fireplace products and their outlets via the internet, we do not believe suitable levels of customer care and satisfaction can be obtained from purchasing the product only online and we would strongly recommend that you consider this when undertaking your research and making a purchasing decision. Furthermore, please be aware that we do not offer technical support (beyond our statutory responsibilities) to products bought via nationwide online sales, where this support would normally be offered by one of our qualified, independent retailers.



Your Home and Flue Requirements...



The type of chimney or flue you have usually dictates your choice of fire. To help you understand which fires are suitable for your home, please use the following information and pictures to identify your chimney. Don't worry if you don't have a chimney, you can still find the perfect fire for your home!

The fires in this brochure are designed for either a conventional flue or a balanced flue system and the available flue systems are detailed on each product page. Your Gazco retailer will be pleased to provide assistance with your fire selection.

No Air Vent Required (UK)

All fires shown with this symbol have the advantage of not normally requiring an air vent*. Please discuss this in full with your local retailer.

*Requirements in the Republic of Ireland are different.

*Riva2 670 Verve XS in Graphite
with Brick-effect lining*

Conventional Flue

Conventional flue systems are for Gazco's Open Fronted and some Glass Fronted gas fires. They are easily recognisable as either a conventional brick or stone chimney, or as a pre-fabricated chimney system. Should your home have neither at present, it is usually possible to have a pre-fabricated system installed in your home if required.



Brick/Stone Chimney

(Class 1)

The chimney stack rises well above the roofline and is topped by a traditional chimney pot or gas terminal. This type of chimney relies on the natural circulation of heated air to expel the products of combustion up your chimney.



Pre-fabricated Flues

(Class 1 & 2)

You will see a metal flue cowl on your roof. Some are all metal whilst others may terminate through a short rectangular pot (but without a chimney stack). These flues create the same circulation of heated air as a brick or stone chimney.

Balanced Flue

Balanced flues work in conjunction with Gazco's Glass Fronted gas fires only. The appliance is completely sealed from the room into which it is installed (so there are no draughts and heating efficiency is increased) and a twin-wall pipe vents directly to an outside wall.



Balanced Flue

(No chimney required)

Air for combustion is drawn in through the outer pipe whilst the inner pipe removes the combustion gases to the exterior of the property. Depending on the fire selected, the twin-walled pipe may exit horizontally through an external wall or vertically through the roof. Gazco offers a comprehensive range of balanced flue system components. Please refer to our dedicated Concentric Flue System brochure which can be requested from your retailer or viewed online at www.gazco.com.

Electric Fires



Gazco also offers an extensive array of electric fires and stoves in a separate dedicated brochure, all of which do not require a chimney of any kind.



For more information, the Gazco Electric Fires and Stoves brochure is available from your Gazco retailer or you can view the complete range online at www.gazco.com.

Studio Fires

Breathtaking! There really is no better way to describe our stunning Studio fires. With a wealth of design options complemented by a choice of sizes, linings and fuel bed effects, these beautifully contemporary fires will add instant style and presence to any modern interior.



Studio 2 Edge Glass Fronted with Log-effect fuel bed and Vermiculite lining

	Open Fronted Studio Fires			Glass Fronted Studio Fires			Glass Fronted Studio 22	Glass Fronted Studio 1 Slimline	Glass Fronted Studio 2 Duplex
	Studio 1	Studio 2	Studio 3	Studio 1	Studio 2	Studio 3	Studio 22	Studio 1 Slimline	Studio 2 Duplex
Choice of Fuel Bed:									
Realistic Logs	X	X	X	✓	✓	✓	✓	✓	✓
White Stone	✓	✓	✓	✓	✓	✓	X	✓	X
Coloured Glass Beads	✓	✓	✓	✓	✓	✓	X	✓	X
Installation Type:									
Hearth Mounted Installation	X	X	X	X	X	X	✓	X	X
Wall Installation	✓	✓	✓	✓	✓	✓	✓	✓	✓
Cavity Wall Specific Fire	X	X	X	X	X	X	✓ [◇]	✓	X
Double Sided Fire	X	X	X	X	X	X	X	X	✓
Key Features:									
Remote Control	✓	✓	✓	✓	✓	✓	✓	✓	✓
Timer and Thermostat Programmable	X	X	X	✓	✓	✓	✓	✓	✓
Glass Fronted High Efficiency	X	X	X	✓	✓	✓	✓	✓	✓
Ambient Open Fire	✓	✓	✓	X	X	X	X	X	X
Natural Gas or LPG	✓	✓	✓	✓	✓	✓	✓	✓	✓
Choice of Linings	✓	✓	✓	✓	✓	✓	X	✓	✓
Wide Selection of Frames	✓	✓	✓	✓	✓	✓	✓	✓	✓
Frameless 'Edge' Option	✓	✓	✓	✓	✓	✓	✓	✓	✓
Conventional Flue ODS safety device*	✓	✓	✓	✓	✓	n/a	n/a	n/a	n/a
Balanced Flue Firebox Relief Venting System ^Δ	n/a	n/a	n/a	✓	✓	✓	✓	✓	✓
Additional air vent required	X	✓	✓	X	X [†]	X	X	X	X
Conventional Flue	✓	✓	✓	✓	✓	X	X	X	X
Balanced Flue	X	X	X	✓	✓	✓	✓	✓	✓
Maximum Heat Output	1.72kW	2.30kW	3.40kW	5.20kW	6.97kW	7.30kW	5.85kW	4.25kW	7.90kW
Maximum Efficiency	25%	25%	25%	81%	81%	81%	78%	82%	82%

* ODS (Oxygen Depletion Sensor) - This Conventional Flue safety feature will shut off the gas supply to the burner in the event of a reduction to oxygen levels in the room. ^Δ All Gazco Balanced Flue fires have relief vents in the firebox ensuring compliance with EN 613:2001 for delayed ignition safety standards [†] Balanced Flue models only. Conventional flue models will require an air vent. [◇] When installed with a Sorrento surround - see page 35

Four steps to choosing your Studio fire...

The following eight pages will guide you through the wide selection of possibilities and styling options that are synonymous with the Studio range...



Step 1:
Flue Options
(Page 10)



Step 2:
Fuel Effects
(Page 12)



Step 3:
Studio Sizes
(Page 14)



Step 4:
Styling Options
(Page 16)

Studio Flue Types

At the cutting edge of fire design and technology, a Gazco Studio fire can bring the promise of cosy comfort and contemporary style to the heart of your home; even if you don't have a chimney!



Studio 3 Verve Glass Fronted with Log Effect fuel bed and Vermiculite lining

Choosing The Right Studio Fire For Your Home...

The Studio is a versatile and diverse range of fires, with each model having its own special features ranging from visual appeal to heating performance, and styling options to installation possibilities. Depending on the model, there is a wealth of options for both conventional and balanced flue installations. Within the conventional flue selection there are both Open Fronted and Glass Fronted fires, whilst all balanced flue models are available as Glass Fronted only.

Our near invisible Glass Fronted fires have greatly increased heating efficiency whilst maintaining all the visual appeal of the Open Fronted Studios. Furthermore, the balanced flue options make installation possible for most homes, even those without a chimney!

	Studio 1	Studio 2	Studio 3	Studio 22	Studio Slimline	Studio Duplex
Conventional Flue Open Fronted	✓	✓	✓	✗	✗	✗
Conventional Flue Glass Fronted	✓	✓	✗	✗	✗	✗
Balanced Flue Glass Fronted	✓	✓	✓	✓	✓	✓

Conventional Flue Studio Key Features

1. Conventional Flue connection
2. Liner-less installation with no need for additional adapters†
3. Open Fronted or Glass Fronted models
4. Choice of contemporary or realistic fuel effects†
5. Choice of linings†
6. Choice of frame styles
7. Convected and radiant heat†
8. Convected heat system outlet†
9. Simple drop down door for easy maintenance access†
10. Remote control included*
Standard: Open Fronted
Programmable Thermostatic: Glass Fronted
11. External battery holders for ease of battery change
12. Optional mains adaptor

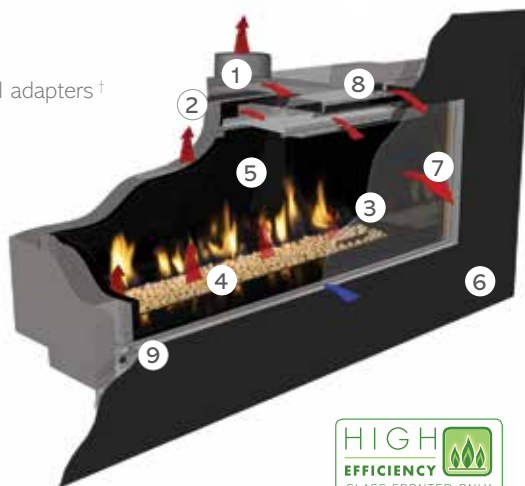

* illustrated below
† Glass fronted models only

Balanced Flue Studio Key Features

1. Balanced Flue connection
2. Variety of flueing options for location flexibility
3. Glass Fronted models
4. Choice of contemporary or realistic fuel effects
5. Choice of linings
6. Choice of frame styles
7. Convected and radiant heat
8. Convected heat system outlet
9. Simple drop down door for easy maintenance access
10. External battery holders for ease of battery change
11. Programmable Thermostatic remote control included*
12. Optional mains adaptor



* illustrated below

Remote Controls

All Open Fronted fires in the Studio range are supplied with a state-of-the-art Standard remote control, allowing you to operate everything from ignition to flame height and heat output from the comfort of your sofa. The Glass Fronted Studios come complete with a Programmable Thermostatic remote that also includes the additional benefits of a programmable timer and thermostatic controls, ensuring that whenever you return home, your house will always be warm and welcoming. Studio fires have an external battery which can be discretely and conveniently located up to 3 metres away from the fire. Alternatively you can choose the optional mains adaptor which negates the need for the batteries altogether. Open Fronted Studios also have a wall mounted, flat Touch Control Panel.



Left: Standard remote for Open Fronted Studio fires

Right: Programmable Thermostatic remote for Glass Fronted Studio fires

Studio Fuel Effects

There are few sights more comforting than the movement of a warming flame. Whether you prefer the ambiance of a real log fire or the more minimalist approach of a stone or glass fuel effect, the Studio range has a choice of fires each showcasing the flames to their maximum potential.



*Studio 2 Glass Open Fronted
with Black Glass Bead fuel bed*

Your Studio, Your Way...

Once you have identified whether you require a conventional or balanced flue fire, you can then decide upon which fire type is suitable for your heating and interior design needs. The wealth of options available are all based around three main types of fire: Open Fronted with white stone or glass bead fuel bed, Glass Fronted with white stone or glass bead fuel bed and Glass Fronted with

realistic log-effect fuel bed. Each of these stunning Studio fires is available with a whole host of decorative styles (see page 16-17) and is testament to Gazco's continued investment into inspired product design.

Open Studio - White Stone and Glass Bead Fuel Beds

All Open Studio fires incorporate Gazco's ultra contemporary flame-effect: a single ribbon of modulating flames dancing over a bed of small white stones, beautifully reflected by the sparkling stainless front plate. There is also the additional option of a polished black granite interior to further increase the reflective qualities of the fire. You can customise your white stone fire with one of three optional glass bead sets which will enhance the ribbon flames when the fire is on, yet look equally fantastic when the fire is off. Open Studios are one of the few gas fires on the market that allow the possibility of installing a Plasma, LCD or LED television above them for a great visual centrepiece*. Please see page 118 for full details.

Glass Fronted Studio - White Stone and Glass Bead Fuel Beds



Glass Fronted Studios benefit from greatly increased heat output, boasting up to 82% efficiency. The standard features of the Studio Open are also incorporated into this fire choice, including the white stone and glass bead options as well as the distinctive ribbon flames, all displayed to the full by the contrasting backdrop of a reflective black enamelled lining. According to fire size, there are options for both conventional and balanced flue installations, making the Studio suitable for a wide range of homes, even those without a chimney.

Glass Fronted Studio – Log-effect Fuel Bed



This high efficiency fire choice offers the ideal solution for those looking to make a modern style statement, yet still wanting to enjoy the heart-warming ambiance traditionally associated with a real log fire. This enticing atmosphere is achieved by the long and lazy flames snaking through highly realistic hand-painted logs and beautifully enhanced by an innovative glowing ember effect for the ultimate 'real fire' look. According to size, this version is available in both balanced flue and conventional flue variants and can also benefit from a choice of lining options, further details of which can be found on page 16.

*Open Fronted only. Please note that due to the higher efficiency of the Glass Fronted Studio's, Gazco does not recommend installing televisions above these fires.

** Please note that the Red Glass beads will darken when burning and then return to their original colour when cool.



Open Fronted Studio with White Stones

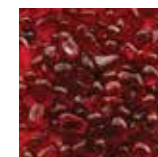

Red Glass Beads**



Black Glass Beads



Glass Fronted Studio with White Stones



Clear Glass Beads



Glass Fronted Studio with Log-effect

Studio Sizes

The outstanding Studio fires range is available in up to four different sizes, offering greater installation possibilities for interiors of all proportions. With three landscape sizes and a portrait option alongside the latest Slimline and double-sided Duplex options, the beautifully designed Studio fires are the perfect blend of versatility and style.



*Studio 22 Profil, Glass Fronted
with Log effect fuel bed*

Studio 1

Available as an Open Fronted model with white stone or glass bead fuel beds, or as Glass Fronted versions with the additional fuel-effect choice of a realistic log bed. The Open Fronted produces a heat output of up to 1.72kW whilst the Glass Fronted offers up to 5.20kW, greatly increased efficiency and balanced flue versions.



Studio 1 with White Stone fuel bed

Studio 2

Available as an Open Fronted version with either a white stone or a glass bead fuel bed; or as a Glass Fronted version, which has the additional choices of a realistic log-effect fire and balanced flue options. The Studio 2 fires, being wider, produce greater heat outputs than those generated by the Studio 1; up to 2.30kW is offered by the Open Fronted models whilst the Glass Fronted fires produce up to 6.97kW.



Studio 2 with Log effect fuel bed

Studio 3

The largest in the range, the Studio 3 is available in both Open Fronted or Glass Fronted versions. The Open Fronted produces a heat output of up to 3.40kW and is available with either a white stone fuel bed or a glass bead fuel bed; whilst the Studio 3 Glass Fronted has the additional option of the realistic log-effect fire choice. Due to its impressive 7.30kW of heat output, the Glass Fronted is for balanced flue installations only, making it perfect for homes that do not have a chimney!



Studio 3 with White Stone fuel bed

Studio 1 Slimline



The high efficiency Slimline has been specifically designed for cavity wall installations. Available with a choice of white stone, glass bead or realistic log fuel beds, this Glass Fronted fire offers a heat output of up to 4.25kW and a balanced flue installation. For more information, please see pages 38-43.

Studio 2 Duplex



A double-sided high efficiency fire which can be enjoyed from two rooms at once! This Glass Fronted fire is available with a realistic log fuel bed and produces up to 7.9kW of heat output. Please see pages 44-47 for further details on this eye-catching balanced flue fire.

Studio 22



Available with a highly realistic log-effect fuel bed and balanced flue installation, the Glass Fronted Studio 22 produces up to 5.85kW of heat output, offering great efficiency as well as style. There are several frames available to enhance and add instant presence to this attractive portrait fire.

Please see pages 32-35 for further details on the Studio 22.

Heat output and efficiency figures are based upon the maximum heat output achieved in the options available for each model. For further technical information please refer to the technical section at the rear of this brochure.

Studio Styling Options

Studio Lining Options

Depending on model, several Gazco Studio fires can be customised with a choice of lining options, each offering a dramatically different aesthetic for your fire. The Open Fronted Studios have a black steel interior, that can be upgraded to a polished black granite lining to boost the reflective qualities. Glass Fronted Studios with a log-effect fire can be specified with either a vermiculite or black reeded lining. Glass Fronted Studios with a white stone or glass bead fuel bed have an enamelled lining only. The exception to these are the Studio 1 Slimline fires, where an additional option of a brick lining is available alongside the vermiculite or black reeded options (see pages 38 - 43 for full details on Studio Slimline options).



Vermiculite Lining
(Available with Log-effect Studios)



Black Reeded Lining
(Available with Log-effect Studios)



Polished Black Granite
(Open Studio Upgrade)

Studio Frame Options

These pages outline the many different frame options available for the Studio fires, all of which are shown in detail throughout the brochure. These stunning frame options have all been designed specifically to complement the contemporary visuals of the Studio range and offer you a spectrum of different styling possibilities.

Crafted from high quality materials such as sparkling glass, stylish steel and natural stone, the extensive Studio frame selection is the perfect way to personalise your premium Studio fire and will ensure you achieve the designer look in your home - whatever your decorative tastes!

Studio Coloured Frame Options

For those who want to add a splash of colour to their living space, Studio Profil, Bauhaus, Expression, Verve and Steel2 frames are also available in three eye-catching colours; Metallic Red, Metallic Bronze and Ivory. For full details please see pages 48 - 49.

	Pages	Studio 1		Studio 2		Studio 3		Studio 22	Studio Slimline	Studio Duplex
		(Open Fronted)	(Glass Fronted)	(Open Fronted)	(Glass Fronted)	(Open Fronted)	(Glass Fronted)	(Glass Fronted)	(Glass Fronted)	(Glass Fronted)
Edge	18 - 19	✓	✓	✓	✓	✓	✓	✓	✓	✓
Profil	20 - 21	✓	✓	✓	✓	✓	✓	✓	✓	✓
Bauhaus	22 - 23	✓	✓	✓	✓	✓	✓	✓	✓	✓
Expression	24 - 25	X	✓	X	✓	X	✓	✓	✓	✓
Steel 2	26 - 27	✓	✓	✓	✓	✓	✓	✓	✓	✓
Glass	28 - 29	✓	✓	✓	✓	✓	✓	X	✓	✓
Verve	30 - 31	✓	✓	✓	✓	✓	✓	✓	✓	✓
Sorrento	34 - 35	X	X	X	X	X	X	✓	X	X
Pienza & Firenza	36 - 37	✓	X	✓	X	X	X	X	X	X



Studio Edge, Glass Fronted with White Stone fuel bed



Studio Edge, Glass Fronted with Log-effect fuel bed



Studio Steel 2 - Graphite



Studio Expression - Graphite



Studio Profil - Anthracite or Polished Stainless Steel



Studio Bauhaus - Anthracite or Polished Stainless Steel



Studio Glass



Studio Verve - Graphite (Horizontal Curve) Aerial View Below



Studio Firenze - Granite



Studio Pienza - Limestone



Studio Sorrento - Natural Limestone



Studio Sorrento - Graphite Granite

Studio Edge



Studio 2 Edge, Open Fronted[^] with White Stone fuel bed



Studio 2 Edge, Glass Fronted with Log-effect fuel bed and Vermiculite lining

This stunning 'hole in the wall' fire creates a visual delight in any living space. Its central feature is a modulating single ribbon of living flame that dances above a bed of white stones or glass beads or through a realistic log-effect display. Additionally, any white stone models can be retro-fitted with any of the red, clear or black glass bead fuel effect options to create a new stylish look.

The Studio Edge is for those who require minimalist modern perfection. The fire has an eye-catching no-frame* design, with the option on the Open Fronted Studio fires of a polished black granite interior lining offering mirror-like qualities that reflect the continuous motion of the flames and accentuate the contemporary appeal of the fire.

See page 8 for additional image.

Linings

- Black Steel (Open Fronted Standard)
- Polished Granite (Open Fronted Upgrade)
- Black Enamel (Glass Fronted - White Stones or Glass Beads)
- Black Reeded (Glass Fronted - Logs)
- Vermiculite (Glass Fronted - Logs)

Fuel Beds

- White Stones
- Glass Beads - Red, Clear or Black (White Stone Upgrade)
- Logs (Glass Fronted only)

Command Controls

- Standard remote - Open Fronted
- Programmable Thermostatic remote - Glass Fronted



Fire Choices (see pages 8 - 15)

Fire Choices (see pages 8 - 15)	Efficiency	Heat Output	Dimensions [^] w x h (mm)
Studio 1 – Open Fronted, Conventional Flue	25%	1.72kW	660 x 334
Studio 1 – Glass Fronted, Conventional Flue	70%	4.85kW	752 x 428
Studio 1 – Glass Fronted, Balanced Flue	81%	5.20kW	745 x 416
Studio 2 – Open Fronted, Conventional Flue	25%	2.30kW	860 x 334
Studio 2 – Glass Fronted, Conventional Flue	78%	6.85kW	952 x 428
Studio 2 – Glass Fronted, Balanced Flue	81%	6.97kW	945 x 416
Studio 3 – Open Fronted, Conventional Flue	25%	3.40kW	1250 x 334
Studio 3 – Glass Fronted, Balanced Flue	81%	7.30kW	1335 x 416

Other models available: Studio 22 (pages 32 - 35), Studio Slimline (pages 38 - 43) & Studio Duplex (pages 44 - 47)

*No-frame refers to added exterior frames. Glass Fronted Studios have an additional 27mm inner frame that secures the glass window in place. Glass Fronted fires for Edge installation will require a kit as shown on page 121.

[^]Dimensions given are those overall visible upon installation. Efficiency figures are based upon the maximum heat output achieved in the options available. For more detailed technical information, including firebox dimensions, installation and flue gather requirements, along with information on installing televisions above Open Studio fires, please see pages 118-121.



Studio 3 Edge, Open Fronted with White Stone fuel bed and Granite lining.



Studio Profil



Innovative glowing ember Log-effect fuel bed



Studio 1 Profil, Open Fronted^Δ in Polished Stainless Steel finish with Clear Glass Bead fuel bed



Studio 2 Profil, Glass Fronted in Anthracite finish with Log-effect fuel bed and Vermiculite lining

The Studio Profil features timeless, simplistic styling that fits in perfectly with virtually all interiors. Furthermore, the Studio Profil offers you five stunning frame colour choices from sophisticated Anthracite to expressive Metallic Red and is available on all sizes and fuel types of Studio fires.

Finishes

- Anthracite
- Polished Stainless Steel
- Metallic Red
- Metallic Bronze
- Ivory

Colour options shown on pages 48-49

Linings

- Black Steel (Open Fronted Standard)
- Polished Granite (Open Fronted Upgrade)
- Black Enamel (Glass Fronted - White Stones or Glass Beads)
- Black Reeded (Glass Fronted - Logs)
- Vermiculite (Glass Fronted - Logs)

Fuel Beds

- White Stones
- Glass Beads - Red, Clear or Black (White stone upgrade)
- Logs (Glass Fronted only)

Command Controls

- Standard remote - Open Fronted
- Programmable Thermostatic remote - Glass Fronted



Fire Choices (see pages 8 - 15)

		Efficiency	Heat Output	Dimensions ^Δ w x h (mm)
Studio 1 – Open Fronted, Conventional Flue		25%	1.72kW	750 x 426
Studio 1 – Glass Fronted, Conventional Flue		70%	4.85kW	846 x 520
Studio 1 – Glass Fronted, Balanced Flue		81%	5.20kW	836 x 510
Studio 2 – Open Fronted, Conventional Flue		25%	2.30kW	950 x 426
Studio 2 – Glass Fronted, Conventional Flue		78%	6.85kW	1046 x 520
Studio 2 – Glass Fronted, Balanced Flue		81%	6.97kW	1036 x 510
Studio 3 – Open Fronted, Conventional Flue		25%	3.40kW	1340 x 426
Studio 3 – Glass Fronted, Balanced Flue		81%	7.30kW	1426 x 510
Other models available: Studio 22 (pages 32 - 35), Studio Slimline (pages 38 - 43) & Studio Duplex (pages 44 - 47)				

^Δ Dimensions given are those overall visible upon installation. Efficiency figures are based upon the maximum heat output achieved in the options available. For more detailed technical information, including firebox dimensions, installation and flue gather requirements, along with information on installing televisions above Open Studio fires, please see pages 118-121.

Studio Bauhaus



Studio 1 Bauhaus, Open Fronted in Anthracite finish with White Stone fuel bed



Studio 2 Bauhaus Conventional Flue, Glass Fronted in Polished Stainless Steel with Log-effect fuel bed and Black Reeded lining

The Studio Bauhaus features a classic three dimensional tapered frame that comes in two finishes as standard, Anthracite and Polished Stainless Steel. Three additional colour choices are also available, enabling you to perfectly match the Bauhaus to the style of your room. Your interior design possibilities continue with options for either the black reeded or vermiculite linings on the log-effect models, or the optional red, black or clear glass beads to replace the white stone fuel effect.

Finishes

Anthracite
Polished Stainless Steel
Metallic Red
Metallic Bronze
Ivory

Colour options shown on pages 48-49

Linings

Black Steel (Open Fronted Standard)
Polished Granite (Open Fronted Upgrade)
Black Enamel (Glass Fronted - White Stones or Glass Beads)
Black Reeded (Glass Fronted - Logs)
Vermiculite (Glass Fronted - Logs)

Fuel Beds

White Stones
Glass Beads - Red, Clear or Black[†]
Logs (Glass Fronted only)

Command Controls

Standard remote - Open Fronted
Programmable Thermostatic remote - Glass Fronted



Fire Choices (see pages 8 - 15)

	Efficiency	Heat Output	Dimensions ^Δ w x h (mm)
Studio 1 – Open Fronted, Conventional Flue	25%	1.72kW	764 x 439
Studio 1 – Glass Fronted, Conventional Flue	70%	4.85kW	860 x 534
Studio 1 – Glass Fronted, Balanced Flue	81%	5.20kW	850 x 524
Studio 2 – Open Fronted, Conventional Flue	25%	2.30kW	964 x 439
Studio 2 – Glass Fronted, Conventional Flue	78%	6.85kW	1060 x 534
Studio 2 – Glass Fronted, Balanced Flue	81%	6.97kW	1050 x 524
Studio 3 – Open Fronted, Conventional Flue	25%	3.40kW	1354 x 439
Studio 3 – Glass Fronted, Balanced Flue	81%	7.30kW	1440 x 524

Other models available: Studio 22 (pages 32 - 35), Studio Slimline (pages 38 - 43) & Studio Duplex (pages 44 - 47)

^Δ Dimensions given are those overall visible upon installation. Efficiency figures are based upon the maximum heat output achieved in the options available. For more detailed technical information, including firebox dimensions, installation and flue gather requirements, along with information on installing televisions above Open Studio fires, please see pages 118-121.



Studio 3 Bauhaus, Glass Fronted in Stainless Steel finish with Log-effect fuel bed and Vermiculite lining

Studio Expression



Studio 2 Expression, Glass Fronted in Graphite with Log-effect fuel bed and Black Reeded lining



Studio 1 Expression, Glass Fronted in Graphite with White Stone fuel bed

The Expression is the latest frame to grace the Studio Glass-fronted gas fires range. Simple, stylish and sophisticated, the Expression offers a complete focal point around which to express your very own decorative style.

The deep profile of the Expression frame has a simple, smooth design in high grade steel, perfectly proportioned to complement and frame the eye-catching realistic log, contemporary glass or white stone flame pictures within. Available in bold Graphite with additional choices of the three vibrant finishes, the Expression Steel offers timeless simplicity or a striking centrepiece to fit with a wealth of interior decors.

Finishes

Graphite
Metallic Red
Metallic Bronze
Ivory

Colour options shown on pages 48-49

Linings

Black Enamel (Glass Fronted - White Stones or Glass Beads)
Black Reeded (Glass Fronted - Logs)
Vermiculite (Glass Fronted - Logs)

Fuel Beds

White Stones
Glass Beads - Red, Clear or Black (White Stone upgrade)
Logs

Command Controls

Programmable Thermostatic remote



Fire Choices (see pages 8 - 15)

		Efficiency	Heat Output	Dimensions [^] w x h (mm)
Studio 1 – Glass Fronted, Conventional Flue		70%	4.85kW	950 x 624
Studio 1 – Glass Fronted, Balanced Flue		81%	5.20kW	940 x 614
Studio 2 – Glass Fronted, Conventional Flue		78%	6.85kW	1150 x 624
Studio 2 – Glass Fronted, Balanced Flue		81%	6.97kW	1140 x 614
Studio 3 – Glass Fronted, Balanced Flue		81%	7.30kW	1530 x 614

Other models available: Studio 22 (pages 32 - 35), Studio Slimline (pages 38 - 43) & Studio Duplex (pages 44 - 47)

[^]Dimensions given are those overall visible upon installation. Efficiency figures are based upon the maximum heat output achieved in the options available. For more detailed technical information, including firebox dimensions, installation and flue gather requirements. Please see pages 118 - 121.



Studio 3 Expression, Glass Fronted in Graphite with Log-effect fuel bed and Vermiculite lining



Studio Steel 2



Studio 2 Steel 2, Glass Fronted in Graphite with Log-effect fuel bed and Black Reeded lining



Studio 1 Steel 2, Open Fronted in Metallic Red with White Stone fuel bed

The Studio Steel 2 is for those with larger spaces who wish to create a greater presence with their choice of fireplace. The Studio Steel 2's wide frame instantly creates a distinctive and individual focal point that can be further heightened by your choice of frame colour. Furthermore, why not create a whole new look by taking advantage of the vermiculite or black reeded linings for log-effect Studios or upgrading a white stone fuel effect to one of three coloured glass bead options. Operation is simplicity itself, as Gazco's remote control takes care of everything from ignition to flame height adjustment.

Finishes

Graphite
Metallic Red
Metallic Bronze
Ivory

Colour options
shown on pages
48-49

Linings

Black Steel (Open Fronted Standard)
Polished Granite (Open Fronted Upgrade)
Black Enamel (Glass Fronted - White Stones
or Glass Beads)
Black Reeded (Glass Fronted - Logs)
Vermiculite (Glass Fronted - Logs)

Fuel Beds

White Stones
Glass Beads - Red, Clear or Black (White stone upgrade)
Logs (Glass Fronted only)

Command Controls

Standard remote - Open
Fronted
Programmable Thermostatic
remote - Glass Fronted



Fire Choices (see pages 8 - 15)

	Efficiency	Heat Output	Dimensions ^A w x h (mm)
Studio 1 – Open Fronted, Conventional Flue	25%	1.72kW	1118 x 478
Studio 1 – Glass Fronted, Conventional Flue	70%	4.85kW	1264 x 528
Studio 1 – Glass Fronted, Balanced Flue	81%	5.20kW	1264 x 528
Studio 2 – Open Fronted, Conventional Flue	25%	2.30kW	1354 x 508
Studio 2 – Glass Fronted, Conventional Flue	78%	6.85kW	1500 x 528
Studio 2 – Glass Fronted, Balanced Flue	81%	6.97kW	1500 x 528
Studio 3 – Open Fronted, Conventional Flue	25%	3.40kW	1844 x 528
Studio 3 – Glass Fronted, Balanced Flue	81%	7.30kW	1990 x 528

Other models available: Studio 22 (pages 32 - 35), Studio Slimline (pages 38 - 43) & Studio Duplex (pages 44 - 47)

^A Dimensions given are those overall visible upon installation. Efficiency figures are based upon the maximum heat output achieved in the options available. For more detailed technical information, including firebox dimensions, installation and flue gather requirements, along with information on installing televisions above Open Studio fires, please see pages 118-121.



Studio 2 Glass, Glass Fronted with Log-effect fuel bed and Black Reeded lining

Studio Glass



Open Fronted White Stone fuel bed



Studio 1 Glass, Glass Fronted with Log-effect fuel bed and Vermiculite lining. Shown with Gazco's Pretoria Anthracite Matt fire surround tiles



Studio 2 Glass, Glass Fronted with White Stone fuel bed

Sleek, chic and shining, the black Glass offers you a striking focal point around which you can create your own distinctive interior. Available in three sizes of Open and Glass Fronted versions, and with a choice of white stones, glass beads or log-effect fuel beds, there's a Studio Glass to offer instant impact whatever your room size.

A further image of the Studio Glass is shown on page 12.

Finish

Black Glass

Fuel Beds

White Stones
Glass Beads - Red, Clear or Black (White stone upgrade)
Logs (Glass Fronted only)

Linings

Black Steel (Open Fronted Standard)
Polished Granite (Open Fronted Upgrade)
Black Enamel (Glass Fronted - White Stones or Glass Beads)
Black Reeded (Glass Fronted - Logs)
Vermiculite (Glass Fronted - Logs)

Command Controls

Standard remote
- Open Fronted
Programmable Thermostatic remote - Glass Fronted



Fire Choices (see pages 8 - 15)

	Efficiency	Heat Output	Dimensions [^] w x h (mm)
Studio 1 – Open Fronted, Conventional Flue	25%	1.72kW	1264 x 528
Studio 1 – Glass Fronted, Conventional Flue	70%	4.85kW	1264 x 528
Studio 1 – Glass Fronted, Balanced Flue	81%	5.20kW	1264 x 528
Studio 2 – Open Fronted, Conventional Flue	25%	2.30kW	1500 x 528
Studio 2 – Glass Fronted, Conventional Flue	78%	6.85kW	1500 x 528
Studio 2 – Glass Fronted, Balanced Flue	81%	6.97kW	1500 x 528
Studio 3 – Open Fronted, Conventional Flue	25%	3.40kW	1990 x 528
Studio 3 – Glass Fronted, Balanced Flue	81%	7.30kW	1990 x 528

Other models available: Studio Slimline (pages 38 - 43) & Studio Duplex (pages 44 - 47)

[^] Dimensions given are those overall visible upon installation. Efficiency figures are based upon the maximum heat output achieved in the options available. For more detailed technical information, including firebox dimensions, installation and flue gather requirements, along with information on installing televisions above Open Studio fires, please see pages 118-121.

Studio Verve



Studio 2 Verve, Glass Fronted in Graphite with Log-effect fuel bed and Vermiculite lining



Studio 1 Verve, Glass Fronted in Graphite with Log-effect fuel bed and Black Reeded lining

With an eye-catching 3D curve and four stylish finishes, the Studio Verve instantly creates a designer look in your living room and is the perfect way to accentuate the modern landscape flame picture provided by each of the three fire sizes.

Whether your choice is the stunning ribbon flame effect of the white stone and glass bead fuel beds or the allure of the highly realistic log-effect fire option, the Studio Verve is a gas fire that can be appreciated from all angles. A further image of the Studio Verve can be found on page 10.

Finishes

Graphite
Metallic Red
Metallic Bronze
Ivory

Colour options
shown on pages
48-49

Linings

Black Steel (Open Fronted Standard)
Polished Granite (Open Fronted Upgrade)
Black Enamel (Glass Fronted - White
Stones or Glass Beads)
Black Reeded (Glass Fronted - Logs)
Vermiculite (Glass Fronted - Logs)

Fuel Beds

White Stones
Glass Beads - Red, Clear or Black (White
stone upgrade)
Logs (Glass Fronted only)

Command Controls

Standard remote - Open
Fronted
Programmable Thermostatic
remote - Glass Fronted



Fire Choices (see pages 8 - 15)

	Efficiency	Heat Output	Dimensions ^A w x h (mm)
Studio 1 – Open Fronted, Conventional Flue	25%	1.72kW	1264 x 528
Studio 1 – Glass Fronted, Conventional Flue	70%	4.85kW	1264 x 528
Studio 1 – Glass Fronted, Balanced Flue	81%	5.20kW	1264 x 528
Studio 2 – Open Fronted, Conventional Flue	25%	2.30kW	1500 x 528
Studio 2 – Glass Fronted, Conventional Flue	78%	6.85kW	1500 x 528
Studio 2 – Glass Fronted, Balanced Flue	81%	6.97kW	1500 x 528
Studio 3 – Open Fronted, Conventional Flue	25%	3.40kW	1990 x 528
Studio 3 – Glass Fronted, Balanced Flue	81%	7.30kW	1990 x 528

Other models available: Studio 22 (pages 32 - 35), Studio Slimline (pages 38 - 43) & Studio Duplex (pages 44 - 47)

^ADimensions given are those overall visible upon installation. Efficiency figures are based upon the maximum heat output achieved in the options available. For more detailed technical information, including firebox dimensions, installation and flue gather requirements, along with information on installing televisions above Open Studio fires, please see pages 118-121.



Studio 3 Verve in Graphite, Open Fronted with White Stone fuel bed

Studio 22



Studio 22 Profil in Anthracite



Studio 22 Verve in Graphite, shown with Gazco's Burnt Sienna fire surround tiles

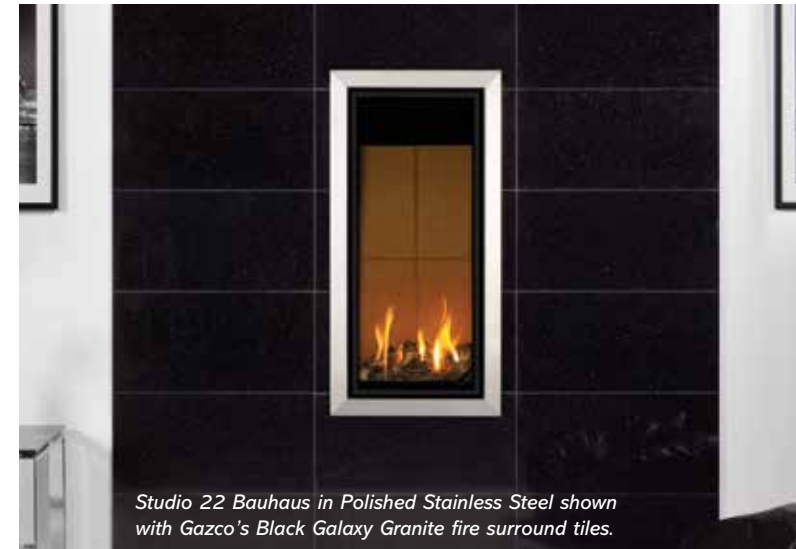

Studio 22 Bauhaus in Polished Stainless Steel shown with Gazco's Black Galaxy Granite fire surround tiles.

The stunning Glass Fronted Studio 22 offers the option of adding portrait styling to your living space. Specifically designed to add vertical presence, this portrait fire will instantly become a focal point in any interior, whether installed either as a frameless Edge or with one of the many frame options available.

All Studio 22 fires feature our stunning log-effect fuel bed and also incorporate a special heat-retaining lining, adding to the fire's performance and energy efficiency. It incorporates Studio features such as the Programmable Thermostatic remote control, allowing you to operate everything from ignition to heat output at just the push of a button,

Finishes

Anthracite (Bauhaus & Profil)
Polished Stainless Steel (Bauhaus & Profil)
Graphite (Steel, Verve & Expression)
Natural Limestone (Sorrento)

Graphite Granite (Sorrento)
Metallic Red (Steel, Bauhaus, Profil, Verve & Expression)
Metallic Bronze (Steel, Bauhaus, Profil, Verve & Expression)
Ivory (Steel, Bauhaus, Profil, Verve & Expression)

Colour options shown on pages 48-49

Fire Choice

Studio 22 – Glass Fronted, Balanced Flue



Efficiency

78%

Heat Output

5.85kW

Dimensions ^Δ w x h (mm)

Edge	423 x 1029
Profil	510 x 1036
Bauhaus	524 x 1050
Steel	675 x 1320
Expression	614 x 1140
Verve	676 x 1320
Sorrento	914 x 1290

Fuel Bed

Logs

Lining

Vermiculite

Command Controls

Programmable

Thermostatic remote



^Δ Dimensions given are those overall visible upon installation. Efficiency figures are based upon the maximum heat output achieved in the options available. For more detailed technical information, including firebox dimensions and installation requirements, please see page 122. 'Frameless Edge' refers to added exterior frames. All Glass Fronted Studio fires have an additional 27mm inner frame that secures the glass window in place. For Edge installation you will require a kit as shown on page 121.





Studio 22 (continued)

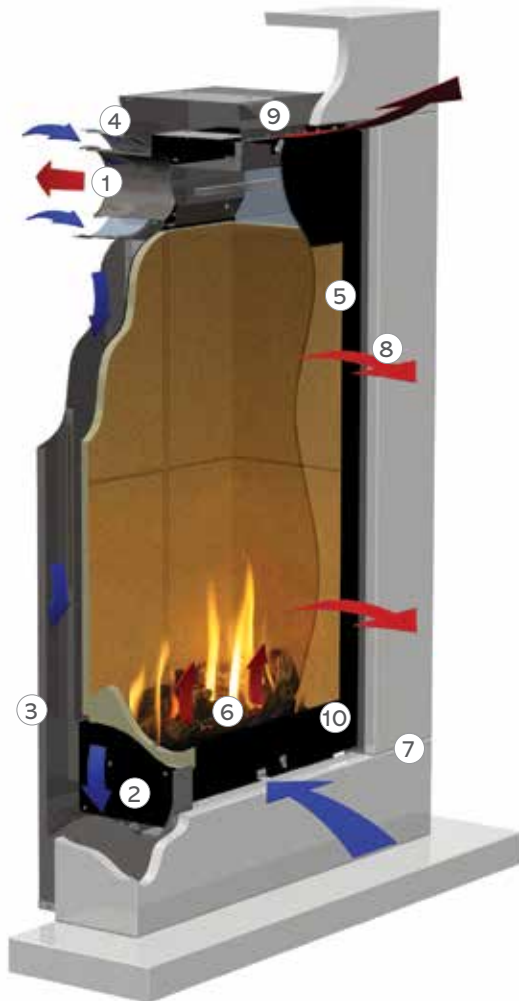

Key Features

1. Balanced Flue connection
2. Shallow firebox depth
3. Flat wall installation (*rear exit only when combined with Sorrento frame*)
4. Top or rear flue options for location flexibility
5. Glass Fronted
6. Realistic log-effect fire
7. Choice of frame styles
8. Convected and radiant heat
9. Convected heat system outlet
10. Easy maintenance access
11. Programmable Thermostatic remote control included*
12. External battery holder for ease of battery change*
13. Optional mains adaptor*



* Not illustrated

With six model choices available, from the 'hole in the wall' Edge, with its frameless design†, to the visually impressive Sorrento stone surround in Graphite Granite, (shown above right) the Studio 22 offers many style choices to greatly expand your interior possibilities.

Another advantage of the Studio 22 when combined with the Sorrento stone surround is its ease of installation. The Sorrento surround reduces the depth of the installation to only one course of brickwork, thus reducing installation costs.

† Frameless refers to added exterior frames, Studio 22 fires have an additional 27mm inner frame that secures the glass window in place.



Studio Pienza & Firenze



Pienza detail



Studio 1 Pienza, Open Fronted with White Stone fuel bed

The Firenze and Pienza stone frames offer two stylish natural options to complement your Studio fire. This range has been created to add maximum visual impact and it blends the subtle textures and delicate tones of natural stone with the very latest in fireplace design.

Available in a choice of two sizes of Open Fronted Studio, both featuring a reflective stainless front plate and optional polished black granite interior. Simply operated by the innovative remote, you can now sit back, relax and control everything at the touch of a button. Style has never been so effortless!

Stone Choice

Firenze - Granite*
Pienza - Limestone*

Fuel Beds

White Stones
Glass Beads - Red, Clear or Black
(White stone upgrade)

Command Control

Standard remote



Linings

Black Steel (Standard)
Polished Granite (Upgrade)

Fire Choices (see pages 8 - 15)

	Efficiency	Heat Output	Dimensions ^Δ w x h (mm)
Studio 1 – Open Fronted, Conventional Flue 	25%	1.72kW	1200 x 600
Studio 2 – Open Fronted, Conventional Flue	25%	2.30kW	1500 x 600

^Δ Dimensions given are those overall visible upon installation. Efficiency figures are based upon the maximum heat output achieved in the options available. For more detailed technical information, including firebox dimensions, installation and flue gather requirements, along with information on installing televisions above Open Studio fires, please see pages 118-121.

*Stone is a natural material and therefore each fire will have unique variations in the shading and patterning that occur in the stone used.

Studio Slimline

This new slimmer depth fire has been created to allow an easier, quicker and more cost effective installation option for many homes, whilst still retaining all the unmistakable characteristics of the Gazco Studio range.



*Studio 1 Slimline Verve in Graphite, Glass Fronted
with Log-effect fuel bed and Brick-effect Lining*

The Slimline Benefits



The Glass Fronted Studio 1 Slimline has been specifically developed to allow the highly desirable aesthetics of the landscape Studio fires to be achieved in a wider variety of homes by simply recessing into the internal leaf of a cavity wall. It also comes complete with a dedicated rear exit balanced flue termination kit for easy installation - see page 122 for further information.

Although compact in design, this highly efficient fire has a heat output of up to 4.25kW and comes complete with Gazco's very latest Programmable Thermostatic remote control so you can operate everything from ignition to extinguish with total ease.

Key Features

1. Shallow firebox depth of just 155mm
2. Balanced Flue connection
3. Choice of linings
4. Choice of contemporary or realistic fuel effects
5. Choice of frame styles
6. Convected and radiant heat
7. Convected heat system outlet
8. Programmable Thermostatic remote control
9. Rear exit Balanced Flue Termination Kit included
10. External battery holder for ease of battery change*
11. Optional mains adaptor*

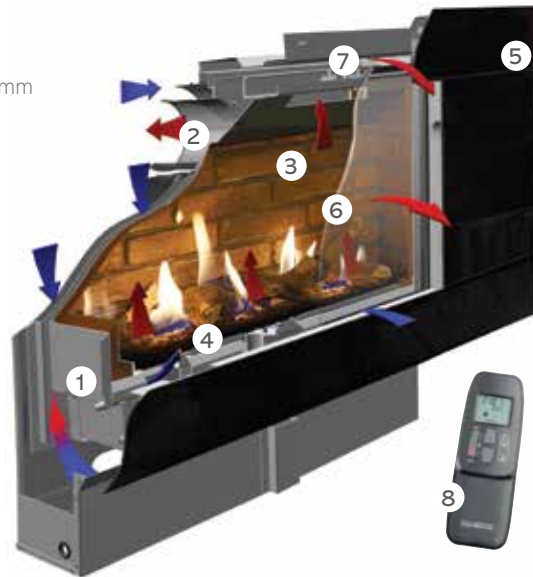

* Not Illustrated

Slimline Frame Options

The Studio 1 Slimline can be installed as a minimalist Edge model with its frameless design or, for added impact, it can be styled with one of the many high quality frames available, a selection of which are shown on these pages and overleaf. However for a complete frame style reference, please see pages 16-17.

Fuel Effects and Lining Options

To further extend your options for personalisation, there is a choice of three linings and three fuel effects available for the Studio 1 Slimline. Each of the lining choices: contemporary vermiculite, timeless black reeded or classic brick effect can be paired with either realistic log or contemporary white stone fuel effects with the additional option to upgrade your white stones to one of three glass bead effects.



Vermiculite Lining



Brick-effect Lining



Black Reeded Lining

With each combination offering a significantly different appearance to the fire, you can be sure to select the perfect combination of fuel effect, lining and frame style to suit your interior decor.



Studio 1 Slimline, Glass Fronted with Glass frame, White Stone fuel bed & Black Reeded Lining. Inset: Upgradeable Red, Black & Clear Glass Bead fuel effects.

Studio Slimline



Studio 1 Slimline Edge, Glass Fronted with Log-effect fuel bed and Black Reeded lining



Studio Slimline Profil in Anthracite shown with Log-effect fuel bed and Brick-effect lining



The Studio 1 Slimline offers all the distinctive hallmarks that are synonymous with the Gazco Studio range, with the added benefit of a slimmer firebox designed specifically for simple cavity wall installation.

The Slimline has a wealth of styling options available including a wide frame selection, a choice of three lining options and the option to select from a choice of fuel effects, each allowing you to tailor your fire to your desires and provide a perfect warming heart for your home.

Whether you opt for the modern appeal of the white stone option, the mirror-like qualities of the glass bead fuel effects or for the ultimate 'real fire' look of the log-effect option with its hand-painted detailing and glowing ember bed, your Studio Slimline is a highly efficient fire designed for low running costs in a wide range of homes – and you don't even need a chimney!

Finishes

- | | |
|---|--|
| Anthracite (Bauhaus & Profil) | Metallic Red (Steel 2, Bauhaus, Profil, Verve & Expression) |
| Polished Stainless Steel (Bauhaus & Profil) | Metallic Bronze (Steel 2, Bauhaus, Profil, Verve & Expression) |
| Graphite (Steel 2, Verve & Expression) | Ivory (Steel 2, Bauhaus, Profil, Verve & Expression) |
| Black Glass (Glass) | |

Colour options shown on pages 48-49

Fire Choices

Studio 1 Slimline - Balanced Flue

Efficiency

82%

Heat Output

4.25kW

Fuel Beds

- Logs
- White Stones
- Glass Beads - Red, Clear or Black (White stone upgrade)

Linings

- Vermiculite
- Brick Effect
- Black Reeded

Command Controls

- Programmable
- Thermostatic remote



Dimensions [^] w x h (mm)

Edge	745 x 416
Profil	836 x 510
Bauhaus	850 x 524
Expression	940 x 614
Steel 2	1264 x 528
Verve	1264 x 528
Glass	1264 x 528

[^] Dimensions given are those overall visible upon installation. Efficiency figures are based upon the maximum heat output achieved in the options available. For more detailed technical information, including firebox dimensions and installation requirements, please see page 122



*Studio 1 Slimline Profil in Anthracite, Glass Fronted
with Log-effect fuel bed and Vermiculite Lining*



*Studio 1 Slimline Expression in Graphite,
Glass Fronted with Log-effect fuel bed
and Brick-effect Lining*

Studio Slimline (continued)



Studio 1 Slimline Steel 2 in Graphite, Glass Fronted with White Stone fuel bed and Black Reeded Lining



Studio 1 Slimline Bauhaus in Polished Stainless Steel, Glass Fronted with Log-effect fuel bed and Vermiculite Lining

Complete your Studio 1 Slimline with one of Gazco's smart frame options, each offering a distinctive and complementary look for your fire. The sleek Glass frame is finished in chic reflective black glass while the rest of the frame selection is available in a choice of striking colours and finishes. The minimal frameless look of the Edge draws the eye inwards to further emphasise the beautiful flames and glowing ember effects or you may prefer to create impact with the gently curving Verve frame. Whatever your choice, there is a frame to ensure your stylish new fire perfectly complements your home's interior decor.

For further fire and frame information, please refer to pages 38 - 40. For information on supplementary colour frame options, please see pages 48 - 49.

Studio Duplex

For a truly awe-inspiring focal point in your home, the high efficiency, double-sided Duplex fire offers the ultimate stylish solution to practical dual space heating.



The Duplex Benefits



The Gazco Studio range has long been appreciated for its widescreen flame picture, high efficiency output and broad selection of frame style choices. The new Glass Fronted Studio 2 Duplex has been introduced to allow these fabulous features along with a heat output of up to 7.9kW to be enjoyed from two rooms at once from the same fire. The Studio Duplex also includes a wonderfully realistic log-effect fuel bed with hand-finished detailing and a highly attractive glowing ember effect for the ultimate in real fire ambiance.

Key Features

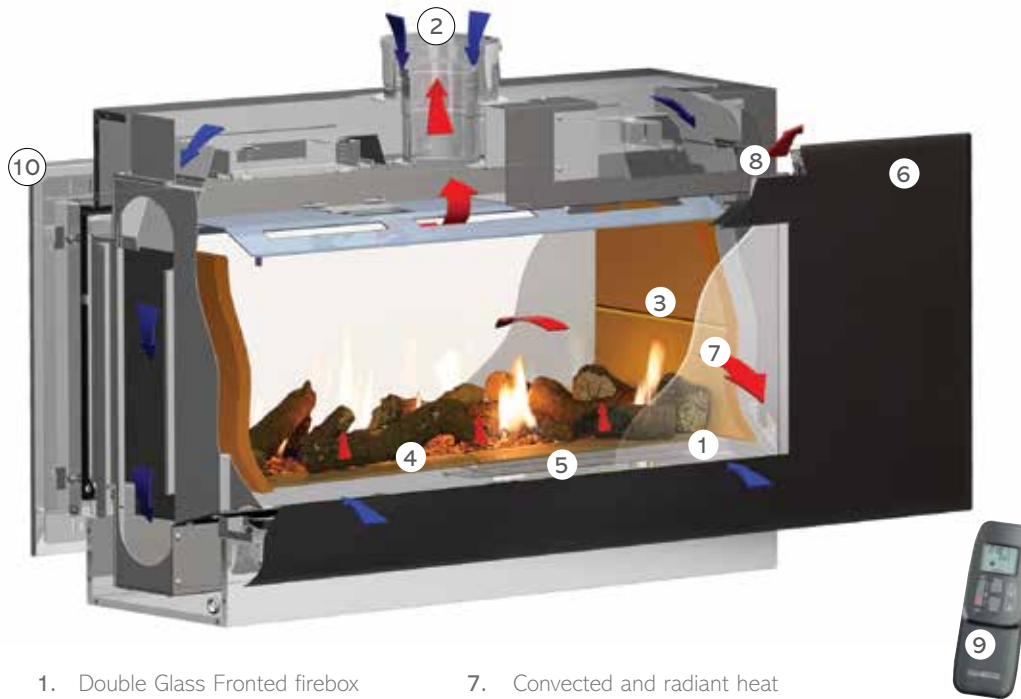

- | | |
|------------------------------------|---|
| 1. Double Glass Fronted firebox | 7. Convected and radiant heat |
| 2. Balanced Flue connection | 8. Convected heat system outlet |
| 3. Choice of linings | 9. Programmable Thermostatic remote control |
| 4. Realistic log-effect fire | 10. Dual styling options |
| 5. Realistic Glowing ember feature | 11. External battery holder for ease of battery change* |
| 6. Wide choice of frame styles | 12. Optional mains adaptor* |

*Not Illustrated

Lining Options



Vermiculite Lining



Black Reeded Lining

To further extend your options for personalisation, the Duplex offers a choice of linings, each providing a distinctly different look for your fire. The vermiculite linings complement the hand-painted logs and boost the light appeal of the glowing fire. The black reeded linings however, provide a striking and contrasting backdrop that really serves to display the beautiful flames to their fullest potential.

Duplex Frame Options

The Studio 2 Duplex has the benefit of dual styling possibilities, allowing you to select a different look for each side of the fire - offering double the impact in your home. Whether opting for a minimalist Edge look with its frameless design or choosing a Glass frame with its sparkling, reflective black glass, there are a selection of frame styles that will attract the eye and enhance your two interior spaces. A selection of the stylish frame choices are shown overleaf, however for a complete frame style reference, please see pages 16 - 17.

Studio Duplex



Studio 2 Duplex with Vermiculite lining and Profil frame in Anthracite



Studio 2 Duplex with Black Reeded lining shown as an Edge installation

One of the latest exciting additions to the Gazco Studio range is the Studio 2 Duplex - offering unrivalled flame pictures in two rooms at once! Available in the popular Studio 2 size, this dual space fire is a much desired solution in having the best of both worlds. With a wealth of frame options to choose from, the Studio 2 Duplex can be styled completely independently on either side to maximise the potential of your own decorative tastes.

To further enhance the many styling options, the Duplex offers the additional choice of two firebox linings; contemporary vermiculite or timeless black reeded - both of which offer a unique and distinctly different look for your Duplex fire. Sporting a stunning hand-painted, log-effect fuel bed complete with subtle glowing ember bed and giving a high efficiency rating of up to 82%, the Studio 2 Duplex not only provides an impressive visual focal point in two rooms, it also produces an impressive 7.9kW heat output.

Finishes

Anthracite (Bauhaus & Profil)	Metallic Red (Steel 2, Bauhaus, Profil, Verve & Expression)
Polished Stainless Steel (Bauhaus & Profil)	Metallic Bronze (Steel 2, Bauhaus, Profil, Verve & Expression)
Graphite (Steel 2, Verve & Expression)	Ivory (Steel 2, Bauhaus, Profil, Verve & Expression)
Black Glass (Glass)	

Fire Choices

	Efficiency	Heat Output
Studio 2 Duplex - Balanced Flue 	82%	7.9kW

Dimensions ^A w x h (mm)

Edge	945 x 416
Profil	1036 x 510
Bauhaus	1050 x 524
Expression	1140 x 614
Steel 2	1500 x 528
Verve	1500 x 528
Glass	1500 x 528

Fuel Bed

Logs

Linings

Vermiculite
Black Reeded

Command Controls

Programmable
Thermostatic remote



^A Dimensions given are those overall visible upon installation. Efficiency figures are based upon the maximum heat output achieved in the options available. For more detailed technical information, including firebox dimensions and installation requirements, please see page 123.

Colour options shown on pages 48 - 49



Studio 2 Duplex with Vermiculite lining and Bauhaus frame in Anthracite

Coloured Frame Options



Studio 22 Steel in Metallic Red, Glass Fronted with Log-effect fuel bed and Vermiculite lining



Studio 2 Bauhaus in Metallic Bronze, Glass Fronted with Log-effect fuel bed and Vermiculite lining

For those that want to add a splash of colour to their living space, Gazco offer three vibrant colour options specifically designed to complement the stylish, contemporary form of many of our modern fire frames. Whether to enliven your living room or brighten your bedroom, the three striking colours are sure to catch the eye and bring the wow factor to your interior space.

There are three eye-catching colours to choose from: Metallic Red, Metallic Bronze and Ivory. Please use the product code for the relevant frame of your choice, with the following suffix for your chosen colour:

- Metallic Red (RD)
- Metallic Bronze (BZ)
- Ivory (IV)

For example: Studio 1 Open Fronted Profil in Metallic Red = 8710ANRD

In addition to the following fires, the Profil, Bauhaus, Steel 2, Expression and Verve frames are all available in our three supplementary colours for the Studio 22, Studio Slimline and Studio Duplex fires.

The colours shown on this page are available for the following fires and frames:

Studio Profil.....pages 20 - 21	Riva2 530 & 670 Evoke Glass.....pages 86 - 87
Studio Bauhaus.....pages 22 - 23	Riva2 530 & 670 Evoke Steel.....pages 88 - 89
Studio Expression.....pages 24 - 25	Riva2 530 & 670 Vervepages 90 - 91
Studio Steel 2pages 26 - 27	Riva2 670 Verve XS.....pages 94 - 95
Studio Verve.....pages 30 - 31	
Eclipse Expression.....pages 56 - 57	
Eclipse Verve XS.....pages 58 - 59	
Riva2 500 & 750HL Evoke Glass.....pages 70 - 71	
Riva2 500 & 750HL Evoke Steel.....pages 72 - 73	
Riva2 500 & 750HL Verve XS.....pages 74 - 75	



Studio 2 Profil in Ivory, Glass Fronted with Log-effect fuel bed and Vermiculite lining



Riva Vision Large gas stove with Log-effect fuel bed and Vermiculite lining

Riva Vision Gas Stoves



Riva Vision Large gas stove with White Stone fuel bed on Riva 140 low bench



Riva Vision Small gas stove with Log-effect fuel bed



Riva Vision Medium gas stove with Log-effect fuel bed with gloss black flue pipe

Sporting an eye-catching glass fronted door and integral glass plinth, the high quality Gas Riva Vision is a sparkling addition to the Gazco range. Comprising four sizes, Small, Midi, Medium and Large, the Riva Vision stoves are complemented by a highly realistic log-effect fuel bed with the additional contemporary white stone or glass bead options available for the Large model. There are versions for both conventional and balanced flue installations, and various control options that can give you complete control, allowing full operation from ignition to extinguish, all from the comfort of your sofa.

To further increase your interior design possibilities, why not also opt for a contemporary stove bench or black gloss flue pipe (conventional flue only) - the perfect complement to these stylish stoves.

The Large log-effect model is also offered with a choice of either Vermiculite or Black Reeded linings.

Finish

Black Glass

Fuel Beds

Logs
White Stones*
Glass Beads - Red,
Clear or Black‡

Linings

Vermiculite (Small, Midi, Medium & Large - Logs)
Black Reeded (Large - Logs)
Black Enamel (Large - White Stones or Glass Beads)

Command Controls

Riva Vision Small, Midi & Medium
Manual, Standard Upgradeable remote or
Programmable Thermostatic Upgradeable remote.
Riva Vision Large:
Programmable Thermostatic remote



* White Stones and Glass Beads available for the Riva Vision Large only

‡ Glass Beads are available as an upgrade to White Stone models



For complete product and technical information, please see the Gazco Gas & Electric Stoves brochure, alternatively you can scan this QR code or visit www.gazco.com



Eclipse Fires

The all-new Eclipse 100 offers state-of-the-art features, beautiful design and cutting edge technology which combine to create the ultimate ambiance in your home. With an impressive heat output complemented by a choice of frames and lining options, this high efficiency fire will instantly add contemporary elegance to any home.



Fabulous Frames & Flames

The very latest fire to adorn the Gazco range, the Eclipse 100 brings with it a series of new technological advancements that combine to create a high efficiency fire with a truly awe-inspiring flame picture. The generous firebox offers a highly realistic flame picture that flows through a hand-painted, ultra realistic log-effect fuel bed accentuated by a mesmerising glowing ember bed. The Eclipse also presents a choice of three sophisticated frames and a 'hole-in-the-wall' frameless Edge design which ensures there is a modern, contemporary style choice to suit all interiors.

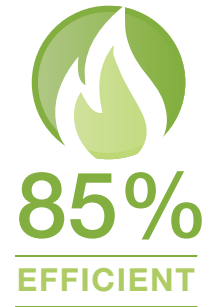

Convenient Control

The Eclipse 100 also comes complete with a Programmable Thermostatic remote control as standard. Allowing you full control over your fire, the handset operates everything from ignition to extinguish as well as integrating a programmable timer, temperature control and Gazco's convection fan air system from the touch of a button. The advanced dual-burner system also allows you to set your perfect atmosphere by selecting to use one or two burners, giving you total control over flame height and heat output.



Luxury Linings

Further extending its appeal and style options, the Eclipse 100 has two attractive lining choices - classic Black Reeded and smart Ledgestone Effect. The Black Reeded lining offers a striking contrast to the flickering flame, whilst the Ledgestone Effect, with its textured profile finish, brings a brighter, natural alternative that adds interest even when the fire is off. Each lining enhances the overall setting of your new Eclipse fire whilst offering their own unique and distinctive finish.



Black Reeded Lining



Ledgestone Effect Lining





Eclipse Edge



Eclipse 100 Edge with Ledgestone Effect Lining

Installed as a frameless 'Edge', the Eclipse 100 can create a breathtaking hole-in-the-wall focal point that lets the enticing flame picture take centre stage - perfect for any interior. With the tall, eager flames dancing through the wonderfully realistic log-effect fuel bed, the Eclipse 100 Edge is a statement in itself.

Fuel Bed
Logs

Linings
Black Reeded
Ledgestone Effect

Command Control
Programmable Thermostatic remote



Fire Choice

Efficiency

Heat Output

Dimensions^Δ w x h (mm)

Eclipse 100 Edge, Balanced Flue		85%	9.35kW	1067 x 451
---------------------------------	--	-----	--------	------------

^Δ Dimensions given are those overall visible upon installation. Efficiency figures are based upon the maximum heat output achieved in the options available. For more detailed technical information, including firebox dimensions and installation requirements, please see page 123.

See additional image on page 52.

Eclipse Expression



Eclipse 100 Expression in Graphite with Black Reeded Lining. Installed on a ceramic tiled wall

The Eclipse Expression is a versatile frame that can fit in with a wide spectrum of interior styles. Available in Graphite or a choice of three stunning metallic colour options, the deep profile of the Expression frame has a smooth, geometric design which perfectly captures the large flame picture and realistic log-effect fuel bed. A perfect finish to an already incredible focal point.

Finishes

Graphite
Metallic Red
Metallic Bronze
Ivory

*Colour options shown
on pages 48 - 49*

Fuel Bed

Logs

Linings

Black Reeded
Ledgestone Effect

Command Control

Programmable
Thermostatic remote



Fire Choice

Efficiency

Heat Output

Dimensions^Δ w x h x d (mm)

Eclipse 100 Expression, Balanced Flue



85%

9.35kW

1290 x 650 x 40

Δ Dimensions given are those overall visible upon installation. Efficiency figures are based upon the maximum heat output achieved in the options available. For more detailed technical information, including firebox dimensions and installation requirements, please see page 123.

See additional image on page 131.



Eclipse 100 Expression in Graphite with Ledgerstone Lining



*Eclipse 100 Verve XS in Graphite
with Ledgestone Effect Lining*

Eclipse Verve XS



Eclipse 100 Verve XS in Metallic Red with Black Reeded Lining

For a slightly bolder style choice, the Eclipse Verve XS has a subtly curving 3D form which can be appreciated from all angles. Available in sophisticated Graphite or a choice of striking supplementary colours, the Verve XS really adds impact and accentuates the impressive Eclipse in your living room.

Finishes

Graphite
Metallic Red
Metallic Bronze
Ivory

*Colour options shown
on pages 48 - 49*

Fuel Bed

Logs

Linings

Black Reeded
Ledgestone Effect

Command Control

Programmable
Thermostatic remote



Fire Choice

Eclipse 100 Verve XS, Balanced Flue



Efficiency

85%

Heat Output

9.35kW

Dimensions^Δ w x h x d (mm)

1435 x 693 x 58

^Δ Dimensions given are those overall visible upon installation. Efficiency figures are based upon the maximum heat output achieved in the options available. For more detailed technical information, including firebox dimensions and installation requirements, please see page 123.

Eclipse Icon XS



Eclipse 100 Icon XS with LedgeStone Effect Lining

A truly magnificent, iconic design - the Eclipse Icon XS really delivers in style with its lavish black glass frame. Surrounding the eye-catching flame and fuel-bed, the highly reflective black glass surfaces eschew any nod to traditional styling and instead places the emphasis purely on contemporary designer chic.

Finishes

Black Glass

Fuel Bed

Logs

Linings

Black Reeded
LedgeStone Effect

Command Control

Programmable
Thermostatic remote



Fire Choice

Efficiency

Heat Output

Dimensions^A w x h x d (mm)

Eclipse 100 Icon XS, Balanced Flue		85%	9.35kW	1386 x 754 x 26
------------------------------------	--	-----	--------	-----------------

^A Dimensions given are those overall visible upon installation. Efficiency figures are based upon the maximum heat output achieved in the options available. For more detailed technical information, including firebox dimensions and installation requirements, please see page 123.



Riva2 Fires

Our prestigious range of Riva2 fires combines stylish aesthetics with the high levels of performance you would expect from Gazco. Choose from a selection of portrait and landscape fires along with a wide variety of styling options to create the perfect Riva2 for your home.



*Riva2 670 Designio2 Steel in Graphite with Vermiculite lining
shown with Rovere Wood Effect Fireplace Surround Tiles*

Riva2 500 & 750HL



Riva2 500	Riva2 750HL
-----------	-------------

Riva2 530 & 670



Riva2 530	Riva2 670
-----------	-----------

Riva2 800 & 1050



Riva2 800	Riva2 1050
-----------	------------

Choice of Fuel Bed:

Realistic Logs	✓	✓
----------------	---	---

Choice of Linings:

Brick Effect	✓	✓
Vermiculite	✓	X
Fluted Vermiculite	X	✓
Black Reeded	✓	✓

Installation Type:

Hearth Mounted Installation	✓	✓
Wall Installation	✓	✓

Key Features:

Timer and Thermostat Programmable Remote	✓	✓
Dual Burner Control	X	X
Glass Fronted High Efficiency	✓	✓
Natural Gas or LPG	✓	✓
Wide Selection of Frames	✓	✓
Frameless 'Edge' Option	✓	✓
Conventional Flue ODS safety device*	✓	✓
Balanced Flue Firebox Relief Venting System ^Δ	✓	n/a
Additional air vent required	X	✓
Conventional Flue	✓	✓
Balanced Flue	✓	X
Maximum Heat Output	4.80kW	7.00kW
Maximum Efficiency	82%	80%

✓	✓
---	---

✓	✓
✓	✓
X	X
✓	✓

✓	✓
✓	✓

✓	✓
X	X
✓	✓
✓	✓
✓	✓
✓	✓
✓	✓
✓	✓
X	X
✓	✓
✓	✓
5.40kW	5.60kW
82%	82%

✓	✓
---	---

X	X
✓	✓
X	X
✓	✓

✓	✓
✓	✓

✓	✓
✓	✓
✓	✓
✓	✓
✓	✓
✓	✓
n/a	n/a
✓	✓
X	X
X ⁰	X ⁰
✓	✓
7.98kW	7.98kW
84%	84%

Riva2 500 & 750HL (pages 66 - 79)

Specifically proportioned to fit a standard 22" and 36" wide British fireplace, offering you greater opportunity to introduce a stunning gas fire into your home with complete ease of installation.

Riva2 530 & 670 (pages 80 - 95)

Offering you extensive and exciting options to help you create the perfect look for your home and taste, both the portrait 530 and the landscape 670 have an impressive heat output of up to 5.6kW, fully operated via a Programmable Thermostatic remote.

Riva2 800 & 1050 (pages 96 - 103)

These impressive fires have been developed with a new dual-burner engine that offers a greater operational range, allowing you to select the heat output and flame visual to really suit your mood. There are many styling options available, from our classical stone mantels to the more contemporary frameless hole-in-the-wall look Edge.

Riva2 Stone Mantels (pages 104 - 111)

A stunning collection of timeless stone mantels, each one crafted in your choice of Natural Limestone or Antique White Marble, the perfect complement to many of the Riva2 fires and the ideal way to add a more traditional fireplace setting into your home.

* ODS (Oxygen Depletion Sensor) - This Conventional Flue safety feature will shut off the gas supply to the burner in the event of a reduction to oxygen levels in the room. ^Δ All Gazco Balanced Flue fires have relief vents in the firebox ensuring compliance with EN 613:2001 for delayed ignition safety standards ⁰ The Riva2 800 & 1050 can be installed into a conventional chimney by using the optional Riva2 Renovation Kit.

Riva2 Styling Options

There are a wealth of frame choices available to perfectly complement your Riva2 fire, outlined on these pages and shown in detail throughout the brochure. Each one of these frames offers a unique styling possibility and is crafted from the very finest materials.

Whether your tastes lie with the contemporary or the traditional, you can find a Riva2 frame to suit your interior. Options include a stunning, frameless 'hole in the wall' look, sleek glass and steel finishes, striking colour options and a wealth of hand-crafted stone mantels; ensuring that whatever your style preference, there is a Riva2 fire for you.

Frame	Riva2 500	Riva2 750HL	Riva2 530	Riva2 670	Riva2 800	Riva2 1050
Edge	✓	✓	✗	✗	✓	✓
Icon XS	✓	✓	✗	✗	✓	✓
Ellingham	✓	✗	✓	✓	✗	✗
Verve XS	✓	✓	✗	✓	✗	✗
Verve	✗	✗	✓	✓	✗	✗
Evoke Steel	✓	✓	✓	✓	✗	✗
Evoke Glass	✓	✓	✓	✓	✗	✗
Designio2 Steel	✗	✗	✓	✓	✗	✗
Designio2 Glass	✗	✗	✓	✓	✗	✗
Sorrento	✗	✗	✗	✗	✓	✓
Stone Mantels	✓*	✓*	✓*	✗	✓*	✗

*Requires additional slip sets or back panels. The Riva2 750HL and 800 slip sets are available from Gazco. Bespoke sourcing will be required for other fires.

Sorrento



Graphite Granite or Natural Limestone

Stone Mantels - see pages 104 - 111



The Riva2 500, 530, 750HL & 800 are versatile fires that can be installed into both contemporary and more traditional interiors. Gazco's collection of six high quality stone mantels and hearths, with additional slip sets or backing panels, will complement these fires to ensure a grand finish and a timeless fireplace for your home.

Edge (Frameless)



Icon XS



Black Glass

Ellingham



Matt Black Cast Iron

Verve XS



Graphite



Evoke Steel



Graphite front and rear



Evoke Glass (Black Glass)



Black Glass front and Graphite rear

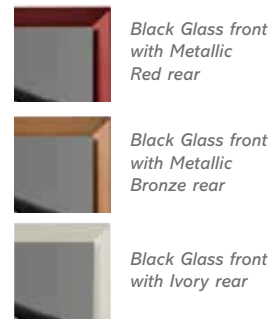

Evoke Glass (White Glass)



White Glass front and Graphite rear

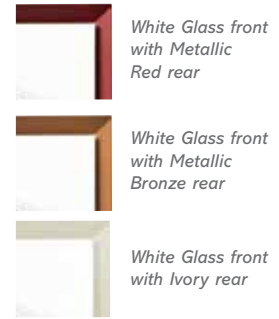

Designio2 Steel



Graphite



Iridium

Designio2 Glass



Black Glass

Verve



Graphite



Riva2 500 & 750HL

Thoughtfully designed to fit into standard 22" and 36" British fireplace openings, the Riva2 500 and the larger Riva2 750HL usher in a new era of gas fires. With their highly realistic log effect fuel beds complemented by a wide choice of striking frames, mantels and lining options, these outstanding fires can be perfectly tailored to your home's décor.



Riva2 500

Offering up to 4.8kW of high efficiency heat output, the Riva2 500 will provide cosy warmth for those cold winter evenings as well as the ambiance of a highly realistic log-effect fire with glowing ember bed. The Riva2 500 also comes with a Programmable Thermostatic remote to give you complete control over the fire from your sofa, for the ultimate in convenience and relaxation!

Riva2 750HL

The Riva2 750HL provides up to 7kW of heat, making it ideal for heating larger spaces efficiently, all fully controlled with incredible ease with the Programmable Thermostatic remote control included. Designed to fit into a standard 36" chimney opening, the Riva2 750HL allows homeowners to really make the most of their existing fireplace.

A wide range of frame styling options also allow the 750HL to make a true designer statement further up the wall.

Lining Options

To enhance your styling possibilities and ensure you can achieve a look that will best suit you and your home, Gazco has developed several lining options, each providing an entirely different aesthetic for the stunning log-effect fire. Opt for the classic brick effect; the glamorous black reeded lining or the light and contemporary vermiculite which also includes an attractive fluting detail on the 750HL models.



Brick Effect*
Riva2 500 & 750 HL



Black Reeded
Riva2 500 & 750 HL



Vermiculite
Riva2 500 only



Fluted Vermiculite
Riva2 750HL only

*Close up shown is of Riva2 500 Brick Effect. Riva2 750HL Brick Effect close up is shown on pages 74.



Riva2 750HL Icon XS with Black Reeded lining

Frame Options (see pages 64 - 65)

Choose from the contemporary styling of the 'Edge' with its clean, frameless design for that 'hole in the wall' look or alternatively opt for one of Gazco's distinctive frames to extend your styling possibilities. Ranging from the shining black glass of the Icon XS, to the subtle curves of the Verve XS, each frame is designed to create a real presence in your home and to complement your own individual tastes.

Remote Control

Both the Riva2 500 & Riva2 750HL come with a Programmable Thermostatic remote control, sporting a number of impressive settings; you can set your fire to thermostatically maintain a specific room temperature of your choosing, or you can programme your fire to a daily or weekly timer schedule for the ultimate in ease and convenience.





Riva2 500 & 750HL Edge



Riva2 750HL Edge with Brick Effect lining





Riva2 500 Edge with Black Reeded lining

The frameless aesthetic of the Riva2 500 & 750HL Edge allows you to create a chic, minimalist look whilst simultaneously bringing a focus to the beautiful flames of these highly efficient gas fires.

The simple, clean lines of a 'hole in the wall' fire can be further enhanced by creating a feature wall using Gazco's carefully selected range of fireplace tile surround packages as shown on page 116. This contemporary collection of porcelain and natural stone tiles are the perfect complement to the modern aesthetics of the Edge.

For a more traditional look, the Edge models can also be paired with one of Gazco's elegant classic stone mantels, see pages 104 - 111 for details.

Fire Choices

Fire Choices	Efficiency	Heat Output	Dimensions ^A w x h (mm)
Riva2 500 - Conventional Flue 	75%	4.80kW	550 x 388
Riva2 500 - Balanced Flue 	82%	4.80kW	550 x 388
Riva2 750HL - Conventional Flue	80%	7.00kW	801 x 711

^A Dimensions given are those overall visible upon installation. Efficiency figures are based upon the maximum heat output achieved in the options available. For more detailed technical information, including firebox dimensions and installation requirements, please see pages 124-125.

Fuel Bed

Logs

Linings

Vermiculite (500)
Fluted Vermiculite (750HL)
Brick Effect
Black Reeded

Command Controls

Programmable
Thermostatic remote



The Riva2 500 & 750HL Edge models can be combined with a choice of Gazco's high quality stone mantels - see pages 104 - 111 for details.

Riva2 500 & 750HL Evoke Glass



Riva2 750HL Evoke Glass with Black Glass front and Graphite rear, with Black Reeded lining



Riva2 500 Evoke Glass with Black Glass front and Metallic Bronze rear, with Vermiculite lining

The Evoke Glass combines a layer of stunning reflective glass with a sleek, steel background to create a sophisticated, contemporary frame. Available with a glossy black or white glass front, the steel rear section can be finished in Graphite or one of the three additional colours to create greater contrast.

With three stylish lining options, the Evoke Glass allows you to match your fire to your interior tastes for a truly bespoke finish.

Front Finishes

Black Glass
White Glass

Rear Finishes

Graphite
Metallic Red
Metallic Bronze
Ivory

Linings

Vermiculite (500)
Fluted Vermiculite (750HL)
Brick Effect
Black Reeded

Fuel Bed

Logs

Command Controls

Programmable
Thermostatic remote



Colour finishes shown on pages 48 - 49

Fire Choices

Efficiency

Heat Output

Dimensions^Δ w x h x d (mm)

Riva2 500 - Conventional Flue		75%	4.80kW	869 x 710 x 40
Riva2 500 - Balanced Flue		82%	4.80kW	869 x 710 x 40
Riva2 750HL - Conventional Flue		80%	7.00kW	1117 x 1034 x 42

^Δ Dimensions given are those overall visible upon installation. Efficiency figures are based upon the maximum heat output achieved in the options available. For more detailed technical information, including firebox dimensions and installation requirements, please see pages 124-125.

Additional image of the Riva2 500 Evoke Glass is shown on page 5.

*Riva2 500 Evoke Glass with White Glass
front and Graphite rear, with Brick Effect lining*





Riva2 750HL Evoke Steel with Graphite front and rear, with Fluted Vermiculite lining

Riva2 500 & 750HL Evoke Steel



Riva2 500 Evoke Steel with Graphite front and rear, with Black Reeded lining



Riva2 500 Evoke Steel with Metallic Red front and Graphite rear, with Brick-effect lining

Focusing purely on sharp, strong definition, the Evoke Steel is a beautiful two-part design with a graphite back that boldly frames the complementing graphite front. You can increase your styling options even further with three vibrant colour choices for the front: Metallic Red, Metallic Bronze or Ivory. These exciting colour options, matched with the graphite rear, produce an eye-catching look that is sure to provide a striking focal point in your home.

Front Finishes

- Graphite
- Metallic Red
- Metallic Bronze
- Ivory

Rear Finishes

- Graphite

Linings

- Vermiculite (500)
- Fluted Vermiculite (750HL)
- Brick Effect
- Black Reeded

Fuel Bed

- Logs

Command Controls

- Programmable
- Thermostatic remote



Colour finishes shown on pages 48 - 49

Fire Choices	Efficiency	Heat Output	Dimensions ^A w x h x d (mm)
Riva2 500 - Conventional Flue	75%	4.80kW	869 x 710 x 40
Riva2 500 - Balanced Flue	82%	4.80kW	869 x 710 x 40
Riva2 750HL - Conventional Flue	80%	7.00kW	1117 x 1034 x 42

^A Dimensions given are those overall visible upon installation. Efficiency figures are based upon the maximum heat output achieved in the options available. For more detailed technical information, including firebox dimensions and installation requirements, please see pages 124-125.

Riva2 500 & 750HL Verve XS



Riva2 750HL Verve XS in Graphite with Black Reeded lining.



Riva2 500 Verve XS in Ivory with Brick-effect lining



Riva2 750HL Brick-effect lining

A contemporary frame with unmistakable flair, the Verve XS, with its horizontal curve and smart graphite finish, forms the perfect contemporary counterbalance to the traditional aesthetics of these highly realistic log-effect fires.

Your Riva2 Verve XS can be tailored to your own particular preference by choosing from one of three distinctively different fire linings in chic brick effect, light vermiculite or smart black reeded. You can further customise your fire by choosing one of the three additional colour options for your frame; Metallic Red, Metallic Bronze or Ivory.

Colour Choice

Graphite
Metallic Red
Metallic Bronze
Ivory

Linings

Vermiculite (500)
Fluted Vermiculite (750HL)
Brick Effect
Black Reeded

Fuel Bed

Logs

Command Controls

Programmable
Thermostatic remote



Colour finishes shown on pages 48 - 49

Fire Choices

Efficiency

Heat Output

Dimensions^A w x h x d (mm)

Riva2 500 - Conventional Flue		75%	4.80kW	890 x 621 x 57
Riva2 500 - Balanced Flue		82%	4.80kW	890 x 621 x 57
Riva2 750HL - Conventional Flue		80%	7.00kW	1202 x 1005 x 54

^A Dimensions given are those overall visible upon installation. Efficiency figures are based upon the maximum heat output achieved in the options available. For more detailed technical information, including firebox dimensions and installation requirements, please see pages 124-125.

Riva2 500 & 750HL Icon XS



Riva2 750HL Icon XS with Black Reeded lining



Riva2 500 Icon XS with Brick-effect lining

A frame with real impact, the Icon XS makes a bold statement with its sleek, black reflective surfaces and clean, geometric design. At home in both modern and more traditional interiors, the Icon XS adds a touch of grandeur to your living space and enhances the stunning visuals of your Riva2 fire.

You can tailor your fire by selecting from one of our three lining choices, each offering a different setting in which to display the beautiful flames and the warming ambiance conjured by the hand-finished logs.

Finish

Black Glass

Linings

Vermiculite (500)
Fluted Vermiculite (750HL)
Brick Effect
Black Reeded

Fuel Bed

Logs

Command Controls

Programmable
Thermostatic remote



Fire Choices

Efficiency

Heat Output

Dimensions^Δ w x h x d (mm)

Riva2 500 - Conventional Flue		75%	4.80kW	945 x 784 x 17
Riva2 500 - Balanced Flue		82%	4.80kW	945 x 784 x 17
Riva2 750HL - Conventional Flue		80%	7.00kW	1089 x 1015 x 17

^Δ Dimensions given are those overall visible upon installation. Efficiency figures are based upon the maximum heat output achieved in the options available. For more detailed technical information, including firebox dimensions and installation requirements, please see pages 124-125.



Riva2 500 Icon XS with Vermiculite Lining shown with Gazco's Pretoria Anthracite Polished and Durban White Matt fireplace surround tiles



Riva2 500 Ellingham



Riva2 500 Ellingham with Black Reeded lining

Crafted from cast iron, the Ellingham front is a surround option designed for hearth mounted installations of the Riva2 500.

With cast detailing, the Ellingham adds a touch of grace and elegance to Gazco's range of smaller, but high efficiency, glass fronted Riva2 fires. Although classic in style, the Ellingham will sit equally at home in both modern and traditionally styled interiors, with a matt black finish to offset the highly realistic log effect and choice of either Brick effect, Vermiculite or Black Reeded lining options.

Finish
Matt Black Cast Iron

Linings
Vermiculite
Brick Effect
Black Reeded

Fuel Bed
Logs

Command Controls
Programmable
Thermostatic remote



Fire Choices		Efficiency	Heat Output	Dimensions ^A w x h x d (mm)
Riva2 500 - Conventional Flue		75%	4.80kW	885 x 678 x 75
Riva2 500 - Balanced Flue		82%	4.80kW	885 x 678 x 75

^A Dimensions given are those overall visible upon installation. Efficiency figures are based upon the maximum heat output achieved in the options available. For more detailed technical information, including firebox dimensions and installation requirements, please see pages 124-125.

Additional image of the Riva2 500 Ellingham is shown on page 124.



Riva2 530 & 670

The Riva2 530 and Riva2 670 are contemporary gas fires that are available with a stunning collection of contemporary and traditional frames and lining options, enabling you to create the perfect look for your home.

*Riva2 670 Evoke Steel with Metallic Red front,
Graphite rear and Brick-effect lining*

High Efficiency Gas Fires

With their glass-fronted design, Riva2 530 and 670 fires provide not only exceptional design, but also outstanding efficiencies of up to 82%. This high efficiency ensures that over 5kW of comforting heat is delivered into your living space, creating a wonderful warming ambiance.

Framing Options (see pages 64 - 65)

There is an extensive choice of frames available for the Riva2 530 and 670 fires and several come with a number of additional colour finishes to create your own individual look. Choose from the designer curves of the 3D Verve and Verve XS frames, the Evoke Glass or Evoke Steel with their stunning layered composition and wide range of styling possibilities, the subtle detailing of the sophisticated Designio2 Glass and Designio2 Steel or the Neo-Georgian inspired Ellingham with its high-quality cast iron details.

Lining Options

To create a truly bespoke look that is just right for you, there is a choice of three stylish linings, each designed to offer a different look for the outstandingly realistic log-effect fire.

Choose from the classic brick effect, chic vermiculite or the thoroughly smart black reeded lining, all of which form a unique complement to the attractive Riva2 530 and 670 fires.



Vermiculite Lining



Black Reeded Lining



Brick Effect Lining



Riva2 530 Designio2 Glass with Black Reeded lining, shown with Malmo mantel available from Stovax.

Simple Installation

The Riva2 530 and 670 are both compatible with our optional linerless flue kit. At just 0.5 metres long, this short piece of flexible, stainless steel flue pipe and debris deflector has been specifically designed to be slotted into your masonry chimney. This eliminates the need for the chimney to be fully lined and any associated labour, facilitating a simpler and more cost effective installation.

Remote Control

Supplied as standard with your Riva2 530 or 670 fire, this multi-function Programmable Thermostatic remote enables ignition, extinguish and flame control alongside advanced thermostatic and timer programming functions. Whether you decide to set a daily or weekly programme or simply prefer to maintain a desired room temperature, your gas fire can provide a warming welcome, every time you return home.





Riva2 530 Designio2 Glass with Brick-effect lining

Riva2 530 & 670 Designio2 Glass



Riva2 670 Designio2 Glass with Black Reeded lining



Riva2 530 Designio2 Glass with Vermiculite lining

The Designio2 Glass frame has smart, reflective black surfaces with subtle detailing and clean lines. It is a sophisticated front for both the portrait dimensions of the Riva2 530 and the landscape shape of the Riva2 670 and its simple, chic design will complement a wide array of interiors.

Combined with your choice of the three linings available in brick effect, vermiculite or black reeded, the Designio2 makes for a glamorous addition to your home.

The Riva2 530 and 670 are both compatible with our linerless flue kit for a simplified installation. Please see page 81 for further information. This stunning fire can also be hearth-mounted for installation into a traditional fireplace opening.

Finish
Black Glass

Linings
Vermiculite
Brick Effect
Black Reeded

Fuel Bed
Logs

Command Controls
Programmable
Thermostatic remote



An additional image is shown on page 81.

Fire Choices

Efficiency

Heat Output

Dimensions^Δ w x h x d (mm)

Riva2 530 - Conventional Flue		75%	5.1kW	608 x 704 x 40
Riva2 530 - Balanced Flue		82%	5.4kW	608 x 704 x 40
Riva2 670 - Conventional Flue		75%	5.1kW	735 x 569 x 40
Riva2 670 - Balanced Flue		82%	5.6kW	735 x 569 x 40

^Δ Dimensions given are those overall visible upon installation. Efficiency figures are based upon the maximum heat output achieved in the options available. For more detailed technical information, including firebox dimensions and installation requirements, please see pages 126-127



The Riva2 530 Designio2 Glass can be combined with a choice of Gazco's high quality stone mantels - see pages 104 - 111 for details.

Riva2 530 & 670 Designio2 Steel



Riva2 670 Designio2 Steel in Graphite with Vermiculite lining



Riva2 530 Designio2 Steel in Iridium with Black Reeded lining

The Designio2 Steel is a tasteful frame that has been thoughtfully shaped for the Riva2 530 and 670 and which sports a simple yet sophisticated design. Finished in a choice of stylish Graphite or smart Iridium, the Designio2 Steel offers you a complete focal point with a thoroughly contemporary and cutting edge look that will complement many interiors and decors.

The Riva2 530 and 670 are both compatible with our linerless flue kit for a simplified installation. Please see page 81 for further information.

Finishes

Graphite
Iridium

Linings

Vermiculite
Brick Effect
Black Reeded

Fuel Bed

Logs

Command Controls

Programmable
Thermostatic remote



Fire Choices	Efficiency	Heat Output	Dimensions ^Δ w x h x d (mm)
Riva2 530 - Conventional Flue	75%	5.1kW	608 x 704 x 38
Riva2 530 - Balanced Flue	82%	5.4kW	608 x 704 x 38
Riva2 670 - Conventional Flue	75%	5.1kW	735 x 569 x 38
Riva2 670 - Balanced Flue	82%	5.6kW	735 x 569 x 38

^Δ Dimensions given are those overall visible upon installation. Efficiency figures are based upon the maximum heat output achieved in the options available. For more detailed technical information, including firebox dimensions and installation requirements, please see pages 126-127



The Riva2 530 Designio2 Steel can be combined with a choice of Gazco's high quality stone mantels - see pages 104 - 111 for details.



Riva2 670 Designio2 Steel in Graphite with Brick-effect lining



Riva2 530 & 670 Evoke Glass



Riva2 670 Evoke Glass in Black Glass with Metallic Bronze rear and Black Reeded lining



Riva2 530 Evoke Glass in White Glass with Graphite rear and Brick-effect lining

The Evoke Glass is an eye-catching frame with two separate layers of stunning reflective glass and sophisticated steel combining to create a thoroughly stylish accompaniment to the portrait dimensions of the 530 and the landscape 670. Choose from shining black or white glass for the front of your frame, to complement the bevelled rear steel section in Graphite and with the additional choice of colour finishes from vibrant Metallic Red, Metallic Bronze and Ivory.

Furthermore with three chic lining options, the combination possibilities available with the Riva2 530 and 670 are numerous, enabling you to create a truly bespoke fire for your home.

Front Finishes

Black Glass
White Glass

Linings

Vermiculite
Brick Effect
Black Reeded

Rear Finishes

Graphite
Metallic Red
Metallic Bronze
Ivory

Fuel Bed

Logs

Command Controls

Programmable
Thermostatic remote



Colour finishes are shown on pages 48 - 49.

Fire Choices

Efficiency

Heat Output

Dimensions^Δ w x h x d (mm)

Riva2 530 - Conventional Flue		75%	5.1kW	795 x 752 x 40
Riva2 530 - Balanced Flue		82%	5.4kW	795 x 752 x 40
Riva2 670 - Conventional Flue		75%	5.1kW	920 x 622 x 40
Riva2 670 - Balanced Flue		82%	5.6kW	920 x 622 x 40

Δ Dimensions given are those overall visible upon installation. Efficiency figures are based upon the maximum heat output achieved in the options available. For more detailed technical information, including firebox dimensions and installation requirements, please see pages 126-127

The Riva2 530 and 670 are both compatible with our linerless flue kit for a simplified installation. Please see page 81 for further information.



Riva2 670 Evoke Steel with Graphite front and rear with Brick-effect lining

Riva2 530 & 670 Evoke Steel



Riva2 670 Evoke Steel with Ivory front, Graphite rear and Vermiculite lining



Riva2 530 Evoke Steel with Metallic Red front, Graphite rear and Black Reeded lining

The Evoke Steel is a stunning, two-part design that blends expertly into today's modern interiors. The front face of this frame comes in a stylish Graphite finish with the option for customisation in one of three exciting additional colour choices. The attractive bevelled rear is left in Graphite to perfectly complement the standard finish on the front or form a contrasting border to any of the bold colour choices. With Programmable Thermostatic remote control and high efficiency output, the Riva2 Evoke steel will be as impacting in its functionality as it is in its designer aesthetics.

Front Finishes

Graphite
Metallic Red
Metallic Bronze
Ivory

Rear Finishes

Graphite

Linings

Vermiculite
Brick Effect
Black Reeded

Fuel Bed

Logs

Command Controls

Programmable
Thermostatic remote



Also see image on page 80.

Colour options are shown on pages 48 - 49.

		Efficiency	Heat Output	Dimensions ^Δ w x h x d (mm)
Riva2 530 - Conventional Flue		75%	5.1kW	795 x 752 x 40
Riva2 530 - Balanced Flue		82%	5.4kW	795 x 752 x 40
Riva2 670 - Conventional Flue		75%	5.1kW	920 x 622 x 40
Riva2 670 - Balanced Flue		82%	5.6kW	920 x 622 x 40

^Δ Dimensions given are those overall visible upon installation. Efficiency figures are based upon the maximum heat output achieved in the options available. For more detailed technical information, including firebox dimensions and installation requirements, please see pages 126-127

The Riva2 530 and 670 are both compatible with our linerless flue kit for a simplified installation. Please see page 81 for further information.

Riva2 530 & 670 Verve



Riva2 670 Verve in Graphite with Black Reeded lining



Riva2 530 Verve in Metallic Bronze with Vermiculite lining



Riva2 670 Verve in Graphite with Brick-effect lining

The stylish Verve is a 3D frame designed to create maximum impact in your home. Designed with a gentle curving form that can be appreciated from all angles, the Verve is available in sophisticated Graphite or can be tailored to your room with one of Gazco's vibrant colour finishes: Metallic Red, Metallic Bronze or Ivory to create an even stronger style statement.

A Riva2 Verve can be further styled with a choice of three lining options to complement the beautiful log-effect fire, so whether it's for a sumptuous sitting room or a stylish study, you can enjoy a thoroughly contemporary fire and add a touch of warming luxury to your home.

Finishes

Graphite
Metallic Red
Metallic Bronze
Ivory

Linings

Vermiculite
Brick Effect
Black Reeded

Fuel Bed

Logs

Command Controls

Programmable
Thermostatic remote



Colour finishes are shown on pages 48 - 49

Fire Choices

	Efficiency	Heat Output	Dimensions ^Δ w x h x d (mm)
Riva2 530 - Conventional Flue	75%	5.1kW	690 x 835 x 59
Riva2 530 - Balanced Flue	82%	5.4kW	690 x 835 x 59
Riva2 670 - Conventional Flue	75%	5.1kW	1325 x 621 x 57
Riva2 670 - Balanced Flue	82%	5.6kW	1325 x 621 x 57

^Δ Dimensions given are those overall visible upon installation. Efficiency figures are based upon the maximum heat output achieved in the options available. For more detailed technical information, including firebox dimensions and installation requirements, please see pages 126-127

The Riva2 530 and 670 are both compatible with our linerless flue kit for a simplified installation. Please see page 81 for further information.



Riva2 530 Verve in Graphite with Black Reeded lining

Riva2 530 & 670 Ellingham



Riva2 530 Ellingham with Vermiculite lining



Riva2 670 Ellingham with Brick-effect lining

Continuing on from the Riva2 500, the Ellingham is also a handsome cast iron addition to the Riva2 530 and 670 frame range. Although classic in its nature, the Ellingham sits equally well in both traditional and contemporary interiors, and its Matt Black finish sets off the beautiful flame picture within.

The Riva2 530 and 670 are both compatible with our linerless flue kit for a simplified installation. Please see page 81 for further information.

Finish
Matt Black Cast Iron

Linings
Vermiculite
Brick Effect
Black Reeded

Fuel Bed
Logs

Command Controls
Programmable
Thermostatic remote



Fire Choices		Efficiency	Heat Output	Dimensions ^A w x h x d (mm)
Riva2 530 - Conventional Flue		75%	5.1kW	815 x 759 x 75
Riva2 530 - Balanced Flue		82%	5.4kW	815 x 759 x 75
Riva2 670 - Conventional Flue		75%	5.1kW	940 x 627 x 75
Riva2 670 - Balanced Flue		82%	5.4kW	940 x 627 x 75

^A Dimensions given are those overall visible upon installation. Efficiency figures are based upon the maximum heat output achieved in the options available. For more detailed technical information, including firebox dimensions and installation requirements, please see pages 126-127



Riva2 530 Ellingham with Black reeded lining



*Riva2 670 Verve XS in Graphite
with Brick-effect lining*

Riva2 670 Verve XS



Riva2 670 Verve XS in Ivory with Vermiculite lining



Riva2 670 Verve XS in Graphite with Black Reeded lining shown with Gazco's Slate Di Savoia Mosaic Finish Fire Surround Tiles

Specifically designed for the Riva2 670, the Verve XS offers the same subtly curving form of the standard Verve frame but with slimmer proportions to suit narrower walls or spaces.

The Verve XS comes in smart Graphite or can be finished in one of three striking additional colour options to suit your interior tastes. The highly realistic fire is enhanced by Gazco's stunning glowing ember bed, offering all the ambiance of a real log flame in the modern convenience of a high efficiency gas fire.

Finishes

Graphite
Metallic Red
Metallic Bronze
Ivory

Linings

Vermiculite
Brick Effect
Black Reeded

Fuel Bed

Logs

Command Controls

Programmable
Thermostatic remote



Colour finishes are shown on pages 48 - 49

Fire Choices

Efficiency

Heat Output

Dimensions^Δ w x h x d (mm)

Riva2 670 - Conventional Flue		75%	5.1kW	1000 x 621 x 56
Riva2 670 - Balanced Flue		82%	5.6kW	1000 x 621 x 56

^Δ Dimensions given are those overall visible upon installation. Efficiency figures are based upon the maximum heat output achieved in the options available. For more detailed technical information, including firebox dimensions and installation requirements, please see pages 126-127

The Riva2 670 is compatible with our linerless flue kit for a simplified installation. Please see page 81 for further information.

Riva2 800 & 1050

The Riva2 800 & 1050 take large format gas fires to a new level with high efficiency heating and striking designer aesthetics. These stunning fires are available with a choice of styling options, additionally the Riva2 800 is compatible with Gazco's collection of six beautifully crafted, classic stone mantels.



*Riva2 1050 Icon XS with Vermiculite lining.
Shown with Zelo Slimline Grey Fire Surround Tiles.*

Stunning Flame Visuals...

An enticing focal point for your home, both the Riva2 800 and 1050 offer incredible flame visuals that deliver all the ambiance of a solid fuel fire. At the cutting-edge of fire design, the glowing ember fuel bed provides a realistic glow; and the advanced dual burner system gives you the option to choose between using one or two burners, allowing you to create your perfect atmosphere and heat output.

Convected heat enters the room through high level vents which need to be incorporated into your installation, providing cosy ambient heating throughout your living space.

Frame Options (see pages 64 - 65)

The Riva2 800 & 1050 come with a number of styling and frame options that have all been thoughtfully designed to enhance the impressive dimensions of these fires. Choose from the minimalist styling of the frameless Edge or the Icon XS with a highly reflective black glass finish that is sure to add a touch of glamour and opulence to your interior décor.

For hearth mounted installations, the graceful proportions of the Sorrento stone surround enables you to recreate a style reminiscent of a traditional fireplace whilst still maintaining a thoroughly contemporary look for your living space. Available in either Graphite Granite or Natural Limestone.

For an altogether more traditional look, pair your Riva2 800 with one of six timeless and elegant stone mantels, expertly blending classical fireplace styling with the very latest in heating design and technology.

Lining Options

To further tailor your Riva2 800 or 1050 to your own setting, there is a choice of two stylish linings, each designed to offer a completely different look for this impressively proportioned fire. Choose from the timeless black reeded lining for a more classic look or opt for the vermiculite lining which extends the light of the fire glow.



Black Reeded Lining



Vermiculite Lining



Riva2 800 Sorrento in Natural Limestone with Black Reeded lining

Remote Control

Riva2 800 & 1050 fires come complete with a state-of-the-art Programmable Thermostatic remote control as standard. This allows remote operation of everything from ignition to extinguish as well as incorporating the benefits of a programmable timer and thermostat. Should you mislay your handset, the fires also come complete with a flat Touch Control panel that can be discreetly wall mounted up to 2.5 metres away from the fire, allowing you to ignite, extinguish and control the flame height with ease.



Programmable Thermostatic Remote and Flat Touch Control Panel

Riva2 800 & 1050 Edge



Riva2 800 Edge with Black Reeded lining. Shown with Gazco's Cape Town Grey Matt fire surround tiles



Riva2 800 Edge with Vermiculite lining



Developed for those who want the visual impact and heat of a flaming log fire without the inconvenience of carrying logs and removing ash, the Riva2 800 & 1050 Edge offers high efficiency in a frameless gas fire. With advanced dual burner control to give you complete control allowing you to create the perfect flame visuals and heat output to suit your mood.

The frameless look allows you to create a more minimalist décor, to which tiles or wall colours and finishes can be added to maximise the overall impression of depth and space. Gazco offers a range of fireplace tile surround packages to go with the Riva2 Edge fires.

Although the Riva2 800 & 1050 are available as a balanced flue fire only, it can be installed into a conventional chimney by using the optional Riva2 renovation kit. Details of this can be found on page 128.



The Riva2 800 Edge models can be combined with a choice of Gazco's high quality stone mantels - see pages 104 - 111 for details.

Fire Choices

Riva2 800 - Balanced Flue



Efficiency

84%

Heat Output

7.98kW

Dimensions^A w x h (mm)

870 x 760

Riva2 1050 - Balanced Flue



84%

7.98kW

1142 x 552

^A Dimensions given are those overall visible upon installation. Efficiency figures are based upon the maximum heat output achieved in the options available. For more detailed technical information, including firebox dimensions and installation requirements, please see pages 127-128

Fuel Bed

Logs

Linings

Vermiculite
Black Reeded

Command Controls

Programmable
Thermostatic remote





Riva2 1050 Edge with Black Reeded lining

Riva2 800 & 1050 Icon XS



Riva2 1050 Icon XS with Black Reeded lining.



Riva2 1050 Icon XS with Vermiculite lining.

The Icon XS is a truly awe-inspiring frame and the perfect complement to the large format Riva2 800 & 1050 fires. Iconic in both name and nature, this luxuriant frame is designed to make an impact. The resplendent, highly reflective black glass with clean geometric lines, offers unrivalled flair and elegance to today's modern aesthetics whilst being equally at home in more classically styled interiors, ensuring the Icon will blend seamlessly with your own decorative tastes.

The Riva2 800 & 1050 are high performing fires, that have a heat output of up 7.98kW. The virtually invisible glass window offers an uninterrupted view of the stunningly realistic logs with innovative glowing ember effect fuel bed, whilst the Programmable Thermostatic remote control provides the finishing touch - perfect comfort at just the touch of a button.

- Finish**
Black Glass
- Fuel Bed**
Logs
- Linings**
Vermiculite
Black Reeded
- Command Controls**
Programmable
Thermostatic remote



Fire Choices	Efficiency	Heat Output	Dimensions ^A w x h x d (mm)
Riva2 800 - Balanced Flue	84%	7.98kW	1173 x 1068 x 24
Riva2 1050 - Balanced Flue	84%	7.98kW	1443 x 861 x 24

^A Dimensions given are those overall visible upon installation. Efficiency figures are based upon the maximum heat output achieved in the options available. For more detailed technical information, including firebox dimensions and installation requirements, please see pages 127-128.

Additional image of the Riva2 1050 Icon XS is shown on page 96.



Riva2 800 Icon XS with Vermiculite lining

Riva2 800 & 1050 Sorrento



Riva2 1050 Sorrento in Graphite Granite with Vermiculite lining



Riva2 1050 Sorrento in Limestone with Black Reeded lining



The Sorrento surround has been designed to provide a contrast between the timeless beauty of natural stone and the advanced technology of the Riva2 800 & 1050. The simple lines of the surround provide the perfect frame to the warming glow of the highly realistic log fire, to establish a true focal point in your room.

Operation is impressive too, with all functions operated by the fully Programmable Thermostatic remote control.

Although the Riva2 800 & 1050 are available as a balanced flue fire only, they can be installed into a conventional chimney by using the optional Riva2 renovation kit. Details of this can be found on page 128.

Finishes
Natural Limestone
Graphite Granite

Fuel Bed
Logs

Linings
Vermiculite
Black Reeded

Command Controls
Programmable
Thermostatic remote



Fire Choices

		Efficiency	Heat Output	Dimensions ^A w x h x d (mm)
Riva2 800 Balanced Flue		84%	7.98kW	1260 x 1009 x 200
Riva2 1050 Balanced Flue		84%	7.98kW	1530 x 801 x 200

^A Dimensions given are those overall visible upon installation. Efficiency figures are based upon the maximum heat output achieved in the options available. For more detailed technical information, including firebox dimensions and installation requirements, please see pages 127-128.

Additional image of the Riva2 800 Sorrento is shown on page 97.



Riva2 800 Sorrento with Vermiculite lining in Natural Limestone

Riva2 Stone Mantels



*Riva2 750HL Edge with Brick Effect lining and
Claremont Mantel in Limestone with matching slip sets*

Traditional Style with a Modern Slant...

Gazco's collection of six high quality stone mantels and optional hearths are available in a choice of either Limestone or Antique White Marble, each piece truly unique by virtue of the naturally occurring veining, subtle tonal differences and indeed even small fossils that may be found in the limestone. A beautiful and natural complement to many of the high efficiency fires shown in this brochure and the perfect way to ensure a grand finish and a timeless fireplace for your home.



Mantel Styles	Claremont	Cavendish Bolection	Georgian Roundel	Grafton	Sandringham	Victorian Corbel
Dimensions ^Δ w x h (mm)	1555 x 1143	1460 x 1320	1460 x 1082	1415 x 1165	1550 x 1220	1525 x 1170



*Riva2 750HL & 800 slip sets are available from Gazco. Bespoke sourcing will be required for Riva2 500 slip sets or back panels for any other fires.
^Δ Overall visible dimensions upon installation. For more detailed information, including firebox dimensions, please see pages 124 - 127.



Victorian Corbel



Claremont



Sandringham



Cavendish Bolection



Georgian Roundel



Grafton

(All the above images are shown with a Riva2 750HL fire and matching slip sets)

Riva2 Stone Mantels



Riva2 500 Edge with Vermiculite Lining and Sandringham Mantel in Limestone



Riva2 530 Designio2 Steel in Graphite with Vermiculite Lining and Grafton Mantel in Limestone



Riva2 800 Edge with Black Reeded lining and Claremont Mantel and hearth in Limestone with matching slip sets

In addition to the wide choice of frame styling options shown throughout this brochure, Gazco offer a selection of solid stone mantels to add some authentic period charm into your fireplace setting; each with a choice of six historic designs from Georgian and Victorian times, beautifully carved in your choice of natural Limestone or Antique White Marble.

Mantel Styles	Dimensions w x h (mm)	Opening Dimensions w x h (mm)
Claremont	1555 x 1143	915 x 915
Cavendish Bolection	1460 x 1320	915 x 915
Georgian Roundel	1460 x 1082	915 x 915
Grafton	1415 x 1165	915 x 915
Sandringham	1550 x 1220	915 x 915
Victorian Corbel	1525 x 1170	915 x 915

Stone Choices

Antique White Marble
Limestone

Linings

Vermiculite (500 & 800)
Fluted Vermiculite (750HL)
Black Reeded (500, 750HL & 800)
Brick Effect (500 & 750HL)

Fire Choices

Fire Choices	Pages
Riva2 500 Edge	68 - 69
Riva2 530 Designio2 Glass	82 - 83
Riva2 530 Designio2 Steel	84 - 85
Riva2 750HL Edge	68 - 69
Riva2 800 Edge	98 - 99

For further details on the complementary hearth options and slip sets, please see page 127.

Riva2 750HL Edge with Brick Effect lining and Grafton Mantel, slip sets and hearth in Antique White Marble





Riva2 Stone Mantels (continued)



Victorian Corbel Mantel detail



Riva2 750HL with Black Reeded lining and Cavendish Bolection Mantel and slip sets in Limestone



Riva2 500 with Brick Effect lining and Victorian Corbel Mantel in Antique White Marble

With matching stone slip sets available, these impressive stone mantels have been specifically designed to complement the Riva2 750HL and Riva2 800 Edge fires. However, by incorporating a back panel of your choosing, these work equally well with the Riva2 500 Edge as well as the Riva2 530 fires when paired with the contemporary Designio2 Glass or Steel frames. Your styling options continue with a choice of distinctive lining options, allowing you to choose a look that will best suit you and your home.

Mantel Styles	Dimensions w x h (mm)	Opening Dimensions w x h (mm)
Claremont	1555 x 1143	915 x 915
Cavendish Bolection	1460 x 1320	915 x 915
Georgian Roundel	1460 x 1082	915 x 915
Grafton	1415 x 1165	915 x 915
Sandringham	1550 x 1220	915 x 915
Victorian Corbel	1525 x 1170	915 x 915

Stone Choices

Antique White Marble
Limestone

Linings

Vermiculite (500 & 800)
Fluted Vermiculite (750HL)
Black Reeded (500, 750HL & 800)
Brick Effect (500 & 750HL)

Fire Choices

Fire Choices	Pages
Riva2 500 Edge	68 - 69
Riva2 530 Designio2 Glass	82 - 83
Riva2 530 Designio2 Steel	84 - 85
Riva2 750HL Edge	68 - 69
Riva2 800 Edge	98 - 99

For further details on the complementary hearth options and slip sets, please see page 127.

Riva2 Stone Mantels (continued)



Riva2 750HL Edge with Fluted Vermiculite lining and Georgian Roundel Mantel in Antique White Marble with matching slip sets



Riva2 500 Edge with Black Reeded lining and Cavendish Bolection Mantel in Limestone



Sandringham Mantel detail

The Riva2 stone mantel collection features the finest quality hand-finished craftsmanship and provide the ultimate in aesthetic and tactile appeal for your home. Paired with a high efficiency Riva2 fire, you can enjoy all the authentic charm of a highly realistic log-effect fire in a timeless mantel fireplace, fully operational from the comfort of your favourite armchair using the convenient Programmable Thermostatic remote control supplied.

Mantel Styles	Dimensions w x h (mm)	Opening Dimensions w x h (mm)
Claremont	1555 x 1143	915 x 915
Cavendish Bolection	1460 x 1320	915 x 915
Georgian Roundel	1460 x 1082	915 x 915
Grafton	1415 x 1165	915 x 915
Sandringham	1550 x 1220	915 x 915
Victorian Corbel	1525 x 1170	915 x 915

Stone Choices

Antique White Marble
Limestone

Linings

Vermiculite (500 & 800)
Fluted Vermiculite (750HL)
Black Reeded (500, 750HL & 800)
Brick Effect (500 & 750HL)

Fire Choices

Fire Choices	Pages
Riva2 500 Edge	68 - 69
Riva2 530 Designio2 Glass	82 - 83
Riva2 530 Designio2 Steel	84 - 85
Riva2 750HL Edge	68 - 69
Riva2 800 Edge	98 - 99

For further details on the complementary hearth options and slip sets, please see page 127.

Riva2 530 Designio2 Glass with
Brick-effect lining and Claremont
Limestone Mantel





Logic HE with coal effect fuel bed. Shown with Arts front in Polished Chrome-effect and Polished Steel-effect Box Profil2 frame. Also shown: White Brompton mantel from Stovax

Gazco Inset Fires



Logic HE with white stone fuel bed and Designio2 Glass complete front with Slide control



E-Studio with white stone fuel bed and Futura complete front



Logic HE, coal effect fire with Polished Chrome-effect Chartwell front with Polished Stainless Steel Arts2 frame

Designed to warm the very heart of your home, there is nothing like the ambiance created by a Gazco Inset fire. It's a natural focal point around which family and friends will intuitively gather and brings you the promise of a cosy comfort throughout those long winter nights; even if you don't have a chimney!

Choose from a range of either hearth or wall mounted gas fires utilising advanced technology to create a wonderful flame picture, impressive performance and high efficiency heating when you opt for one of Gazco's E-Box™, E-Studio™ or Logic HE fires. Depending on the model you can enjoy either an exquisite coal, white stone or pebble fuel effect for your fire, finished with your choice of frame or front from a wide style selection.

Whether you want to achieve an up-to-the-minute, contemporary look or have your heart set on a more traditionally designed fire, you will find a choice of flame effects and elegant frame options to suit your decorative style and budget.

Each model has been specially developed with ease of installation in mind, giving you excellent value for money through reduced fitting costs – and in most cases, you do not have to have a wall or floor vent installed either.

For more information, or to view our complete range of Inset fires, simply visit www.gazco.com and choose the perfect fireplace for a warm welcome home, every time.

To view the Gazco Inset Fires brochure, simply scan this QR code, visit www.gazco.com or speak to your local Gazco retailer.



Have you considered Electric?



Studio Electric 1 Evolve in Walnut with Polished Steel Infills



Studio Electric Inset 105



Riva2 Electric 70 with Victorian Corbel mantel in Natural Limestone

In addition to the wide selection of gas fires shown in this brochure, Gazco also offers an extensive array of electric fires in a separate dedicated brochure.

Using the latest Flame-effect technology, Gazco has created a beautiful range of fires and stoves that provide a versatile and stunning focal point for any home - all without the need for a chimney!

With hang-on-the wall, hearth mounted and frameless fires alongside a wide selection of contemporary frames and matching classic stone mantels; Gazco's exciting new electric range has it all.



Whether you want to achieve a modern contemporary look or a more classic, traditional interior, the Gazco Electric Fires and Stoves brochure has the perfect solution whatever your style or budget.

To view the Gazco Electric Fires & Stoves brochure, simply scan this QR code, visit www.gazco.com or speak to your local Gazco retailer.



ELECTRIC
FIRES & STOVES



Exclusive Fireplace Tile Surrounds



*Riva2 1050 Icon XS with Vermiculite lining.
Shown with Zelo Slimline Grey fire surround tiles.*



*Studio 22 Verve in Ivory
Shown with Burnt Sienna fire surround tiles*



Riva2 500 Evoke Glass with Metallic Bronze rear & Brick-effect lining. Shown with Pretoria Anthracite Polished & Durban White Matt fire surround tiles

The space in which you live is an expression of your individual style and at the very heart of your home is the fireplace. It is a focal point that not only extends the warmest of welcomes to your family and friends, and the one around which they will gather naturally, but it also offers you the opportunity to make a design statement that marks out the room even when the fire is not lit.

Many of Gazco's contemporary fires are designed to fit into an existing chimney breast or specially built studwork structure. Accordingly, the wall itself can be used to enhance the impressive appliance you have already chosen. This unique collection of 31 porcelain and natural stone tiles has been carefully selected to help you create your ultimate look. The range is continually being refined with stylish additions, so please ask your Gazco retailer for details, or download the latest brochure from www.gazco.com.

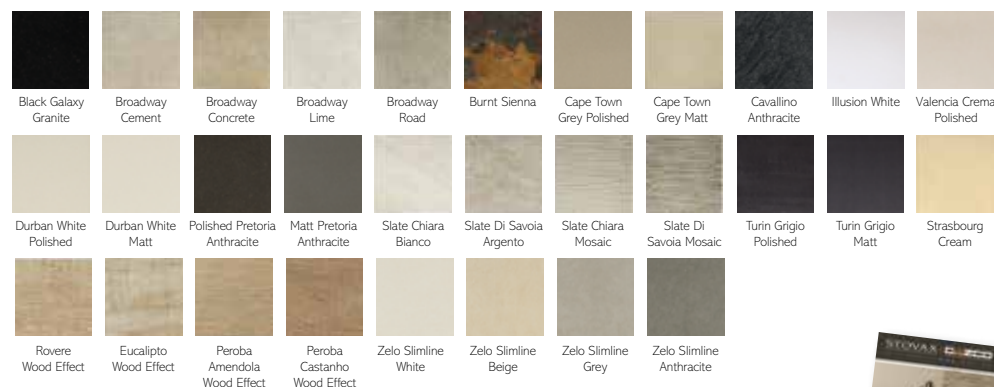

To view the Fireplace Tile Surrounds brochure, simply scan this QR code, visit www.gazco.com or speak to your local Gazco retailer.





*Riva2 670 Verve XS in Graphite with Black Reeded lining.
Shown with Slate Di Savoia Mosaic Finish fire surround tiles*

Technical Information

The following pages provide the dimensional, heat input/output, efficiency and product code information you will need to choose your new Gazco fire. For more detailed specifications, please consult your Gazco retailer. Complete installation instructions may be downloaded from www.gazco.com.

Studio 1, 2 & 3 Fire Information

OPEN FRONTED FIRES

Product Code	Description	Flue Type	Gas Type	Fuel Effect	Heat Input	Heat Output	Efficiency	Remote Control	Lining
⊗ 8700CHEC	Studio 1	Conventional	Nat. Gas	White Stones	6.90kW	1.72kW	25%	Standard	N/A
⊗ P8700CHEC	Studio 1	Conventional	LPG	White Stones	6.90kW	1.72kW	25%	Standard	N/A
8701CHEC	Studio 2	Conventional	Nat. Gas	White Stones	8.80kW	2.20kW	25%	Standard	N/A
P8701CHEC	Studio 2	Conventional	LPG	White Stones	9.30kW	2.30kW	25%	Standard	N/A
8702CHEC	Studio 3	Conventional	Nat. Gas	White Stones	13.20kW	3.30kW	25%	Standard	N/A
P8702CHEC	Studio 3	Conventional	LPG	White Stones	13.70kW	3.40kW	25%	Standard	N/A

GLASS FRONTED FIRES

⊗ 8700CFCHEC	Studio 1	Conventional	Nat. Gas	White Stones	6.90kW	4.85kW	70%	Prog. Thermostatic	Enamelled Black
⊗ P8700CFCHEC	Studio 1	Conventional	LPG	White Stones	6.90kW	4.85kW	70%	Prog. Thermostatic	Enamelled Black
⊗ 8700BFCHEC	Studio 1	Balanced flue	Nat. Gas	White Stones	6.30kW	5.10kW	81%	Prog. Thermostatic	Enamelled Black
⊗ P8700BFCHEC	Studio 1	Balanced flue	LPG	White Stones	6.10kW	4.95kW	81%	Prog. Thermostatic	Enamelled Black
⊗ 8700CFLECV	Studio 1	Conventional	Nat. Gas	Logs	6.70kW	4.70kW	70%	Prog. Thermostatic	Vermiculite
⊗ P8700CFLECV	Studio 1	Conventional	LPG	Logs	6.90kW	4.83kW	70%	Prog. Thermostatic	Vermiculite
⊗ 8700CFLECR	Studio 1	Conventional	Nat. Gas	Logs	6.70kW	4.70kW	70%	Prog. Thermostatic	Black Reeded
⊗ P8700CFLECR	Studio 1	Conventional	LPG	Logs	6.90kW	4.83kW	70%	Prog. Thermostatic	Black Reeded
⊗ 8700BFLECV	Studio 1	Balanced flue	Nat. Gas	Logs	6.40kW	5.20kW	81%	Prog. Thermostatic	Vermiculite
⊗ P8700BFLECV	Studio 1	Balanced flue	LPG	Logs	6.30kW	5.10kW	81%	Prog. Thermostatic	Vermiculite
⊗ 8700BFLECR	Studio 1	Balanced flue	Nat. Gas	Logs	6.40kW	5.20kW	81%	Prog. Thermostatic	Black Reeded
⊗ P8700BFLECR	Studio 1	Balanced flue	LPG	Logs	6.30kW	5.10kW	81%	Prog. Thermostatic	Black Reeded
8701CFCHEC	Studio 2	Conventional	Nat. Gas	White Stones	8.30kW	6.50kW	78%	Prog. Thermostatic	Enamelled Black
P8701CFCHEC	Studio 2	Conventional	LPG	White Stones	8.30kW	6.50kW	78%	Prog. Thermostatic	Enamelled Black
⊗ 8701BFCHEC	Studio 2	Balanced flue	Nat. Gas	White Stones	8.40kW	6.80kW	81%	Prog. Thermostatic	Enamelled Black
⊗ P8701BFCHEC	Studio 2	Balanced flue	LPG	White Stones	7.30kW	5.92kW	81%	Prog. Thermostatic	Enamelled Black
8701CFLECV	Studio 2	Conventional	Nat. Gas	Logs	8.50kW	6.65kW	78%	Prog. Thermostatic	Vermiculite
P8701CFLECV	Studio 2	Conventional	LPG	Logs	8.80kW	6.85kW	78%	Prog. Thermostatic	Vermiculite
8701CFLECR	Studio 2	Conventional	Nat. Gas	Logs	8.50kW	6.65kW	78%	Prog. Thermostatic	Black Reeded
P8701CFLECR	Studio 2	Conventional	LPG	Logs	8.80kW	6.85kW	78%	Prog. Thermostatic	Black Reeded
⊗ 8701BFLECV	Studio 2	Balanced flue	Nat. Gas	Logs	8.60kW	7.00kW	81%	Prog. Thermostatic	Vermiculite
⊗ P8701BFLECV	Studio 2	Balanced flue	LPG	Logs	8.00kW	6.50kW	81%	Prog. Thermostatic	Vermiculite
⊗ 8701BFLECR	Studio 2	Balanced flue	Nat. Gas	Logs	8.60kW	7.00kW	81%	Prog. Thermostatic	Black Reeded
⊗ P8701BFLECR	Studio 2	Balanced flue	LPG	Logs	8.00kW	6.50kW	81%	Prog. Thermostatic	Black Reeded
⊗ 8702BFCHEC	Studio 3	Balanced flue	Nat. Gas	White Stones	9.00kW	7.30kW	81%	Prog. Thermostatic	Enamelled Black
⊗ P8702BFCHEC	Studio 3	Balanced flue	LPG	White Stones	9.00kW	7.30kW	81%	Prog. Thermostatic	Enamelled Black
⊗ 8702BFLECV	Studio 3	Balanced flue	Nat. Gas	Logs	9.00kW	7.30kW	81%	Prog. Thermostatic	Vermiculite
⊗ P8702BFLECV	Studio 3	Balanced flue	LPG	Logs	9.00kW	7.30kW	81%	Prog. Thermostatic	Vermiculite
⊗ 8702BFLECR	Studio 3	Balanced flue	Nat. Gas	Logs	9.00kW	7.30kW	81%	Prog. Thermostatic	Black Reeded
⊗ P8702BFLECR	Studio 3	Balanced flue	LPG	Logs	9.00kW	7.30kW	81%	Prog. Thermostatic	Black Reeded



Installing Televisions above Open Fronted Studio Fires

On a normal flue which is functioning correctly, Open Fronted Studios do not create a particularly hot environment on the wall above where they are installed. Therefore, it may be possible to install Plasma or LCD TV's above them, as long as the distance to the TV is a minimum of 450mm from the top of the fire and as long as it has been checked with the TV manufacturer's installation instructions with regard to installation and heat proximity. If in doubt please contact and check with your TV manufacturer.

Glass Fronted Studio Fires Gazco does not recommend installation of televisions above Glass Fronted Studio fires.

Studio 1, 2 & 3 Fire Information (continued)

Additional Information For Open Fronted Studio Fires (mm)

Appliance dimensions (mm)

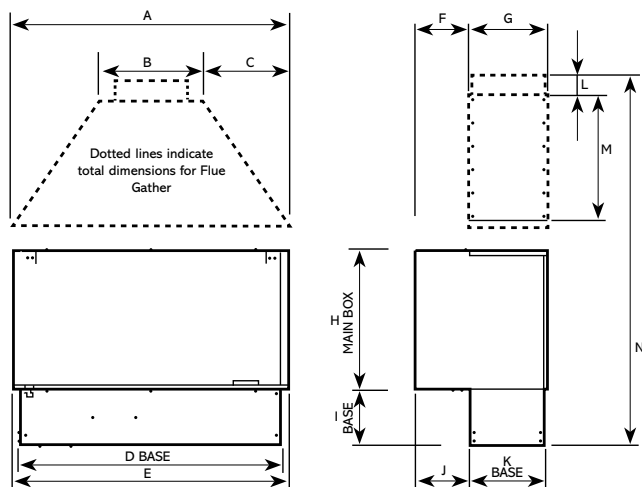

Dimension		Studio 1	Studio 2	Studio 3
A	Gather width	664	864	1254
B	Gather top	250	250	325
C	Gather taper	207	307	465
D	Base width	635	835	1225
E**	Box width	660	860	1250
F	Max. lintel width	130	130	130
G	Gather depth	187	187	187
H**	Box height	334	334	334
I*	Base height	133	133	133
J	Base depth	130	130	130
K	Base	182	182	182
L	Spigot height	50	50	50
M	Gather height	300	300	700
N	Total height	817	817	1217

* adjustable feet can increase base height by up to 235 mm

** If installed with one of the Studio frames, a 5mm space must be left around the front edge of the appliance.

CHIMNEY TYPES

Studio 1

- **Class 1 brick built flue**
 - Can be fitted without the optional flue gather if the chimney is sound.
 - If the optional gather is used, then it must be connected to a 7" flexible flue liner suitable for gas.
- **Pre-fabricated 7" twin wall flue system suitable for gas**
 - Must be fitted with the optional flue gather.

Studio 2 and 3

- **Class 1 brick built flue**
 - Must be fitted with the flue gather.
- **Pre-fabricated 7" twin wall flue system suitable for gas**
 - Must be fitted with the flue gather.

Note: it is possible to install the Studio 2 and 3 into a Class 1 brick flue. However, this type of installation should only be undertaken by chimney specialists. This is because it will require the front wall and structure of the chimney breast to be extensively cut away to allow enough width to fit the fire and also provide access to the top of the gather to allow either -

- Connection of a 7" flexible flue liner suitable for gas
- Creation of a smooth transition between the top of the gather and the flue

Please note that carbon/soot deposits may be visible on inner back wall of the Open Fronted Studio fires due to variances in performance of flue systems, particularly in different prevailing weather conditions

Additional Information For Glass Fronted Studio Fires (mm)

Conventional Flue Installation

The conventionally flued Glass Fronted Studio has been designed with ease of installation in mind and can be installed two ways:

- 1) Direct connection to a 5" flue liner or 5" twin wall gas vent system
- 2) No additional fluing is needed when it is installed into an existing builders opening below a masonry chimney and sealed to the fireplace opening (assuming that the chimney is of sound construction).

* For more Balanced Flue information and options please refer to our Concentric Flue System brochure which can be viewed or downloaded online at www.gazco.com

Conventional Flue

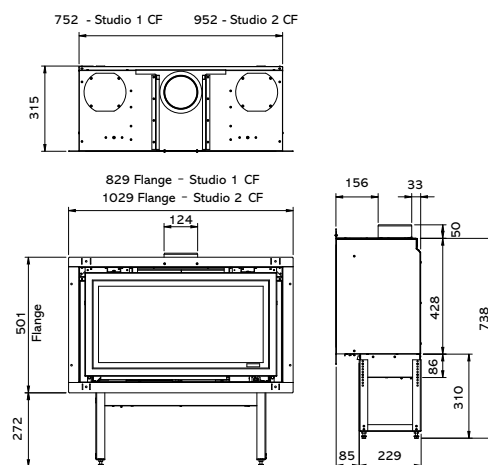

Balanced Flue*

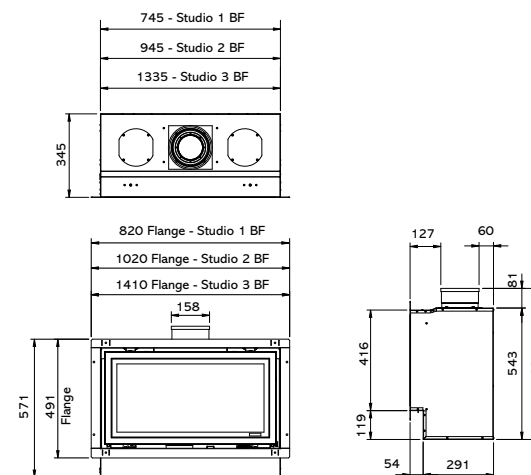

Studio 1, 2 & 3 Frame Information

Description	Frame Finish	Open Fronted Product Code	Frame Size (mm)			Glass Fronted CF Product Code	Frame Size (mm)			Glass Fronted BF Product Code	Frame Size (mm)		
			w	h	d		w	h	d		w	h	d
STUDIO 1													
Bauhaus	Anthracite	8711AN	764	439	28	8711CFAN01	860	534	28	8711BFAN01	850	524	28
Bauhaus	Polished Stainless Steel	8711P	764	439	28	8711CFSS01	860	534	28	8711BFSS01	850	524	28
Profil	Anthracite	8710AN	750	426	13	8710CFAN01	846	520	13	8710BFAN01	836	510	13
Profil	Polished Stainless Steel	8710P	750	426	13	8710CFSS01	846	520	13	8710BFSS01	836	510	13
Steel 2	Graphite	923-486	1118	478	13	923-883	1264	528	27	923-883	1264	528	27
Expression	Graphite	-	N/A	N/A	N/A	923-546	950	624	40	923-656	940	614	40
Verve	Graphite	923-437	1264	528	54	923-300	1264	528	53	923-300	1264	528	53
Glass	Black Glass	923-022	1264	528	17	923-628	1264	528	29	923-628	1264	528	29
Firenza	Black Granite	8723GBK	1200	600	20	-	N/A	N/A	N/A	-	N/A	N/A	N/A
Pienza	White Limestone	8723LMS	1200	600	20	-	N/A	N/A	N/A	-	N/A	N/A	N/A

STUDIO 2

Bauhaus	Anthracite	8718AN	964	439	28	8718CFAN02	1060	534	28	8718BFAN02	1050	524	28
Bauhaus	Polished Stainless Steel	8718P	964	439	28	8718CFSS02	1060	534	28	8718BFSS02	1050	524	28
Profil	Anthracite	8717AN	950	426	13	8717CFAN02	1046	520	13	8717BFAN02	1036	510	13
Profil	Polished Stainless Steel	8717P	950	426	13	8717CFSS02	1046	520	13	8717BFSS02	1036	510	13
Steel 2	Graphite	923-738	1354	508	13	923-556	1500	528	27	923-556	1500	528	27
Expression	Graphite	-	N/A	N/A	N/A	923-574	1150	624	40	923-709	1140	614	40
Verve	Graphite	923-542	1500	528	54	923-514	1500	528	53	923-514	1500	528	53
Glass	Black Glass	923-135	1500	528	17	923-535	1500	528	29	923-535	1500	528	29
Firenza	Black Granite	8724GBK	1500	600	20	-	N/A	N/A	N/A	-	N/A	N/A	N/A
Pienza	White Limestone	8724LMS	1500	600	20	-	N/A	N/A	N/A	-	N/A	N/A	N/A

STUDIO 3

Bauhaus	Anthracite	8721AN	1354	439	28	-	N/A	N/A	N/A	8721BFAN03	1440	524	28
Bauhaus	Polished Stainless Steel	8721P	1354	439	28	-	N/A	N/A	N/A	8721BFSS03	1440	524	28
Profil	Anthracite	8720AN	1340	426	13	-	N/A	N/A	N/A	8720BFAN03	1426	510	13
Profil	Polished Stainless Steel	8720P	1340	426	13	-	N/A	N/A	N/A	8720BFSS03	1426	510	13
Steel 2	Graphite	923-154	1844	528	13	-	N/A	N/A	N/A	923-008	1990	528	27
Expression	Graphite	-	N/A	N/A	N/A	-	N/A	N/A	N/A	923-753	1530	614	40
Verve	Graphite	923-355	1990	528	54	-	N/A	N/A	N/A	923-729	1990	528	53
Glass	Black Glass	923-591	1990	528	17	-	N/A	N/A	N/A	923-084	1990	528	29

Studio Frame Colour Supplements



A choice of three colours is available to choose from on Studio Profil and Bauhaus Anthracite Fronts and Steel 2, Expression and Verve Graphite fronts (see pages 48-49), these are: Metallic Red, Metallic Bronze and Ivory. Please use the product code provided with the following suffix for your choice of colour: **Metallic Red (RD), Metallic Bronze (BZ) and Ivory (IV).**

- for example: Studio 1 Open Fronted Profil in Metallic Red = 8710ANRD



Metallic Red

Metallic Bronze

Ivory

Studio 1, 2 & 3 Options & Accessories

OPEN FRONTED STUDIO FIRES

Product Code	Description
STUDIO 1	
8714GBK	Black Granite linings
8713	Flue gather*
STUDIO 2	
8715GBK	Black Granite linings
STUDIO 3	
8716GBK	Black Granite linings

* Flue gather automatically included with Open Fronted Studio 2 & 3 Fires.

GLASS FRONTED STUDIO FIRES

Product Code	Description
8572	Warm air ducting kit (2 outlets)
8524	Balanced flue kit - vertical †
999-620	Remote system mains adaptor

STUDIO 1	
8727CFEK01	Edge fitting kit for conventional flue
8727BFEK01	Edge fitting kit for balanced flue †
8727CFCW01	Cool Wall fitting kit for conventional flue
8727BFCW01	Cool Wall fitting kit for balanced flue †
8534	Balanced flue kit - up and out †
923-517	Black reed lining set for conventional flue ‡
923-607	Black reed lining set for balanced flue ‡

STUDIO 2	
8727CFEK02	Edge fitting kit for conventional flue
8727BFEK02	Edge fitting kit for balanced flue †
8727CFCW02	Cool Wall fitting kit for conventional flue
8727BFCW02	Cool Wall fitting kit for balanced flue †
8509	Balanced flue kit - up and out †
923-744	Black reed lining set for conventional flue ‡
923-476	Black reed lining set for balanced flue ‡

STUDIO 3	
8727BFEK03	Edge fitting kit for balanced flue †
8727BFCW03	Cool Wall fitting kit for balanced flue †
8567	Balanced flue kit - up and out †
923-381	Black reed lining set for balanced flue ‡

† For more Balanced Flue information and options please refer to our Concentric Flue System brochure which can be viewed or downloaded online at www.gazco.com

‡ Available as an upgrade to Studio fires with a log effect fuel bed

UPGRADABLE GLASS BEAD FUEL EFFECTS ◊

Product Code	Description
STUDIO 1 - OPEN & GLASS FRONTED	
923-797	Clear glass fuel effect upgrade
923-735	Black glass fuel effect upgrade
923-746	Red glass fuel effect upgrade**
STUDIO 2 - OPEN & GLASS FRONTED	
923-751	Clear glass fuel effect upgrade
923-760	Black glass fuel effect upgrade
923-724	Red glass fuel effect upgrade**
STUDIO 3 - OPEN & GLASS FRONTED	
923-718	Clear glass fuel effect upgrade
923-706	Black glass fuel effect upgrade
923-739	Red glass fuel effect upgrade**



◊ The Glass Bead fuel options are available as a retro-fit solution to replace and enliven any White Stone Studio fires if desired.

** Please note: the red glass bead fuel effect transforms into a rich dark burgandy when the fire is on.

Studio Edge & Cool Wall Kits

Available for Glass Fronted Studio fires

Edge Kit

This kit is screw-mounted to the front flange of the outer firebox. The L-shaped attachments can either provide a 20mm return against which high temperature plasterboard/screed can be butted up for the 'clean edge' look or, if the firebox flange is on the outside of a brick or studwork wall, allow ceramic or stone tiles to be fixed with a similar look. The Edge Kit is finished in black to complement the Studio.

Cool Wall Kit

Again, screw-mounted to the front flange of the outer firebox, the 60mm deep U-shaped attachments of the Cool Wall kit are designed primarily for studwork false chimney breasts. The additional depth allows some of the heat to be vented up into the void above the firebox and then re-enter the room at a higher level. The effect is to produce a cooler wall immediately above the appliance than would otherwise be the case. The Cool Wall Kit is left unfinished so that it can be painted to match the front face of your fireplace.

Edge Kit

Installation method for:

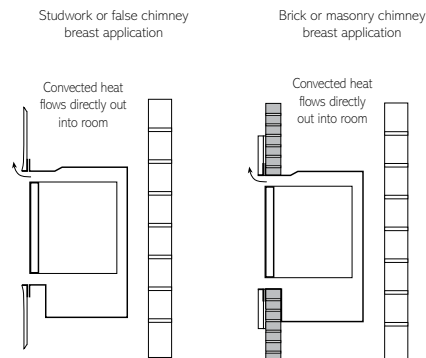

When using the Edge Kit the fire is recessed by 20mm from the finished wall surface and the kit is finished in black to complement the Studio.

NB: When using the Edge Kit, heat resistant board and high temperature finishing plaster must be used. Please refer to installation instructions for full details.

Cool Wall Kit

Installation method for:

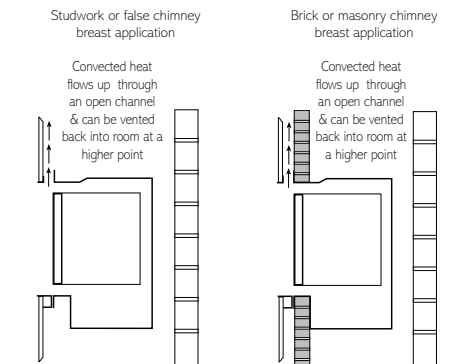

When using the Cool Wall Kit the fire is recessed by 60mm from the finished wall surface and the kit is left unfinished so that it can be painted to match your decor.

NB: Full installation information, including the requirement for the use of non-combustible materials, can be downloaded from www.gazco.com

Studio 22 Fires

FIRE INFORMATION

Product Code	Flue Type	Gas Type	Fuel Effect	Heat Input	Heat Output	Efficiency	Remote Control	Lining
⊗ 8704BFLEC	Balanced flue	Nat. Gas	Logs	7.50kW	5.85kW	78%	Prog. Thermostatic	Vermiculite
⊗ P8704BFLEC	Balanced flue	LPG	Logs	7.00kW	5.46kW	78%	Prog. Thermostatic	Vermiculite

STUDIO 22 DIMENSIONS (mm)

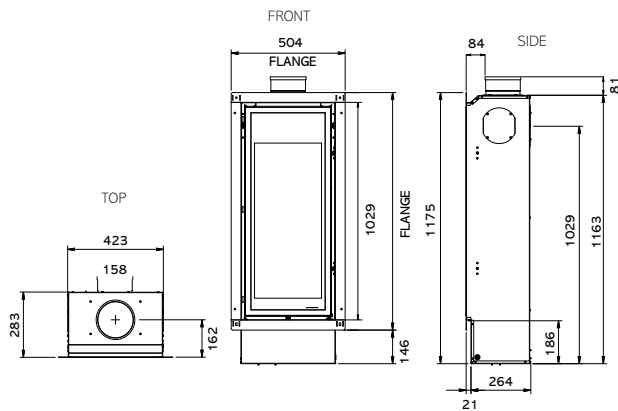

SORRENTO DIMENSIONS (mm)

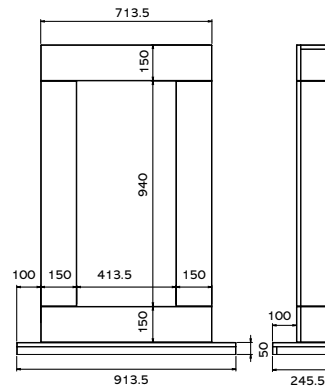

FRAME INFORMATION

Description	Frame Finish	Product Code	Frame Size (mm)		
			w	h	d
Bauhaus	Anthracite	8728BFAN22	524	1050	28
Bauhaus	Polished Stainless	8728BFSS22	524	1050	28
Profil	Anthracite	8726BFAN22	510	1036	13
Profil	Polished Stainless	8726BFSS22	510	1036	13
Steel 2	Graphite*	8729BFGP22	675	1320	13
Expression	Graphite*	923-786	614	1140	40
Verve	Graphite*	923-012	676	1320	51
Sorrento ^Δ	Natural Limestone	923-198	914	1290	246
Sorrento ^Δ	Graphite Granite	923-180	914	1290	246

Δ Where the Studio 22 is fitted with a Sorrento surround the fire may only be installed using the rear flue exit.

† For more Balanced Flue information and options please refer to our Concentric Flue System brochure which can be viewed or downloaded online at www.gazco.com

* A choice of 3 colours is available to choose from on Studio Profil & Bauhaus Anthracite Fronts & Steel 2, Expression Steel & Verve Graphite fronts (see pages 48-49), these are: Metallic Red, Metallic Blue, Metallic Bronze & Ivory. Please use the product code provided with the following suffix for your choice of colour: Metallic Red (RD), Metallic Bronze (BZ) & Ivory (IV) - for example: Studio 22 Glass Fronted Verve in Metallic Red = 923-012RD

Studio 1 Slimline Fires

FIRE INFORMATION

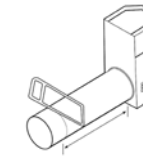

The Studio 1 Slimline comes complete with a specific rear exit balanced flue termination kit (8526SL) included.
395 x 200 x 200 mm (H x W x D)
Guard supplied. Cut to length as required on site.

Product Code	Flue Type	Gas Type	Fuel Effect	Heat Input	Heat Output	Efficiency	Remote Control	Lining
⊗ 123-022	Balanced flue	Nat. Gas	Logs	5.2kW	4.3kW	82%	Prog. Thermostatic	Vermiculite
⊗ 123-691	Balanced flue	LPG	Logs	5.1kW	4.2kW	82%	Prog. Thermostatic	Vermiculite
⊗ 123-126	Balanced flue	Nat. Gas	White Stones	5.2kW	4.3kW	82%	Prog. Thermostatic	Vermiculite
⊗ 123-756	Balanced flue	LPG	White Stones	5.1kW	4.2kW	82%	Prog. Thermostatic	Vermiculite
⊗ 123-169	Balanced flue	Nat. Gas	Logs	5.2kW	4.3kW	82%	Prog. Thermostatic	Black Reeded
⊗ 123-504	Balanced flue	LPG	Logs	5.1kW	4.2kW	82%	Prog. Thermostatic	Black Reeded
⊗ 123-375	Balanced flue	Nat. Gas	White Stones	5.2kW	4.3kW	82%	Prog. Thermostatic	Black Reeded
⊗ 123-460	Balanced flue	LPG	White Stones	5.1kW	4.2kW	82%	Prog. Thermostatic	Black Reeded
⊗ 123-353	Balanced flue	Nat. Gas	Logs	5.2kW	4.3kW	82%	Prog. Thermostatic	Brick Effect
⊗ 123-432	Balanced flue	LPG	Logs	5.1kW	4.2kW	82%	Prog. Thermostatic	Brick Effect
⊗ 123-266	Balanced flue	Nat. Gas	White Stones	5.2kW	4.3kW	82%	Prog. Thermostatic	Brick Effect
⊗ 123-497	Balanced flue	LPG	White Stones	5.1kW	4.2kW	82%	Prog. Thermostatic	Brick Effect

STUDIO 1 SLIMLINE DIMENSIONS (mm)

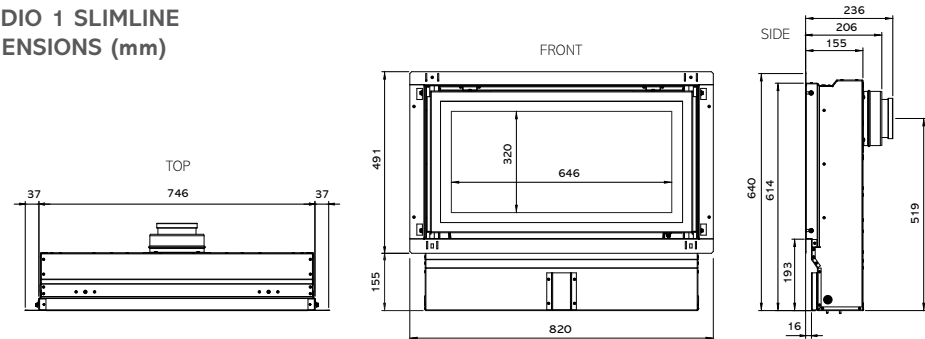

FRAME INFORMATION

Frame	Frame Finish	Product Code	Frame Size (mm)		
			w	h	d
Bauhaus	Anthracite	8711BFAN01	850	524	28
Bauhaus	Polished Stainless	8711BFSS01	850	524	28
Profil	Anthracite	8710BFAN01	836	510	13
Profil	Polished Stainless	8710BFSS01	836	510	13
Steel 2	Graphite*	923-883	1264	528	30
Expression	Graphite*	923-656	940	614	40
Verve	Graphite*	923-300	1264	528	56
Glass	Black Glass	923-628	1264	528	33.5

STUDIO 1 SLIMLINE OPTIONS

Product Code	Description
8727BFEK01	Edge fitting kit for BF †
8727BFCW01	Cool Wall fitting kit for BF †
923-733	Slimline - Vermiculite Lining Set ‡
923-826	Slimline - Black Reed Lining Set ‡
923-765	Slimline - Brick Effect Lining Set ‡
923-774	Clear glass fuel effect upgrade ◇
923-788	Black glass fuel effect upgrade ◇
923-792	Red glass fuel effect upgrade ◇
999-620	Remote system mains adaptor

◇ Available as a retro-fit solution to replace and enliven any White Stone Studio fires.

Please note: the red glass bead fuel effect transforms into a rich dark burgandy when the fire is on.

‡ Available as an upgrade to Studio fires with a log effect fuel bed

Studio 2 Duplex Fires

FIRE INFORMATION

Product Code	Flue Type	Gas Type	Fuel Effect	Heat Input	Heat Output	Efficiency	Remote Control	Lining
⊗ 123-319	Balanced flue	Nat. Gas	Logs	9.6kW	7.9kW	82%	Prog. Thermostatic	Vermiculite
⊗ 123-421	Balanced flue	LPG	Logs	9.3kW	7.6kW	82%	Prog. Thermostatic	Vermiculite
⊗ 123-329	Balanced flue	Nat. Gas	Logs	9.6kW	7.9kW	82%	Prog. Thermostatic	Black Reeded
⊗ 123-500	Balanced flue	LPG	Logs	9.3kW	7.6kW	82%	Prog. Thermostatic	Black Reeded

STUDIO 2 DUPLEX DIMENSIONS (mm)

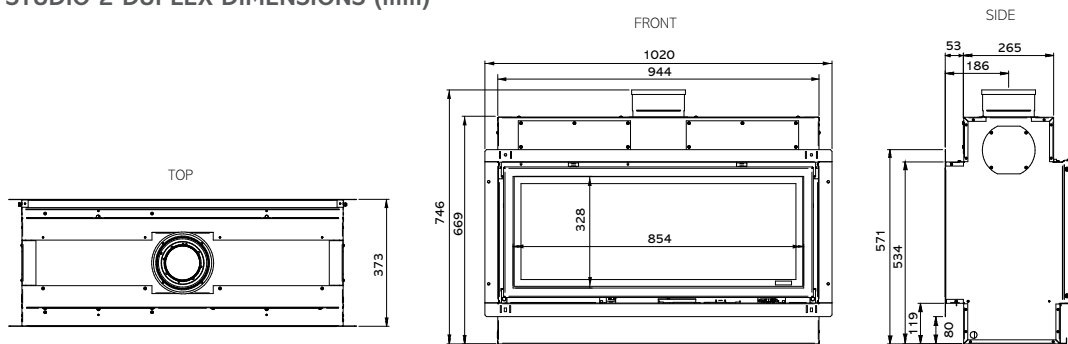

FRAME INFORMATION

Description	Frame Finish	Glass Fronted BF Product Code	Frame Size (mm)		
			w	h	d
Bauhaus	Anthracite	8718BFAN02	1050	524	28
Bauhaus	Polished Stainless Steel	8718BFSS02	1050	524	28
Profil	Anthracite	8717BFAN02	1036	510	13
Profil	Polished Stainless Steel	8717BFSS02	1036	510	13
Steel 2	Graphite	923-556	1500	528	30
Expression	Graphite	923-709	1140	614	40
Verve	Graphite	923-514	1500	528	56
Glass	Black Glass	923-535	1500	528	33.5

STUDIO 2 DUPLEX OPTIONS

Product Code	Description
8727BFEK02	Edge fitting kit for BF †
8727BFCW02	Cool Wall fitting kit for BF †
8572	Warm air ducting kit (2 outlets)
923-538	Duplex - Vermiculite Lining Set
923-696	Duplex - Black Reed Lining Set
8567	Balanced flue kit - up and out †
8524	Balanced flue kit - vertical †
999-201	Horizontal Exit terminal guard (required for below 2m) †
999-620	Remote system mains adaptor

† For more Balanced Flue information and options please refer to our Concentric Flue System brochure which can be viewed or downloaded online at www.gazco.com

A choice of 3 colours is available to choose from on Studio Profil & Bauhaus Anthracite Fronts & Steel 2, Expression Steel & Verve Graphite fronts (see pages 48-49), these are: Metallic Red, Metallic Bronze & Ivory. Please use the product code provided with the following suffix for your choice of colour: Metallic Red (RD), Metallic Bronze (BZ) & Ivory (IV)

- for example: Studio 2 Glass Fronted Verve in Metallic Red = 923-514RD

Eclipse 100 Fires

FIRE INFORMATION

Product Code	Flue Type	Gas Type	Fuel Effect	Heat Input	Heat Output	Efficiency	Remote Control	Lining
⊗ 128-041	Balanced flue	Nat. Gas	Logs	11.00kW	9.35kW	85%	Prog. Thermostatic	Ledgestone
⊗ 128-429	Balanced flue	LPG	Logs	10.80kW	9.18kW	85%	Prog. Thermostatic	Ledgestone
⊗ 128-030	Balanced flue	Nat. Gas	Logs	11.00kW	9.35kW	85%	Prog. Thermostatic	Black Reeded
⊗ 128-516	Balanced flue	LPG	Logs	10.80kW	9.18kW	85%	Prog. Thermostatic	Black Reeded

ECLIPSE DIMENSIONS (mm)

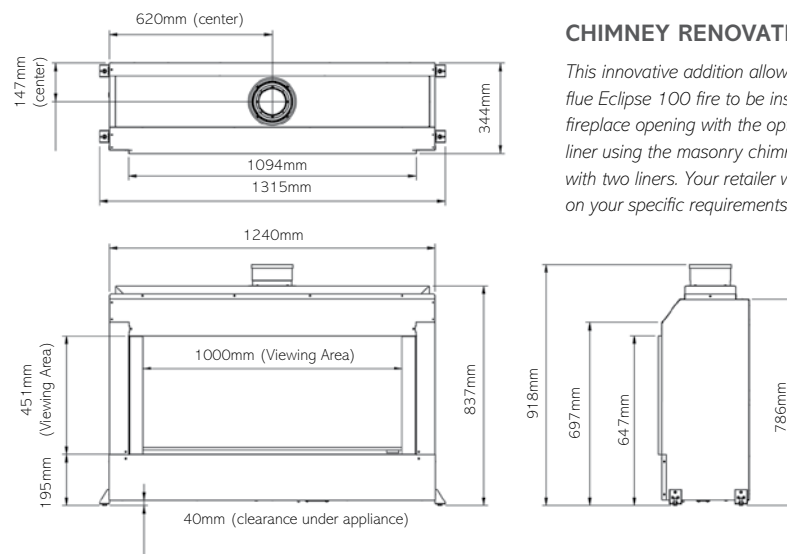

CHIMNEY RENOVATION KIT

This innovative addition allows your balanced flue Eclipse 100 fire to be installed in an existing fireplace opening with the option of either a single liner using the masonry chimney to bring in air or with two liners. Your retailer will be able to advise on your specific requirements.

FRAME INFORMATION

Description	Frame Finish	Product Code	Frame Size (mm)		
			w	h	d
Icon XS	Black Glass	928-172	1386	754	26
Verve XS	Graphite	928-090	1435	693	58
Expression	Graphite	928-023	1290	650	40

ECLIPSE OPTIONS

Product Code	Description
928-358	Eclipse Ledgestone-Effect Lining Set
928-279	Eclipse Black Reeded Lining Set
999-639	Battery Back-up Kit
999-117	Tiled Wall Fitting Kit
928-315	Chimney Renovation Kit

A choice of 3 colours is available to choose from on Eclipse Verve XS and Expression Steel frames, these are: Metallic Red, Metallic Bronze & Ivory. Please use the product code provided with the following suffix for your choice of colour: Metallic Red (RD), Metallic Bronze (BZ) & Ivory (IV)

- for example: Eclipse Verve XS in Metallic Red = 928-090RD

Riva2 500 Fires

FIRE INFORMATION

Product Code	Flue Type	Gas Type	Fuel Effect	Heat Input	Heat Output	Efficiency	Remote Control	Lining
⊗ 134-070	Conventional flue	Nat. Gas	Logs	6.4kW	4.8kW	75%	Prog. Thermostatic	Black Reeded
⊗ 134-796	Conventional flue	LPG	Logs	6.4kW	4.8kW	75%	Prog. Thermostatic	Black Reeded
⊗ 134-118	Conventional flue	Nat. Gas	Logs	6.4kW	4.8kW	75%	Prog. Thermostatic	Vermiculite
⊗ 134-784	Conventional flue	LPG	Logs	6.4kW	4.8kW	75%	Prog. Thermostatic	Vermiculite
⊗ 134-147	Conventional flue	Nat. Gas	Logs	6.4kW	4.8kW	75%	Prog. Thermostatic	Brick Effect
⊗ 134-756	Conventional flue	LPG	Logs	6.4kW	4.8kW	75%	Prog. Thermostatic	Brick Effect
⊗ 134-275	Balanced flue	Nat. Gas	Logs	5.8kW	4.8kW	82%	Prog. Thermostatic	Black Reeded
⊗ 134-447	Balanced flue	LPG	Logs	5.7kW	4.7kW	82%	Prog. Thermostatic	Black Reeded
⊗ 134-308	Balanced flue	Nat. Gas	Logs	5.8kW	4.8kW	82%	Prog. Thermostatic	Vermiculite
⊗ 134-516	Balanced flue	LPG	Logs	5.7kW	4.7kW	82%	Prog. Thermostatic	Vermiculite
⊗ 134-321	Balanced flue	Nat. Gas	Logs	5.8kW	4.8kW	82%	Prog. Thermostatic	Brick Effect
⊗ 134-583	Balanced flue	LPG	Logs	5.7kW	4.7kW	82%	Prog. Thermostatic	Brick Effect

RIVA2 500 DIMENSIONS (mm)

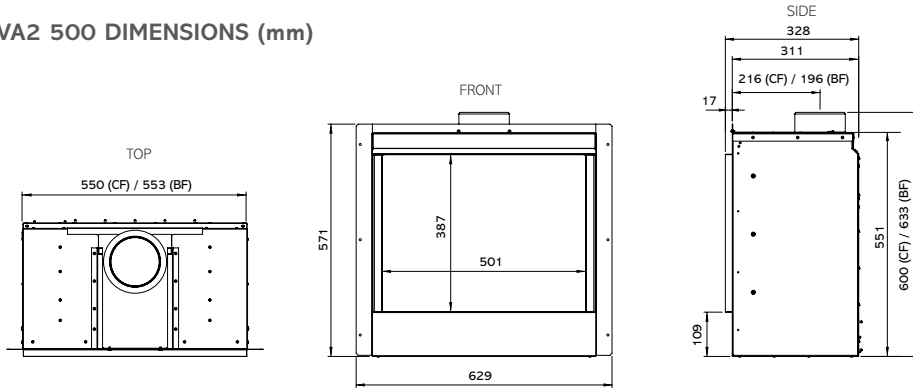

FRAME INFORMATION

Description	Frame Finish	Product Code	Frame Size (mm)		
			w	h	d
Icon XS	Black Glass	934-388	855	694	17
Verve XS	Graphite	934-033	890	621	57
Ellingham	Matt Black Cast Iron	934-470	885	678	75
Evoke Glass	Black Glass front/ Graphite rear	934-366	869	710	40
Evoke Glass	White Glass front/ Graphite rear	934-397	869	710	40
Evoke Steel	Graphite front and rear	934-330	869	710	40

RIVA2 500 OPTIONS

Product Code	Description
934-005	Black Reed Lining Set - Conventional Flue
934-021	Vermiculite Lining Set - Conventional Flue
934-030	Brick Effect Lining Set - Conventional Flue
934-159	Black Reed Lining Set - Balanced Flue
934-181	Vermiculite Lining Set - Balanced Flue
934-203	Black Reed Lining Set - Balanced Flue
999-620	Remote system mains adaptor
8572	Warm air ducting kit (2 outlets) - Bal. Fl
8509	Balanced flue kit - up and out †
8524	Balanced flue kit - vertical †
999-201	Horizontal Exit terminal guard (required for below 2m) †

† For more Balanced Flue information please refer to our Concentric Flue System brochure which can be viewed at www.gazco.com



Riva2 500 Ellingham with Black Reeded lining

Riva2 750HL Fires

FIRE INFORMATION

Product Code	Flue Type	Gas Type	Fuel Effect	Heat Input	Heat Output	Efficiency	Remote Control	Lining
134-089	Conventional flue	Nat. Gas	Logs	8.70kW	7.00kW	80%	Prog. Thermostatic	Black Reeded
134-489	Conventional flue	LPG	Logs	9.20kW	7.36kW	80%	Prog. Thermostatic	Black Reeded
134-113	Conventional flue	Nat. Gas	Logs	8.70kW	7.00kW	80%	Prog. Thermostatic	Fluted Vermiculite
134-501	Conventional flue	LPG	Logs	9.20kW	7.36kW	80%	Prog. Thermostatic	Fluted Vermiculite
134-139	Conventional flue	Nat. Gas	Logs	8.70kW	7.00kW	80%	Prog. Thermostatic	Brick Effect
134-528	Conventional flue	LPG	Logs	9.20kW	7.36kW	80%	Prog. Thermostatic	Brick Effect

RIVA2 750HL DIMENSIONS (mm)

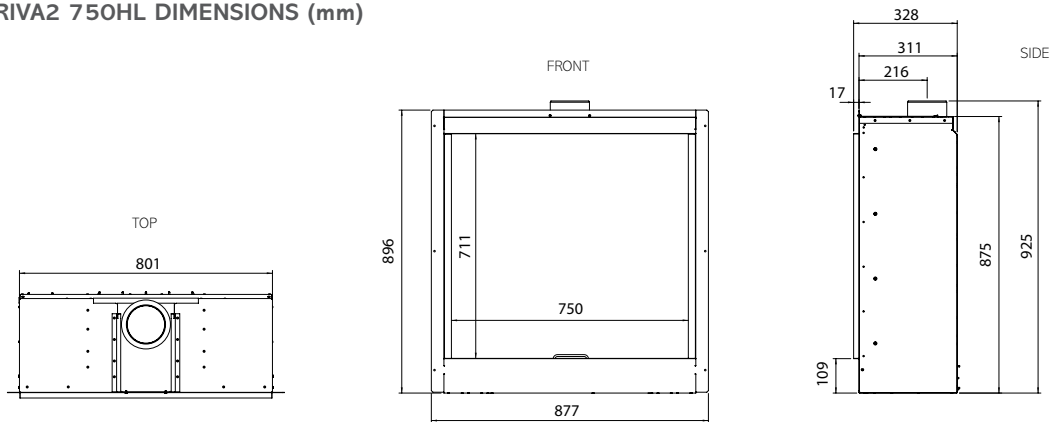

FRAME INFORMATION

Description	Frame Finish	Product Code	Frame Size (mm)		
			w	h	d
Verve XS*	Graphite	934-213	1202	1005	57
Evoke Glass*	Black Glass front and Graphite rear	934-245	1117	1034	42
Evoke Glass*	White Glass front and Graphite rear	934-264	1117	1034	42
Evoke Steel*	Graphite front and rear	934-281	1117	1034	42
Icon XS	Black Glass	934-371	1089	1015	17

RIVA2 750HL OPTIONS

Product Code	Description
934-011	Riva2 750HL CF Black Reeded Lining Set
934-053	Riva2 750HL CF Fluted Vermiculite Lining Set
934-060	Riva2 750HL CF Brick Effect Lining Set

* A choice of 3 colours is available to choose from on the Verve XS, front section of the Evoke Steel and the rear section of the Evoke Glass frames (see pages 70-74), these are: Metallic Red, Metallic Bronze & Ivory. Please use the product code provided with the following suffix for your choice of colour: Metallic Red (RD), Metallic Bronze (BZ) & Ivory (IV)

- for example: Riva2 750HL Evoke Glass in Black Glass with Metallic Red rear section = 923-245RD

Riva2 Stone Mantels

RIVA2 STONE MANTEL INFORMATION

Product Code	Description	Frame Finish	w	h	d
9002CLWM	Claremont (requires slip set)	Antique White Marble	1555	1143	190
9002CLTL	Claremont (requires slip set)	Limestone	1555	1143	190
9000CAWM	Cavendish Bolection (requires slip set)	Antique White Marble	1460	1320	207
9000CATL	Cavendish Bolection (requires slip set)	Limestone	1460	1320	207
9001GEWM	Georgian Roundel (requires slip set)	Antique White Marble	1460	1082	200
9001GETL	Georgian Roundel (requires slip set)	Limestone	1460	1082	200
9003GRWM	Grafton (requires slip set)	Antique White Marble	1415	1165	105
9003GRTL	Grafton (requires slip set)	Limestone	1415	1165	105
9004VIWM	Victorian Corbel (requires slip set)	Antique White Marble	1525	1170	250
9004VITL	Victorian Corbel (requires slip set)	Limestone	1525	1170	250
9005SAWM	Sandringham (requires slip set)	Antique White Marble	1550	1220	227
9005SATL	Sandringham (requires slip set)	Limestone	1550	1220	227

RIVA2 HEARTH INFORMATION

934-241	Small Hearth for Stone Mantel	Antique White Marble	1524	53	228
934-193	Small Hearth for Stone Mantel	Limestone	1524	53	228
934-489	Large Hearth for Stone Mantel	Antique White Marble	1625	53	457
934-351	Large Hearth for Stone Mantel	Limestone	1625	53	457

RIVA2 750HL SLIP SETS INFORMATION

934-790	Slip set for Riva2 750HL Stone Mantel	Antique White Marble	N/A	N/A	N/A
934-121	Slip set for Riva2 750HL Stone Mantel	Limestone	N/A	N/A	N/A

RIVA2 800 SLIP SETS INFORMATION

934-670	Slip set for Riva2 800 Stone Mantel	Antique White Marble	N/A	N/A	N/A
934-553	Slip set for Riva2 800 Stone Mantel	Limestone	N/A	N/A	N/A

Riva2 530 & 670 Fires

RIVA2 530 FIRE INFORMATION

Product Code	Flue Type	Gas Type	Fuel Effect	Heat Input	Heat Output	Efficiency	Remote Control	Lining	Opening Size (mm)		
									w	h	d
⊗ 134-156	Conventional	Nat. Gas	Logs	6.8kW	5.1kW	75%	Prog. Thermostatic	Black Reed	540	665	350
⊗ 134-739	Conventional	LPG	Logs	6.8kW	5.1kW	75%	Prog. Thermostatic	Black Reed	540	665	350
⊗ 134-171	Balanced	Nat. Gas	Logs	6.6kW	5.4kW	82%	Prog. Thermostatic	Black Reed	540	665	350
⊗ 134-718	Balanced	LPG	Logs	6.7kW	5.5kW	82%	Prog. Thermostatic	Black Reed	540	665	350
⊗ 134-189	Conventional	Nat. Gas	Logs	6.8kW	5.1kW	75%	Prog. Thermostatic	Vermiculite	540	665	350
⊗ 134-641	Conventional	LPG	Logs	6.8kW	5.1kW	75%	Prog. Thermostatic	Vermiculite	540	665	350
⊗ 134-215	Balanced	Nat. Gas	Logs	6.6kW	5.4kW	82%	Prog. Thermostatic	Vermiculite	540	665	350
⊗ 134-614	Balanced	LPG	Logs	6.7kW	5.5kW	82%	Prog. Thermostatic	Vermiculite	540	665	350
⊗ 134-233	Conventional	Nat. Gas	Logs	6.8kW	5.1kW	75%	Prog. Thermostatic	Brick Effect	540	665	350
⊗ 134-587	Conventional	LPG	Logs	6.8kW	5.1kW	75%	Prog. Thermostatic	Brick Effect	540	665	350
⊗ 134-256	Balanced	Nat. Gas	Logs	6.6kW	5.4kW	82%	Prog. Thermostatic	Brick Effect	540	665	350
⊗ 134-554	Balanced	LPG	Logs	6.7kW	5.5kW	82%	Prog. Thermostatic	Brick Effect	540	665	350

RIVA2 670 FIRE INFORMATION

⊗ 134-259	Conventional	Nat. Gas	Logs	6.8kW	5.1kW	75%	Prog. Thermostatic	Black Reed	670	530	350
⊗ 134-536	Conventional	LPG	Logs	6.7kW	5.0kW	75%	Prog. Thermostatic	Black Reed	670	530	350
⊗ 134-271	Balanced	Nat. Gas	Logs	6.7kW	5.5kW	82%	Prog. Thermostatic	Black Reed	670	530	350
⊗ 134-505	Balanced	LPG	Logs	6.8kW	5.6kW	82%	Prog. Thermostatic	Black Reed	670	530	350
⊗ 134-299	Conventional	Nat. Gas	Logs	6.8kW	5.1kW	75%	Prog. Thermostatic	Vermiculite	670	530	350
⊗ 134-472	Conventional	LPG	Logs	6.7kW	5.0kW	75%	Prog. Thermostatic	Vermiculite	670	530	350
⊗ 134-314	Balanced	Nat. Gas	Logs	6.7kW	5.5kW	82%	Prog. Thermostatic	Vermiculite	670	530	350
⊗ 134-455	Balanced	LPG	Logs	6.8kW	5.6kW	82%	Prog. Thermostatic	Vermiculite	670	530	350
⊗ 134-328	Conventional	Nat. Gas	Logs	6.8kW	5.1kW	75%	Prog. Thermostatic	Brick Effect	670	530	350
⊗ 134-426	Conventional	LPG	Logs	6.7kW	5.0kW	75%	Prog. Thermostatic	Brick Effect	670	530	350
⊗ 134-359	Balanced	Nat. Gas	Logs	6.7kW	5.5kW	82%	Prog. Thermostatic	Brick Effect	670	530	350
⊗ 134-410	Balanced	LPG	Logs	6.8kW	5.6kW	82%	Prog. Thermostatic	Brick Effect	670	530	350

RIVA2 530 FRAME INFORMATION

Description	Frame Finish	Product Code	Frame Size (mm)		
			w	h	d
Designio2 Steel	Graphite	934-187	610	704	38
Designio2 Steel	Iridium	934-187IR	610	704	38
Designio2 Glass	Black Glass	934-293	610	704	40
Evoke Steel*	Graphite	934-595	795	752	40
Evoke Glass*	Black Glass front with Graphite rear	934-417	795	752	40
Evoke Glass*	White Glass front with Graphite rear	934-476	795	752	40
Verve*	Graphite	934-441	690	835	59
Ellingham	Matt Black Cast Iron	934-433	815	759	75

RIVA2 670 FRAME INFORMATION

Description	Frame Finish	Product Code	Frame Size (mm)		
			w	h	d
Designio2 Steel	Graphite	934-238	735	569	38
Designio2 Steel	Iridium	934-238IR	735	569	38
Designio2 Glass	Black Glass	934-339	735	569	40
Evoke Steel*	Graphite	934-601	920	622	40
Evoke Glass*	Black Glass front with Graphite rear	934-529	920	622	40
Evoke Glass*	White Glass front with Graphite rear	934-558	920	622	40
Verve *	Graphite	934-156	1325	621	57
Verve XS*	Graphite	934-143	1000	621	56
Ellingham	Matt Black Cast Iron	934-486	940	627	75

*There is a choice of three colours to choose from on the Riva2 530 and Riva 670 **Evoke Glass, Evoke Steel, Verve and Verve XS** fronts (see pages 86-89), these are: Metallic Red, Metallic Bronze & Ivory. Please use the product code provided with the following suffix for your choice of colour: Metallic Red (RD), Metallic Bronze (BZ) & Ivory (IV) - for example: Riva2 530 Evoke Black Glass in Metallic Red = 923-417RD

RIVA2 530 DIMENSIONS (mm)

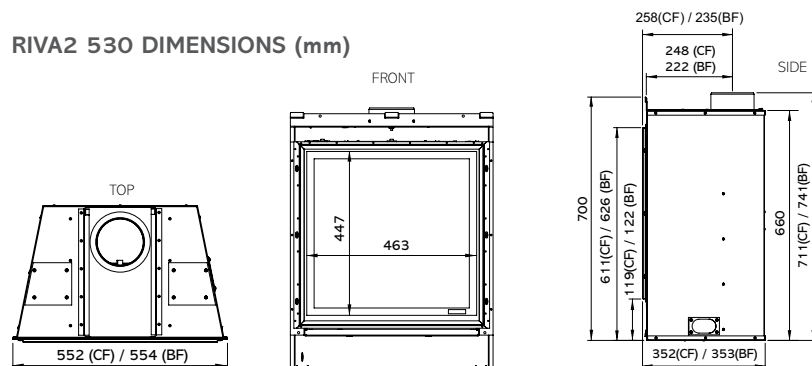

RIVA2 670 DIMENSIONS (mm)

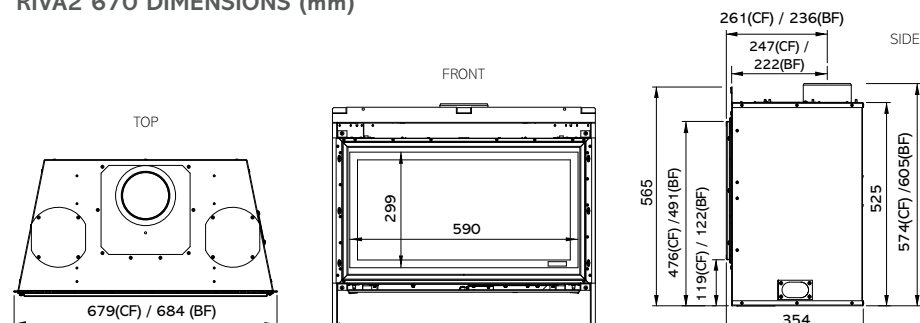

Riva2 530 & 670 Options

Product Code Description

8572	Warm Air Ducting Kit (2 outlets)
8524	Balanced Flue Kit - vertical (2x1000mm straight, 1x1000mm terminal)*
8509	Balanced Flue Kit - up and out (1x200mm straight, 1x500mm straight, 1 x 500mm terminal length, 1x90° bend)*
999-201	Horizontal Exit terminal guard (required for below 2m)
8736	Linerless kit for Riva2 530 and 670
999-620	Sequential system mains adaptor

RIVA2 530

934-049	Riva2 530 Conventional Flue Black Reed Lining Set
934-067	Riva2 530 Conventional Flue Vermiculite Lining Set
934-056	Riva2 530 Conventional Flue Brick Effect Lining Set
934-070	Riva2 530 Balanced Flue Black Reed Lining Set
934-088	Riva2 530 Balanced Flue Vermiculite Lining Set
934-074	Riva2 530 Balanced Flue Brick Effect Lining Set

RIVA2 670

934-096	Riva2 670 Conventional Flue Black Reed Lining Set
934-103	Riva2 670 Conventional Flue Vermiculite Lining Set
934-119	Riva2 670 Conventional Flue Brick Effect Lining Set
934-127	Riva2 670 Balanced Flue Black Reed Lining Set
934-111	Riva2 670 Balanced Flue Vermiculite Lining Set
934-137	Riva2 670 Balanced Flue Brick Effect Lining Set

*Additional flue pipe lengths and bends are available to extend the above kits

For more Balanced Flue information and options please refer to our Concentric Flue System brochure which can be viewed or downloaded online at www.gazco.com

ADDITIONAL INFORMATION FOR RIVA 530 AND RIVA 670

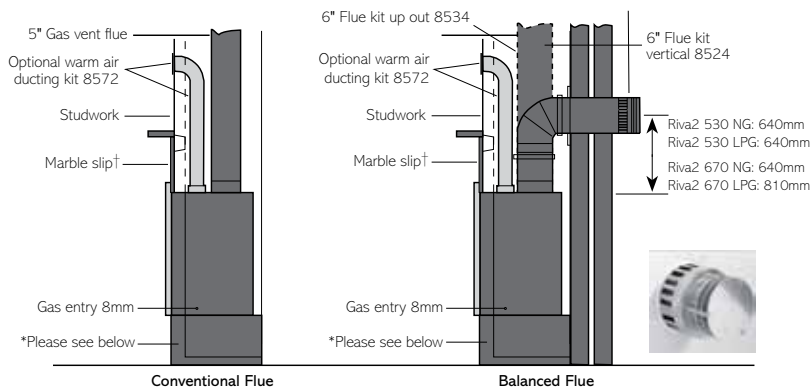

Diagrammatic representation only. Not accurate for installation purposes

NOTE: New 530 and 670 conventional flue connection system means easier installation.

No access to flue connector required during installation.

†A marble slip with a minimum width of 150mm is recommended around ALL installations. No combustible material, including

wallpaper, should be less than 150mm from the appliance.

*When installing below 150mm from the floor it is recommended that a 12mm thick non-combustible hearth is provided, extending 300mm in front and 150mm each side of the fire.

NOTE: Access to flue will be required during installation.

Riva2 800 Fires

RIVA2 800 FIRE INFORMATION

Product Code	Flue Type	Gas Type	Fuel Effect	Heat Input	Heat Output	Efficiency	Lining	Remote Control	Opening Size (mm)		
									w	h	d
⊗ 134-099	Balanced	Nat. Gas	Logs	9.50kW	7.98kW	84%	Vermiculite	Prog. Thermostatic	906	1105	391
⊗ 134-412	Balanced	LPG	Logs	8.80kW	7.39kW	84%	Vermiculite	Prog. Thermostatic	906	1105	391
⊗ 134-110	Balanced	Nat. Gas	Logs	9.50kW	7.98kW	84%	Black Reeded	Prog. Thermostatic	906	1105	391
⊗ 134-461	Balanced	LPG	Logs	8.80kW	7.39kW	84%	Black Reeded	Prog. Thermostatic	906	1105	391

RIVA2 800 DIMENSIONS (mm)

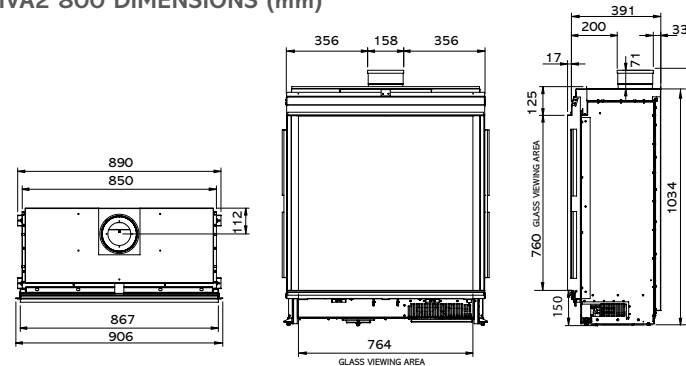

RIVA2 800 SORRENTO DIMENSIONS (mm)

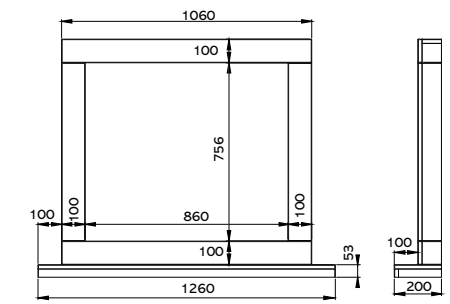

RIVA2 800 FRAME INFORMATION

Product Code	Description	Frame Finish	Frame Size (mm)		
			w	h	d
934-325	Icon XS	Black Glass	1263	1158	30
934-064	Sorrento	Natural Limestone	1260	1009	200
934-302	Sorrento	Graphite Granite	1260	1009	200
9002CLWM	Claremont (requires slip set)	Antique White Marble	1555	1143	190
9002CLTL	Claremont (requires slip set)	Limestone	1555	1143	190
9000CAWM	Cavendish Bolection (requires slip set)	Antique White Marble	1460	1320	207
9000CATL	Cavendish Bolection (requires slip set)	Limestone	1460	1320	207
9001GEWM	Georgian Roundel (requires slip set)	Antique White Marble	1460	1082	200
9001GETL	Georgian Roundel (requires slip set)	Limestone	1460	1082	200
9003GRWM	Grafton (requires slip set)	Antique White Marble	1415	1165	105
9003GRTL	Grafton (requires slip set)	Limestone	1415	1165	105
9004VIWM	Victorian Corbel (requires slip set)	Antique White Marble	1525	1170	250
9004VITL	Victorian Corbel (requires slip set)	Limestone	1525	1170	250
9005SAWM	Sandringham (requires slip set)	Antique White Marble	1550	1220	227
9005SATL	Sandringham (requires slip set)	Limestone	1550	1220	227
934-670	Slip set for Stone Mantel	Antique White Marble	N/A	N/A	N/A
934-553	Slip set for Stone Mantel	Limestone	N/A	N/A	N/A
934-241	Small Hearth for Stone Mantel	Antique White Marble	1524	53	228
934-193	Small Hearth for Stone Mantel	Limestone	1524	53	228
934-489	Large Hearth for Stone Mantel	Antique White Marble	1625	53	457
934-351	Large Hearth for Stone Mantel	Limestone	1625	53	457

RIVA2 800 OPTIONS

Product Code	Description
8534	Balanced flue kit - up and out (1x198mm straight, 1x500mm terminal length, 1x90° bend)*
8524	Balanced flue kit - vertical (2x1000mm straight, 1x1000mm terminal length*)
934-152	Riva2 800 Black Reed Lining Set
999-440	Riva2 800 Tiled Wall Fitting Kit
999-315	Chimney Renovation Kit (see page 128)
999-201	Horizontal Exit terminal guard (required for below 2m)
999-620	Remote System Mains Adaptor

*Additional flue pipe lengths and bends are available to extend the above kits

For more Balanced Flue information and options please refer to our Concentric Flue System brochure which can be viewed or downloaded online at www.gazco.com

Riva2 1050 Fires

RIVA2 1050 FIRE INFORMATION

Product Code	Flue Type	Gas Type	Fuel Effect	Heat Input	Heat Output	Efficiency	Remote Control	Lining	Opening Size (mm)		
									w	h	d
⊗ 134-136	Balanced	Nat. Gas	Logs	9.50kW	7.98kW	84%	Prog. Thermostatic	Vermiculite	1176	896	391
⊗ 134-493	Balanced	LPG	Logs	8.80kW	7.39kW	84%	Prog. Thermostatic	Vermiculite	1176	896	391
⊗ 134-178	Balanced	Nat. Gas	Logs	9.50kW	7.98kW	84%	Prog. Thermostatic	Black Reeded	1176	896	391
⊗ 134-544	Balanced	LPG	Logs	8.80kW	7.39kW	84%	Prog. Thermostatic	Black Reeded	1176	896	391

RIVA2 1050 DIMENSIONS (mm)

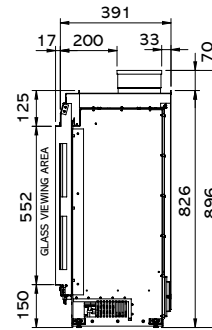
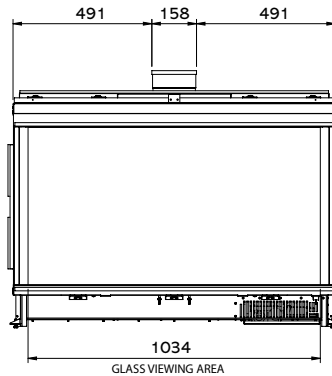
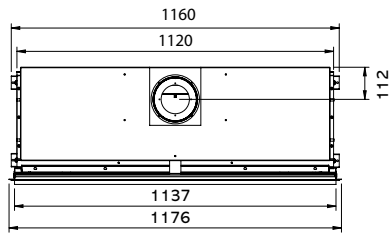

RIVA2 1050 SORRENTO DIMENSIONS (mm)

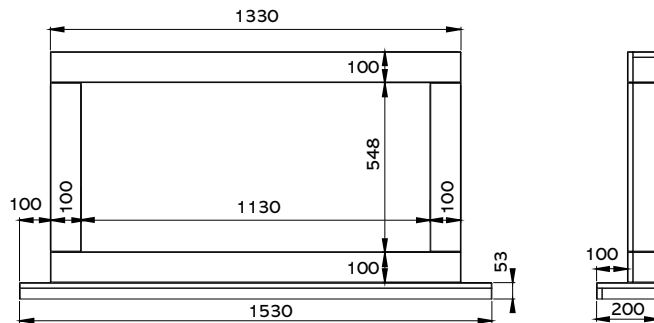

RIVA2 1050 FRAME INFORMATION

Product Code	Description	Frame Finish	Opening Size (mm)		
			w	h	d
934-501	Sorrento	Natural Limestone	1530	801	200
934-653	Sorrento	Graphite Granite	1530	801	200
934-334	Icon XS	Black Glass	1533	951	30

RIVA2 1050 OPTIONS

Product Code	Description
8523	Riva2 Balanced flue kit (1050 only) - up and out (1x500mm straight, 1x500mm terminal length, 1x90° bend)
8524	Balanced flue kit - vertical (2x1000mm straight, 1x1000mm terminal length*)
934-260	Riva2 1050 Black Reed Lining Set
999-321	Riva2 1050 Tiled Wall Fitting Kit
999-315	Chimney Renovation Kit
999-201	Horizontal Exit terminal guard (required for below 2m)
999-620	Remote System Mains Adaptor

*Additional flue pipe lengths and bends are available to extend the above kits

For more Balanced Flue information and options please refer to our Concentric Flue System brochure which can be viewed or downloaded online at www.gazco.com

RIVA2 800 & 1050 CHIMNEY RENOVATION KIT

This innovative addition allows your balanced flue Riva2 800 or 1050 fire to be installed in an existing fireplace opening with the option of either a single liner using the masonry chimney to bring in air or with two liners. Your retailer will be able to advise on your specific requirements.

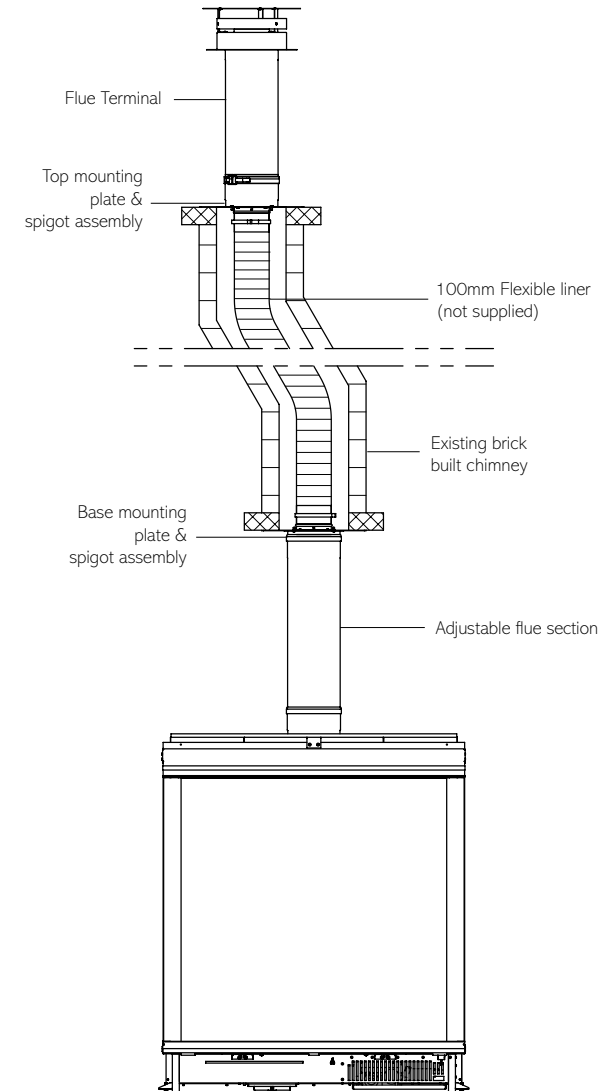

Balanced Flue Options

Gazco offers a comprehensive range of balanced flue system components. Please refer to our dedicated Concentric Flue System brochure which can be requested from your retailer or viewed online at www.gazco.com.

Vertical from the top of the appliance

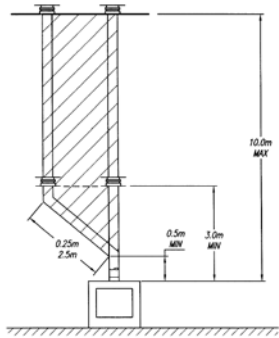

Vertical from the top of the appliance then horizontally out

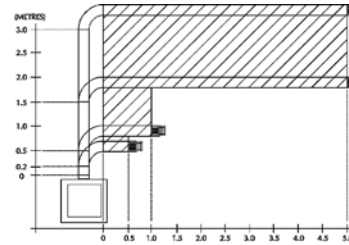

Riva2 800, Studio 1 & 22

Vertical from the top of the appliance then horizontally out - Studio 2 requires a minimum 700mm rise from the top of the unit

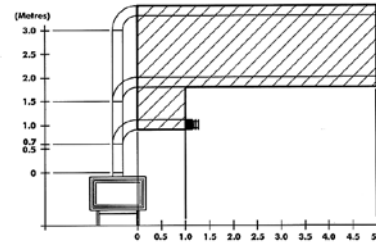

Studio 2

Vertical from the top of the appliance then horizontally out - Studio 3 requires a minimum 1000mm rise from the top of the unit

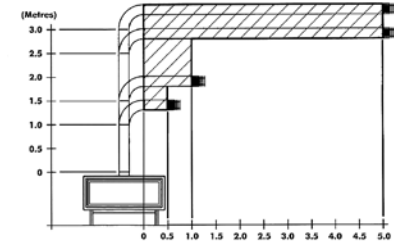

Studio 3

Vertical from the top of the appliance then horizontally out

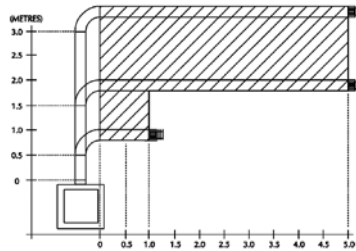

Riva2 530 Nat Gas/LPG & Riva2 670 Nat Gas

Vertical from the top of the appliance then horizontally out

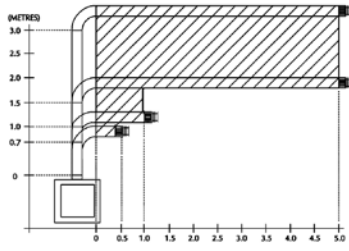

Riva2 670 LPG

Vertical from the top of the appliance then horizontally out

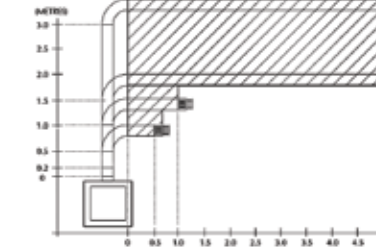

Riva2 500

Vertical from the top of the appliance then horizontally out

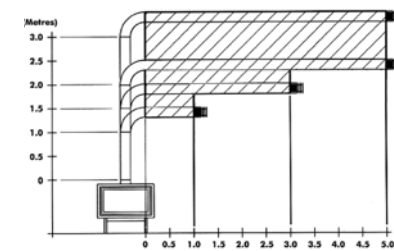

Studio 2 Duplex - Nat Gas

Vertical from the top of the appliance then horizontally out

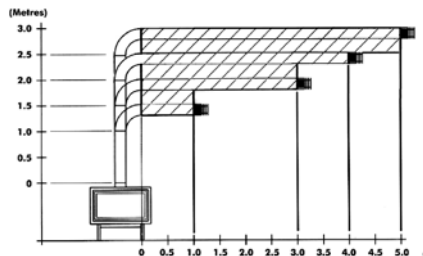

Studio 2 Duplex - LPG

Vertical from the top of the appliance then horizontally out

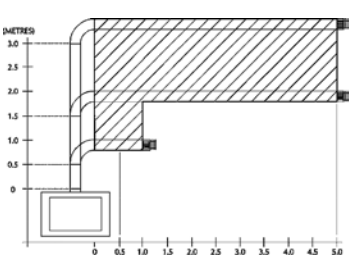

Riva2 1050 only

Vertical from the top of the appliance then horizontally out

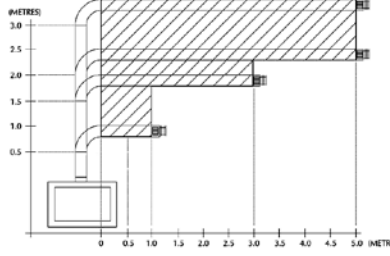

Eclipse 100 only

Command Remote Controls

Gazco was the first UK company to introduce remote controls for gas fires. Today, our Command remote control systems are supplied with many of the fires in this brochure:



Standard remote control for Open Fronted Studio fires

Allows you to ignite your fire and choose between different flame settings & heat outputs, all from the comfort of your sofa.



Programmable Thermostatic remote control for Glass fronted Studio, Eclipse & Riva2 fires

Allows remote operation of everything from ignition to extinguish as well as incorporating the benefits of a programmable timer & thermostat functions.

Important Information

Technical Specifications

All specifications given in this brochure are approximate. Actual specifications for each individual product will vary according to model. Your Gazco retailer will be pleased to provide any further information you require. Alternatively you may view or download specification sheets from www.gazco.com

Installation and Safety

Gazco gas fires must be fitted by a qualified gas installer (Gas Safe registered in the United Kingdom or Bord Gáis registered in the Republic of Ireland) who should also verify the proposed site conditions are fully suitable for the product selected. Complete installation instructions for many models can be obtained prior to purchase by viewing or downloading them from www.gazco.com. Please note that all parts of these fires, particularly the glass panel in the door, become extremely hot during operation and can result in serious injury and burns if touched. It is therefore recommended that a fireguard complying with BS 8423:2002 is used in the presence of young children, the elderly or infirm.

Colours/Flame pictures

Owing to variations in studio lighting and printing inks, the finishes/colours of fires illustrated in this brochure may differ slightly from actual models. Before purchasing, please ask your retailer to show you finish/colour samples. Whilst all the flame pictures shown in this brochure are of actual fires, flame pictures may vary depending on the installation, flue conditions and geographical/surrounding features that may effect the efficiency of the flue.

Care and maintenance

Traditional materials, such as polished steel and brass, tarnish on contact with air, especially when also exposed to heat. To help minimise this effect, we recommend fires receive regular treatment with suitable proprietary cleaners. Additionally, please remember that gas fires will require servicing annually by a qualified gas installer Gas Safe registered in the United Kingdom or Bord Gáis registered in the Republic of Ireland).

Warranty and Product Improvement



Your Gazco Expert Retailer will provide you with a Five Year Extended Warranty for your new gas fire, provided your fire has been registered with Gazco. The second and subsequent years are dependant on the appliance being serviced 12 months after installation and annually thereafter and exclude certain consumable parts. Fires purchased outside of Gazco's Expert Retailer Network will carry a standard 1 Year Warranty. Full warranty terms and conditions are available to view at www.gazco.com.

Gazco pursue a policy of continuous product improvement, therefore, whilst our products are correct at the time of the photography, we reserve the right to make alterations and amendments. Exact product details should be discussed with your retailer at the time of purchase.

Air Ventilation for Gas Fires

To comply with gas appliance installation regulations, all Studio 2 and 3 Open Fronted fires and all Glass Fronted Studio 2 fires with a conventional flue require additional ventilation into your room. For further information, please consult either your Gazco retailer or the Gazco Technical Information on our website www.gazco.com to confirm the ventilation required. Gazco offers suitable wall and floor vents that are available from your local retailer. To browse the range, please view our Fireplace, Stove and Hearth Accessories brochure available at www.gazco.com. All other fires featured in this brochure do not require additional ventilation.



Wall Vent
One size, choice of brass or stainless steel



Floor Vent
Two sizes, brass only







GAZCO
Fire Your Imagination