

*Stay on the
right track*



New Generation Features
Rubber Tracks for Excavators

A WORLD LEADER IN THE RUBBER INDUSTRY

Bridgestone was founded in 1931 and has grown to become the world's largest tire and rubber products company, with 179 production facilities in 25 countries and sales networks in over 150 countries.

The company is renowned for its R&D and design capability, exemplified by the success of Bridgestone's racing tires. This expertise extends to a wide range of products including automotive parts and industrial rubber products such as Rubber Tracks.

"Bridgestone... Serving Society with Superior Quality"

Bridgestone, Rubber Track Experts

It was Bridgestone engineers who pioneered the Rubber Track for excavators in the 1970's. Construction machinery manufacturers all over the world have adopted our Rubber Tracks on their machines. Bridgestone is the world's largest manufacturer of Rubber Tracks. By drawing on the group's extensive R&D, design and testing resources and combining this with our vast experience of tracked vehicles, Bridgestone Rubber Tracks for excavators meet the most demanding specifications in the industry.



Technology

Bridgestone Proving Ground

Bridgestone's state-of-the-art Rubber Track proving ground, located in Tochigi-Japan, ensures the highest integrity designs for Rubber Tracks and undercarriage systems. A variety of terrain conditions are maintained in order to establish consistency during the testing process.



Laboratory Bench Testing

Laboratory bench testing is vital to accelerate evaluation under controlled conditions. All Bridgestone Rubber Tracks are tested, evaluated, and proved.



FEM Analysis System

Bridgestone's scientifically proven non-linear, large-displacement FEM analysis system helps engineers to create innovative technologies.

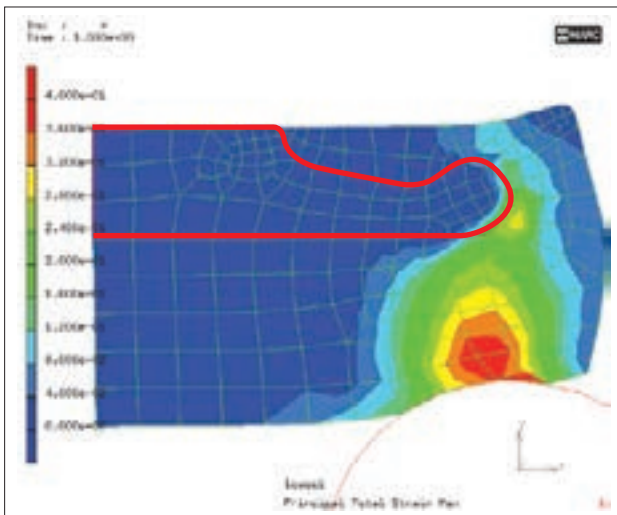

Product and Technical Assistance

Bridgestone evaluates in real-life environments and proves products by using actual machines in actual field conditions throughout the world for all Rubber Track applications.



New Features

Bridgestone continues to pioneer new technologies for Rubber Tracks. The following features are now available.



Pro-Edge Anti-edge cut



Tapered Core Metal Ride comfort



Interlocking Reduces De-tracking



Spiral Structure Anti-breakage steel cord

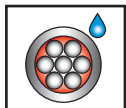

Anti-Rust Steel Cord Anti-deterioration

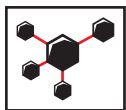

Anti-Cut Rubber Tread side durability

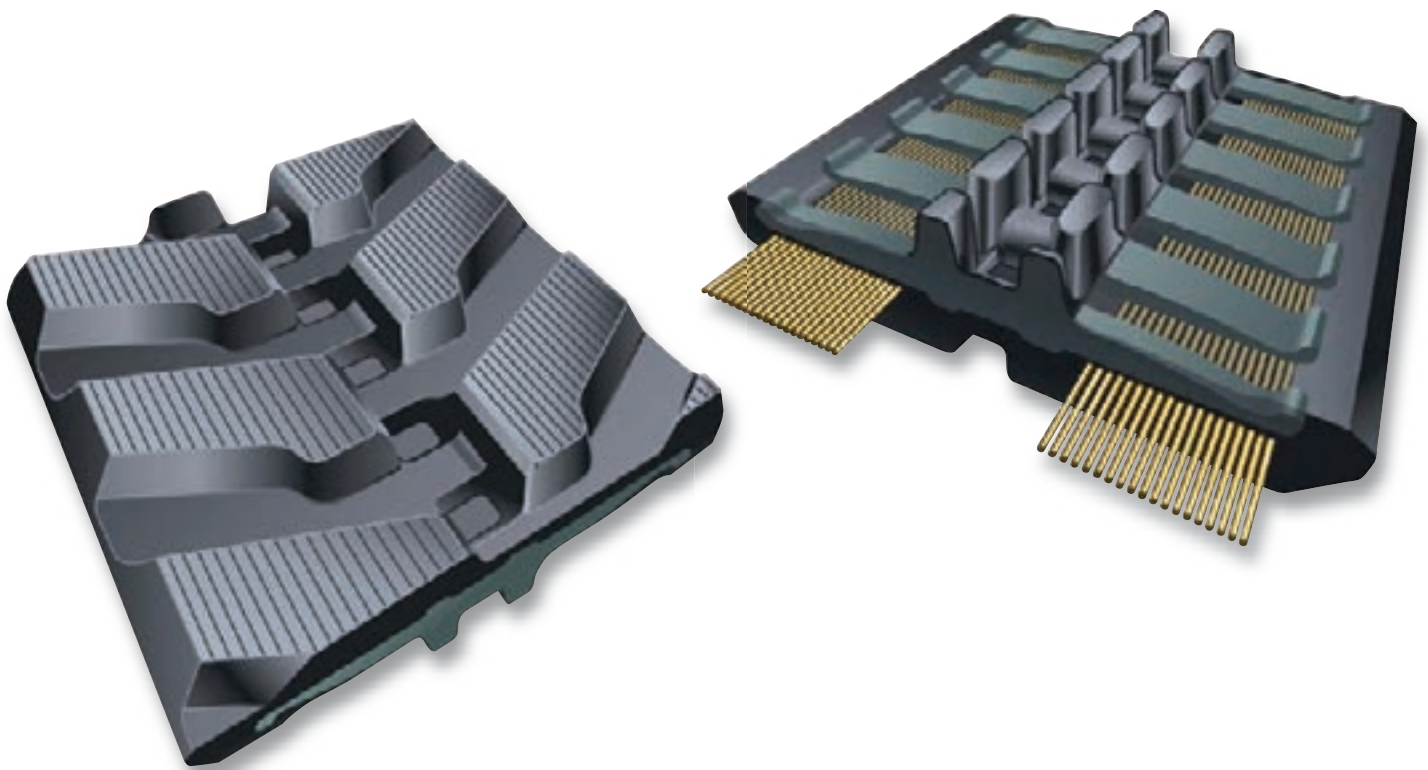



Pro-Edge

Problem

Edge-cut is a common type of damage for tracks used on construction sites. When a machine drives against a curb, stump or sharp/solid object, the edge of the track can bend over, shearing the rubber between the edge of the track and the tip of the embedded core metal.



Common cause of edge-cut



After 1000 hours



After 1900 hours

Solution

Bridgestone developed innovative Pro-Edge technology to minimize edge-cut damage. Pro-Edge technology is based on the combination of a rounded shape core metal edge design to avoid the build-up of stress concentrations, and additional rubber volume on both the inner and tread sides to make the track edge more durable.

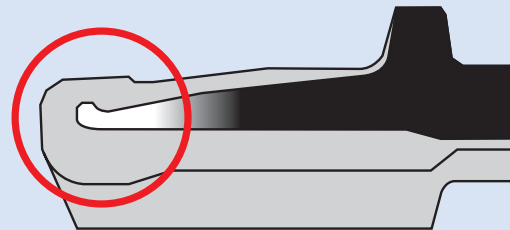

Patent No. EP0895924, US6106083



Pro-Edge

Tested and proven

Bridgestone's Pro-Edge technology is now well accepted by many customers and proved in the market. The benefits of Pro-Edge are also proved by Bridgestone's internal testing and by FEM analysis.

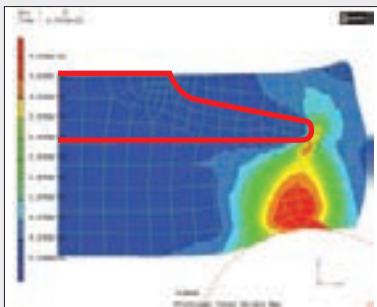

Standard core metal

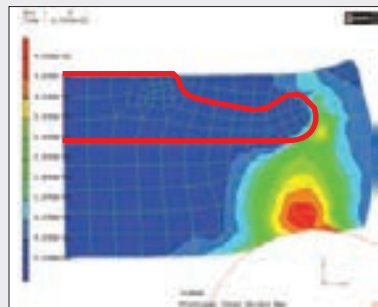

Pro-Edge core metal

47% less stress on the core metal edge compared to a standard core metal.

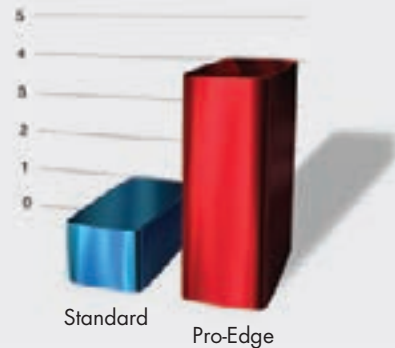

Standard

Pro-Edge

Pro-Edge 4-fold improvement

300mm width track testing data on 3.5ton machine. Graph shows the number of trials made before edge cut occurred.



Tapered Core Metal

Issue

Good ride comfort is of vital importance to the health and safety of machine operators. Low vibration is a key factor considered when selecting a machine and a rubber track. Some vibration is caused by the vertical movement of track rollers when dropping into the gaps between each core metal protrusion.

Track roller vertical movement

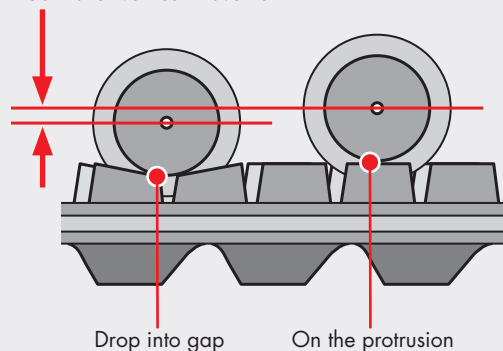

Solution

Bridgestone has reduced the vertical movement of the track rollers by adopting an advanced tapered protrusion technology. The tapered shape of the running surface of the protrusion optimizes the roller path against the natural rotation of the core metal under vertical load. This results in good ride comfort without the need of additional material. Avoiding the use of additional material is in line with Bridgestone's environmental policy.

Reduced track roller vertical movement

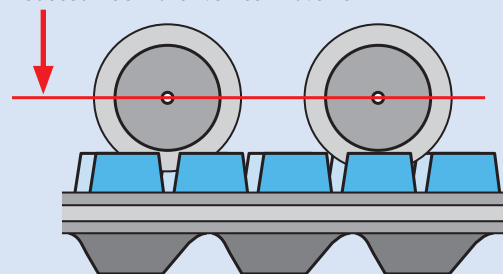

Tapered Core Metal

FEM analysis result: Track roller vertical movement



Conventional protrusion

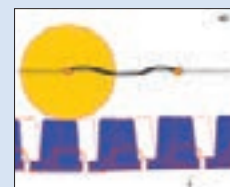

Tapered protrusion

Tested and proven

Data obtained by FEM analysis and field testing clearly shows a reduction in vibration using tapered core metals. This brings greater ride comfort to the operator.

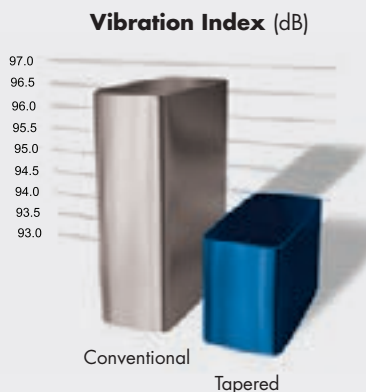

Testing carried out at Bridgestone's proving ground in Tochigi Japan using 5.3ton machine on asphalt.

Interlocking

Problem

De-tracking is when a track partially removes itself from the undercarriage during operations by disengaging from one of the components such as the sprocket, idler or rollers. This causes down-time and can lead to failure by fatal breakage.



De-tracking at sprocket



De-tracking at track roller



Steel cord breakage caused by de-tracking

Solution

Bridgestone uses an interlocking design to reduce de-tracking. By interlocking adjacent core metals the track benefits from more lateral stiffness. Both single and double interlocking systems are available.

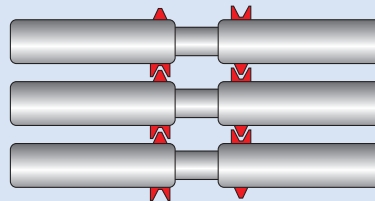

Double engaged interlocking

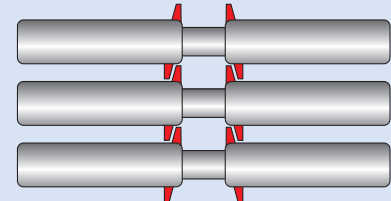

Single engaged interlocking



Interlocking

Tested and proven

Interlocking technologies have become common features in Bridgestone short pitch tracks. Positive market feedback, successful supply history and Bridgestone's internal testing all confirm the benefits of interlocking technologies.

The following testing was carried out at Bridgestone's proving ground in Tochigi Japan. Even in loose tension conditions (sag=45mm) interlocking tracks did not de-track.

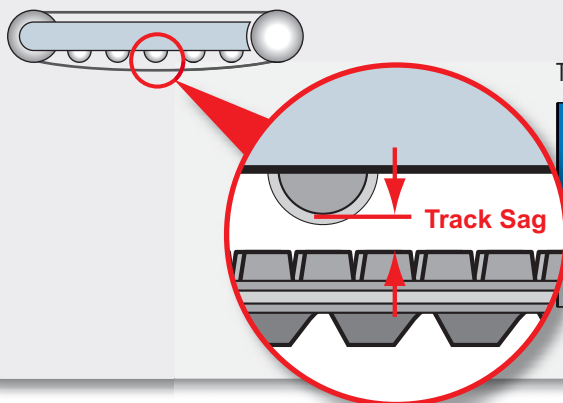

Test data from 5.3ton machine, 10 trials against fixed rock.

Tension	Track sag	De-tracking occurrence	
		Interlocking	Non-Interlocking
Normal	15mm	Zero	6
Loose	30mm	Zero	10
Very Loose	45mm	Zero	10



Spiral Structure

Problem

The majority of Rubber Tracks utilize a traditional overlap type structure of steel cord. When the track is under abnormal stress such as excessive tension, failure often occurs at the ends of the overlap area. This is expected due to the inferior uniformity in the circumferential steel cord structure.



Steel cord breakage at end of overlap

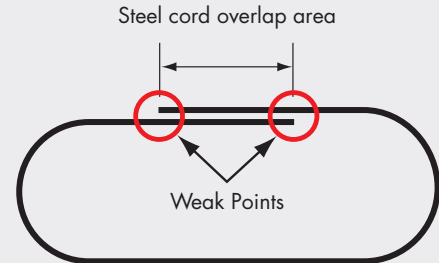

Solution

Bridgestone has developed a spiral steel cord structure which is now a technology commonly used in Bridgestone tracks used on Compact Track Loaders. This technology is now being expanded into excavator tracks. Spiral steel cord technology offers complete uniformity of tensile strength around the circumference of the track. In addition to even tension, an even distribution of traction minimizes the risk of track breakage.

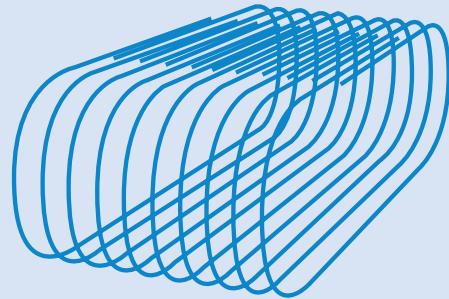

Overlap joint structure



Spiral Structure

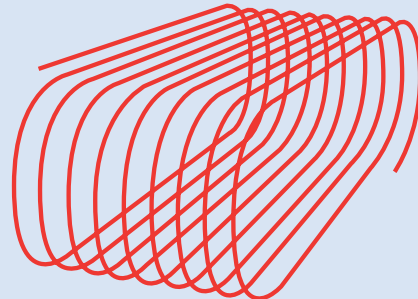

Spiral structure

Market Feedback

Field survey data collected by Bridgestone engineers indicates that 30-40% of all track failures are linked to steel cord breakage at the overlap area.

In response to this, Bridgestone developed **"Tough Track"** for excavators utilizing spiral steel cord and other technologies pioneered for Compact Track Loader tracks.

Field survey data and market feedback confirms a significant reduction in steel cord breakage of tracks with spiral technology. Therefore spiral tracks offer enhanced reliability, longer life and lower running costs.



Anti-Rust Steel Cord

Problem

Once deep external cuts, chunking and edge cut have occurred, the danger of water and mud penetrating the rubber track is greatly increased. Moisture attacks the embedded steel cord. Depending on the severity of the damage and working conditions, the tensile strength of rusted steel cords weakens and can lead to breakage.



Steel cord deterioration caused by rust

Solution

Thanks to Bridgestone's world leading tire technology, our engineers have developed an advanced Anti-Rust Steel cord which minimizes deterioration caused by rust.

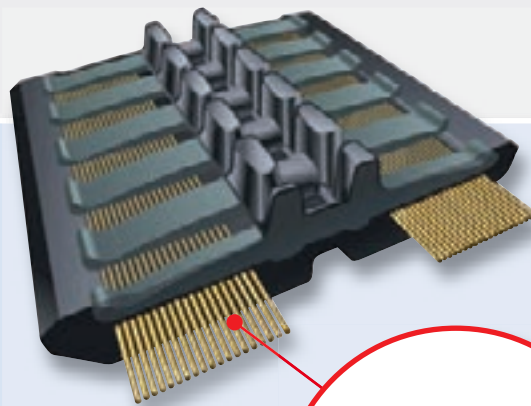

Even when moisture/mud penetrates from external cuts, steel cord tensile strength is maintained for longer.

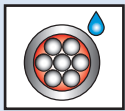

Anti-Rust Steel Cord

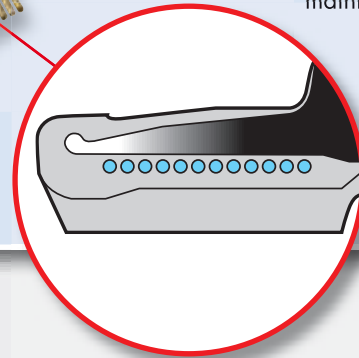

Tested and proven

Salt bath testing carried out over 7 days has proved over 41% improvement in performance compared with standard steel cord.

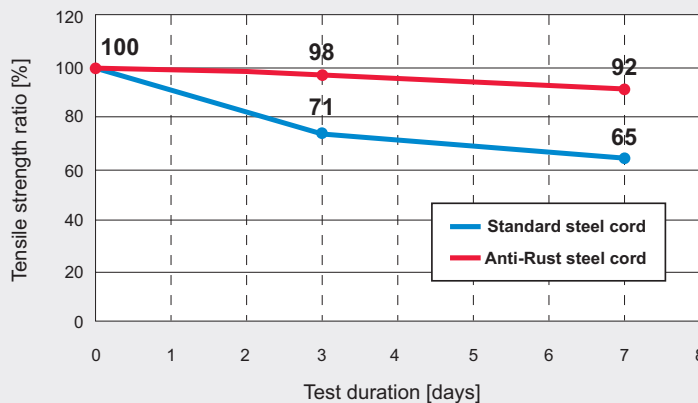

Anti-Rust Steel cord deterioration performance



Anti-Cut Rubber

Problem

Harsh working conditions are normal for excavator operations. Such conditions cause external cuts and chunking to the tread rubber. Moisture and mud can penetrate from external cuts, causing internal steel parts to progressively weaken. This can lead to fatal failure such as steel cord breakage.



External cut



Rubber chunking

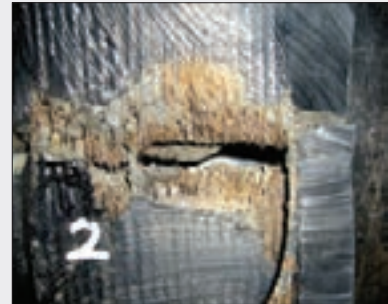

Steel cord breakage caused by rust

Solution

The development of high quality rubber compounds is one of Bridgestone's core competencies. Bridgestone has developed an Anti-Cut Rubber compound which significantly minimizes the cut damage and chunking caused by sharp objects. This increases the life of the track by reducing premature breakage.

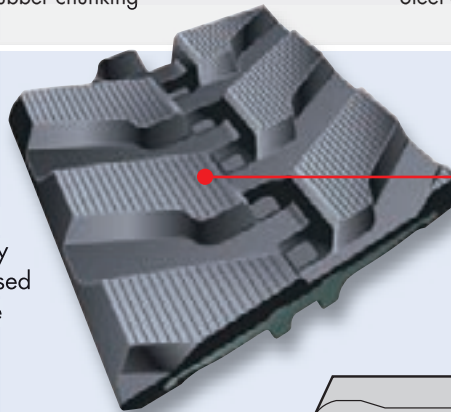

Tread side is made of an Anti-Cut Rubber compound.

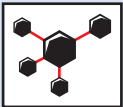
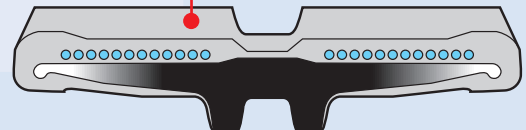

Anti-Cut Rubber

Tested and proven

Test data shows reduced occurrences of cut damage and chunking. The photos below compare the track condition after 140hrs of continuous tracking using a 3.5ton machine at Bridgestone's proving ground.



Before testing



Conventional rubber compound



Bridgestone Anti-Cut rubber compound

Stay on the Right Track

The long standing superior quality of Bridgestone tracks has been a well established fact in the OEM and replacement markets for many years.



Track size indication

Track size is indicated by a size numbering system consisting of 5 elements. This part number is normally vulcanized on the inner surface of the track.

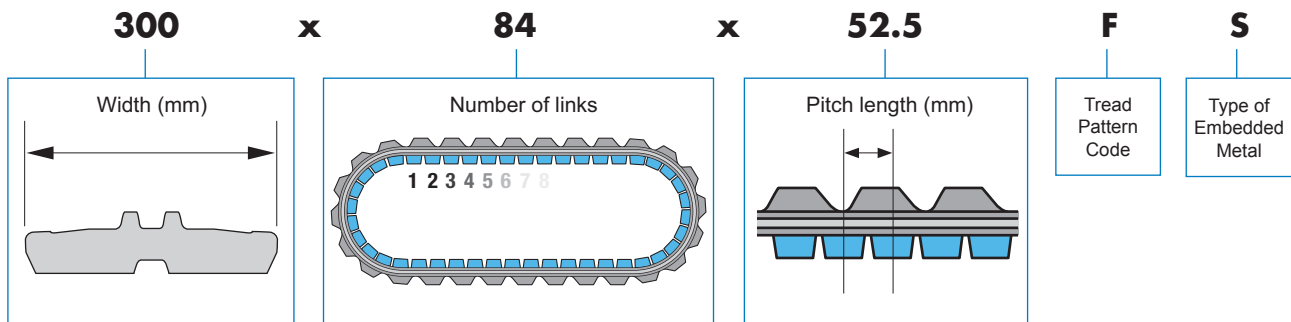

How to get the most out of your Rubber Tracks

Bridgestone utilises its experience to design and test Rubber Tracks for superior performance. But to get the most out of your Rubber Tracks, you must treat them with care. We recommend the following basic guidelines in this respect:

- 1** It is essential to maintain the correct tension on your tracks at all times. Check your vehicle operating manual for details.
- 2** Periodically check the undercarriage components (i.e. sprocket, rollers and idler) for wear. Wear and damage of the undercarriage components can affect track performance and durability.
- 3** Limit the use of your vehicle on large, sharp rocky surfaces and sharp steel edges.
- 4** Avoid fast sharp turns and side slope turns.
- 5** Prevent large foreign objects from becoming entangled in your undercarriage.
- 6** Do not drive with track sidewall edges pressing against hard walls, curbs and other objects.
- 7** If oil or a similar product gets on the track, it should be removed. Over time, oil will degrade the rubber quality.
- 8** When storing your vehicle for a period of time, it should be kept indoors away from rain and direct sunlight in order to prolong the life of the Rubber Tracks.



The information contained in this publication is for guidance purposes only. While every effort has been made in its production, no responsibility can be accepted for any loss or damage arising from any undetected error. Any data supplied is subject to possible revision following the date of publication. Produced January 2009.

Sales Companies:

Bridgestone Industrial Ltd.
CP House, 97-107 Uxbridge Road
Ealing, London W5 5TL, UK
Tel: +44 20 8567 8080
Fax: +44 20 8567 2066

Bridgestone Industrial Products America Inc.
402 Bna Drive, Suite 212
Nashville, TN 37217, USA
Tel: +1 615 365 0600
Fax: +1 615 365 9946

Bridgestone Engineered Products of Asia Sdn. Bhd. (364273M)
L1-E-3B, Enterprise 4, Technology Park Malaysia
Lebuhraya Puchong-Sg Besi, Bukit Jalil,
57000 Kuala Lumpur, Malaysia
Tel: +60 3 89962670
Fax: +60 3 89962690

Published by:

Bridgestone Corporation
Yaesu Centre Building, 10F, 1-6-6, Yaesu
Chuo-ku, Tokyo 103-0028 Japan
Tel: +81 3 5202 6853
Fax: +81 3 5202 6856

