

## ASL SERIES STANDARD PRESSURE TRANSDUCER

The ASL Series of Standard Pressure Transducers have been designed for the detection of fluid and air pressures in demanding motorsport and automotive applications; ideal for high precision data acquisition or control systems. These transducers can also be installed directly onto vehicles, as part of a test stand or dyno.

Offering a high level of reliability and endurance the ASL is protected against the high vibration, shock and high temperatures found in motorsport. With a modular construction and programmable amplifier, this provides a fast delivery time for standard and custom configurations.

Pressure ranges are available between 1 to 400 Bar in either Absolute, Gauge or Sealed Gauge reference.

Industry standard 3-wire electrical connections allow configuration with most common ECU's and data logging systems.

The ASL Series are race proven in many formula around the world; offering a cost effective solution for professional engineers.

## TECHNICAL SPECIFICATIONS

<b>Pressure Reference</b>	Absolute, Gauge and Sealed Gauge
<b>Standard Pressure Ranges (Bar)</b>	1, 5, 10, 20, 35, 50, 100, 200, 400
<b>Proof Pressure (Over range)</b>	150% of Range
<b>Burst Pressure</b>	>300% of Range
<b>Accuracy</b>	±0.5% FS Combined Linearity & Hysteresis (CNLH)
<b>Thermal Accuracy</b>	Zero ±0.04% FS/°C (Sensitivity ±0.04% of Reading /°C)
<b>Output</b>	0.5V to 4.5V (±0.5%)
<b>Supply</b>	5V (±0.5V) Ratiometric or 8-16Vdc
<b>Operating Temperature Range</b>	-20°C to +135°C
<b>Compensated Temperature Range</b>	0°C to +125°C
<b>Construction</b>	Alumina, EPDM, Stainless Steel and Viton
<b>Electrical Connection</b>	50cm 26AWG, FEP Insulated Screened Cable
<b>Process Connection (Thread Size)</b>	Please see Part Number Configurator
<b>Protection Class</b>	IP67
<b>EMC Protection &amp; Vibration</b>	EN E50082-1 and Mil-Std-810C, Curve L, 20G
<b>Weight</b>	34g
<b>Options</b>	Cable Spec, Connector Fitted, Thread Size & Labelling

KA Sensors adopts a continuous development program which sometimes necessitates specification changes without notice.

## Sensors For Motorsport

### Features

- Compact Design
- 1 to 400 Bar Range
- Amplified Output
- Rugged Design
- ±0.5% Accuracy

### Applications

- Coolant
- Brakes
- Water
- Boost
- Fuel
- Oil

kasensors.com

sales@kasensors.com

+44(0)1476 568057

ASL 10.18

# PART NUMBER CONFIGURATOR

Pressure Reference

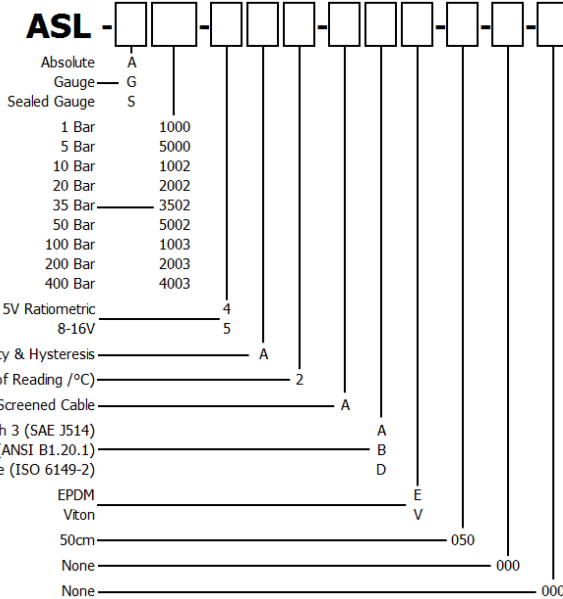

The KA configuration tool is used to specify a standard KA Sensor, other options are available.

*Sense  
Analyse  
Control*

Services for:

- Data Logging
- Telemetry
- Controls
- Wiring

## MECHANICAL DETAILS

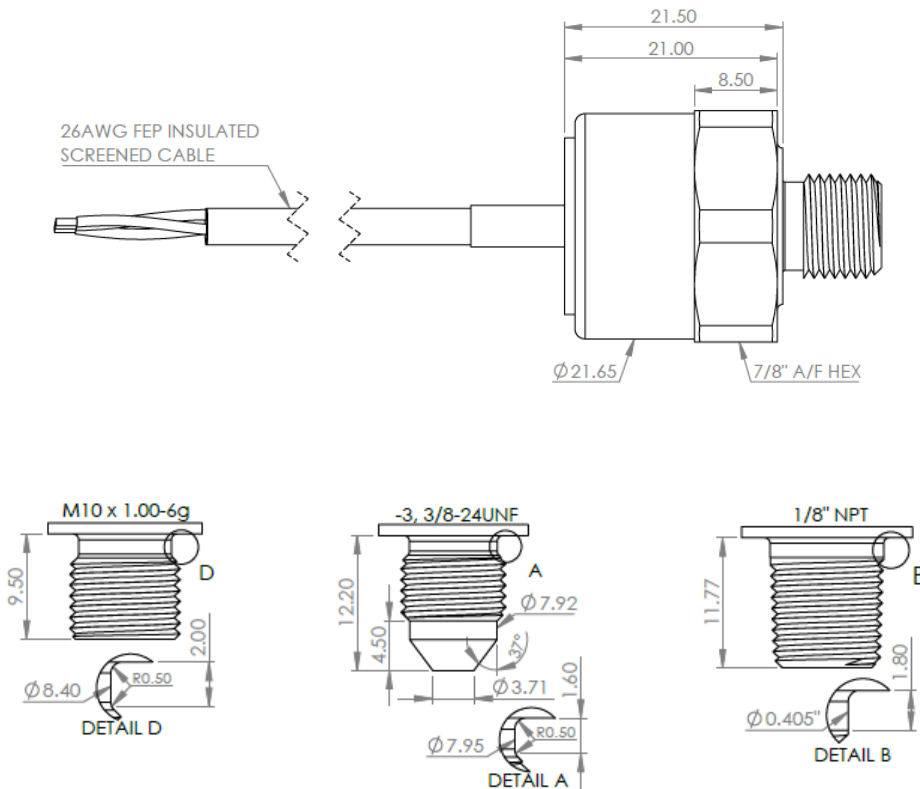

## CONNECTION DETAILS

+Ve Supply	0V Supply	Signal
Red	Blue	Yellow

kasensors.com  
sales@kasensors.com  
+44(0)1476 568057

ASL 10.18