



ASCENDANT
ACCESS

Operating Manual

A18-13TJ ISS02

ASCENDANT ACCESS
Unit 5 Earls Park North
Earlsway
Team Valley Trading Estate
Gateshead
Tyne and Wear.
NE11 0RQ
England

Tel: 0191 4879933

CONTENTS OF MANUAL

SECTION 1 - GENERAL DESCRIPTION.....	1
SECTION 2 - SAFETY.....	5
2.1 GENERAL SAFETY COMMENTS	7
2.2 WARNINGS.....	8
2.3 MAXIMUM WIND SPEED	9
SECTION 3 - OPERATOR GUIDE	10
3.1 SAFETY.....	10
3.2 PRE-START CHECKS.....	10
3.3 SETTING UP	11
3.4 OPERATING THE PLATFORM.....	13
3.5 EMERGENCY CONTROLS.....	15
3.6 STOWING	16
SECTION 4 - MAINTENANCE.....	17
4.1 GENERAL	17
4.2 MAINTENANCE AND LUBRICATION SCHEDULE.....	17
4.3 GENERAL MAINTENANCE	18
4.4 A18-13 SERVICE SCHEDULE	18
4.5 SAFETY CHECKS ON PLATFORM CONTROL CIRCUIT	22
4.6 LUBRICATION DIAGRAM.....	24
4.7 SIX MONTHLY INSPECTION SCHEDULE	25
SECTION 5 - TROUBLE SHOOTING.....	28
SECTION 6 - INSPECTION RECORDS	29

SECTION 1

TECHNICAL SPECIFICATION

ASCENDANT A18-13TJ TRUCK MOUNT

GENERAL

This is our multi-purpose 18m maximum working height access platform mounted onto a RENAULT MAXICITY/ NISSAN CABSTAR of 3,500kg GVW and 3400mm wheel-base.

The telescopic boom plus fly arrangement gives excellent controllability when manoeuvring. The multiple jacking configurations ensure the machine can be set up for working in the most confined spaces.

The design concept includes for oversized structural elements coupled to sensitive, electro-hydraulic proportional controls ,making the machine feel safer and simpler than its contemporaries when being operated whilst requiring the minimum of maintenance.

The unit is generally as shown on our attached drawings but specifically as described below:

PERFORMANCE

SWL	230kg
Max working height	18m
Max platform height	16m
Max. working outreach	13m
Cage dimensions	0.73m x 1.4m x 1.1m high
Cage rotate	160 deg.
Closed height	3.0m
Closed width	2.3m
Travelling length	7.0m
Weight of unit	3330kg including vehicle (approx.)

CAGE

Formed from structural quality aluminium tubes the top rail is set back from the front of the cage providing finger protection and also presenting a flush face for the cage easing the problems associated with carrying large, flat objects e.g. overhead signs.

Having an uninterrupted plan area of 0.73m x 1.4m the assembly is suitable for 2 men and tools for working.

The cage features a 150mm high kickboard and a mesh floor.

160 degrees powered rotation fitted as standard.

BOOMS

A three stage telescopic main boom coupled to an independent fly boom forms the general concept of this particular unit.

The main boom is driven in and out via a single telescope cylinder and system of wire ropes.

The fly boom is 2.0m long and has an operating arc of 125 deg.

Cage leveling is effected via a closed loop master/slave hydraulic cylinder arrangement complete with a manual trimming valve.

The boom sections are formed from prefabricated folded sections seam welded together to produce a 6 sided box.

TURRET

Two substantial prefabricated box sections form the upright portion of this assembly giving the platform substantial lateral rigidity. An oversized pin sits between the booms and the turret. A large slewing ring, driven by a hydraulic planetary gearbox and pinion connects this unit to the chassis.

CHASSIS

Formed into a box from deep folded channels, this unit features high torsional resistance combined with lightweight. Powered horizontal and vertical jacks are incorporated along with a none-slip deck.

An "A" frame mounted behind the cage provides a stowing point for the booms during transport.

Steps are provided for easy access to the vehicle deck.

Legally proportioned side guards are included between the vehicle's wheels.

CONTROLS

The machine is fitted with H-type jacks that are controlled from the lower floor position. The jacks are fail-safe in principle preventing the platform from operating unless all 4 are in firm contact with the supporting surface.

Cage controls of the electro hydraulic proportional type, duplicated at the base, give very smooth control of the platform throughout its operating range.

The platform will automatically default to the appropriate working envelope as the jacks are deployed. All limiting devices are positively failsafe in operation.

Engine start/stop is provided at each operating location.

EMERGENCY CONTROLS

A manually operated hand pump is included to return the platform to the transport position.

OUTRIGGERS

Three outrigger configurations are provided on this machine;

- **Full width** – allows maximum working load at full outreach through 360-deg. rotation. Jack spread 3.8m.
- **One sided** – allows maximum working load at full outreach through 180 deg rotation on fully jacked side. Jack spread 2.9m.
- **Narrow Jacking** - allows maximum working load at limited outreach through 360 degrees. Jack spread 2.35m.

INTERLOCKS

- Booms cannot be raised until jacks are correctly deployed.
- Jacks cannot be operated unless booms are in transport position.
- PTO cannot be engaged unless handbrake is on.
- If engine is running starter cannot be engaged from the platform.
- The platform is automatically prevented from lowering or rotating into the cab or jacks.
- The platform will stop working should the cage be overloaded.

In addition to the above, warning lights are provided indicating:

- Booms not stowed.
- Jacks not stowed.
- One sided, narrow or full width jacking selected.

HYDRAULICS

The hydraulic system is of failsafe design throughout, with direct mounted load control valves fitted to all cylinders as a precaution against hose failure.

The hydraulic power take off on the vehicle draws from a large capacity hydraulic oil tank. Filters are provided for suction, pressure and return lines. Pressure limiting valves are provided where appropriate.

SAFETY

The machine is designed in accordance with the requirements of the European machinery directive and will be provided with a “CE” mark.

Testing of the unit will include a 125% overload test with the machine set up in its most unfavorable condition and a witness certificate provided.

STEELWORK PROTECTION

All steelwork will be shot-blasted prior to painting primer/undercoat and gloss finish. Typical paint thickness 90 to 110 microns.

PINS, BUSHES AND FITTINGS

All pins are stainless steel running in bushes that can be greased. All fittings, nuts and bolts are plated against corrosion.

A18-13TJ GENERAL ARRANGEMENT

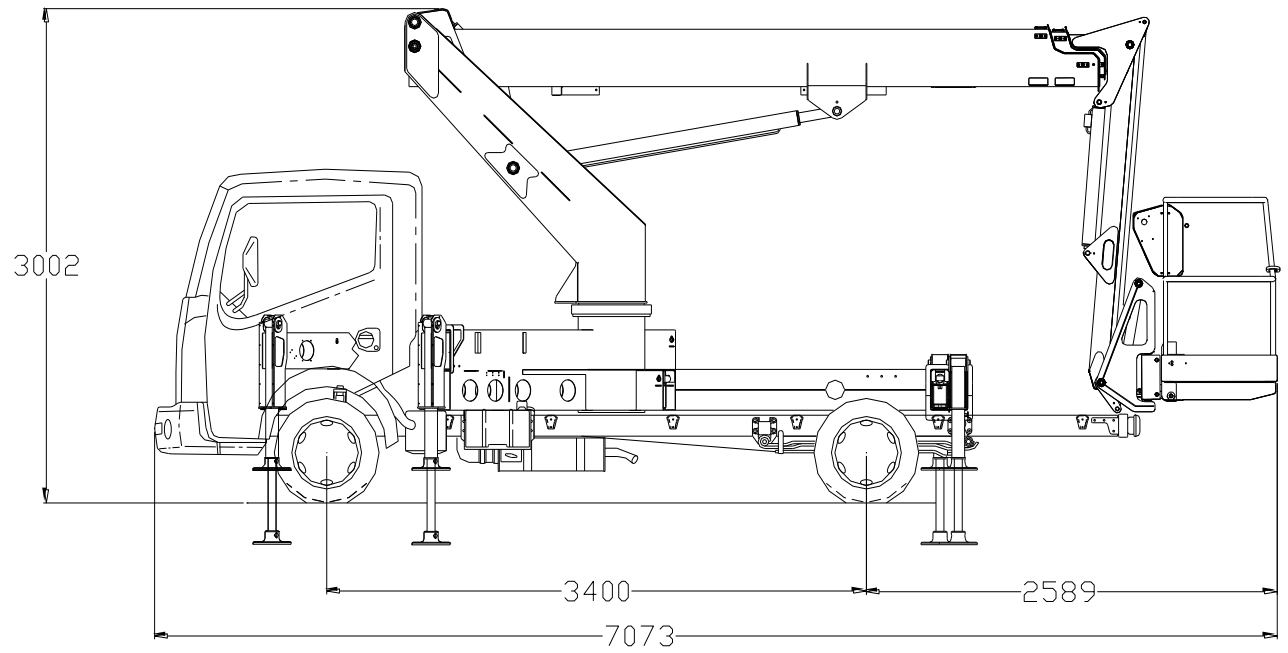
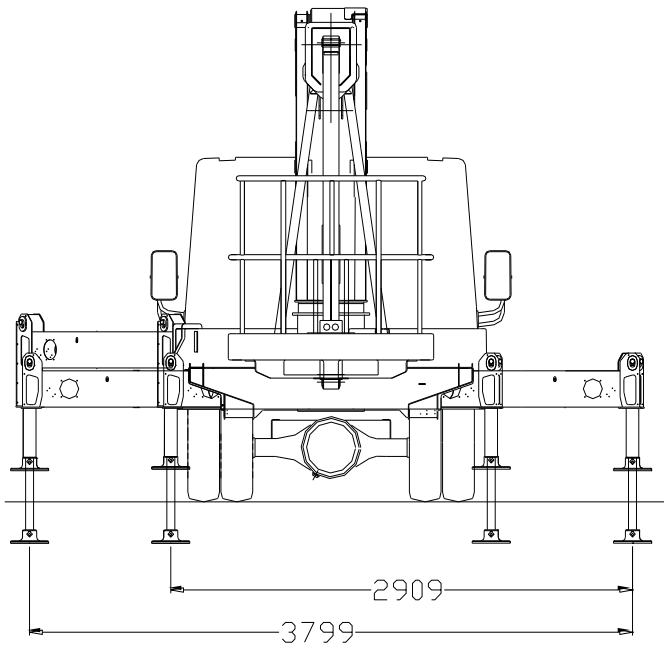

A18-13TJ WORKING ENVELOPE

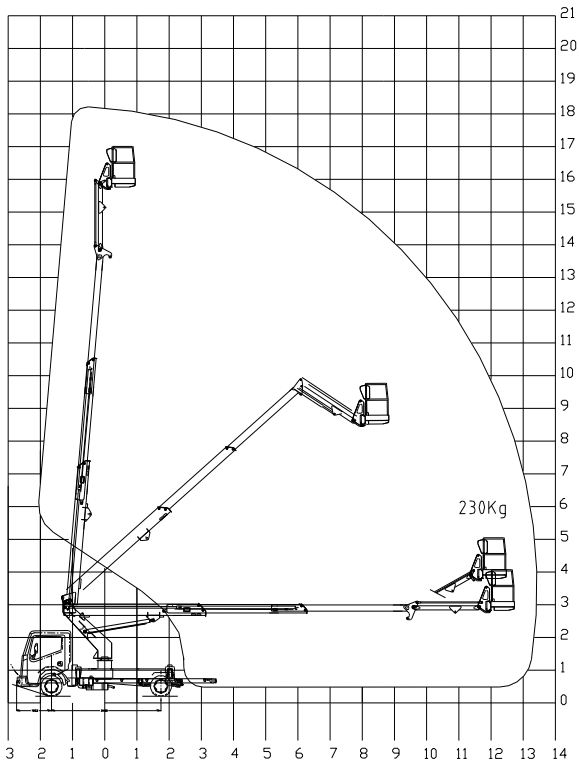

(Wide Jacking 360° rotation)

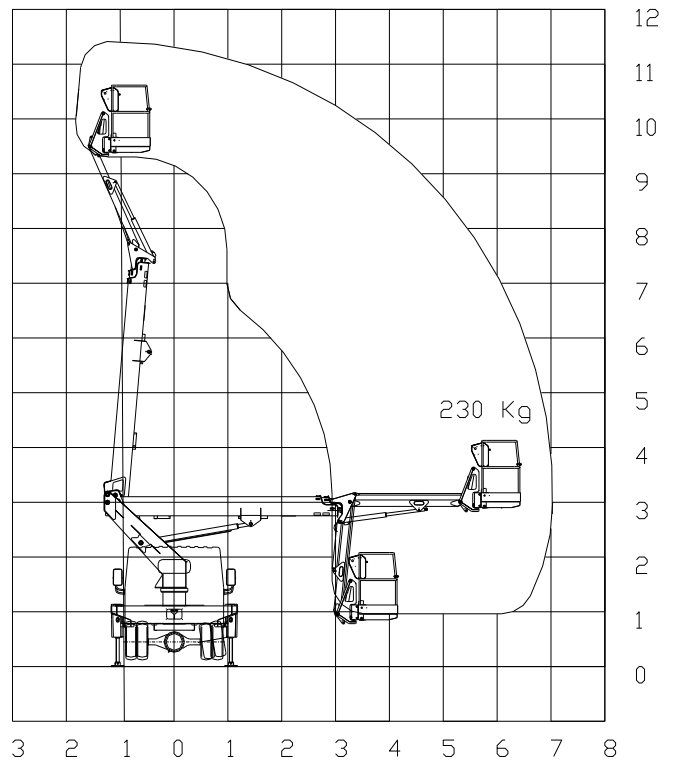

(Narrow Jacking)

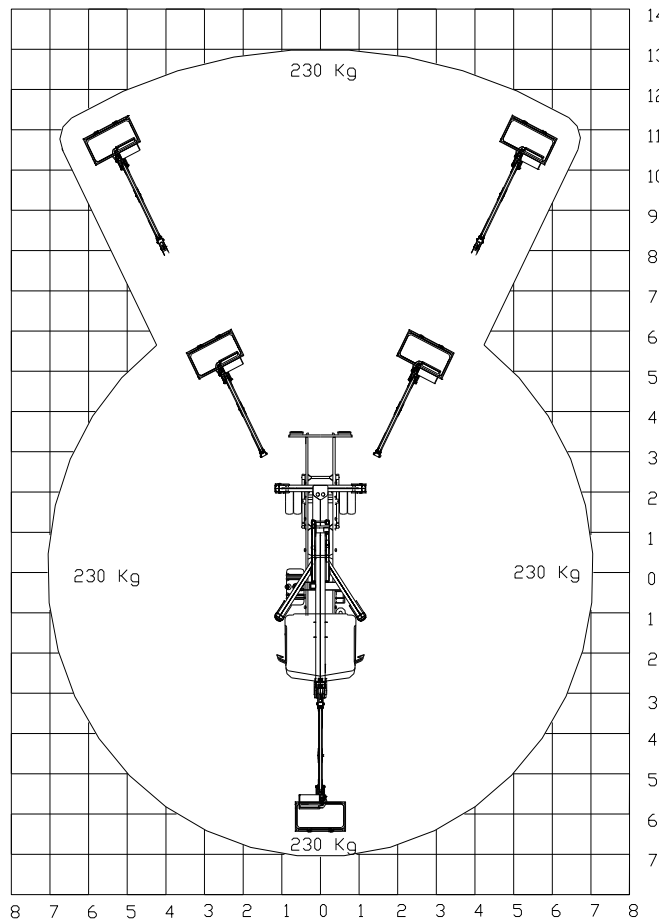

(Narrow Jacking)

SECTION 2 - SAFETY

THIS SECTION OF THE MANUAL CONTAINS GENERAL SAFETY INFORMATION FOR ALL PERSONS WHO HAVE ACCESS TO THE MACHINE (MACHINE OPERATIVES, MAINTENANCE PERSONNEL, ETC).

TO ALL PERSONNEL:

Before the machine is unloaded from the transportation and unpacked, and before it is released into service, ASCENDANT ACCESS LTD recommend that this safety section should be read and fully understood by all individuals involved.

2.1 GENERAL SAFETY COMMENTS

NOISE

During normal operation the maximum sound level will not exceed 85 DbA.

THE OPERATOR

- Must be medically fit and have good eyesight and hearing. Any medical condition that may affect the safe use of this access platform must be reported e.g. epilepsy heart disease etc.
- Must have a good head for heights.
- Must have been trained in the safe use of access platforms, hold a current certificate and be fully conversant with the content of this manual.
- Must be very aware of the safety requirements concerning the persons working with them and the persons in the general vicinity of the access platform.
- Must not use this piece of equipment for any purpose other than that for which it was intended.
- Must carry out the necessary pre-start checks as described in the operating section of this manual and must not operate the platform should it not be in first class condition.
- Must never get on or off the work platform when elevated

2.2 WARNINGS

DO NOT operate this platform:

- On surfaces that are sloping, not hard standing or slippery without adequately supporting the platform. The 18-13 has been designed to work on surfaces with a minimum bearing strength of 50N/cm²
- With items likely to increase the wind loading on the platform above acceptable levels e.g. notice boards etc.
- With any equipment in the cage likely to increase the working height or outreach e.g. ladders.
- For any special purpose that may produce special loads or forces. (as use of a crane). Any such application must be discussed with the manufacturer and their approval given.
- Near or close to live electrical conductors. The minimum safe distance for the 18-13 is 26.7m measured from the centre of rotation of the platform to the power lines. It is the operator's responsibility to ensure this safe distance is maintained.
- Should it be necessary to work closer to the power lines then the operator must ensure that the power has been switched off before attempting to work, a written permit to work must be obtained from owners of the power cables or the responsible Persons.
- Unless there is a current certificate of safe use of the platform issued by a competent person.
- Into the path of oncoming traffic when working on a public highway.

2.3 MAXIMUM WIND SPEED

BEAUFORT WIND SPEED SCALE

The Beaufort wind speed scale is accepted internationally and is used in communicating weather conditions. It consists of numbers 1 to 17 each representing a certain velocity of wind at 10m above the ground in open conditions.

DESCRIPTION OF WIND SPECIFICATION FOR USE ON LAND SPEED (m/s)

0 CALM	Calm, smoke rises vertically	0-0.5
1 LIGHT AIR	Direction of wind indicated by smoke but not by weather vanes	0.6-1.5
2 LIGHT BREEZE	Wind felt on face, leaves rustle, ordinary vanes moved by wind.	1.6-3.0
3 GENTLE BREEZE	Leaves and small twigs in constant motion, wind extends light flag.	3.5-5.0
4 MODERATE BREEZE	Raises dust and loose paper, small branches are moved.	6.0-8.0
5 FRESH BREEZE	Small trees in leaf begin to sway, wavelets form on inland waterways.	9.0-10.0
6 STRONG BREEZE	Large branches in motion, umbrellas used with difficulty.	11.0-13.0
7 NEAR GALE	Whole trees in motion, inconvenience felt when walking into wind.	14.0-17.0
8 GALE	Breaks twigs off trees, generally impedes progress.	18.0-21.0
9 STRONG GALE	Slight structural damage occurs. (chimney pots and slates removed).	22.0-24.0

Approximate corrections for wind speeds at other heights: 2m subtract 30%, 3m subtract 20%, 6m subtract 10% 15m add 10% and 30m add 30%

The maximum wind speed for safe operation of an 18-13 is 12.5m/s (Beaufort scale 6)

SECTION 3 - OPERATOR GUIDE

3.1 SAFETY

Please read Section 2(SAFETY) of this manual.

3.2 PRE-START CHECKS

The following pre-start checks must be carried out before operating the platform.

- Hydraulic fluid
The oil level in the tank must be full when the platform is in the transport position.
- Cut out switches
All cut-out and safety switches must be working correctly.
- Emergency stops
Check that the emergency stops are operating correctly and that they are all in the run condition.
- Damaged/loose fittings
Inspect the machine to ensure there are no signs of damage or loose hoses and fittings.
- Vehicle
Check that there is enough fuel in the vehicle for a full shifts work.

3.3 SETTING UP

Do not attempt to set up the machine on steep slopes, ramps or soft ground.

Maximum chassis inclination 0deg.

Maximum slope machine may be levelled on, with provided spreader boards, is 3deg fore and aft (cab may be uphill or downhill).

- Park the vehicle in an appropriate location, remove from gear and apply the handbrake.
- Ensure that the working area of the platform is coned off.
- Depress the clutch and switch on the PTO/Platform Power switch (located on the dashboard). Release the clutch.
- Leave the vehicle cab and go to the outrigger control station positioned at the rear of the vehicle.



OUTRIGGER DISPLAY

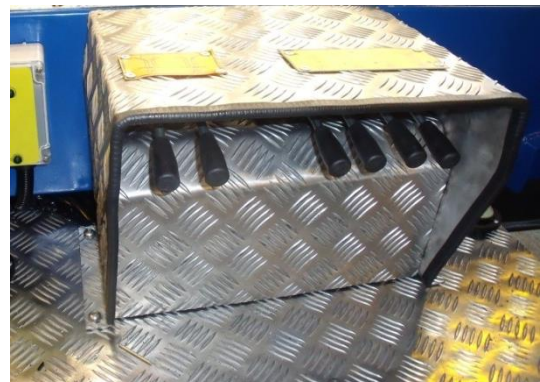

OUTRIGGER CONTROLS

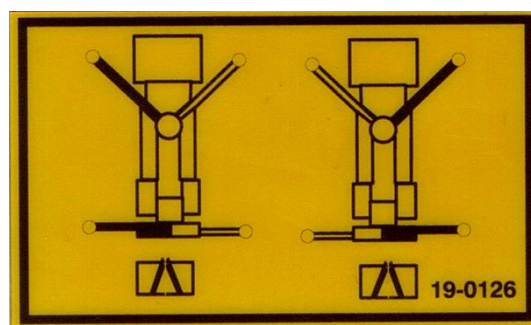

OUTRIGGER BEAM CONTROL LEGEND

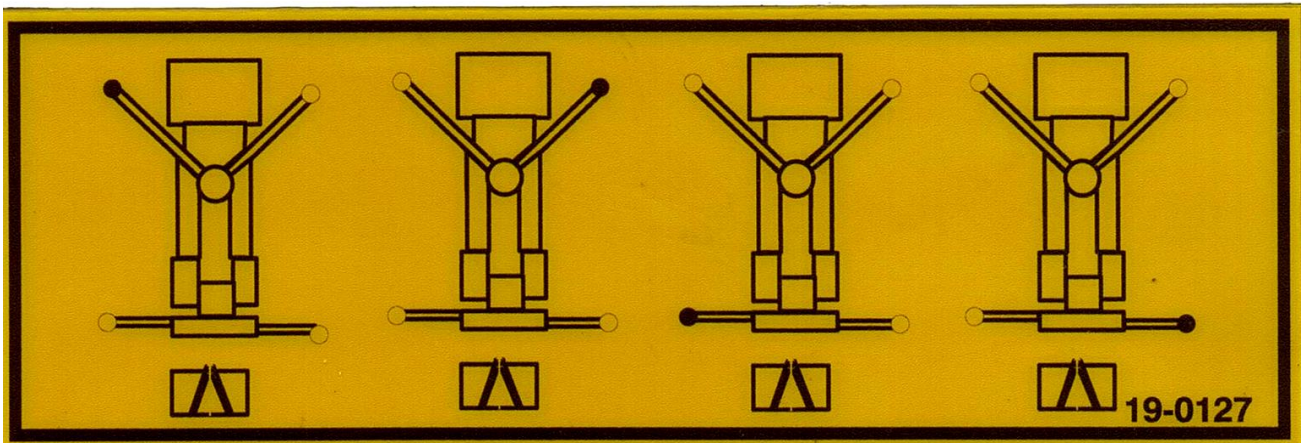

OUTRIGGER JACKS CONTROL LEGEND

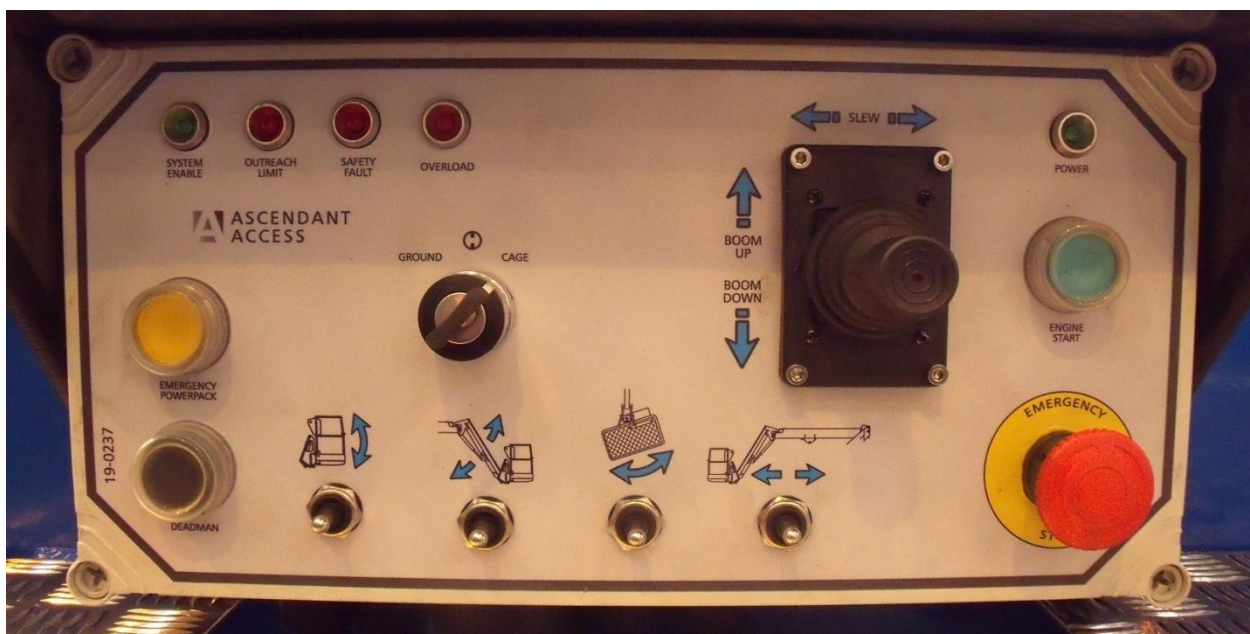

GROUND CONTROL STATION

- Select, full width, near-side or off-side working by actuating the appropriate outrigger beam configuration. (Note; The outrigger display shows a green light to indicate which mode the outriggers are in.)
- Operate the outrigger jack controls until all four feet are just touching the ground, then, simultaneously operate the front (cab end) jacks and then the rear until all jacks are in firm contact with the supporting surface, the chassis is level (according to the level gauge) and the wheels are approximately 5-10cm off the ground. (Four green “Outriggers under load” lights should show on the outrigger control box).
- Check that the feet are in firm contact with the ground

- Remember the maximum load that will be imposed by the platform foot and be sure the surface you have set it up on can support it.

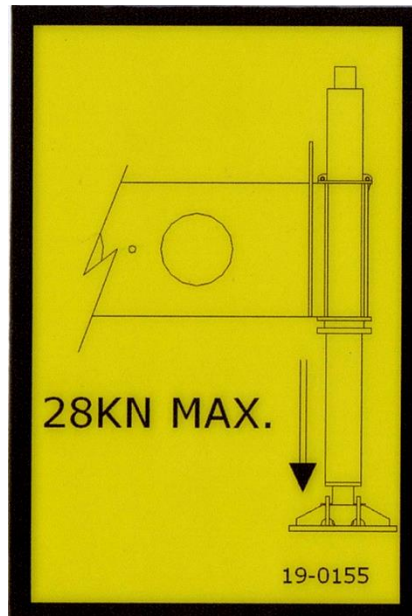

- The platform may now be operated from either the turret or the cage by operating the selector switch positioned on the ground control box.

3.4 OPERATING THE PLATFORM

ASCENDANT ACCESS LTD recommends the use of a safety harness. Harness anchor points are located in the cage.

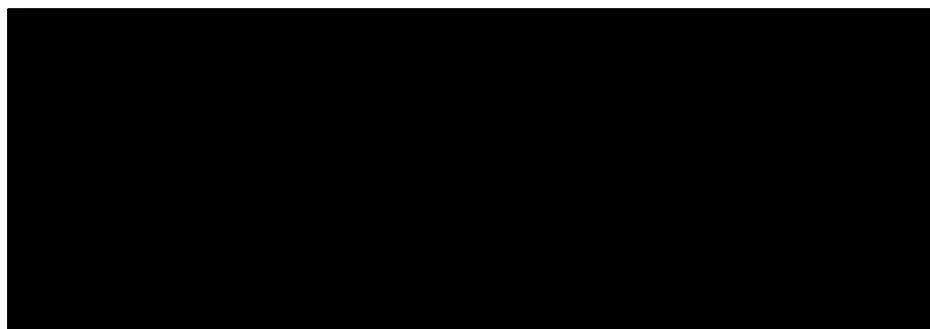

- The extending structure operating controls are the same at both operating stations.

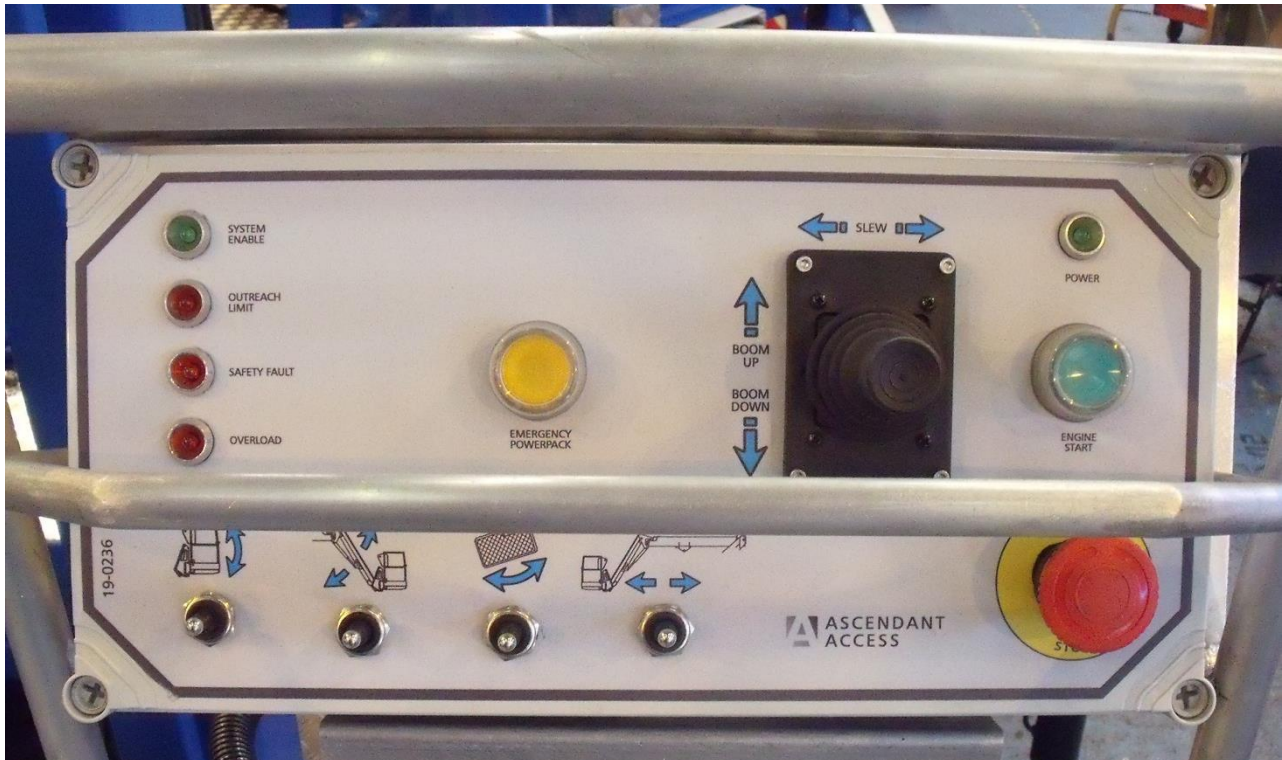

CAGE CONTROL STATION

The booms can now be operated freely by using the appropriate control lever.

WARNING Before raising. Ensure that there are no overhead obstructions.

Should the cage overload light show on the control box, the platform must not be operated until the excess payload is removed.

- Vehicle engine remote stop and start is provided at all operating stations.
- When working in one-sided jacking mode the extending structure will be prevented from moving into an unsafe condition. The platform will be free to move into a safe area by operating the slewing control.
- Should the cage become out of level whilst operating it may be reset by operating the cage trim lever.

3.5 EMERGENCY CONTROLS

- Red emergency stop buttons are located on the platform in the cage and at the base to stop the platform in an emergency.
- Emergency lowering of the booms is activated by depressing both the emergency power pack button and the deadman button simultaneously. This then allows normal operation of all functions through the emergency power pack.
- An emergency hand pump is provided (mounted on the near side of the chassis below the decking.) should all power fail. It is possible to operate the boom, telescope and fly boom to enable emergency lowering of the boom. To do this, manual operation of the appropriate hydraulic valve and main dump valve is needed. The ends of the hydraulic solenoid valves contain a rubber switch. Depress the appropriate solenoid valve and the main dump valve and then operate the emergency pump simultaneously to achieve movement.

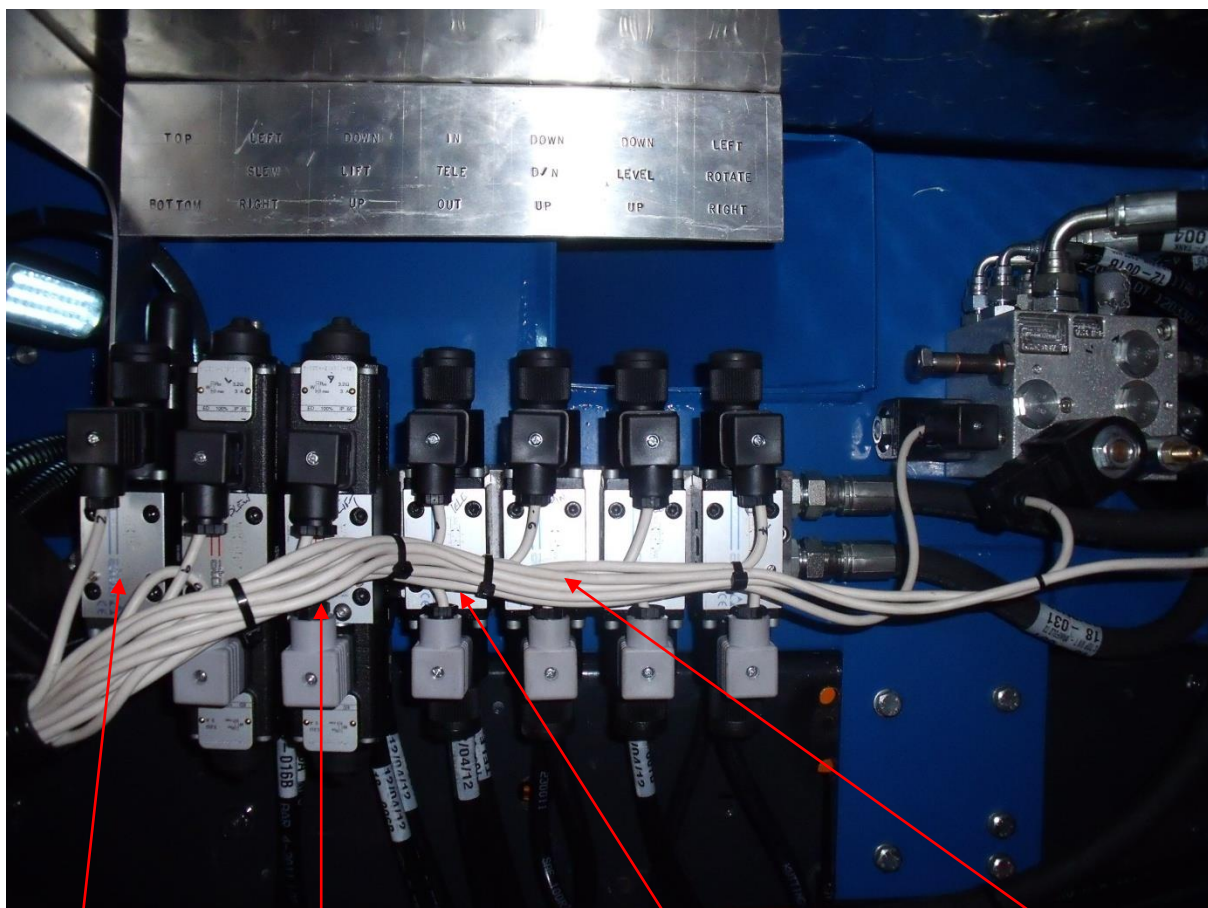

Main dump

Boom

Tele

Fly Boom

3.6 STOWING

- Telescope the boom fully in and line it up with the docking pocket. Lower both main and fly booms fully ensure the cage rotate is in its central position. Leave the cage.
- Fully raise the outrigger jacks. (note this will not be possible if the booms are not stowed).
- Fully retract the outrigger beams. (Note this will not be possible unless all outrigger jacks are fully up). The green “outrigger stowed” should show on the outrigger control box.
- Check that the “booms not stowed” and “outriggers not stowed” lights are out on the vehicle dash.
- Disengage the PTO
- Switch off the platform.
- The vehicle is ready to drive away.

SECTION 4 - MAINTENANCE

4.1 GENERAL

Before the PLATFORM is accessed for maintenance purposes, the operator should be informed of the intended action and suitable warning signs erected.

General tidiness should be considered a priority. Fluid spillage and debris should be cleaned up immediately to minimise the risk of slip, trip and / or fall. If the Platform is kept clean, it will make it easier to detect and rectify any faults that may occur.

For the long-term, efficient operation of this Platform to be a practical possibility, it is suggested that a planned maintenance scheme is adopted.

4. 2 MAINTENANCE AND LUBRICATION SCHEDULE

The following page shows the recommended service schedule for the Ascendant 18-13TJ work platform.

Explanation notes, where appropriate (marked thus*) follow the schedule. These notes must be read and understood.

Ascendant Access recommends that this inspection/ service work be carried out by competent personnel.

4.3 GENERAL MAINTENANCE

Daily Checks

- ∞ Hydraulic fluid. Top up the fluid level with the machine in the transport condition and on level ground. Use SHF 22 (ISO) or equivalent.
- ∞ Safety checks on platform control circuit (see below)
- ∞ Outreach limiting device. (if fitted)
- ∞

Weekly checks

- ∞ Apply grease to slew bearing and all grease nipples.
- ∞ Check boom pins/tie rods etc for damage.
- ∞ Check limit switch integrity.
- ∞ Check hoses and fittings for leaks/damage.
- ∞ Check cage overload system

6-monthly

A full technical inspection is to be carried out in accordance with the requirements of LOLOR by a competent person and a certificate of safe use obtained.

Service Parts:

High Pressure oil filter - MP FILTRI P/N - HP0502A10ANP01

Return Line oil filter - MP FILTRI P/N - MF0202P10NBP01

4.4 A18-13 SERVICE SCHEDULE

Description	Servicing Interval			
	Daily	weekly	monthly	Six monthly
Sub-frame to vehicle fastenings*				X
Outriggers*				X
Slew drive*				X
Pins. Bushes and fastenings*				X
Leveling system*				X
Cage and attachments*	X	X	X	X
Instructions, warning labels	X	X	X	X
Oil level	X	X	X	X
Control boxes*			X	X
Outreach limiting system*	X	X	X	X
Grease all points			X	X
Warning lights	X	X	X	X
Engine stop start	X	X	X	X
Emergency stops	X	X	X	X
Emergency pack	X	X	X	X
Booms/ wear pads etc*				X
Limit switches			X	X
All interlocking functions*	X	X	X	X
Hydraulic oil level	X	X	X	X
Change all filters	initial after three months then every year			
Change hydraulic oil	every year			
Slew gearbox oil	initial after three months then every fifth year			
Hyd hoses and fittings			X	X
Electric cables			X	X

∞ **Sub-frame to vehicle mounting;**

Check: integrity of all connections for tightness, corrosion, cracking etc

∞ **Outriggers;**

Check: Cat-track fixings and functionality,
Hose / cable runs for leaks and chaffing.
Wear pad thickness and fixing.
When deployed check for cracking etc at joints.
Pins
Proximity switches and limit switches for functionality

∞ **Slew drive;**

Check: General condition of driving and driven gears
Gearbox oil level
Slew holding down bolts have not stretched (if they have then all bolts must be replaced immediately by units provided by Ascendant Access).
Re-torque holding down bolts. **Torque setting 100Nm.**
Check wear on slew bearing by gently lowering the cage onto the ground with the boom telescoped out a little. Keep lowering gently whilst watching at the bearing for any “rocking”. Total movement at the front of the bearing is allowed to be 1mm or less. Any more than this then the bearing should be refurbished or replaced.

∞ **Pins, bushes and fastenings.**

Check; All pins for freedom of movement, corrosion, lubrication, fastening etc.
All bushes for signs of wear or damage.

∞ **Leveling system.**

Check: The cage remains horizontal automatically whilst raising and lowering the main boom.
Check trimming controls move the cage smoothly and slowly.
With a load in the cage switch off the platform and operate the trimming valves. The cage should remain stationary.
The cylinders, hoses for signs of corrosion, wear etc.

∞ **Cage and attachments**

Check; General condition of cage rails, access bar, floor and attachment to boom, especially the condition of all welded joints.
Cage overload device. With 260kg uniformly distributed in the cage the alarm should sound. Removing 30 Kg should make the alarm go off. Adjustment of the cage switch may be carried out (see cage switch ref 3.2.4).

∞ **Booms, wear pads etc.**

Check; General condition of all welded seams.

Any signs of damage or distortion.

With the booms telescoped out fully, horizontally, check for signs of distortion particularly at the boom junctions.

Wear pads for excessive wear.

The adjustable wear pads should be adjusted so that the gap between them and the highest point on the boom surface is not less than 2mm (it will be necessary to telescope out the boom until the highest point is located).

Remove the rear cover and check the condition of all internal pins rope rollers etc. Check the condition of the cat-track and guides. Check that there is sufficient grease on the internal surfaces.

∞ **Wire rope inspection and adjustment.**

Generally the wire ropes require little maintenance during their lifetime but must be inspected every 250 hours or 3 months.

Ascendant Access recommends that the wire ropes be replaced after 10000 hours or 10years.

Inspection of the ropes and terminals can be carried out as follows.

Remove the boom rear cover

Telescope the boom out a little until the rope terminals become completely visible. Check for any signs of wear or distress in this connection.

Move to the front of the fixed boom and inspect the corresponding terminals on the retract assemblies through the apertures on the underside of the boom near the boom prop.

The opposite end of each rope is attached to the inner boom at the rear and should be visible with a torch and the booms telescoped out approximately 200mm

Telescope the boom out and with a torch at the rear of the boom assembly inspect the ropes for any signs of fretting or unwinding etc.

Tensioning of the ropes should not normally be required but great care must be taken to ensure that the ropes have equal tension applied to them. This can be affected by setting the spring stacks to exactly the same loaded length.

When tensioning the assemblies ensure that equal amounts of slack are taken up both the extend and retract assemblies. This will ensure the inner boom remains in the same relative position.

∞ **All interlocking functions.**

All limit switches installations must be checked for integrity. The following functional checks should then be carried out.

4.5 SAFETY

CHECKS ON PLATFORM CONTROL CIRCUIT

With the vehicle parked, engine running, platform switched on and the platform in transport position check.

- ∞ Booms not stowed light is not on.
- ∞ Outriggers not stowed light is not on.

Engage the PTO.

Leave the cab and move to the boom controls (turret and cage).

- ∞ It should not be possible to operate the booms using the appropriate controls.

Move to the outrigger controls.

- ∞ The outriggers stowed light should be on.
- ∞ Lower each jack a little in turn and it should not be possible to deploy the outrigger beams.
- ∞ Deploy the outrigger beams and check that it is still not possible to operate the booms from either control station.

Jack up the machine as described in the operating instructions.

- ∞ The appropriate jacking mode light is lit at each control station.
- ∞ Each outrigger under load light is on. (outrigger control box).
- ∞ Check that it is possible to operate the booms from both locations.

Depress the emergency power pack button.

- ∞ The vehicle engine should stop.
- ∞ The controls should work with the button depressed, albeit slowly.
- ∞

Restart the engine.

Depress the emergency stop.

- ∞ It should not be possible to operate anything.
- ∞ The vehicle engine should stop

Release the stop.

With the booms lifted out of the prop a little (5-10 cm)

- ∞ Check that it is not possible to operate either the outrigger jacks or the outrigger beams.
- ∞ Check that the booms not stowed light is on in the vehicle cab.

At low level slew the booms in the direction of the cab. The booms should stop rotating automatically when it approaches the cab. It should be possible to slew in the opposite direction.

Raise the boom approximately 30 degrees and place it over the cab. Lower the boom and again it should stop lowering as it approaches the cab. It should be possible to raise the boom.

Jack up the machine in one-sided mode and check.

- ∞ The platform should stop automatically when slewed over the rear towards the narrow jacked side after approximately 15 degrees of slewing from the centre line of the vehicle. It should be possible to slew in the opposite direction.
- ∞ The platform should also stop just before it is directly over the cab end outrigger. Slewing in the opposite direction should be possible.

Return the platform to the transport position and repeat the procedure over the other side.

Should it not be possible to slew the platform away from the working envelope limit then the primary safety circuit has failed and the back up system is operating **DO NOT USE THE PLATFORM UNTIL THE FAULT HAS BEEN RECTIFIED.**

4.6 LUBRICATION DIAGRAM

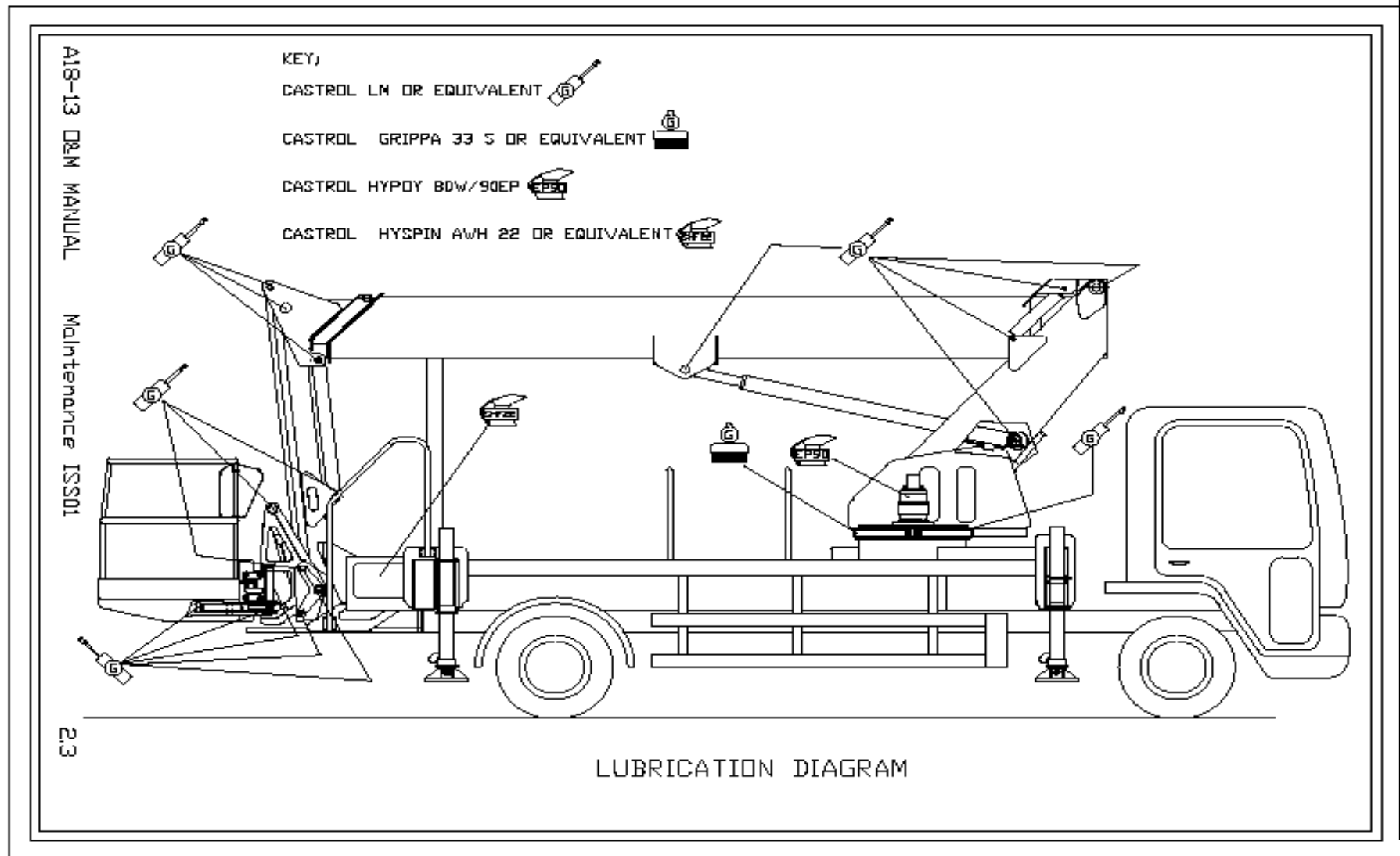

4.7 SIX MONTHLY INSPECTION SCHEDULE

Six Monthly Thorough Examination Inspection Schedule - Vehicle Mounted

Owner _____ Location _____ Date _____

Machine type _____ Serial No _____

Hour clock _____

ITEM	CHECK	S	U/S
Chassis			
Main frame/mountings	security / cracks / corrosion		
Outriggers	security / cracks / distortion		
	no hydraulic leaks		
	wear pad clearances		
	creep within specified limits		
PTO / engine / pump	mounting security and condition		
	no oil or fuel leaks		
	electrical cables and battery		
Cab/outrigger controls	mounting secure		
	all controls function correctly		
	all decals present & legible		
	warning lights operational		
	no hydraulic leaks		
Access to truck deck	electrical cable installation		
	ladders and grab handles secure & undamaged		
	decking plates security & condition		
Platform			
Boom Sections	no cracks / corrosion / damage		
Cage boom	“ “ “		
Turntable	“ “ “		
Cage	“ “ “		
	attachment points		
	Access bar self closes		
	safety harness anchor points - security		
Pins / bushes/bearing	all locking devices secure		
	excessive wear		
	evidence of correct lubrication		
Boom tele ropes	condition / adjustment / lubrication		
Rope sheaves	“ “ “		
Wear pads	“ “ “		
Boom & tele cylinder's	Security / condition / no leaks / creep within limits		
Slew ring	all mounting bolts present and secure		
	bearing wear within limits		
	evidence of correct lubrication		
Slew motor	mounting / backlash / gear teeth condition		

**Six Monthly Thorough Examination Inspection Schedule cont'd
Vehicle mount**

ITEM	CHECK	S	U/S
Control Centres			
Cage and ground	enclosure condition & mountings secure		
	safety & operational decals presence & legible		
	warning lights operational		
	all controls function correctly		
Emergency Stop's	operate correctly & buttons latch in		
Cage leveling	automatic leveling system works correctly		
	manual system works correctly		
Emergency pump	operates all functions		
Safety Interlocks	check operation of all systems		
	outriggers stowed – legs up & beams in / out		
	individual outrigger ground pressure		
	boom raised interlock with outriggers operates		
	cage overload system works		
	cab protection zone		
Outreach limiter	condition of mechanical components & all switches		
	outreach correct		
Jacking options	Full / half / narrow– rotation stop function		
Hydraulic hoses	visual external inspection - no leaks or damage		
Hydraulic oil level	correct and condition of filler cap		
Electrical cables	visual external inspection		
Covers	condition and security		
Flashing lights	Presence and operate –		

NOTES:

All visual examinations carried out by opening the appropriate inspection covers.

Slew ring bolt security - visual check only.

(torque settings to be checked in accordance with the service manual)

S = serviceable

U/S = requires attention.

N/A = not applicable

Six Monthly Thorough Examination Inspection Schedule cont'd Vehicle mount

Description of defects / comments

ITEMS	DESCRIPTION / COMMENTS	RECTIFIED

Inspection carried out by _____ Print

_____ Sign

Inspection authenticated _____

SECTION 5 - TROUBLE SHOOTING

It is recommended that faultfinding be only carried out by technically competent personnel. Whilst every effort has been made to ensure that these procedures are comprehensive they will not cover every eventuality

- **Vehicle engine will not start**
 - Check all emergency stops are in the platform run condition.
 - Refer to vehicle manufacturer trouble shooting guide.
- **Outrigger beams will not operate**
 - Check platform is switched on (located in vehicle cab).
 - Check PTO is engaged.
 - Check that booms are correctly stowed and that the limit switch has not malfunctioned (located behind cover on boom prop).
 - Check micro-switch on beam deploy valve.
 - Check hydraulic oil level.
- **Outrigger jacks will not operate**
 - Check outrigger beams are correctly deployed.
 - Check boom docking.
 - Check oil level in hydraulic tank.
- **Booms will not operate**
 - Check correct operating station has been selected. (switch located at turret control box).
 - “Jacking” mode light on turret and cage control boxes should be lit.
 - Check that outriggers are correctly deployed (i.e. in firm contact with the ground and all indicator lights are correctly lit, (see operating guide)).
 - Check light leg indicator is not lit.
 - Check cab protection indicator is not lit.
 - Check outrigger limit switches are operating correctly.

SECTION 6 - INSPECTION RECORDS

INSPECTION RECORDS

Description of defects / comments

DATE	DESCRIPTION / COMMENTS	RECTIFIED

INSPECTION RECORDS

Description of defects / comments

DATE	DESCRIPTION / COMMENTS	RECTIFIED