

## WNS Flat 'S' Cleat Rollformer (FSC20)

**Manufactured by W. NEAL SERVICES LTD.**

W. NEAL SERVICES LTD  
 29 Purdeys Way  
 Purdeys Industrial Estate  
 Rochford  
 Essex  
 SS4 1ND  
 ENGLAND



WNS Flat 'S' Cleat Rollformer  
 20wg (1.0mm) Capacity  
 (FSC20)

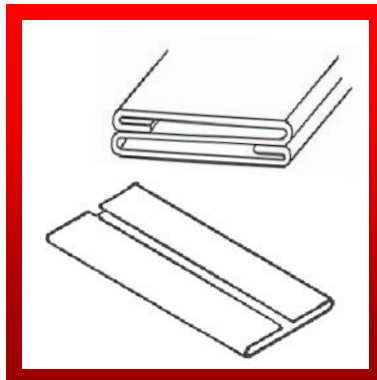

**WNS 20swg (1.0mm) 'S' CLEAT ROLLFORMERS** are 9 station machines. They are principally used in the HVAC industry for joining two ducts together in conjunction with drive cleat and plain seam rolls. Flat 'S' cleat rolls are fitted inboard with external double extended shafts, onto which many auxiliary rolls can be fitted. WNS Rollformers are manufactured with all steel side plates. The shafts, forming rolls, gears and guide fences are all hardened, and needle bearings are fitted throughout.

CE

SPECIFICATIONS							
Model:	Speed:	Motor Power:	Supply Voltage:	Length:	Width:	Height:	Weight:
FSC20	8.0m/min	2HP, 1.5kW	415v, 3 Phase	1650mm	615mm	1000mm	300Kg

Revised: Jan 2018

All capacities are based on the use of Rollforming quality Mild Steel. All specifications, dimensions and weights are approximate and are to be used as a guide. Colours may vary. W. Neal Services Ltd reserves the right to alter any specifications. E&OE.

## WNS Flat 'S' Cleat Rollformer (FSC20)

Manufactured by W. NEAL SERVICES LTD.



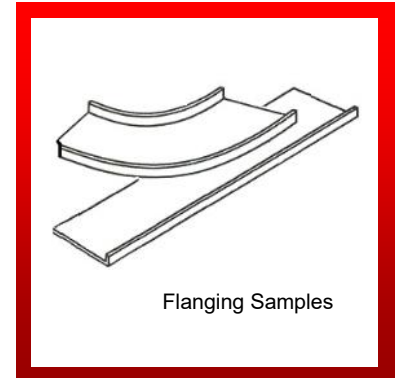
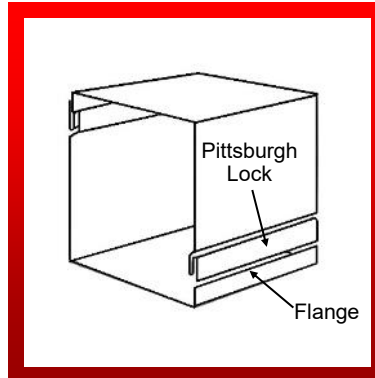
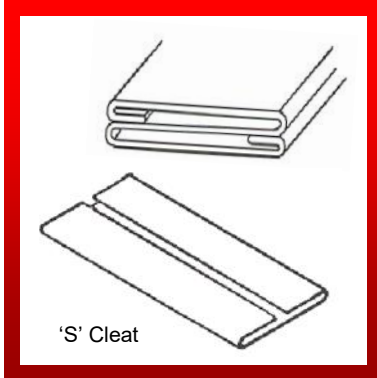

W. NEAL SERVICES LTD  
 29 Purdeys Way  
 Purdeys Industrial Estate  
 Rochford  
 Essex  
 SS4 1ND  
 ENGLAND

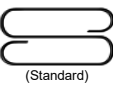

\*Optional Rolls which can be fitted to auxiliary shafts.

CE

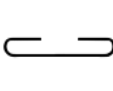
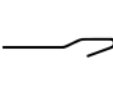
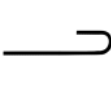
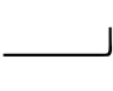
### SPECIFICATIONS

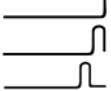
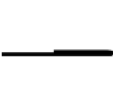
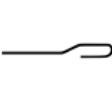
Auxiliary Rolls:	'S' Cleat Rolls Fitted Inboard:	Small Pittsburgh Lock *:	Drive Cleat *:	Double Seam*:	Plain Seam*:	Right Angle Flange*:	Standing Seam*:	3 in 1*:	Safe Edge*:	Closed Double Seam*:
Sections:	 (Standard)									
Maximum Thickness:	0.8mm	0.8mm	1.0mm	1.2mm	1.0mm	1.6mm	0.8mm	0.8mm	0.8mm	1.2mm
Material Used:	92mm	25mm	54mm	32mm	11mm	11mm	54mm	-	-	32mm
Seam Width:	27mm	10mm	29mm	13mm	10mm	-	-	-	8.0mm - 10mm	13mm
Flange Height:	-	-	-	-	-	Max. 11mm	-	-	-	-
Seam Height:	-	-	-	-	-	-	19mm	15mm	-	-

### Other Products in our Range....

