

3 QLC AG POWER CHUCKS

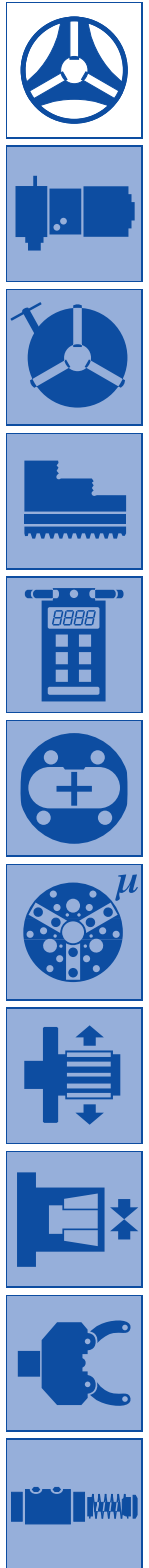
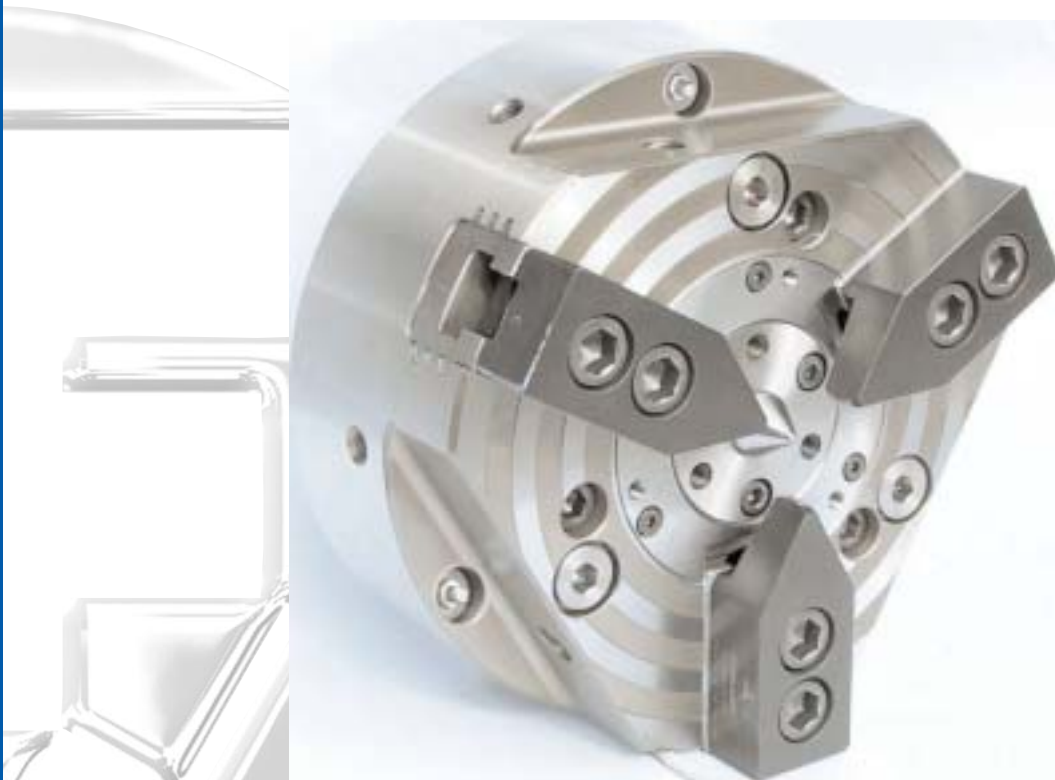

1. Specifications	Page	7. Assembly	Page
1.1 Notice	3	7.1 Steps to take before starting assembly	30
1.2 Intended applications and proper usage	3	7.1.1 Checking the spindle head for receipt of the chuck flange	30
1.3 Components of the power chuck	4	7.1.2 Checking the assembled chuck flange	30
1.4 Important specifications at a glance	5	7.2 Configuration of the connecting rod	31
1.5 Chuck constants	6	7.3 Counterbalancing the rotating parts	31
1.6 Designation of the chuck type	6	7.4 Assembly of the power chuck	32
1.7 Tightening torque of the fastening bolts	6	7.4.1 Procedure for assembling the power chuck	32
1.8 Lubrication spots – Drawing:	7	7.5 Assembly of the centering inserts	33
1.9 Notices on the power chucks	7	7.6 Attaching the top jaws	34
2. Safety Notices		7.7 Adjusting the limit switches to the power chuck's working path	34
2.1 General Information	8	7.8 Safety notices	35
2.2 Qualified personnel	8	7.9 Start-up preparations:	36
2.3 Danger notices	8	8. Start-Up, Operation	
2.3.1 Work-safety symbol	8	8.1 Notices	37
2.3.2 ATTENTION! - Notice	8	8.2 Start-up	37
2.4 Work-safety notices	9	8.2.1 Notices	37
3. General Information		8.2.2 Start-up, operation	38
3.1 Notices	10	8.3 Selecting oil	38
3.2 Copyrights	10	8.6 Impermissible operating methods	39
4. Transportation, Storage		8.7 Safety notices	39
4.1 Packaging, level of disassembly	11	8.8 Handling disturbances	40
4.2 Sensitivity, storage, items included in delivery	11	8.9 Restarting after a disturbance	40
5. Design and Operation		8.10 Steps to take during longer idle times	40
5.1 Power Chuck type 3 QLC – AG	12	8.11 Steps to take after longer idle times	41
5.1.1 General description	12	9. Repair, Maintenance	
5.2 Power chuck design	13 / 14	9.1 Maintenance	42
5.3 Power chuck versions	15	9.1.1 Notices	42
5.3.1 Power chuck type 3 QLC – AG, compensating chucking	15	9.1.2 Repair, maintenance	42
5.3.2 Power chuck type 3 QLC – AG, concentric chucking	15	9.2 Disassembling the power chuck	43 / 44
5.5 Centering Inserts	16	9.3 Safety notices	45
5.5.1 For compensating chucking with fixed tip type GS	16	9.4 Lubrication	46
5.5.2 For compensating chucking with spring-loaded tip type GF	16	9.5 Repair	47
5.5.3 For compensating chucking: type GZ	16	9.5.1 Notices	47
5.6 How the power chuck works	17	9.5.2 Replacing parts	47
5.6.1 Centrifugal force compensation	18	10. Replacement Parts and Customer Service	
5.6.2 Integrated lubricant reserve	18	10.1 Replacement parts	48
5.6.3 Sealing the power chuck:	18	10.2 Lists of replacement parts	48
5.7 Safety notices	18	10.2.1 Replacement parts list for power chuck type 3 QLC – AG	48
5.8 Gripping jaws:	19	10.2.2 Replacement parts list for centering insert type GS:	49
5.8.1 General information	19	10.2.3 Replacement parts list for centering insert type GF	50
5.9 Safety notices for top jaws	20	10.2.4 Replacement parts list for centering insert type GZ	50
5.13 Safety notices	21	10.3 Address for replacement parts and customer service	51
5.14 Safety requirements for power-operated clamping devices	22	11. Exhibit	
6. Gripping Force		11.1 Tools and accessories	52
6.1 General information	23	11.2 List of associated brochures	52
6.2 Gripping force F _{spo}	23	Manufacturer's Declaration	53
6.2.1 Operational gripping force F _{sp}	23 / 24		
6.3 Safety notices	25		
6.4 Calculation examples	26 / 27		
6.5 Calculation of the gripping force F _{spz} necessary for the machining process	28		
6.6 Permissible clamping length	29		

1.1 Notice:

Carefully read and observe these operating instructions before unpacking and bringing into operation the “power-operated triple-jaw compensating chuck” type 3 QLC - AG! The power-operated triple-jaw compensating chuck model QLC - AG may be used, maintained, and repaired only by persons above the age of eighteen years who have read and understand the operating instructions.

1.2 Intended applications and proper usage:

The power-operated triple-jaw compensating chuck type 3 QLC – AG (hereafter referred to as “power chuck”) is actuated by a rotary drawbar cylinder whose axial actuation force must be adapted to the power chuck.

The power chucks may be used only for the ***intended application and in the proper manner***. The ***intended application*** is to chuck and machine work pieces on:

lathes and other

rotating tool machines.

Do ***not*** exceed the power chuck’s maximum axial force, maximum gripping force, and maximum rotational speed.

Employ the appropriate engineering principles (such as VDI 3106) to determine the permissible rotational speed or the necessary gripping force for the respective cutting application.

Proper use also includes compliance with the start-up, assembly, operational, and maintenance conditions required by the manufacturer.

Any other use or more extensive use is improper. The manufacturer will not be responsible for any damages caused by improper use.



AG 01a

1.3 Components of the power chuck:

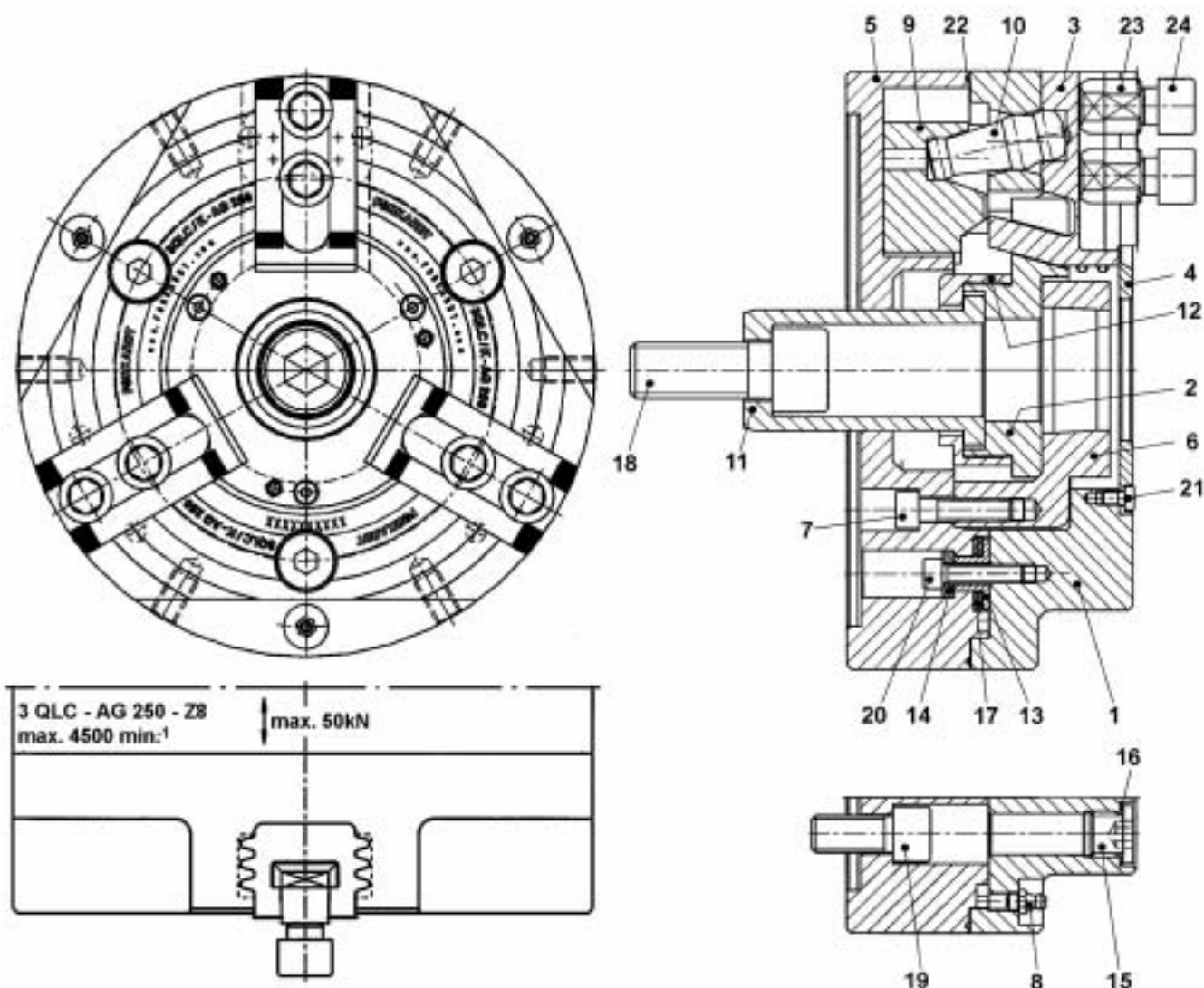

AG 02

Part No.	Name
1	Chuck body
2	Chuck piston
3	Base jaw
4	Protective bushing
5	Chuck cap
6	Holder
7	Machine screw M10x40 DIN 912 10.9
8	Cone lube nipple
9	Centrifugal weight
10	Lever
11	Tension sleeve
12	Threaded bushing

Part No.	Name
13	Spring sleeve
14	Washer
15	Locking screw
16	Sealing ring 21x26x1.5 DIN 7603 Cu
17	Cup spring 31.5x16.3x1.75 DIN 2093
18	Machine screw M24x60 DIN 912 10.9
19	Machine screw M16x35 DIN 912 10.9
20	Machine screw M8x35 DIN 912 10.9
21	Machine screw M6x10 DIN 7984 8.8
22	O-ring 240x2
23	Sliding block M16 FN 232
24	Machine screw M16x35 DIN 912 10.9

1.4 Important specifications at a glance:

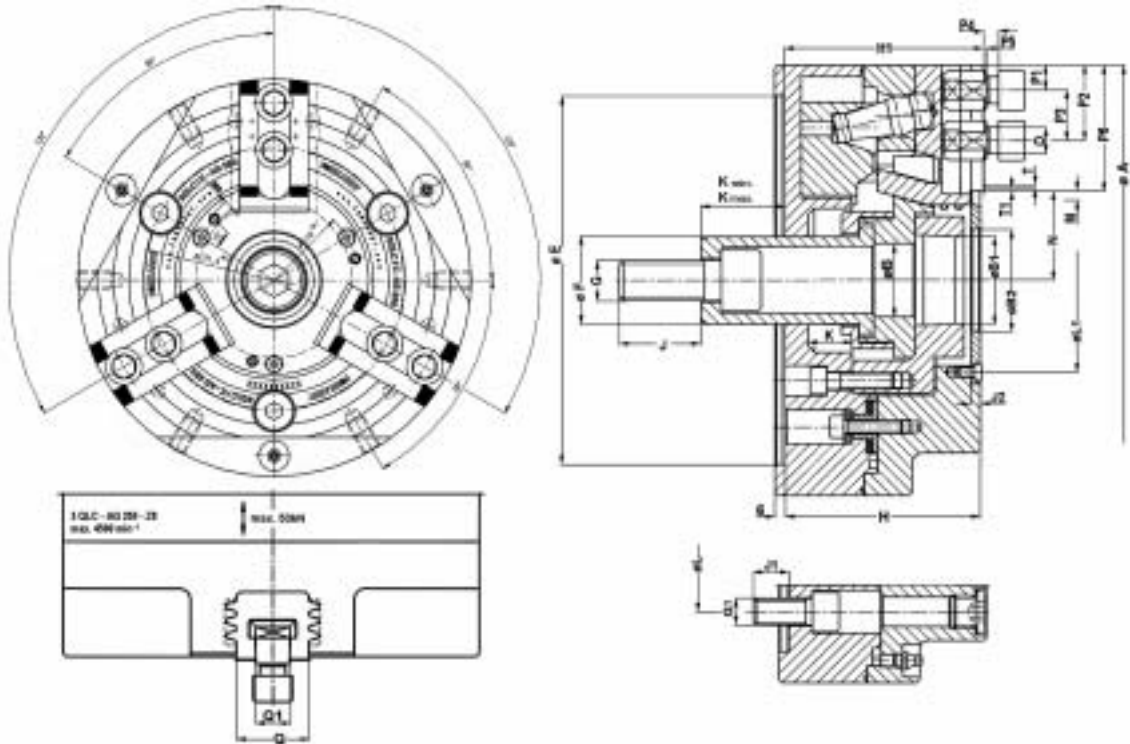

Chuck type	QLC - AG	→	175	200	250	315	400
ID No.	→				169747		
Chuck size	\varnothing A				257		
Piston bore	\varnothing B				44		
Spindle connection	C				Z8		
Jaw connection	D				S12		
Center bore holder	\varnothing B1				52		
Center bore protective bushing	\varnothing B2				61		
Chuck centering	\varnothing E H6				220		
Threaded tension bolt	G				M24		
Threaded fastening bolts	G1				M16		
Chuck body height	H				118		
Chuck height	H1				120		
Thread length of tensioning bolt	J				48		
Thread length	J1				21		
Piston stroke	K				20		
Tension sleeve position	K min K max				50 70		
Reference circle	L \pm 0.2				171.4		
Jaw stroke	M				5.4		
Jaw position	N min N max				48.1 53.5		
Jaw fastening bolts	O				M16		
Jaw width	Q				45		
Channel width	Q1				21		
T sliding block					FN 232		
Max. actuation force	Fax max				5000		
Max. rotational speed	n max				4500		
Gripping force Fspo	daN				12000		
Moment of inertia	J	kgm ²			1.0		
Flywheel effect	GD ²	kpm ²			4.0		
Weight	G	kg			33		

1.5 Chuck constants:

Chuck type →	QLC - AG 175	QLC - AG 200	QLC - AG 250	QLC - AG 315	QLC - AG 400
C 1			916		
C 2			398		
C 3			0.2		
C 4			0.0005		

The chuck constants account for the chuck-specific characteristics. These are needed to calculate the gripping force at idle ($n=0$) and at working speed and to calculate the gripping jaws' permissible centrifugal torque. See also section 6.4!

1.6 Designation of the chuck type:

3	QLC - AG	250	44	Z8	S 12	165 568
Number of jaws	Chuck version	Chuck size	Chuck centre bore	Spindle connection	Jaw connection	ID No.

1.7 Tightening torque of the fastening bolts:

DIN 912 screws		Quality 10.9				Complies with DIN 267		
Threads		M 4	M 6	M 8	M 10	M 12	M 16	M 20
Tightening torque	Nm	4.4	15	36	72	125	290	560
Max. screw load	N	5800	13200	24300	38700	56500	110000	171000

Quality 8.8 Complies with DIN 267		DIN 7984-compliant screws		DIN 912-compliant screws
Threads		M 5	M 6	M 4
Tightening torque	Nm	5	8.5	3.0
Max. screw load	N	4850	6700	3900

1.8 Lubrication spots – Drawing:

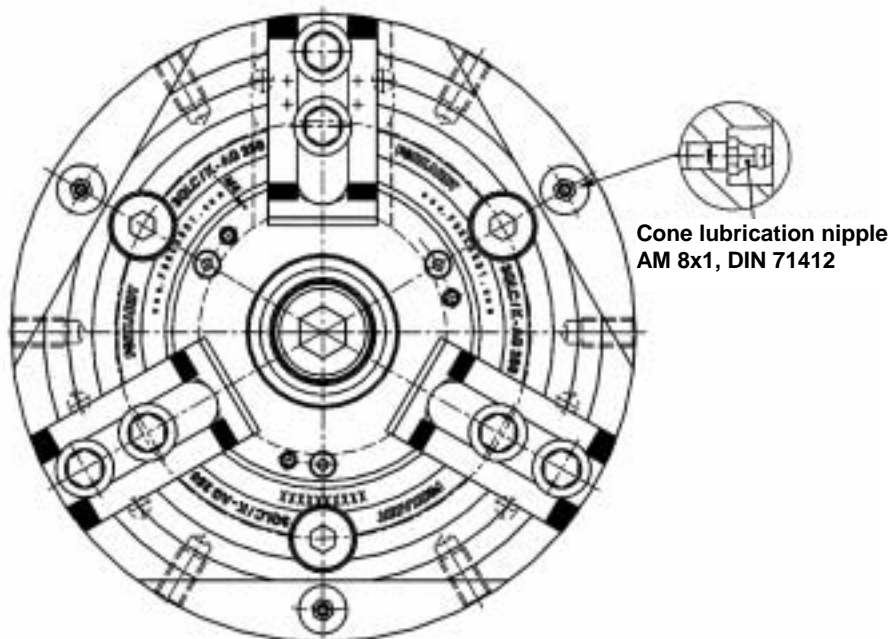

1.9 Notices on the power chucks:

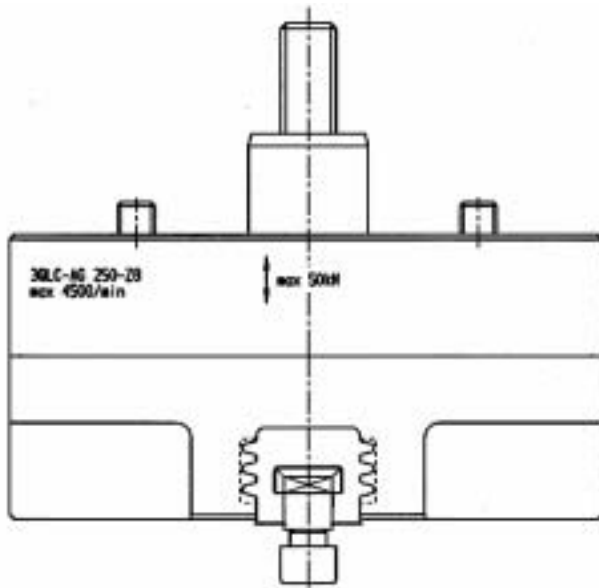

AG 05

On the outside diameter of the power chuck:

Type of the power chuck, nmax, and maximum permissible activation force.

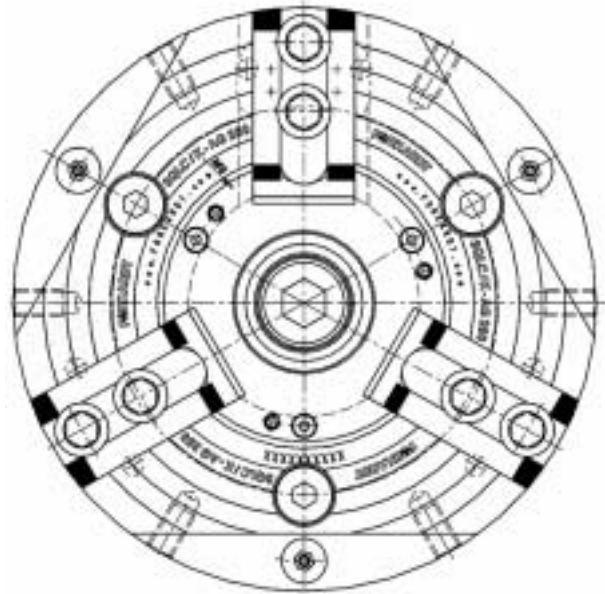

AG 06

On the face side of the power chuck:

Fabrication No., ID No., FORKARDT reference

2.0 Safety Notices:

2.1 General information:

These operating instructions contain the information needed to properly use the power chuck type 3 QLC – AG. These instructions are intended for use by qualified, specially trained personnel.

Awareness of the safety notices and warnings contained in these operating instructions and their flawless implementation are prerequisites for safe handling, operation, and repair of the products described. Only qualified personnel (as described under point 2.2) will have the technical knowledge needed to correctly interpret and implement these general safety notices and warnings in a manner that is appropriate under the actual conditions encountered during specific applications.

ATTENTION!

We accept no liability for any damages that occur due to a failure to observe these operating instructions!

2.2 Qualified personnel:

Unqualified interference in the power chuck or failure to observe the warnings contained in these operating instructions can lead to serious injury or material damages. For this reason, only properly qualified personnel may work on these power chucks. For the purpose of the safety notices in these operating instructions, qualified personnel are:

- operating personnel who have been instructed in the proper operation of power chucks and who understand the sections of the operating instructions that deal with proper handling of the power chucks.
- or persons charged with start-up and service tasks who have received training that gives them the ability to repair power chucks.

2.3 Danger notices:

The following notices are intended to promote your personal safety as well as prevent damage to the described product or attached devices.

In these operating instructions, the safety notices and warnings that are designed to avert dangers to the life and health of operators or repair personnel or avoid material damages are labeled with the signaling terms and pictograms defined here.

2.3.1 Work safety symbol:



You will find this symbol next to all work-safety notices in these operating instructions where there is a hazard to life and limb. Always observe these notices and proceed with special caution in these situations.

In addition to these notices, observe also the general safety and accident-prevention regulations.

2.3.2 ATTENTION! - Notice:

ATTENTION!

This symbol identifies sections of the operating instructions that deserve special attention in order to maintain compliance with the guidelines, regulations, notices, and task sequences and to prevent damage and destruction of the product.

2.4 Work safety notices:

Rotating power chucks can be hazardous if not used appropriately and not handled according to the technical safety requirements. The power chucks of type 3 QLC - AG are constructed according to the current state of technology and are operationally safe. Nevertheless, these power chucks can still represent a hazard if used **improperly** by untrained personnel or if used for an **inappropriate** application. The "**lathe - power chuck - work piece**" system is influenced to a large degree by the work piece that is being produced, which can represent a residual risk. The user must assess this residual risk.

- * ***The power chucks may be used, assembled, and repaired only by persons above the age of eighteen years who have read the operating instructions and have appropriate technical training. These persons must have received special instruction about dangers that can appear.***
- * ***These operating instructions must be read and carefully observed before assembly and start-up of the power chuck!***
- * ***Do not attempt any operation that could compromise the safety of the power chuck.***
- * ***The operator must also take the precautions necessary to ensure that no unauthorized persons work with the power chuck.***
- * ***The operator is obligated to immediately report any changes to the power chuck that compromise its safety!***
- * ***Proper use - see section 1.2!***
- * ***Any unauthorized conversions and changes that affect the safety of the power chuck are not permitted!***
- * ***The user is obligated to use the power chuck only in a technically flawless condition!***
- * ***Any work performed on the power chuck (lubrication, maintenance, etc.) must be done when the power chuck is idle!***
- * ***Always bring the drawbar cylinder to an unpressurized condition when performing maintenance or inspection tasks on the power chuck!***
- * ***For reasons of safety, use only the manufacturer's ORIGINAL assemblies and replacement parts. The use of non-original parts will terminate the warranty!***
- * ***Make sure that all protective equipment is installed before activating and working with the power chuck.***
- * ***Local safety and accident-prevention regulations always apply to the operation of the power chuck!***

3.1 Notices:

The responsible operating personnel must read, understand, and observe the operating instructions (created according to DIN V 8418).

These operating instructions refer to especially important details about the use of the power chucks. It will be possible to avoid faults on the power chucks and ensure disturbance-free operation only with the knowledge contained in these operating instructions.

* We cannot be held liable for any damages and operational disturbances that occur due to a failure to observe these operating instructions!

* If you still experience difficulties, please contact our customer service department, where someone will be happy to assist you.

Customer Service Department - see section 10.3!

* These operating instructions are valid only for the power chuck type 3 QLC - AG.

* We reserve the right to make any technical changes to the depictions and specifications in these operating instructions as these become necessary to improve the power chuck type 3 QLC - AG!

3.2 Copyrights:

The copyrights to these operating instructions is retained by the company

FORKARDT GMBH

These operating instructions are intended for use by assembly, operating, and monitoring personnel. They include regulations and drawings of a technical nature *that may be neither fully nor partially reproduced, distributed, used for competitive purposes without authorization, or forwarded to other persons or entities.*

**FORKARDT GMBH
Lachenhauweg 12
72766 Reutlingen-Mittelstadt
GERMANY**

Telephone: +49 (0) 211 2506 - 0

Fax: +49 (0) 211 2506221

Made in Germany

© 2004 COPYRIGHT FORKARDT DEUTSCHLAND GMBH

4.1 Packaging, level of disassembly:

The weight of the item and the means of transportation are decisive factors for choosing the type of packaging. The power chucks are wrapped in oil paper or transparent film in a way that prevents penetration of dust.

Always observe the symbols shown on the packaging (according to DIN 55402 part 1):

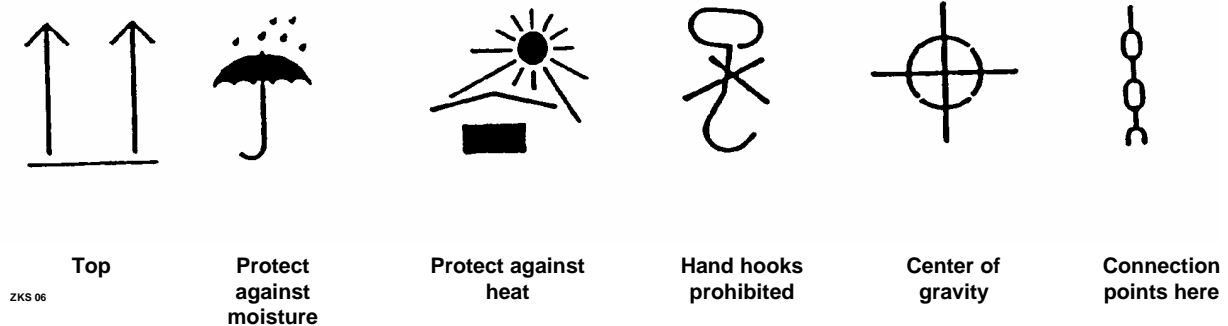

4.2 Sensitivity, storage, items included in delivery:

Proceed with care during transportation in order to prevent damages caused by external forces or careless loading and unloading.

Provide safeguards that are appropriate for the duration of the transportation.

If the power chuck will not be installed immediately after delivery, store it on a pallet in a protected location. Properly cover all parts and protect them from dust and moisture during storage.

At the time of shipment, apply a preservative (like *Metalprotector Plus* from Molykote) to all exposed parts of the power chuck.

The delivery certificates list everything included in the delivery. Check the delivery for completeness at the time of receipt.

Immediately report (by telephone and in writing) any transportation damages and/or missing parts.

5.1 Power chuck type 3 QLC – AG:

5.1 General description:

Power chucks of the type 3 QLC - AG are usually used for economical machining of shaft-type work pieces of all kinds. The power chuck type 3 QLC - AG is a rotating, power-operated triple-jaw wedge-hook chuck with centrifugal balancing and compensating chucking; it has special hard top jaws, and various centering inserts that can be installed with fixed or spring-loaded centering tips; it is suitable for external chucking of shaft-type work pieces (equipped with center drills).

Work piece example: Wheel shaft



During chucking, a loading gripper may place the work pieces (equipped on both ends with center drills) on the forward supports of the gripping device. The work piece will be gripped between the center tips of the power chuck and the tailstock. Engage the work piece on the power chuck (center tip) by adjusting the tailstock's spring-loaded center tip. A steady rest in the center of the gripping device may also be used for alignment purposes.

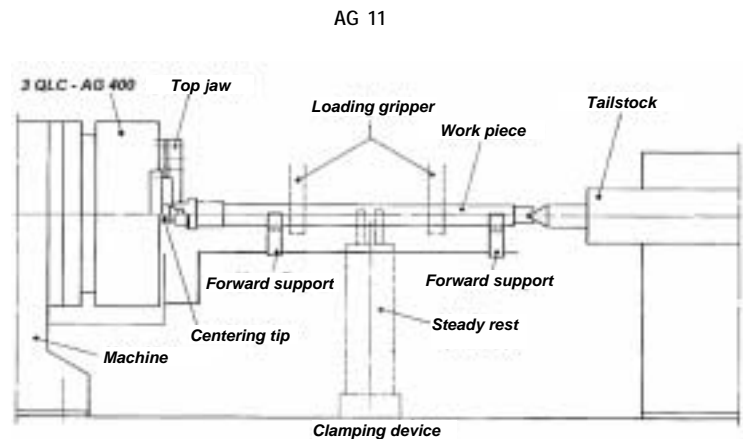

AG 12

The work piece is positioned precisely in the power chuck and thereby readied for machining. The power chuck's top jaws then grip the work piece and provide for compensation.

As with common wedge-hook chucks, a hydraulic drawbar cylinder's axial activation of the chuck piston (2) produces the tangential jaw movement. As this occurs, the work pieces are chucked radially via the hard top jaws, which are screwed in place on the base jaws (3) with pointed tothing over sliding blocks. The axially aligned activation force is transferred to the chuck piston over the tension sleeve (11), which is mounted concentrically on bearings in the chuck body.

The chuck piston "floats" on this tension sleeve and is held axially by a threaded bushing (12). This "floating" bearing permits the top jaws to adjust themselves to the work piece's "eccentric" chucking diameter before the positive connection is established.

The total stroke of the power chuck type 3 QLC – AG lies between mm and mm. The jaw stroke lies between mm and mm per jaw (depends on the size of the power chuck).

At the chucking spot, the hard top jaws are crowned according to the chucking diameter in order to avoid warping the work piece. The chucking spots themselves should be aligned **as close** as possible to the power chuck's face surface.

ATTENTION!

Do not use internally ground top jaws during compensating chucking of work pieces because the compensating effect of the power chuck will be impeded and the work piece may come out of alignment with the chuck center or fall out of the chuck!

A hydraulic drawbar cylinder with a safety-oil feed and stroke control actuates the power chuck. Mechanical or contactless limit switches on the cylinder's stroke control acknowledge the positions "Jaws free" or "Jaws closed".

5.2 Power chuck design:

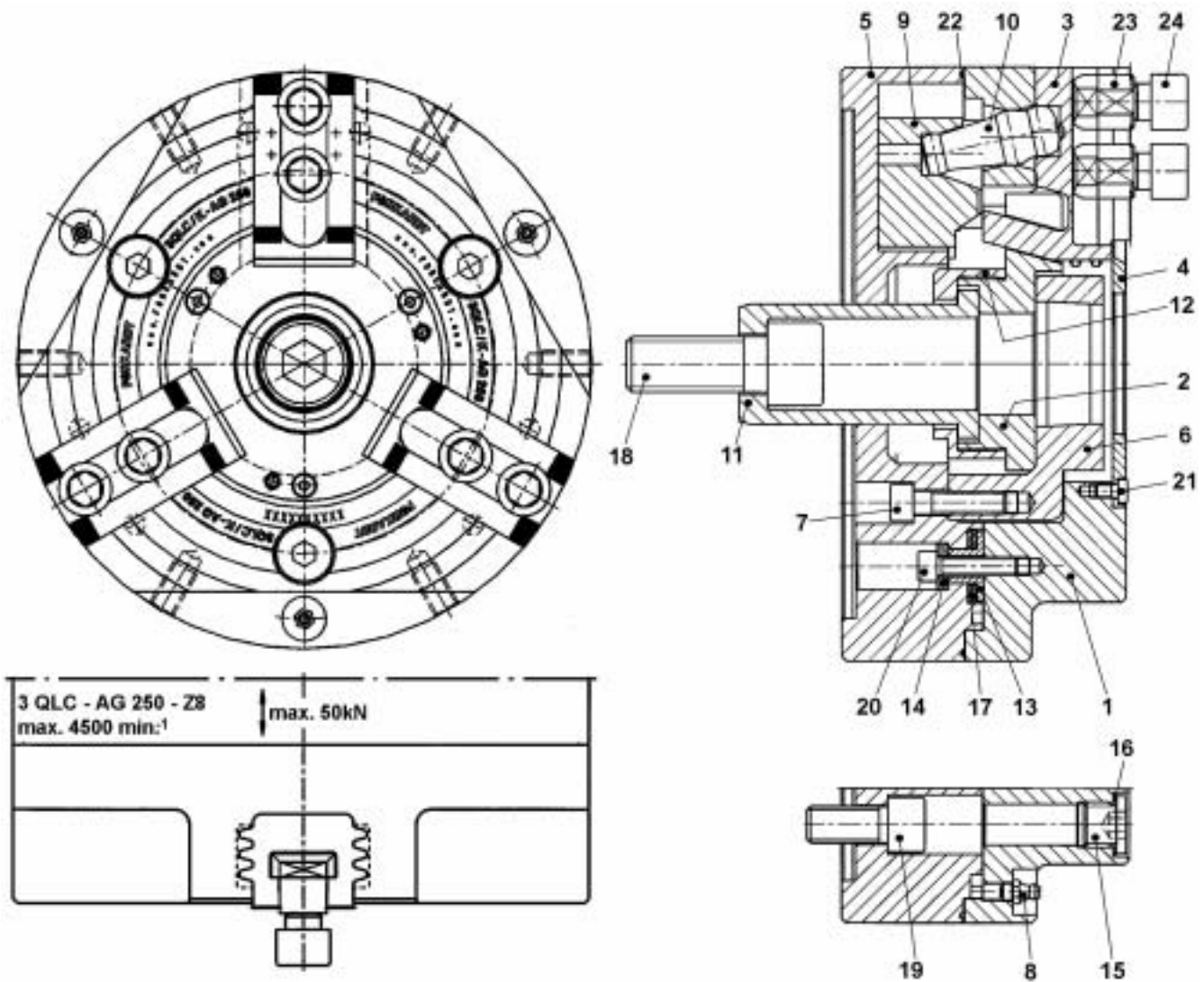

AG 12

The main components of the power chuck type 3 QLC – AG are:

- the chuck body (1), with the three special guides for receiving the base-jaws (3), the center bore for receiving the protective bushing (4), the center bore for receiving the holder (6), the center drill for receiving the chuck cap (5), and the three center bores on the base-jaw guides that facilitate sliding and guidance of the levers (10) for centrifugal balancing.
- the chuck piston (2) with the three wedge hooks for actuating the base jaws (3), the center bore for receiving the tension sleeve (11), and the center bore for guiding the locking bolts or the centering insert for the concentric-chucking version of the power chuck.
- the three base jaws (3) with pointed toothing (**standard equipment**) for positioned receipt of the top jaws.
- the chuck cap (5), standard with cylindrical centering and an O-ring (22) with three corresponding recesses for receiving the centrifugal weights (9).
- the three levers (10) for power transfer.
- the three centrifugal weights (9) for reducing the centrifugal force when the power chuck is rotating.
- the tension sleeve (11) with collar for installation into the chuck piston and for axial positioning over the threaded bushing (12).
- the tensioning bolt (18) with external threads for screwing into the connecting rod.
- the threaded bushing (12) for axial positioning of the chuck piston (2) and the tension sleeve (11).
- the six spring sleeves (13) with the plate springs (17).

Introduce the collar of the tension sleeve (11) (guided on the left side in the chuck cap (5)) into the center bore of the chuck piston and hold it axially by screwing down the threaded bushing (12). The diameter of the tension sleeve collar is about 4 mm smaller than the center bore in the chuck piston. This characteristic provides the compensating tension of the work pieces.

When assembling the internal parts of the power chuck, first introduce the base jaws (3) into the center bore of the chuck body. From inside, insert the base jaws into the jaw guides. Slide the tension sleeve (11) (connected to the chuck piston (2) via the threaded bushing) through the center bore of the chuck cap. Slide the holder (69) over the recesses located between the wedge hooks and fasten it with six machine screws (7) to the chuck cap.

Then apply lubricating grease onto the lever and slide it into the center bores of the chuck body (1) and the base jaws (3). Apply lubricating grease to the centrifugal weights (9), place them into the corresponding recesses in the chuck cap, and slide them into the appropriate position (to the levers located in the chuck body).

Apply grease to the cup springs (17), slide them onto the guide pins of the spring sleeves (13), and place them into the corresponding center bores of the chuck cap. Stick the chuck fastening bolts (19) through the corresponding center bores of the chuck cap.

Insert the chuck cap with the installed holder and chuck piston (including assembled tension sleeve) into the center bore of the chuck body and carefully slide up the chuck piston (with the wedge hook-recesses on the wedge hooks of the base jaws and the centrifugal weights on the levers). In doing so, the centering collar of the chuck cap is slid into the centering receiver of the chuck body, and the chuck cap with six machine screws (20) (attached to chuck body by an underlying washer) is slid in until the washers (14) contact the guide pins of the spring sleeves. The spring resistance of the cup springs compensates for the previously determined tolerance between the chuck cap and the chuck body (from mutual grinding of the spring sleeves to the same height). The cup springs of the cup-spring columns have the task of smoothly compensating for the extension of the top jaws during the clamping process and to provide a defined axial pull-back against the centering tip or a datum. The base jaws (3) and all other internal parts of the power chuck can be lubricated over the three funnel-type lubricating nipples AM8x1 (8) (DIN 71412) located on the face-side of the chuck body.

Slide the chuck flange with its short cone onto the short cone of the spindle head, align it with the dial gauge, and use the corresponding machine screws to fasten it to the spindle head of the machine spindle. Slide the power chuck (with its center drills) onto the centering collar of the assembled chuck flange and use the chuck attachment bolts (turn clockwise with torque wrench) to fasten it to the chuck flange.

Before fully tightening the fastening bolts in a clockwise direction, align the power chuck so that when assembly is complete the pointer on the gauging surfaces of the power chuck does not exceed a value of **0.01mm**.

Insert the protective bushing (4) into the center bore of the chuck body (1) and fasten it to the chuck body with three machine screws (21).

Always comply with the proper tightening torque for the fastening bolts. See also section 1.4, page 5.

Fasten the top jaws to the base jaws by screwing the machine screws (26) into the sliding blocks. Exact positioning is achieved by means of the pointed toothing on the base and top jaws.

After assembling the power chuck on the spindle head of the machine spindle, the center bores (through which passes the wrench for the chuck-fastening bolts) must be sealed with a plug screw (15) with an underlying sealing ring (16) in order to prevent cooling liquid from penetrating into the inner area of the power chuck.

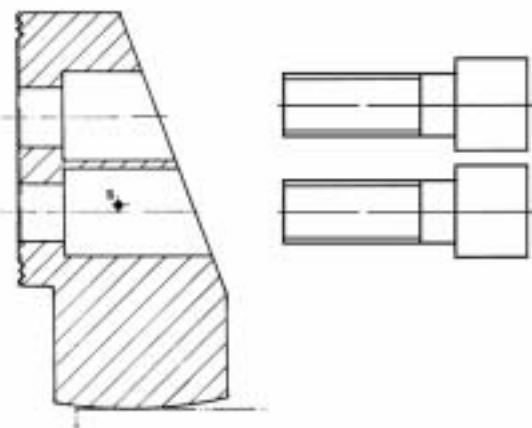

AG 14

5.3 Power chuck versions:

5.3.1 Power chuck type 3 QLC – AG, compensating chucking:

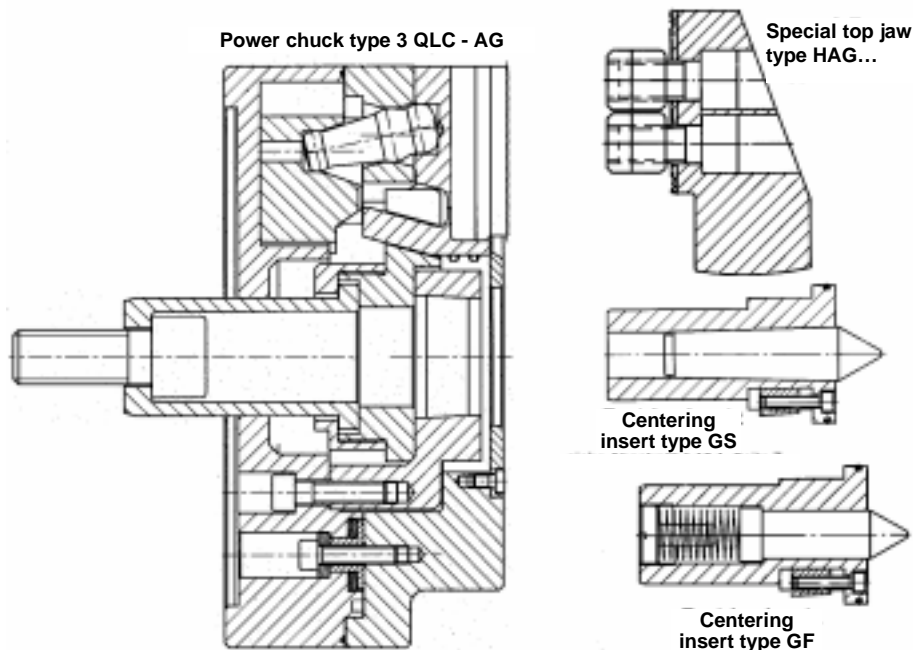

AG 15

The compensating power chuck type 3 QLC – AG consists of the components specified in figure AG 15, which must be ordered individually. For compensating chucking, two sets of top jaws with bow-shaped cutting edges are available as gripping surfaces. Special jaws (available upon request) may be needed for handling work pieces with unusual shapes.

5.3.2 Power chuck type 3 QLC – AG, concentric chucking:

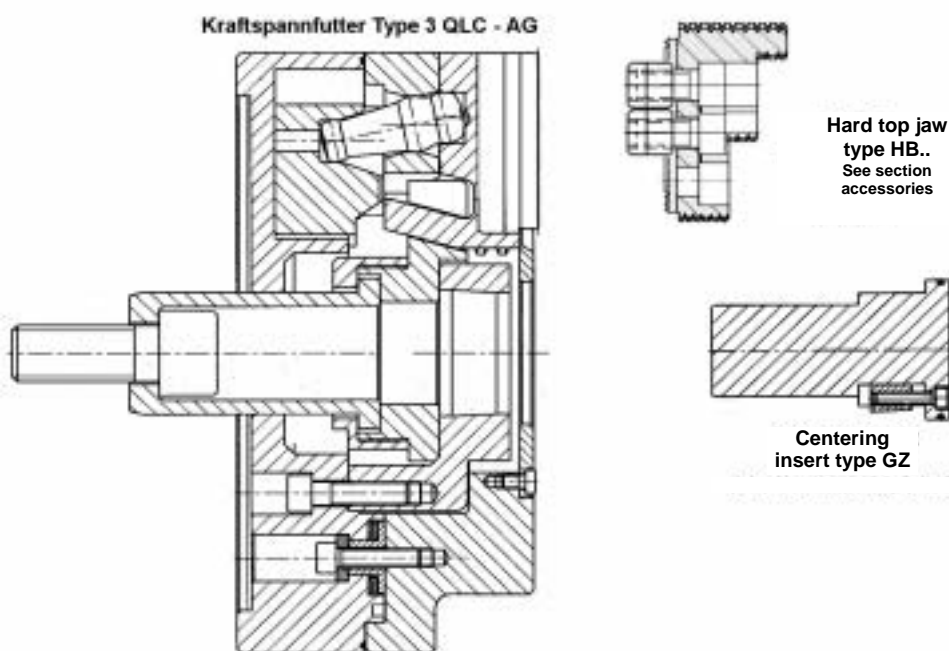

AG 16

The concentric power chuck type 3 QLC – AG consists of the components specified in figure AG 16, which must be ordered individually. Both hard (HB) and soft (WBL) top jaws are available for concentric chucking.

Chuck type	3 QLC - AG	→	175	200	250	315	400
ID No.	→				169747		
Minimum distance	P4						
Distance sliding block / tothing	P5						
Length of pointed tothing	P6						
Jaw width	Q				45		
Channel width	Q1				21		
Pointed tothing division	T						
Distance to first tooth	T1						
T sliding block					FN 232		

5.5 Centering inserts

5.5.1 For compensating chucking: With fixed tip type GS

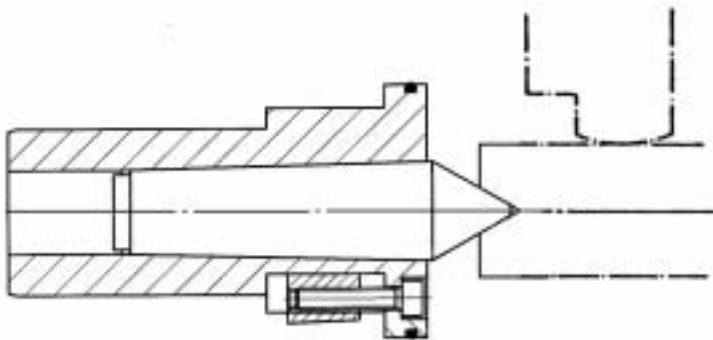

The compensating chucks type 3QLC - AG can be equipped with three different centering inserts, depending on the specific application.

Used whenever the tip of the work piece determines its length. In other words, where the tip of the work piece is also the length stop.

← See figure AG 18

AG 18

5.5.2 For compensating chucking: With spring-loaded tip type GF

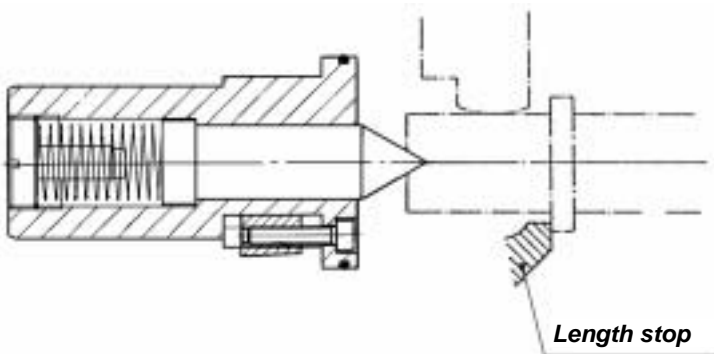

Used whenever the work piece's length is determined from the machine, for example by the tip of the tailstock or limit stop (limit stop on clamping chuck also possible).

← See figure AG 19

AG 19

5.5.3 For concentric chucking: Type GZ

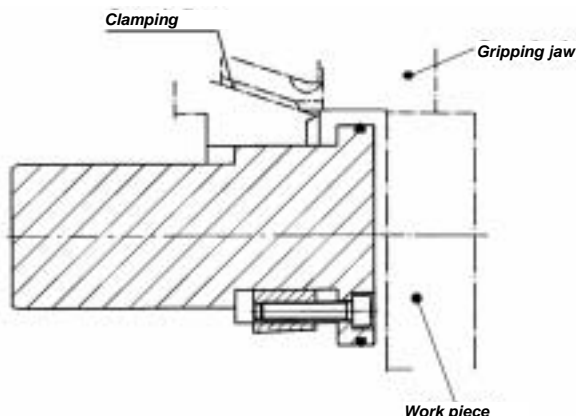

These inserts are used when the clamping chuck must be converted to concentric chucking. As a result, the clamping piston will then be guided centrally.

← See figure AG 20

AG 20

5.6 How the power chuck works:

The power chuck is actuated by a standard hydraulic cylinder with clamping stroke control. This cylinder is fastened to the cylinder flange at the spindle-end of a lathe and has the task of generating the axial force for the power chuck type 3 QLC – AG employed on the spindle head. The force is used to actuate the top jaws, to clamp work pieces. An external hydraulic system or the machine's hydraulic system supplies the drawbar cylinder with hydraulic oil.

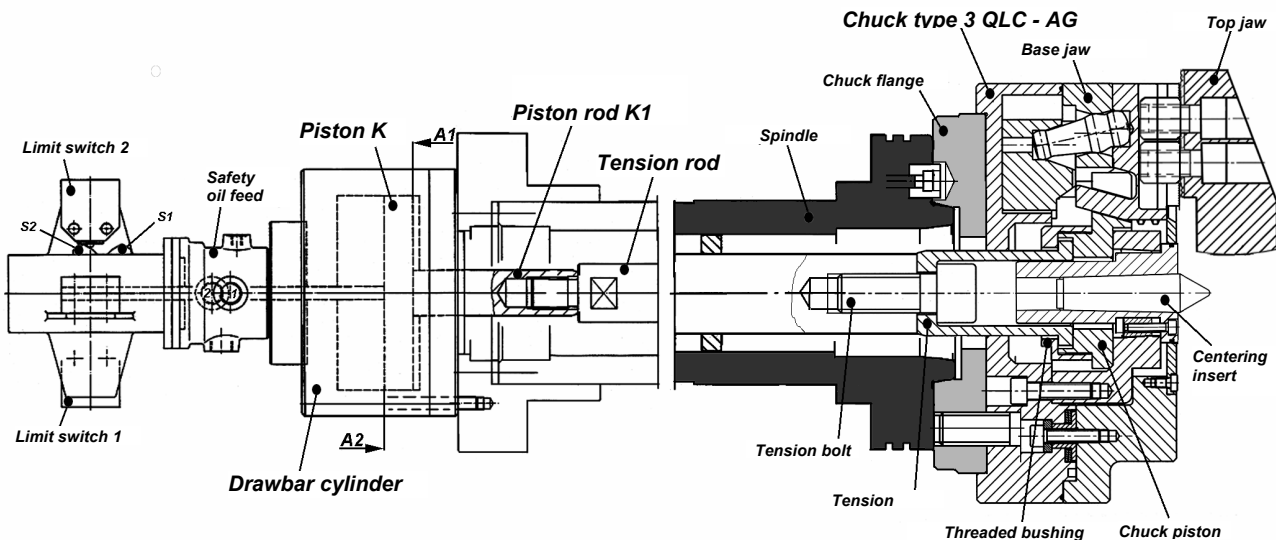

AG 21

Tubes carry the hydraulic oil to the drawbar cylinder's stationary feed housing. From there the oil is forwarded through the appropriate holes into the desired cylinder chamber (1 or 2), where it generates the clamping pressure.



You must adjust the pressure on the drawbar cylinder so that the power chuck's maximum actuation force is not exceeded.

The clamping pressure generates axial force over the corresponding piston surface. This axial force is transferred over the piston rod and the screwed-in connecting rod, through the center bore of the machine spindle, and then to the power chuck type 3 QLC – AG. The hydraulic pressure that generates the actuation force must be calibrated to the power chuck's maximum permissible actuation force and may not exceed this level. In other words, the hydraulic pressure for cylinder chamber **1 (chucking)** and cylinder chamber **2 (release)** must be adjusted accordingly.

Mechanical limit switches on the drawbar cylinder monitor the clamping stroke. The limit switches must have an internal function-monitoring capability and thereby meet the requirements of the professional association. Two limit switches are used to monitor the power chuck's clamping stroke (chucking/releasing of the work piece). Together with hydraulic-pressure monitoring, these switches ensure, according to the corresponding functional sequence, that machining of the work pieces can proceed only when the proper chucking pressure has been reached in the drawbar cylinder and the work piece has been chucked in the permissible working range of the power chuck. For example, the drawbar cylinder type **OKRJ... (FORKARDT)** complies with the professional association's testing principles. Stroke control ensures, together with the pressure monitor, that the oil pressure fed to the drawbar cylinder actually leads to increased chucking force.

It is important that the drawbar cylinder remains under a hydraulic pressure of 5 bar in order to ensure permanent lubrication of the oil feed and avoid blockage damages caused by overheating.

To adjust the top jaws to a certain chucking diameter, use the hexagon wrench (DIN 911) to loosen the jaw-fastening bolts (two full turns) and then slide the top jaw with the sliding blocks and bolts to the desired chucking diameter.

To exchange the top jaws (for example: switch from hard top jaws of type HB to soft top jaws of type WBL), use the hexagon wrench to turn the jaw fastening bolts by two full turns and then completely remove the top jaws from the base jaws.

ATTENTION!

Always clean any chips or dirt from the base jaws before removing the top jaws!

ATTENTION!

If machining of the chucked work piece is interrupted for several hours, it will be necessary to reactivate the power chuck or the drawbar cylinder.

5.6.1 Centrifugal force compensation:

One counterweight is assigned to each base jaw via a reversing lever. As the chuck rotates, the centrifugal force of the counterweight largely balances out the centrifugal force of the base and top jaws, which would otherwise lead to a significant loss of gripping force. This simple, robust, and directly-acting centrifugal-force balancing system ensures that the power chuck type 3 QLC - AG has a high gripping force.

5.6.2 Integrated lubricant reserve:

With every chucking stroke, the movement of the centrifugal weights in the rear section of the chuck is used to move lubricant to all sliding surfaces. The excess lubricant that is forced inward is centrifuged back into the reserve chambers (over the centrifugal weights) as the chuck rotates and is available again during the next chuck stroke. If needed, the lubricant reserves can be supplemented by adding lubricant through easily accessible high-pressure lubrication nipples.

The lubricating channels take the form of open channels in the individual parts. In contrast to traditional chuck types, the power chucks of type 3 QLC - AG do not have any narrow and angled lubrication bores that could slow or stop the flow of lubricant. This feature improves the reliability of the lubrication function and makes it much easier to clean and maintain the power chuck type 3 QLC - AG.

5.6.3 Sealing the power chuck:

Power chucks type 3 QLC - AG are sealed well against the escape of lubricant and to prevent functional disturbances caused by the penetration of coolant, dirt, and chips. O-rings hermetically seal the gaps between the chuck body and the chuck cap and between the centering insert and the protective bushing. All movement gaps exhibit close fits and hardened guard plates.

5.7 Safety notices:

A device that monitors chucking pressure must be present in order to ensure that a minimum gripping pressure is maintained.

The pressure monitoring device must be adjusted (and secured against false adjustments) so that the machine will start running only after an adequate minimum gripping pressure has been exceeded.

The pressure on the drawbar cylinder must be adjusted so that the power chuck's maximum actuation force is not exceeded.

The testing guidelines of the professional association specify, in addition to pressure monitoring for the drawbar cylinder, a clamping stroke monitoring device that ensures that the machine spindle drive and the feed cannot be switched on at the end of the stroke and when the power chuck is open or is forced to stop, respectively.

The machine spindle may not start running when the power chuck is completely open or completely closed (in the end positions) because the safety limit switches will stop the lathe.

The machine spindle may start running only when the chucking pressure is built up in the drawbar cylinder and the work piece has been chucked in the power chuck's permissible working range.

If the gripping energy is lost, the work piece must remain firmly chucked until the spindle comes to a stop and a signal must stop the machine spindle.

5.8 Gripping jaws:

5.8.1 General information:

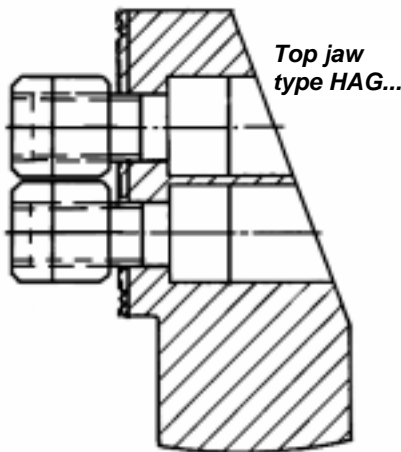

AG 22
Top jaw, for compensating chucking of work pieces.

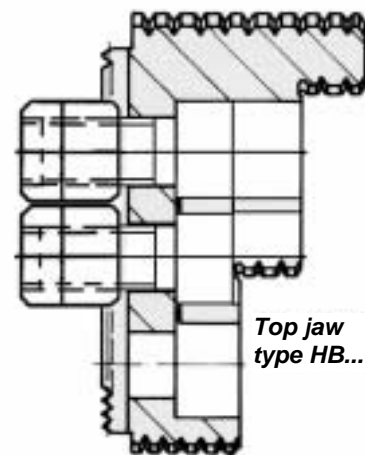

AG 23
Top jaw, for concentric chucking of work pieces.

The power chuck is the connecting element between the lathe and the work piece that will be machined. The lathe's power is transferred to the work piece at the spindle-head transitional point by the power chuck and at the connecting point between the power chuck and the work piece by the non-positive slaving of the pressed top jaws. Gripping jaws are the radially movable elements of the power chuck that hold the work piece in place during machining. The gripping jaws consist of the base jaw (the connective element to the power-producing part of the power chuck) and the top jaw, which is positively fastened by means of pointed teeth to the base jaw and therefore precisely positioned. Either hard or soft top jaws are used, depending on the type of machining and chucking (compensating or concentric) or for varying dimensions and shapes of the work pieces. The gripping jaws should be individually shaped for the best results and in order to avoid faulty gripping.

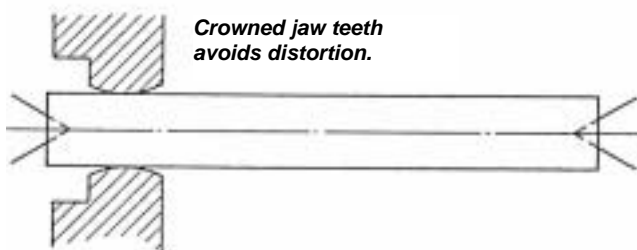

AG 24
When the work piece is especially slender and somewhat irregular on the gripping diameter, we also recommend using a jaw that is crowned in the axial direction.

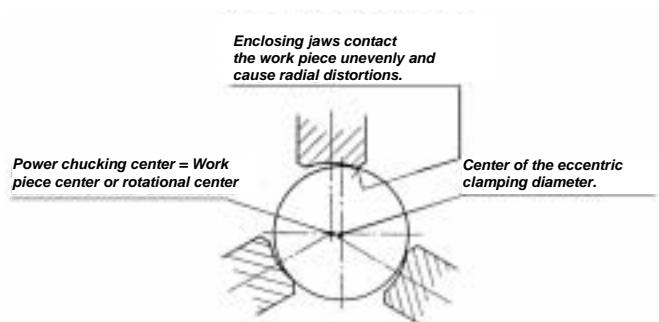

AG 25
Gripping jaws that enclose a large portion of the work piece are not recommended because they will contact the work piece unevenly and cause radial warping.

5.9

**Safety notices for top jaws:**

- * *When using self-made top jaws, make sure that the pointed teeth are properly divided. Check for distortion that arises during hardening.*
- * *Do not damage the pointed teeth of the top jaws. Screw onto the base jaws only top jaws with flawless pointed toothing in order to avoid losing chucking precision!*
- * *Use the specified gripping force to recalculate the strength of self-made top jaws.*
- * *Use only ORIGINAL sliding blocks and fastening bolts to fasten the top jaws, in consideration the required quality!*
- * *Set the lathe's speed-limiting device to the permissible speed calculated for special top jaws, because the gripping-jaw centrifugal forces that occur at higher speeds will diminish the clamping force to the point that the work pieces are no longer securely held!*
- * *When inserting a work piece into the power chuck, always move one top jaw downward in order to avoid pinching the work piece between two top jaws.*
- * *When the work piece is inserted, the stroke of the top jaws should be equal to or less than 3 mm. Design the shape of the top jaws so that you do not need a stroke greater than 3 mm to achieve the chucking position!*
- * *Make sure the jaw-fastening bolts are tight. Calculate to tensile strength (static and dynamic). Use only screws of the quality 10.9, DIN 267!*
- * *In the case of external chucking, arrange all jaw-fastening bolts as far inside as possible!*

5.13

**Safety notices:**

- * *The work piece clamping force specified in section 1.4, page 5 (assuming a permissible maximum actuation force) will be reached only when the power chuck and the drawbar cylinder are in a flawless condition!*
- * *The machine operator must inspect the gripping condition of the work piece and be confident that it is acceptable before starting the machining cycle.*
- * *If the gripping force (as measured by a gripping force measurement device like the SKM 1200/1500) falls below the specified value, the power chuck requires maintenance!*
- * *Only safety limit switches (with mechanical, forcefully-activated, normally closed contacts) that comply with the VDE 0113 / 12.73, section 7.1.3 requirements for safety limit switches may be used to monitor chucking stroke.*
- * *If other control devices like contactless limit switches are used in place of safety limit switches, they must achieve the same level of safety.*
- * *The protective effect must be preserved even if there are disturbances in the control devices or in the associated switches or if the power supply for these control devices fails.*
- * *The contactless limit switches must have an internal functional-monitoring capability and thereby meet the requirements of the professional association.*
- * *Check the electrical clamping-stroke control for proper functionality. The limit switches must switch reliably before reaching the two end positions.*
- * *Machining of the work pieces may proceed only when the gripping pressure has been established in the drawbar cylinder and the chucking was done in the power chuck's permissible working range.*
- * *The clamping device may not be switched on when the power chuck is completely open or completely closed (in the end positions) because the safety limit switches will stop the lathe.*
- * *If the gripping energy is lost, the work piece must remain firmly chucked until the spindle comes to a stop and a signal must stop the machine spindle.*
- * *When using gripping devices where disconnection of the energy and stopping of the machine spindle can lead within a short time to dangerous loosening of the work piece, always observe the following:*

ATTENTION!

The work piece may disengage from the power chuck after disconnection of the clamping energy!

- * *See DIN 24346 (corresponds to ISO 4413) for design basics of hydraulic systems!*

5.14 Safety requirements for power-operated clamping devices:

The testing principles of the professional associations as well as DIN, VDE, and VDI guidelines define the safety conditions for operating power-operated clamping devices. Corresponding measures, as listed to the right, ensure compliance with the individual testing requirements. For this purpose, we have developed individual hydraulic and pneumatic controllers that fulfill the requirements of the previously mentioned testing principles and guidelines for all of our power clamping devices. The following overview shows how these individual components work together.

See also the brochure number 601.01.4D.

- o - - - mechanical solution
- o — electrical solution

Test Condition:	Ensured By:	48748
The machine spindle may start running only when the full gripping pressure has been established in the drawbar cylinder.	Pressure switches in the gripping lines.	— t - - - u
The machine spindle may start running only when the chucking was done in the permissible area of the jaw stroke. The chucking can be released only when the machine spindle is stopped.	Electric limit switches monitor clamping stroke on the actuation cylinder. Stationary detection on the machine spindle.	— v - - - w — x - - - y
If the gripping energy is disconnected, the work piece will remain firmly clamped until the spindle stops.	Unlockable return valves in the actuation cylinder.	- - - z
If the power fails and then is restored, there will be no changes to the switching settings.	Impulse-controlled stroke valve with indexed end positions.	— { - - -
When the gripping energy is disconnected, a signal will be given to automatically or manually stop the spindle.	Pressure switch in the gripping line.	- - - }

Safe connection of a power-operated clamping device

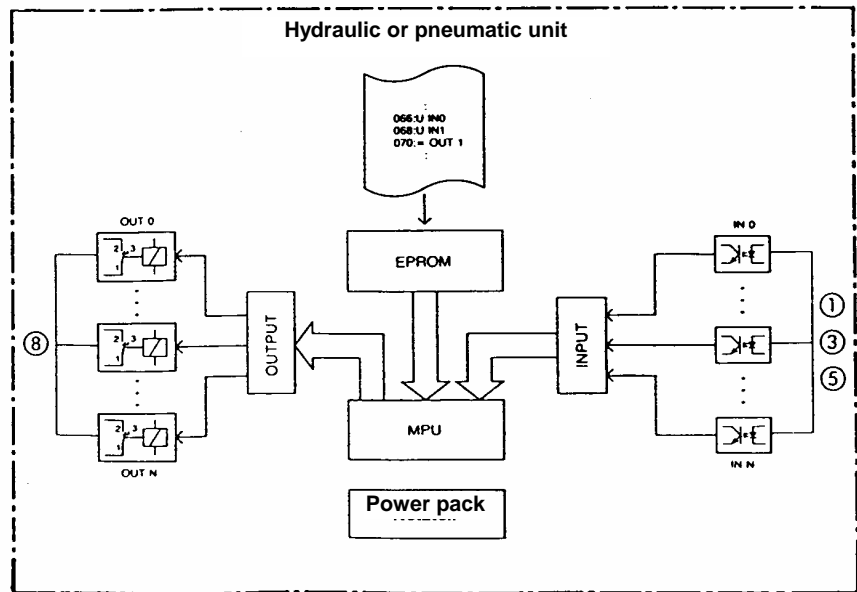
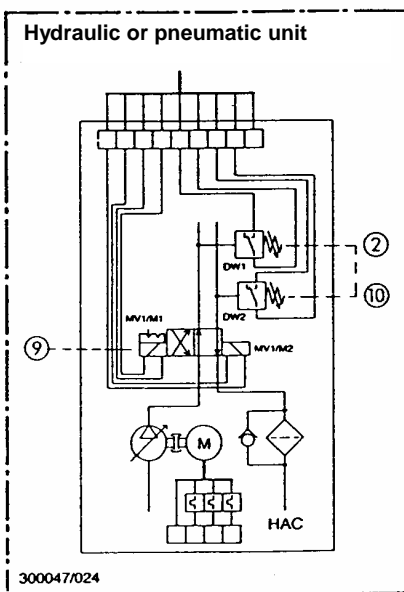
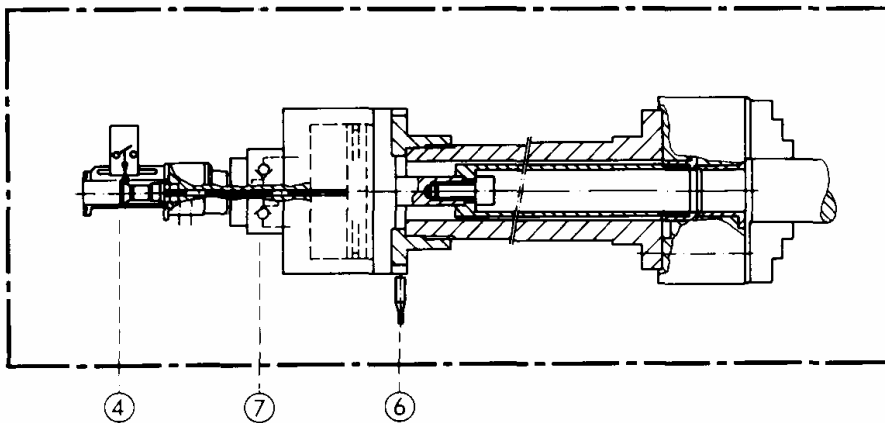

Hydraulic or pneumatic unit

6.1 General information:

The power chuck is connected to the work piece by means of non-positive action. In other words, power is transferred by the gripping jaws (base jaws with top jaws) pressing onto the work piece. The pressing force needed to produce this non-positive connection is called "gripping force". Several things directly or indirectly influence the gripping force:

- * Variable coefficients of adhesion between the work piece and the top jaws.
- * Ratio of gripping diameter to working diameter.
- * Amount of cutting force on the cutting tool.
- * Overhang of the top jaws from the clamping point.
- * Reduction of gripping force caused by the centrifugal force of the gripping jaws during external clamping.

Rotating clamping tools are subject to the influence of centrifugal force, which increases with the square of the rotational speed. In the case of external chucking, the centrifugal forces work against the clamping force. The opposite applies to internal chucking. At a high spindle speed, the gripping jaws' remaining force for holding the work piece depends on the amount of gripping force when stopped, the weight of the top jaws, and their center-of-gravity radius.

6.2 Gripping force:

The maximum gripping force F_{spo} specified in the table in section 1.4, page 5 is achievable only under favorable conditions. The required conditions are:

- Flawless condition of the power chuck
- Optimal lubrication of all sliding surfaces
- Maximum actuation force
- Short overhang of the top jaws
- Stopped $n = 0$ (or low speed)

Use a static gripping-force measuring device (like the SKM 1200 / 1500) to measure the gripping force when stopped. SKM 1200 / 1500, see also brochure 930.10.02D.

Refer to the F_{spo} table values (section 1.5) when performing strength calculations like those needed to design special top jaws.



AG 67

6.2.1 Operational gripping force F_{sp} :

The operational gripping force **F_{sp}** is the total gripping force (daN) of **all** gripping jaws with the lathe running and represents a minimum value for the usable gripping force under normal working conditions.

Normal working conditions are when the power chuck:
is in flawless condition and
has adequate lubrication on all sliding surfaces

When in good condition, a power chuck will exceed the calculated value for F_{sp} . The gripping force during standstill is derived from the power chuck specifications. However, the gripping force alone is not sufficient for operation. The top jaws have a strong influence on the operation of a power chuck. The proper choice of top jaw must be determined for every individual case. The top jaws influence the gripping force and therefore also the speed. The centrifugal force of the power-chuck gripping jaws can have such a strong influence on the gripping force that this factor must always be taken into consideration at higher speeds. On the power chuck type 3 QLC - AG, centrifugal weights applied by levers counteract the centrifugal force generated by the base and top jaws. As a result, the gripping forces acting upon the work piece remains nearly constant. The gripping force F_{spo} needed when the lathe is stopped must be high enough so that the gripping force that will be needed to machine the work piece will be available at the selected speed. On the power chuck type 3 QLC - AG, the **C4** chuck constant accounts for the influence of the lever-actuated centrifugal weights.

The following formula can be used with the type 3 QLC - AG power chuck to calculate the operational gripping force and the actual gripping force loss ΔF_{sp} :

$$F_{sp} = F_{spo} - \Delta F_{sp} + C_4 \times n^2 \quad i$$

The existing gripping force F_{spo} at standstill (speed $n = 0$) is determined as follows:

$$F_{spo} = \frac{C_1}{C_2 + a} \times F_{ax} \quad j$$

The loss of gripping force ΔF_{sp} over the gripping jaws:

$$\Delta F_{sp} = 0.0008 \times (C_3 + Ma) \times n^2 \quad - \text{ for external chucking} \quad k$$

The influence of the lever-actuated centrifugal weights:

$$C_4 \times n^2 \quad + \text{ for external chucking} \quad l$$

From this we can find the operational gripping force F_{sp} :

$$F_{sp} = \frac{C_1}{C_2 + a} \times F_{ax} - 0.0008 \times (C_3 + Ma) \times n^2 + C_4 \times n^2 \quad m$$

The total centrifugal moment Ma is calculated according to this formula:

$$Ma = \frac{\frac{\text{®}D_{sp}}{\text{©} \text{™} 2} \pm Y_{AB}}{1000} \times G \times i \quad n$$

Terminology used in the formulas:

F_{sp} = Operational gripping force [daN], the total gripping force of all jaws when running

C_1, C_2, C_3, C_4 = Chuck constants

F_{ax} = Max. actuation force [daN]

n = Speed [min^{-1}]

Ma = Total centrifugal moment of the gripping jaws [kgm]

D_{sp} = Gripping diameter [mm]

Y_{AB} = Center-of-gravity distance of the top jaw from the gripping diameter [mm]

a = Jaw overhang [mm]

i = Number of gripping jaws

G = Weight of one gripping jaw [kg]

R_a = Center-of-gravity distance of the top jaw from the chuck center [mm]

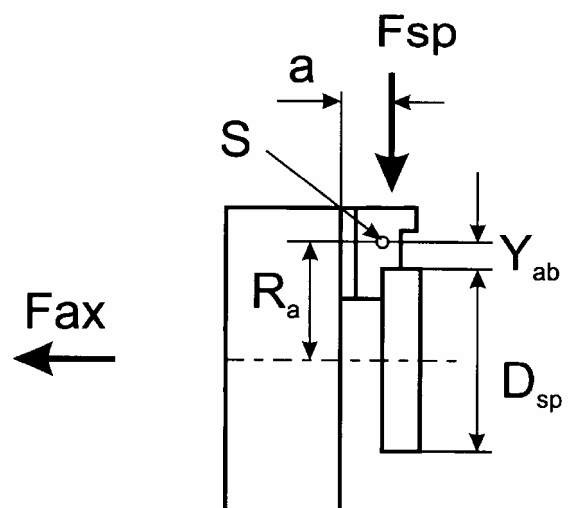

AG 68

Check to make sure that the available operational gripping force is sufficient for the specific machining application.

The actual centrifugal moment for the special jaws constructed of soft top jaws type WBL or other special top jaws must be determined **from the weight** (by weighing them) **and the center-of-gravity distance R_a** , starting from the chuck center.

See figure AG 69 →

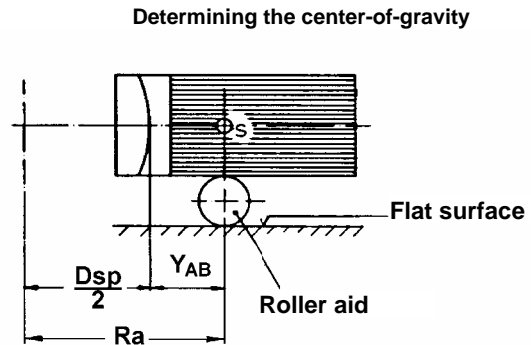

AG 69

At high speeds, the weight of the soft top jaws must be reduced as much as possible, providing for a short jaw overhang.

When the jaws are ready for usage, find their weight and center-of-gravity and check whether the power chuck's remaining operational gripping force is sufficient for the intended machining process. Refer to formula 5 on page 35!

If the calculated operational gripping force F_{sp} is not sufficient for the intended machining, then the speed must be reduced (see formula 8 on page 38) or the jaws must be made lighter (see formula 7, page 38).

The permissible power chuck speed with the respective top jaws or the gripping force progression must be calculated for every machining case.

6.3



Safety notices:

- * **Check if the power chuck's gripping force is sufficient for the intended machining under the selected operational conditions.**
- * **The calculated gripping-force values will be achieved only when the power chuck is in flawless condition (the gripping force may be higher when the chuck is freshly lubricated).**
- * **Use light top jaws at high speeds.**
- * **When the power chuck is rotating, the operational gripping force must be measured with a dynamic gripping force meter like the FORSAVE D.**
- * **Calculate the dynamic loss of gripping force for every configuration process and make sure that the gripping force is sufficient for the machining task.**
- * **If the gripping force, as measured by a gripping force meter, sinks below the calculated value, then the power chuck must be relubricated. See also section 9.2!**
- * **According to the regulations of the professional association, any work with rotating tools at high rotational speeds may be done only under sufficiently dimensioned protective doors! The protective doors must be closed and locked while the machine is running!**

6.4 Calculation examples:

Example 1:

Power chuck type		: 3 QLC – AG 250
Max. actuation force Fax		: 5000 daN
Jaw configuration		: HAG 44-45-30-S12
Gripping diameter	Dsp	: 80 mm
Working speed	n	: 2400 min ⁻¹
Chuck constant C1		: 916
Chuck constant C2		: 398
Chuck constant C3		: 0.20
Chuck constant C4		: 0.0005
Jaw overhang a		: 25 mm
Number of jaws i		: 3

How high is the gripping force at stop when chucking the work piece (n = 0) and at working speed n = 2400 min⁻¹ ?

$$D_{sp} = 80\text{mm}$$

$$Y_{AB} = 65\text{mm}$$

$$\text{Jaw weight } G = 0.68 \text{ kg / jaw}$$

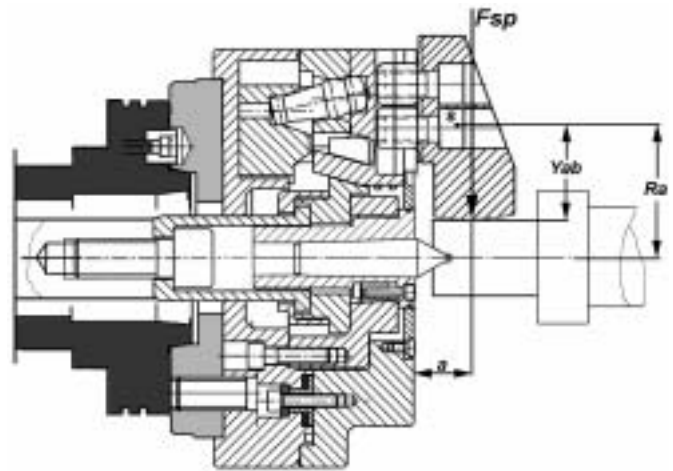

AG 70

Center-of-gravity radius Ra :

$$Ra = \frac{D_{sp}}{2} + Y_{AB} = \frac{80}{2} + 65 = 105\text{mm}$$

Total centrifugal moment Ma:

$$Ma = \frac{Ra \times G \times i}{1000} = \frac{105 \times 0,68 \times 3}{1000} = 0,214\text{kgm}$$

Gripping force at standstill (n = 0):

$$F_{spo} = \frac{C_1}{C_2 + a} \times F_{ax}$$

$$F_{spo} = \frac{916}{398 + 25} \times 5000 = 10827\text{daN}$$

Gripping force at working speed n = 2400 min⁻¹:

$$F_{sp} = F_{spo} - 0.0008 (c_3 + Ma) \times n^2 + c_4 \times n^2$$

$$F_{sp} = 10827 - 0.0008 (0.2 + 0.214) \times 2400^2 + 0.0005 \times 2400^2$$

$$F_{sp} = 10827 - 1907 + 2880$$

$$F_{sp} = 11800 \text{ daN}$$

Example: Material 42 CrMo 4V

la = 60mm	Dsp = 160mm	v = 250m / min
a = 10mm	μsp = 0.35	nz = 2400 min ⁻¹
s = 0.63	Sz = 2	Fspz = 5000 daN
dz = 30mm	Ks = 1919 N / mm ²	

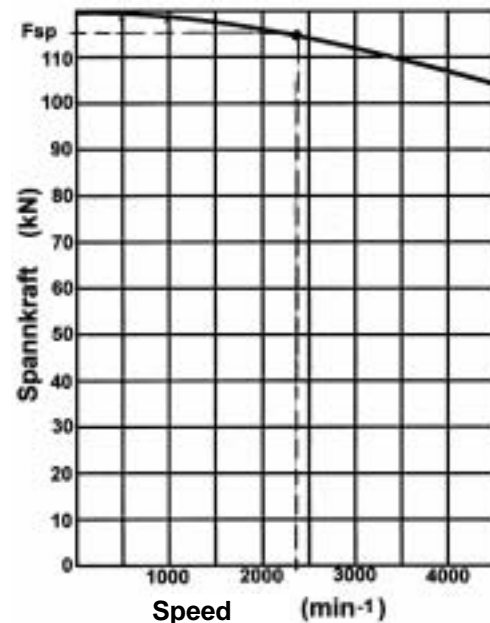

AG 71

Example 2:

Power chuck type : 3 QLC – AG 250
 Max. actuation force Fax : 5000 daN
 Jaw configuration : Special top jaw
 Required gripping force Fspz at working speed : 10000 daN
 Gripping diameter Dsp : 80 mm
 Working speed n : 2400 min⁻¹
 Chuck constant C1 : 916
 Chuck constant C2 : 398
 Chuck constant C3 : 0.20
 Chuck constant C4 : 0.0005
 Jaw overhang a : 35 mm
 Number of jaws i : 3

Weight G of the special top jaw = 2.8 kg / jaw
 Gripping diameter Dsp = 80mm
 Yab: 68.5 mm
 Center-of-gravity distance Rs = 108.5 mm



Total centrifugal moment Ma:

$$Ma = \frac{Rs \times G \times i}{1000} \quad Ma = \frac{Rs \times G \times i}{1000}$$

$$Ma = \frac{108,5 \times 2,8 \times 3}{1000} = 0,911 \text{kgm}$$

Gripping force at standstill (n = 0):

$$F_{spo} = \frac{C1}{C2 + a} \times Fax$$

$$F_{spo} = \frac{916}{398 + 35} \times 5000 = 10577 \text{daN}$$

Gripping force at working speed n = 2400 min⁻¹:

$$F_{sp} = F_{spo} - 0,0008 (c3 + Ma) \times n^2 + c4 \times n^2$$

$$F_{sp} = 10577 - 0,0008 (0,2+0,911) \times 2400^2 + 0,0005 \times 2400^2$$

$$F_{sp} = 10577 - 5119 + 2880$$

$$F_{sp} = 8338 \text{ daN}$$

Calculation of the permissible values:

$$Ma_{zul} = \frac{F_{spo} - F_{spz} + c4 \times n^2}{0,0008 \times n^2} \quad \textcircled{7}$$

$$Ma_{zul} = \frac{10577 - 10000 + 2880}{0,0008 \times 2400^2}$$

$$Ma_{zul} = 0.750 \text{ kgm}$$

Since the special top jaw's permissible centrifugal moment Ma_{zul} is exceeded, you must use the following formula to determine the permissible speed.

$$n_{zul} = \sqrt{\frac{F_{spo} - F_{spz} + c4 \times n^2}{0,0008 \times Mc}} \quad \textcircled{8}$$

$$Mc = Ma + C3 \quad \textcircled{9}$$

$$Mc = 0.911 + 0.2 = 1.111 \text{ kgm}$$

AG 72

Example: Material 42 CrMo 4V

la = 60mm Dsp = 160mm v = 250m / min
 a = 2mm μsp = 0.35 nz = 2400 min⁻¹
 s = 0.25 Sz = 2 Fspz = 10000 daN
 dz = 30mm Ks = 2249 N / mm²

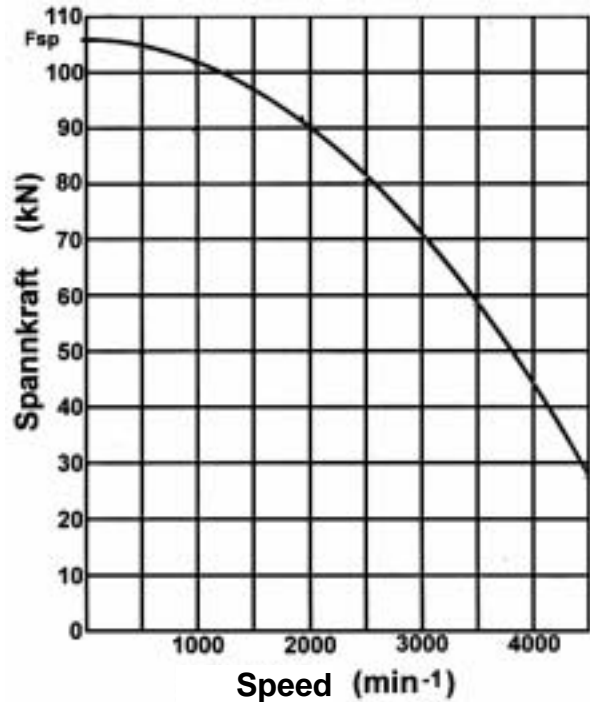

AG 73

$$n_{zul} = \sqrt{\frac{10577 - 10000 + 2880}{0,0008 \times 1,111}}$$

$$n_{zul} = 1972 \text{ min}^{-1}$$

The working speed must be reduced to at least 1972 min⁻¹ in order to achieve sufficient gripping force during machining!

6.5 Calculation of the gripping force F_{spz} necessary for the machining process:

The necessary gripping force must be determined for every machining operation. If the gripping tool is not able to produce this gripping force (in consideration of the safety factors described in VDI 3106), then you must determine the permissible speed or the permissible gripping cross section.

Here is one example:

A solid steel work piece (without center bore) will be machined. It has a gripping diameter $D_{sp} = 60$ mm, a rotational diameter $d_z = 50$ mm, and a gripping cross section. Main cutting force is $F_s = 1200$ daN. Machining speed is 2760 min^{-1} . In order to avoid damages, non-hardened jaws that are machined to the gripping diameter will be used. This produces a gripping coefficient of $\mu_{sp} = 0.1$. We assume a safety factor S_z for the machining specifications of $S_z = 2$.

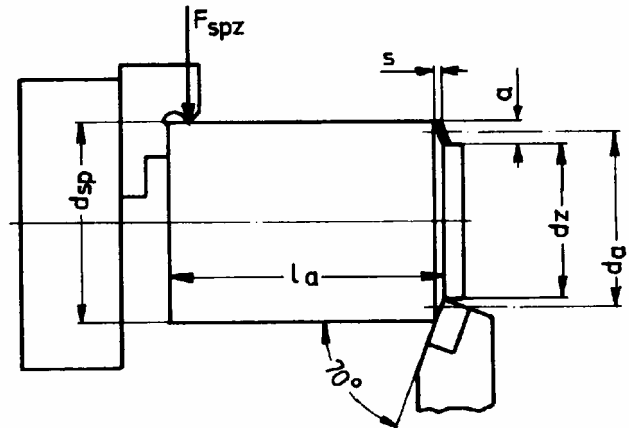

AG 74

The gripping force loss ΔF_{sp} will be 2000 daN . The example demonstrates:

- In consideration of the gripping force loss ΔF_{sp} , a gripping force of at least

$$F_{spmin} = F_{spz} + \Delta F_{sp} = 2000 + 2000 = 4000 \text{ daN}$$

is necessary when the tool-machine spindle is stopped. The main cutting force F_s , which is calculated from the gripping cross section and the specific cutting force, exerts the main influence on the gripping force.

$$F_s = a \times s \times k_s$$

The following applies to the gripping force needed for machining:

$$F_{spz} = \frac{F_s \times d_z}{\mu_{sp} \times d_{sp}} = \frac{a \times s \times k_s \times d_z}{\mu_{sp} \times d_{sp}} \quad 1)$$

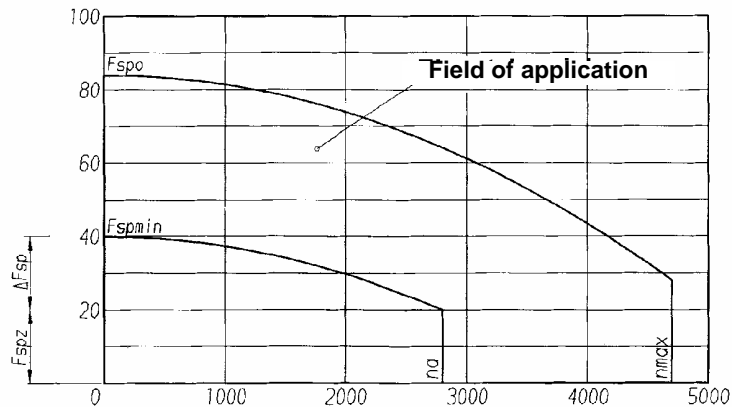

AG 75

Terminology used in the formulas:

l_a = Work piece overhang

a = Gripping depth

s = Feed

K_s = Specific cutting force

d_z = Machining diameter

d_{sp} = Gripping diameter

μ_{sp} = Gripping coefficient

F_s = Main cutting force

Machining forces will increase with blunt-end cutting tools. We recommend an additional safety coefficient $S_z = 2$ in order to cover all uncertainties in the machining operation.

Gripping Coefficient μ_{sp}				
Jaw configuration	Material	Work piece surface at the gripping point		
		▼▼▼	▼▼, ▼	~
 Plain jaws	Steel	0.1	0.15	- 1)
	Al	0.1	0.14	-
	Ms	0.09	0.14	-
	GG	0.08	0.12	-
	Steel	0.12	0.20	0.32
 Paving stone jaws 2)	Al	0.11	0.19	0.30
	Ms	0.11	0.18	0.27
	GG	0.10	0.16	0.26
	Steel	0.25	0.35	0.50
	Al	0.24	0.33	0.48
 Rough machining jaws 2)	Ms	0.23	0.32	0.45
	GG	0.20	0.28	0.40

1) Avoid; smooth jaws are suitable only for machined gripping surfaces.

2) Imprints may appear on the work piece, depending on the gripping force.

The gripping force must be increased by the tilting influence that results from the distance la.

You can forgo consideration of the tilting forces if the work piece is supported by a tailstock or if the work piece does not protrude beyond the jaws by more than 0.5 x dsp.

You can use the following formula to calculate the approximate required gripping force Fspz:

$$F_{spz} = S_z \times \frac{a \times s \times K_s \times dz}{\mu_{sp} \times dsp} \times (1 + 4 \times \frac{la}{dsp})$$

The formula includes the tilting factor:

$$(1 + 4 \times \frac{la}{dsp})$$

This equation is not applicable to offset work pieces whose gripping diameter is significantly smaller than their machining diameter.

1) This formula does not require the components "feed force Fv" and "passive force Fp". These components are included in the safety factor Sz!

Specific cutting force Ks (N/mm ²) with feed s and adjustment angle 70 ° (according to König, Essel)									
Material number	Material	Strength B N / mm ²	at v= m/min	Feed s (mm)					
				0.16	0.25	0.40	0.63	1.00	1.60
1.0401	C15G	373	100	2482	2189	1918	1687	1481	1298
1.0501	C35G	490	100	2577	2237	1927	1668	1441	1241
1.0532	St50-2	559	100	2561	2248	1959	1716	1499	1307
1.0632	St70-2	824	100	2877	2492	2142	1851	1595	1371
1.0711	9S20	373	100	1609	1553	1497	1444	1393	1342
1.1181	Ck35V	622	100	2574	2266	1982	1741	1527	1335
1.1191	Ck45V	765	100	2524	2253	1999	1781	1584	1405
1.1221	Ck60V	873	100	2548	2296	2058	1851	1662	1490
1.3505	100Cr6G	624	100	2904	2558	2239	1968	1726	1510
1.4113	X6CrMo17G	505	100	2378	2107	1854	1638	1445	1272
1.4305	X12CrNiS18.8	638	350	2596	2192	1835	1545	1296	1085
1.5752	14NiCr14BF	658	100	2249	2012	1790	1598	1424	1266
1.5919	15CrNi6	510	100	2271	2051	1842	1661	1494	1342
1.5920	18CrNi8G	578	100	2360	2095	1847	1636	1446	1276
1.7131	16MnCr5G	510	100	2641	2244	1891	1603	1354	1141
1.7147	20MnCr5G	568	100	2452	2174	1915	1694	1495	1317
1.7225	42CrMo4V	1138	100	2428	2249	2075	1919	1773	1635
1.8515	31CrMo12V	1060	100	2678	2419	2173	1960	1764	1585
1.8519	31CrMoV9V	931	100	2507	2265	2036	1836	1653	1485
3.1354	AlCuMg2	15Hv10	200	953	849	752	668	593	525
--	G-AlMg4SiMn	260	200	829	729	636	558	--	--
3.3561.01	G-AlMg5	75HV10	200	886	797	713	641	574	514
0.6020	GG-20	178HB	200	1687	1444	1227	1047	892	757
0.6030	GG-30	206HB	100	1919	1595	1313	1088	899	740
0.7050	GGG 50	194HB	200	1840	1606	1392	1213	1053	913

6.6 Permissible Clamping Length:

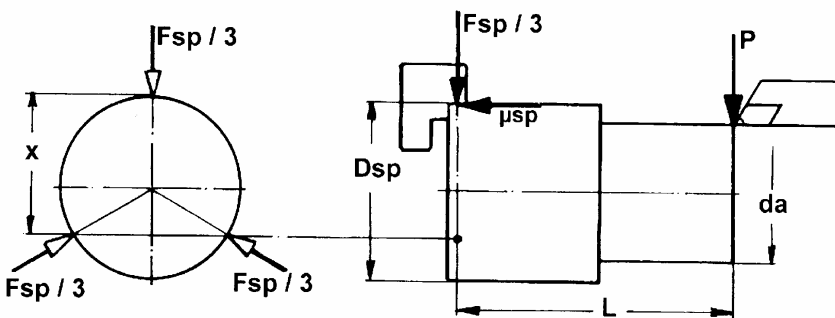

AG 79

This includes:
 $X = 0.75 D_{sp}$
 $F_{sp} = \text{Total gripping force} = \Sigma \text{ jaw forces}$
There is simple security against sudden release of the cutting force components P when the frictional force $\mu_{sp} \times F_{sp} / 3$ and P are in equilibrium.

$$1) P \times L = \mu_{sp} \times F_{sp} / 3 \times X = 0.25 \times F_{sp} \times D_{sp} \times \mu_{sp}$$

The gripping force required to prevent tilting out:

$$F_{sp1} = P \times \frac{4 \times L}{D_{sp} \times \mu_{sp}}$$

$$P_{max} = F_{sp} \times \frac{D_{sp} \times \mu_{sp}}{4 \times L}$$

The gripping force required for slaving:

$$F_{sp2} = P \times \frac{da}{D_{sp} \times \mu_{sp}}$$

The required gripping force:

$$F_{sp} = S \times \frac{P}{\mu_{sp}} \times \frac{(da + 4 \times L)}{D_{sp}}$$

S = Safety factor

Permissible clamping length at a specified gripping force:

$$L = 0.25 \times (D_{sp} \times \frac{F_{sp} \times \mu_{sp}}{P \times S} - da)$$

7.1 Steps to take before starting assembly:

7.1.1 Checking the spindle head for receipt of the chuck flange:

Use a dial gauge to check the receiving surfaces on the spindle head in order to achieve high truth of running of the power chuck.

Truth of running of the receiver centering: **max. 0.005 mm.**

Axial runout of the bearing surface: **max. 0.005 mm.**

Use a straight-edge to check the end face for evenness.

The surface of the end face must be deburred and clean at the center bores.

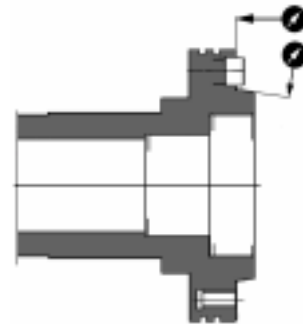

AG 80

7.1.2 Checking the assembled chuck flange:

- The power chuck has a centric receiver. To facilitate direct receipt of the power chuck on the machine spindle with a short cone according to DIN, ISO and ASA standards, it is necessary to attach a corresponding chuck flange (see also section 5.15.1, page 27) on the lathe's spindle head.
- If the user installs the chuck flange himself, the chuck flange must be finish-processed on the machine spindle and counterbalanced before assembly of the power chuck.
- Remove any dirt or chips from the machine spindle. Clean the centering receiver and bearing surface of the chuck flange.
- After assembling the chuck flange, be sure to check the truth of running and axial runout, as described under section 7.1.1.
- Use a straight-edge to check the end face for evenness.
- Thread taps for the fastening bolts must be countersunk in a way that the threads cannot be removed.
- The power-chuck screw surface may not be crowned or hollow.
- The flange must contact the entire surface!

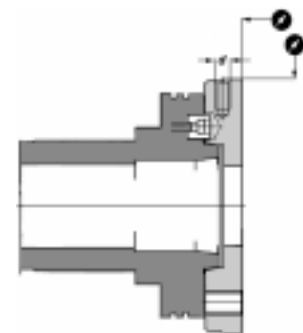

AG 81

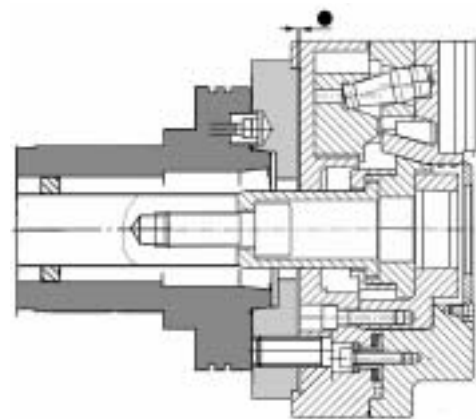

AG 82

§ Incorrect!

ATTENTION!

Make sure that the outside edge of the power chuck does not come into contact.

- Threads for screwing in counterbalance weights must be provided on the chuck flange. Depending on the size of the power chuck, these threads must be between M8 and M16 in size with thread depth of no more than 2d.
- Turn the outside of the chuck flange so it is about 1 mm smaller than the centering diameter of the power chuck receiver.

See figure AG 83

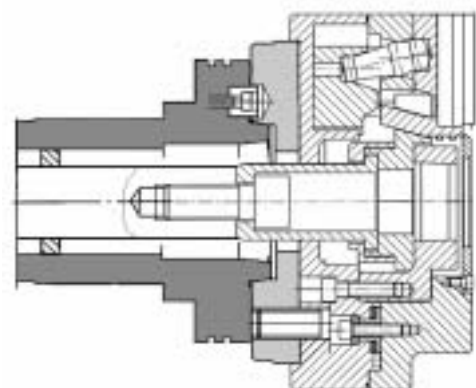

AG 83

Correct!➡

7.2 Configuration of the connecting rod:

A connecting rod provides the connection between the drawbar cylinder and the power chuck. Pay special attention to the following points when installing the connecting rod:

- * *Dimension the connecting rod according to the expected loads.*
- * *Turn the connecting rod on all sides to avoid improper balancing.*
- * *Produce the connecting rod from a material with tensile strength of at least 100kp/mm², for example 42CrMo4V.*
- * *Dynamically balance the connecting rod in two levels, whereby the permissible residual amount of unbalanced mass on the outside diameter per level may not exceed 5 gm.*

ATTENTION!

The connecting rod must be in alignment! Both threads of the connecting rod must run true to each other! Do not permit any skewed threads!

The cylinder piston's stop to the right must always be in the drawbar cylinder, not in the power chuck. Therefore, move the drawbar cylinder piston to the far right position before assembling the power chuck!

Adjust the length of the connecting rod so that the dimension "E" is achieved in the shown position.

Dimension "E" is the measured distance from the power chuck's bearing surface to the tension sleeve front edge (power chuck piston in the right position).

Use Loctite 242 to secure the connecting rod in the drawbar cylinder's piston rod!

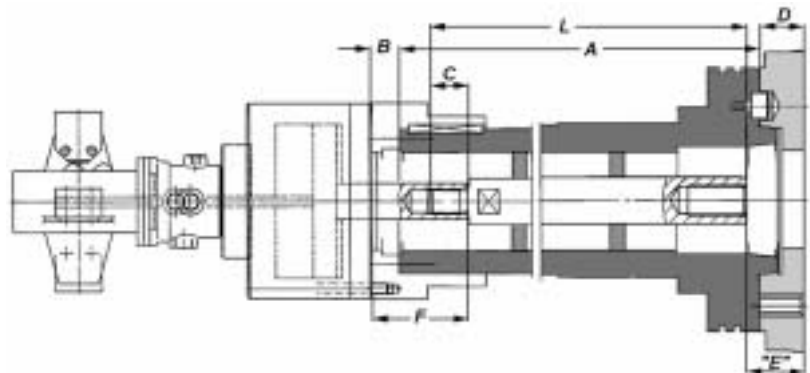
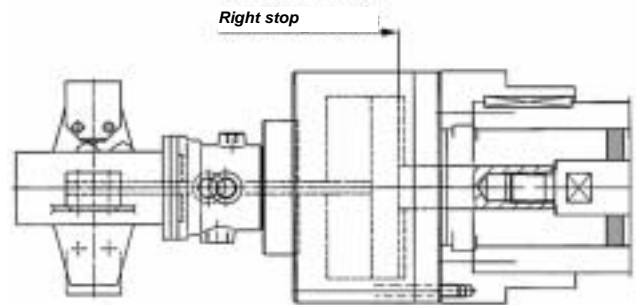

Connecting rod length $L = A + B + C + D - E - F$

AG 85

Chuck type 3 QLC - AG	➔	175	200	250	315	400
Adjustment dimension "E" +0.2 mm	➔					

7.3 Counterbalancing the rotating parts:

The high speeds require good counterbalancing of the rotating parts. As the rotating bodies spin, any imbalance will induce free centrifugal forces, which will cause oscillations and negatively affect the product quality. Since the centrifugal forces per unit of mass increase with the square of the speed, the requirements for accuracy in counterbalancing become ever greater as the parts speed increases.

For this reason, the lathe's spindle, the drawbar cylinder, the cylinder flange, the power chuck, the intermediate or chuck flange, and the connecting rod must be balanced.

The power chuck is dynamically counterbalanced, whereby the imbalance is counteracted by screwing balancing weights into the chuck body and the counterbalance quality $G = 2.5$ to 4.3 (depending on chuck size) is maintained in accordance with VDI 2060 (or DIN ISO 1940).

Chuck flanges and connecting rods that we deliver are also counterbalanced.

The drawbar cylinder must be counterbalanced at two levels, whereby imbalance is counteracted by screwing counterbalancing weights into the drawbar cylinder's lid or cylinder body and a counterbalance quality of $G = 2.5$ according to VDI 2060 (or DIN ISO 1940) is achieved.

7.4 Assembly of the power chuck:

Before assembling the power chuck, remove any chips that may be present in the machine spindle. Clean the centering receiver and bearing surfaces of the chuck flange!

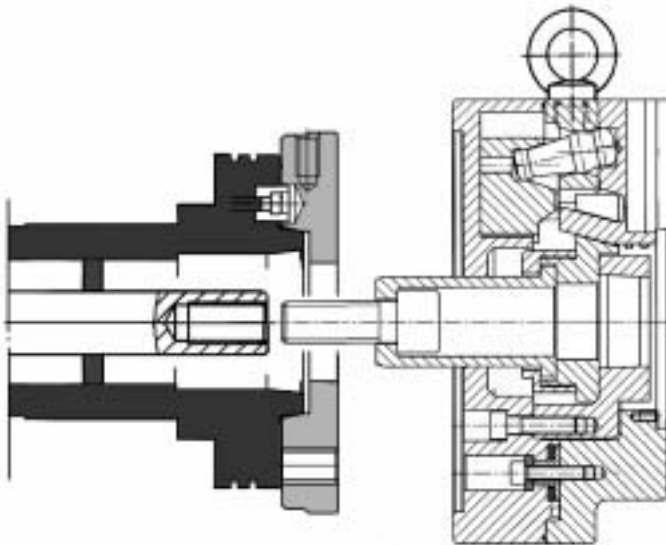

If using a ring bolt, screw it into the threaded hole located on the circumference of the chuck body. A lifting device with hooks can then attach to the ring bolt and bring the chuck body to the same height as the spindle head.

ATTENTION !

Attach to the power chuck only by means of the ring bolt screwed into the threaded hole (on circumference of chuck body)!

← See figure AG 86

AG 86

7.4.1 Procedure for assembling the power chuck:

ATTENTION !

If you are using a lifting device that can approach from any direction, note the following: The lifting device's carrying capacity must be appropriate for the weight of the power chuck! See section 1.4, page 5 for weights of the power chucks.

ATTENTION !

Use hooks and an attachment line (wire cable or strap) to attach the lifting device to the power chuck and bring the power chuck to the same height as the spindle head.

ATTENTION !

The attachment line (wire cable) or belt must comply with the technical delivery conditions of DIN 6890!

Loosen the machine screws (21) and remove the protective bushing (4) from the center bore of the chuck body. Slide the power chuck with its centering receiver onto the chuck flange's centering collar, making sure that the attachment bolts line up properly with the threaded holes on the chuck flange. Use a hexagon wrench (according to DIN 911) to screw the tensioning bolt (18) into the connecting rod's threads until the connecting rod contacts the tension sleeve (11). Screw the machine screws (19) that are placed in the chuck cap into the chuck flange's threads and use a torque wrench to tighten them snugly. While doing this, use a dial gauge to precisely center the power chuck!

ATTENTION !

Before using a torque wrench to fully tighten the fastening bolts in a clockwise direction, align the power chuck so that, the pointer on the gauging surfaces of the power chuck does not exceed a value of 0.01 mm when assembly is complete.

ATTENTION !

Make sure that the power chuck contacts on the entire surface!

After completing assembly of the entire power chuck clamping device, **always check for an imbalanced condition and remove any residual imbalance** by inserting the proper DIN 914 threaded pins in these locations:

- *on the cylinder side: into the cylinder flange's threads (see also image AG 81, page 41),*
- *on the power chuck side: insert the appropriate balancing weights into the chuck flange's balancing bores (see also image AG 86, page 43).*

Do not use the threads in the body of the drawbar cylinder or in the body of the power chuck for this purpose because this would destroy the precise dynamic balancing of the drawbar cylinder or power chuck!

Using the dial gauge on the gauging surfaces of the power chuck to check for proper mounting.

Truth of running: max. 0.01 mm (guideline)

Axial runout: max. 0.01 mm (guideline)

See figure AG 87 →

If the power chuck without top jaws is sluggish or tight, the chuck body may be distorted. Remove the power chuck from the machine spindle. Check the chuck receiver's end face for evenness!

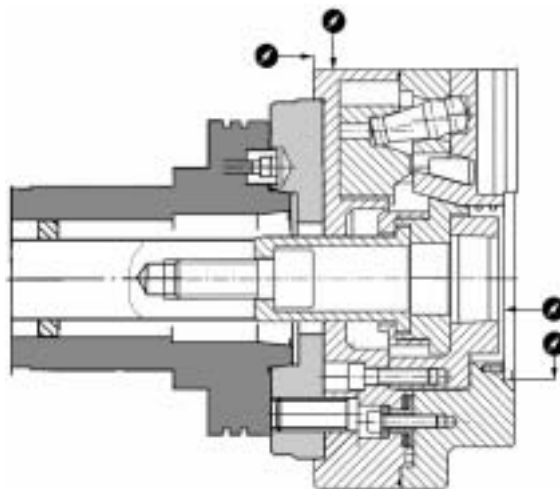

AG 87

Observe the proper tightening torque of the chuck attachment bolts. Refer to the following tables!

DIN 912 screws		Quality 10.9				Design according to DIN 267		
Threads		M 4	M 6	M 8	M 10	M 12	M 16	M 20
Tightening torque	Nm	4.4	15	36	72	125	290	560
Max. Screw load	N	5800	13200	24300	38700	56500	110000	171000

Quality 8.8	Complies with DIN 267	DIN 7984-compliant screws		DIN 912-compliant screws
Threads		M 5	M 6	M 4
Tightening torque	Nm	5	8,5	3,0
Max. screw load	N	4850	6700	3900

7.5 Assembly of the centering inserts:

Clean dust and dirt from the centering cone in the holder and center bore of the protective bushing!

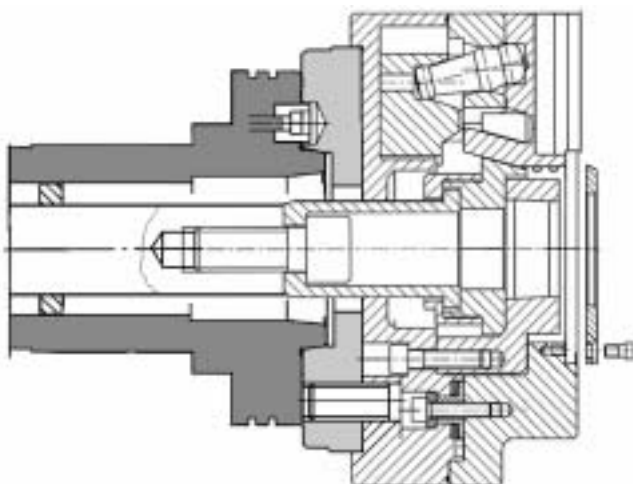

AG 88

After the power chuck has been aligned precisely, insert the protective bushing (4) into the center drills of the chuck body and use the three machine screws (21) to fasten it securely to the chuck body.

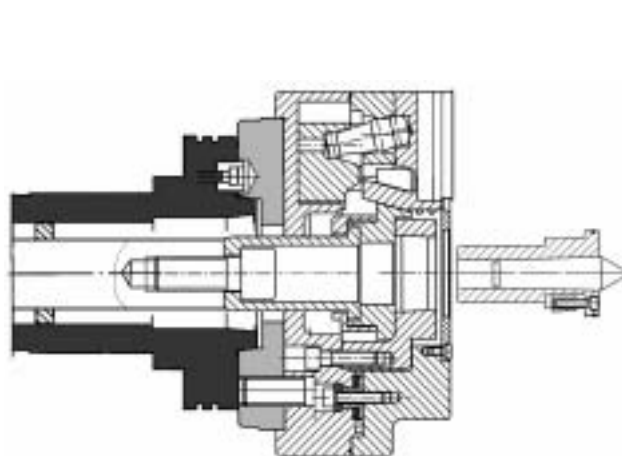

AG 89

Insert the type GS fixed centering tips with the three centering inserts through the holder recesses and turn them 60 degrees counterclockwise. Tighten the three machine screws evenly in order to precisely center the centering tips over the three centering inserts and simultaneously clamp them onto the cone. As this happens, the O-ring located in the centering tip will seal protective bushing.

7.6 Attaching the top jaws:

The top jaws are connected axially to the base jaws by means of sliding blocks and corresponding machine screws. Radial positioning is achieved by means of the pointed tothing on the base and top jaws. Please observe the following:

Never use damaged sliding blocks! The bearing surfaces of the sliding blocks must be in flawless condition.

When attaching the top jaws to the base jaws, refer to the labeling 1, 2, or 3 on the base jaws or associated guides in the chuck body! Attach top jaw 1 to base jaw 1 on the power chuck!

Do not damage the pointed teeth and screw the top jaws onto the base jaws only if the pointed teeth are in a flawless condition.

The teeth must be kept in good condition in order to ensure that the pointed teeth function properly and to avoid a loss of clamping precision.

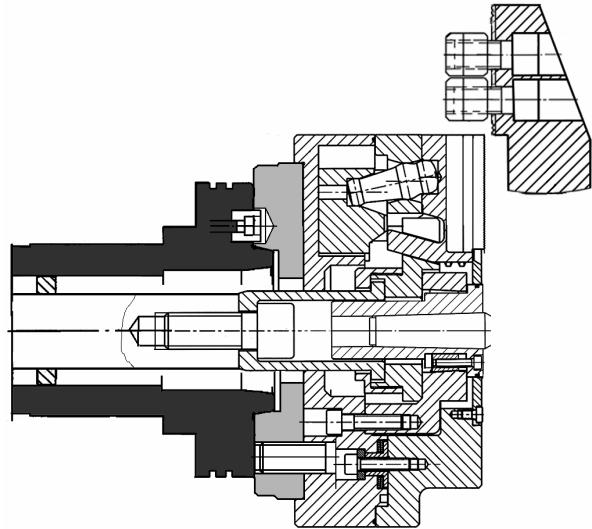

AG 90

You can use a truing plate and abrasive paste to quickly plane top jaws with pointed tothing. See section 5.15.6, page 30 for information on the truing plate. See brochure number 990.01.5D for additional information.

7.7 Adjusting the limit switches to the power chuck's working path:

To precisely adjust the limit switches to the power chuck's working stroke, apply hydraulic oil to connection 2, piston "K" with the drawbar cylinder's piston rod "k1" moves to the right until it contacts the drawbar cylinder. The screwed in connecting rod with tensioning bolt (18) and the tension sleeve (11) (inserted into the power chuck's (2) center bore and secured axially with the threaded bushing (12)) is actuated via the piston rod k1.

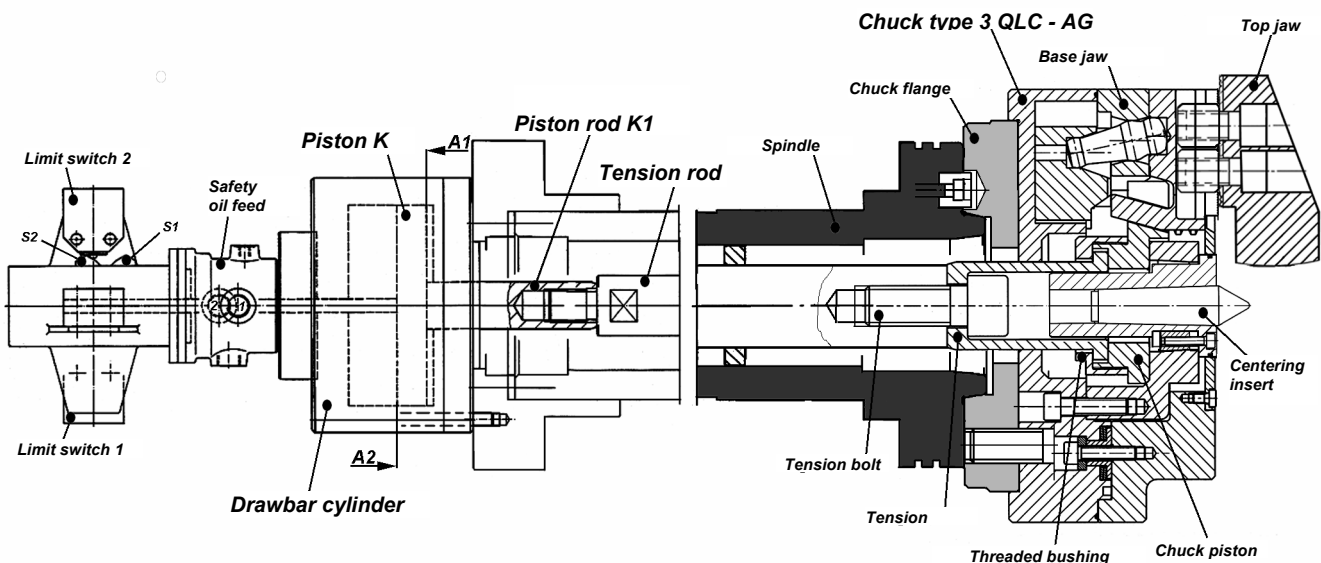

AG 91

The base jaws (3) with the screwed-on top jaws are moved outward, and thereby opened, via the chuck piston with wedge-hook mechanism. The "S2" trip cam is moved to the right or left until the limit switch "2" on the drawbar cylinder is actuated (impulse). This depressurizes cylinder chamber 1 (connection 1).

The work piece (with center bores on both ends) is fed with position orientation to the power chuck's centering tip and received between the centering tips of the power chuck and the tailstock. Engage the work piece on the power chuck by adjusting the tailstock's spring-loaded center tip.

Apply hydraulic oil to connection 1; piston **K** with piston rod **k1** of the drawbar cylinder type OKRJ, for example, moves to the left. The screwed-in tensioning bolt (18) and the tension sleeve (11) (inserted into the power chuck's (2) center bore and secured axially with the threaded bushing (12)) is actuated via the piston rod **k1** and the connecting rod. The base jaws (3) with the screwed-on top jaws are moved inward via the chuck piston with wedge-hook mechanism, thereby clamping the work piece in a compensating manner. The "S1" trip cam is moved to the right or left until the limit switch "1" on the drawbar cylinder is actuated (impulse). This depressurizes cylinder chamber 2 (connection 2).

ATTENTION! *When adjusting the limit switches (mechanical or contactless) to the power chuck's working stroke, always respect the stroke path reserve of 1 mm (for secure switching) in both directions!*

You may start the power chucking device only after actuation of the "1" limit switch and after the selected gripping pressure has been achieved.

Depressurize the drawbar cylinder after precisely adjusting the limit switches!

7.8  Safety notices:

The testing guidelines of the professional association specify, *in addition to pressure monitoring for the drawbar cylinder, a chucking stroke monitoring device* that ensures that the clamping device cannot be switched on at the end of the stroke and when the power chuck is open or is forced to stop, respectively.

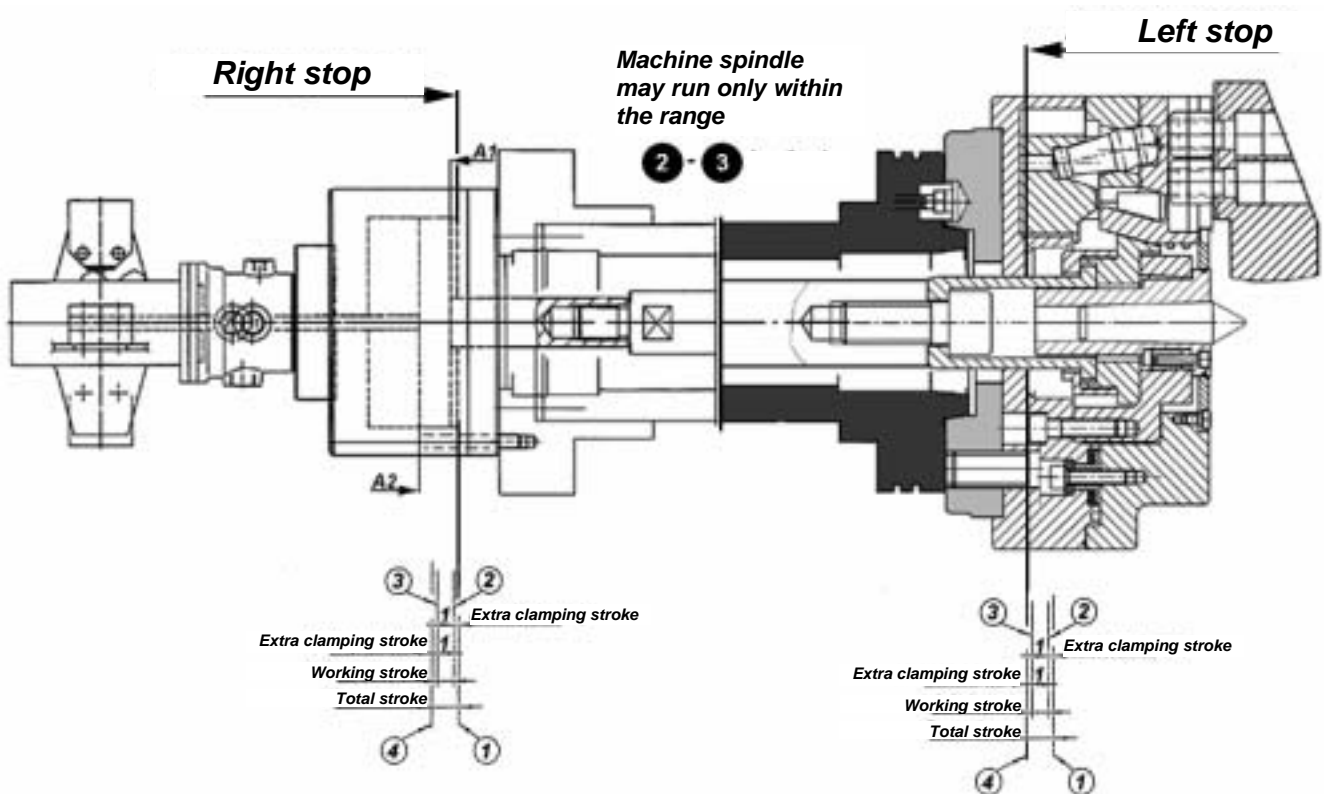

- * **Use safety limit switches according to VDE 0113 / 12 with mechanical, forcefully-activated, normally closed contacts for monitoring the chucking stroke. If other control devices like contactless limit switches are used in place of these safety limit switches, they must achieve the same level of safety.**
- * **Set the trip cams for actuating the safety limit switches on the drawbar cylinder to the power chuck's permissible working range so that there is a 1-mm stroke reserve (extra clamping stroke) in both directions! See section 1.4, page 5 for the piston stroke of the power chuck.**
- * **Check to make sure that the electric clamping path control on the drawbar cylinder is working flawlessly! The limit switches must switch reliably before reaching the two end positions!**



It should not be possible to switch on the clamping device when the power chuck is completely open or completely closed (in the end positions) because the safety limit switches will stop the clamping device.

- * **Test the entire control system. Check the associated instruments, like the pressure-monitoring valve with integrated pressure monitoring, for proper functionality!**
- * **Inspect the protective equipment and their locks to make sure they are in a safe condition! Protective devices are intended to stop or switch off the clamping device in the event of a power failure!**

7.9 Start-up preparations:

After assembling the entire power chuck and drawbar cylinder, observe the following before start-up in order to ensure proper functionality:

- * **Free the machine from any foreign objects, like assembly tools.**
- * **Lubricate the power chuck at the lube nipples (AM 8x1, DIN 71412) on the face side of the chuck body; five strokes from the grease gun are sufficient.**
- * **Carefully remove any excess grease from the jaw guides.**
- * **Inspect all visible screwed connections to make sure they are snug.**
- * **Inspect all drawbar cylinder tubes that carry hydraulic oil, leak oil, and other liquids to make sure they are installed and connected properly.**
- * **Inspect the selected operating pressure and working pressure on the hydraulic unit.**
- * **Close the protective doors, start the machine according to the machine program, and allow the machine spindle to run.**
- * **Check for any abnormal running noises.**
- * **Execute an empty stroke of the power chuck in order to distribute the grease and check the functionality of the power chucking device.**
- * **Execute a functional check according to the functional sequence. Check electrical switches, like stroke control via the limit switches, in addition to the clamping and releasing functions.**
- * **Stop the machine spindle, switch off the machine.**

8.1 Notices:

The initial start-up is a major factor in achieving optimal performance from the power chuck, whereby you will also determine whether there were any errors during assembly of the power chuck.

- Centrally install the top jaws and use the sliding blocks to establish the connection with the base jaws. Tighten the jaw attachment bolts according to the torque specified in section 5.11 on page 24.
- Observe the labeling 1, 2, 3 on the chuck body (guides) and the base jaws when installing the base jaws.

ATTENTION!

Insert base jaw 1 into guide 1 of the power chuck. Proceed in the same manner with base jaws 2 and 3.



Do not overload the power chuck! Adjust the pressure on the drawbar cylinder so that the permissible actuation force according to section 1.4, page 5 is not exceeded!

- The power chuck must open and close with 1/10 of the permissible actuation force!
- Sluggishness or tightness of the power chuck may be caused by distortion in the base or top jaws. Screw off the top jaws and inspect the pointed tothing and sliding blocks.
- If the power chuck without top jaws is sluggish or tight, the chuck body may be distorted. Check the end face of the chuck-receiver flange and the chuck cap for evenness!
- Inspect the jaw stroke and piston stroke! See section 1.4, page 5 for the jaw stroke and piston stroke.
- Measure gripping force F_{spo} with a static gripping force meter like the SKM 1200 / 1500 and compare this value with the value in the table in section 1.4, page 5!

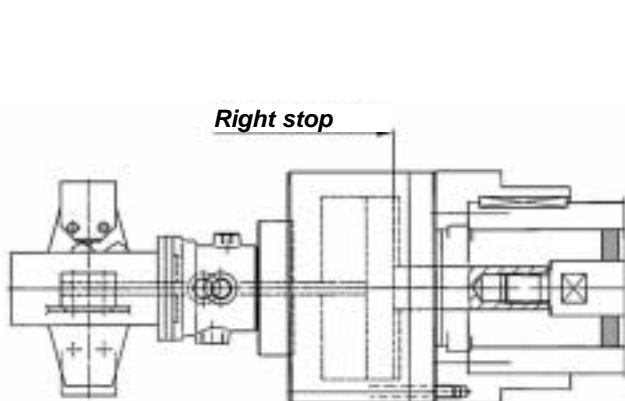

AG 93

Piston stop to the *right* - always in the drawbar cylinder, not in the power chuck.

Anschlag rechts: Right stop, Anschlag links: Left stop

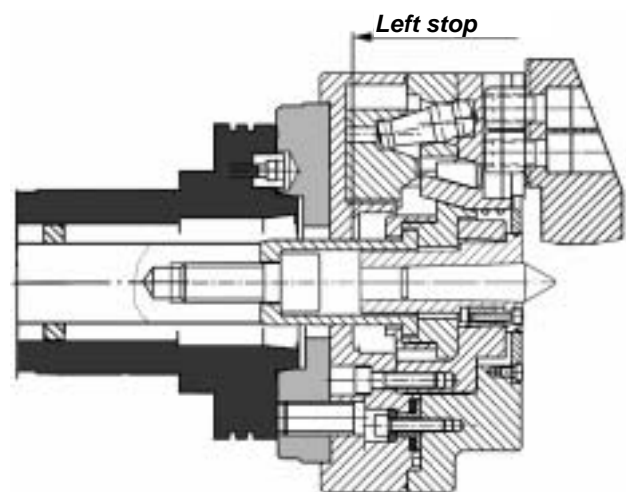

AG 94

Chuck piston stop to the *left* - always in the chuck body or in the chuck flange.

8.2 Start-up:

8.2.1 Notices:

Carefully observe the manufacturer's operating instructions when bringing the drawbar cylinder into operation! Drawbar cylinders normally do not require any particular running-in period. **However, whenever possible do not start them with cold oil (20 to 30 °C) and a high rotational speed!** If the hydraulic unit does not have external heating, allow the drawbar cylinder to warm up for about ten minutes at 1/3 normal speed so that the oil will heat up appropriately. This time may vary depending on the ambient temperature and the viscosity of the oil! **Operate the drawbar cylinder with maximum speed only after reaching the minimum oil temperature of 35 °C.**

Set the piston-stroke limit on the drawbar cylinder's stroke monitor! Set the piston stroke according to the power chuck's clamping stroke!

8.2.2 Start-up, operation:

Insert and clamp the work piece into the power chuck with position orientation. Start the machine and wait for clearance to switch on the machine spindle in accordance with the machine program.



The machine spindle may start only when the gripping pressure has been established (refer to pressure monitor) and the work piece has been clamped in the power chuck's permissible working range!



Work pieces may be machined at high speeds only under adequately dimensioned safety doors!

Close the safety doors, attach protective equipment!

ATTENTION!

The operator must inspect the gripping condition of the work piece and be confident that it is acceptable before starting the machining cycle. The machining cycle may be started only when the work piece has been clamped properly!

- **The safety doors must be locked while the machine spindle is running. Open the safety doors only after the machine spindle has stopped moving!**
- **Local safety regulations always apply to the operation of the power chuck! We refer here to the appropriate accident-prevention regulations of the respective professional association.**
- **Check for any abnormal running noises!**

The power chuck's accuracy will be apparent during repetitive clamping of a work piece and according to its truth of running when the work piece is machined in a series of chucking operations. If the center of the clamping cross-section deviates from the rotational center in excess of the specified tolerance, the result will be faulty work pieces and waste!

8.3 Selecting oil:

The drawbar cylinder can be operated with any hydraulic oil that has a viscosity of approximately 30 to 50 centistokes. For normal cases, we recommend a viscosity of 46 centistokes at 40 °C. This corresponds with the ISO recommendation VG 46 according to DIN 51519. Examples include:

ARAL TU 524 (VG 46)
 ARAL TU 508 (VG 32)
 SHELL TELLUS C 46 (VG 46)
 SHELL TELLUS C 32 (VG 32)

Oils from other major brands that meet the above qualifications may also be used.

ATTENTION!

The use of oil type VG 32 may result in large leaks in the drawbar cylinder.

Recommended oil	Operational temperature	ARAL		BP		Esso		Mobil		Shell	
			Viscosity in cSt at 50 °C		Viscosity in cSt at 50 °C		Viscosity in cSt at 50 °C		Viscosity in cSt at 50 °C		Viscosity in cSt at 50 °C
25 -54 cSt under working conditions	Heat 60 – 80°C	Aral oil GFY	49.0	Energol HLP 150	49	Esstic 55	49	Mobil D.T.E.Oil Heavy	51	Shell Tellus 137	49.0
		Aral oil TU 524	49.0	Energol HLP 175	65	Teresso56	49	Mobil D.T.E. 26	37	Shell Tellus 537	49.0
		Aral oil TU 528	68.0			Hydraulic oil 49EP	49			Shell Tellus 33	approx. 38
						Nuto H 64	62			Shell Tellus 41	60
										Shell Tellus 141	60

Grease the power chuck through the AM8x1 funnel-type lubricating nipples (DIN 71412) on the face side of the chuck body with the special **FORKARDT PF 6 grease**.

8.6 Impermissible operating methods:

ATTENTION!

Immediately remove any system imbalance that may appear on the hydraulic drawbar cylinder or on the power chuck.

ATTENTION!

Do not leave the work piece in the power chuck overnight because the work piece may fall out after the clamping energy (hydraulic oil) has been switched off!

8.7



Safety notices:

- * *The machine spindle may start running only when the hydraulic unit's clamping pressure has been built up and the work piece has been clamped in the power chuck's permissible working range.*
- * *When the power chuck is rotating, the operational gripping force must be measured with a dynamic gripping force meter like the FORSAVE D. See also section 6.3.*
- * *Calculate the dynamic loss of gripping force for every configuration process and make sure that the gripping force is sufficient for the machining task. See also section 6.2.*
- * *If a loss of clamping energy is detected, the machining process must be terminated immediately and the machine spindle stopped.*

* *When producing larger series, intermediate empty chucking (clamping without a work piece) is always necessary in order to retain clamping pressure. Uniform clamping pressure on the power chuck is ensured only when the lubrication is preserved because the grease will distribute itself to the parts that are under load.*

* *Release the work piece only when the machine spindle has stopped!*

8.8 Handling disturbances:



Regardless of the following notices, local safety regulations always apply to the operation of the power chuck!

We recommend a lockable local switch that will prevent the machine spindle from being switched on unintentionally during repairs or disturbances. The following table lists the symptoms, causes, and countermeasures associated with disturbances on the power chuck. We cannot guarantee completeness of this information due to certain factors, such as the operating personnel's level of knowledge.

Symptom	Cause	Countermeasure
The machine is vibrating strongly	Improper assembly has led to imbalance of the chuck flange or the cylinder flange and possibly the power chuck or the drawbar cylinder.	Check the truth of running on the gauging surfaces of the power chuck. Immediately remove system imbalance on the power chuck or on the drawbar cylinder. Possibly rebalance the chuck flange or the cylinder flange. Readjust the spindle housing.
Clamping force is too low	Contamination. Insufficient lubrication.	Clean the power chuck. Check lubrication. If insufficient: disassemble, clean, and lubricate the power chuck.
Jaw stroke is not achieved	Base jaw is improperly assembled or is inverted. Incorrect connecting rod length.	Check and replace if necessary. Check adjustment dimension "E".
No clamping force	Distortion in the base jaws.	Check the bearing surfaces. Contract manufacturing if necessary.
Top jaw cannot be moved.	Toothing on the base jaw or the top jaw is dirty.	Clean. Self-made top jaws may exhibit varying division.
Truth-of-running errors on internally ground, soft top jaws are too large (during centric clamping).	Base jaws inverted, possibly also the top jaws.	Check and replace if necessary.

8.9 Restarting after a disturbance:

See sections 8.1 and 8.2.

8.10 Steps to take during longer idle times:

- *Remove the clamping-cylinder piston to the right!*
- *Remove the work piece from the power chuck!*
- *Clean and degrease the power chuck!*



***Do not use compressed air to blow out the power chuck because this may cause chips and coolant to get into your eyes!
Danger of injury!***

8.11 Steps to take after longer idle times:

- ***Clean preservative from the parts.***
- ***Attach the tubes for hydraulic oil, leak oil, and other liquids onto the drawbar cylinder!***
- ***Adjust the operational and working pressure on the hydraulic unit!***
- ***Lubricate the power chuck. Remove any grease that has emerged!***
- ***Execute an empty stroke in order to distribute the grease!***
- ***Use a gripping-force measuring device (like the SKM 1200 / 1500) to measure the gripping force F_{spo} while the machine spindle is stopped!***
- ***Insert the work piece into the power chuck and chuck it with compensation (or concentrically).***
- ***Then proceed in the manner described under sections 7.4 and 8.2.***

9.1 Maintenance:

9.1.1 Notices:

Always observe section 2 "**Safety Notices**" when performing maintenance and service work.

- **The operational safety and lifespan of the power chuck will depend on proper maintenance, in addition to other factors.**

Due to the varying operational conditions, it is not possible to say in advance how often it will be necessary to maintain the power chuck, check for wear, or perform repairs. This must be determined individually in view of the severity of use and the amount of contamination.

Operational hours/periods	Inspection point/maintenance notices
After 24 hours; during the initial start-up or repair.	Lubricate the power chuck. Check the screw connections for snugness. Check the hydraulic oil seals on the drawbar cylinder for leaks.
Weekly	Lubricate the base jaws and the chuck piston over the cone lube nipple located on the face side of the chuck body.
Weekly	Use a gripping force meter like the SKM 1200 / 1500 to check F _{spo} .
Weekly	Check for proper functionality of the power chuck and the hydraulic drawbar cylinder.
Monthly	Check the chuck piston's wedge hooks and the base jaws for wear. Check the hydraulic oil seals on the drawbar cylinder for wear.

9.1.2 Repair, maintenance:



**Before starting maintenance, inspection, or other tasks on the machine, always stop the machine spindle and secure the lathe against restarting with a lockable local switch!
Remove the piston of the drawbar cylinder to the right!**



**Depressurize any hydraulic lines for the drawbar cylinder that are under pressure!
Place a warning sign at an appropriate place!**

ATTENTION!

Check the maintenance status with a static gripping force meter like the SKM 1200 / 1500!

If the gripping force F_{spo} at stop (specified in section 1.4, page 5) is no longer achieved even after good lubrication, then the power chuck must be removed from the machine spindle, dismantled into its individual parts, cleaned, and regreased!

- * **Move the piston of the drawbar cylinder to the right!**
- * **Depressurize the hydraulic unit!**
- * **Direct the oil from the drawbar cylinder back into the oil container.**
- * **Remove the tubes for hydraulic oil, leak oil, and other liquids from the drawbar cylinder!**

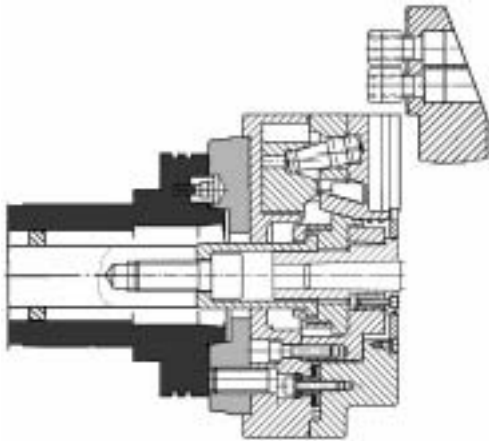
9.2 Disassembling the power chuck:

AG 95
Remove the jaw attachment bolts (24) from the base jaws by turning them three revolutions with a hexagon wrench. Then remove the top jaws with the sliding blocks from the base-jaw guides.

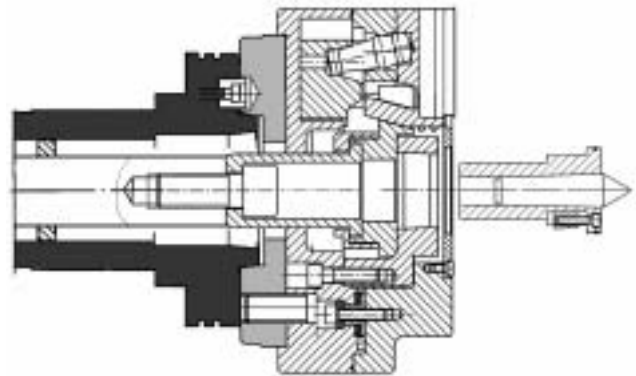

AG 96
Loosen the machine screws from the centering inserts on the centering tip until the clamping effect between the cone of the centering inserts and the holder has been released. As this happens, the centering insert with O-ring will move out of the protective bushing. Lightly tap the centering insert with a rubber mallet to loosen it and then remove it from the holder by rotating it clockwise by 60°.

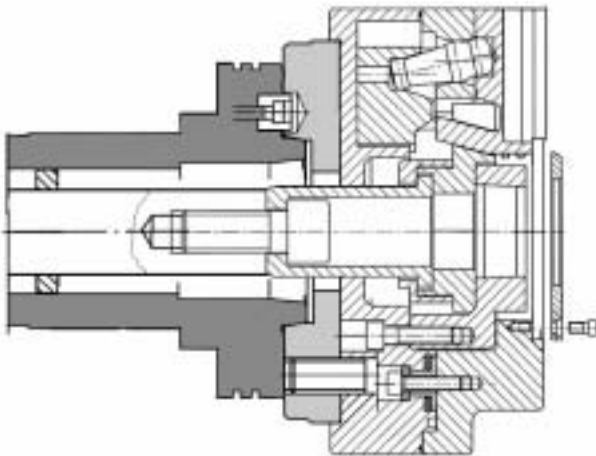

AG 97
Screw out the machine screws (21) from the chuck body and use the push-off threads to pull out the protective bushing (4) from the chuck body by means of the corresponding machine screw.

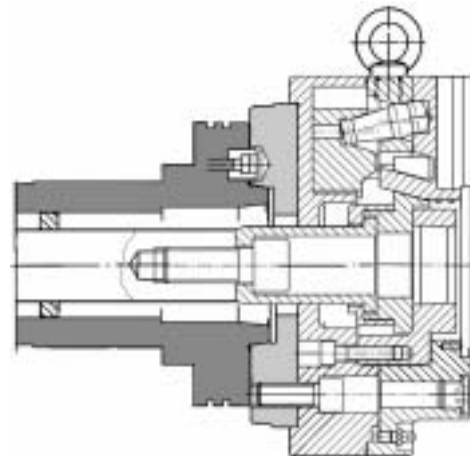

AG 98
Screw a ring bolt into a threaded bore located on the outside diameter of the chuck body. You can now attach the lifting device by means of a hook and attachment line (wire cable or belt).

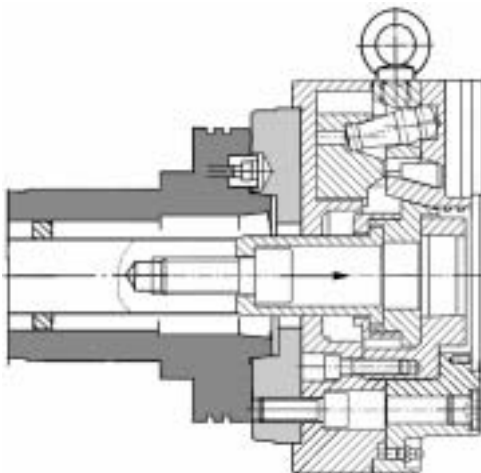

AG 99
Screw out the tensioning bolt (18) from the connecting rod threads.

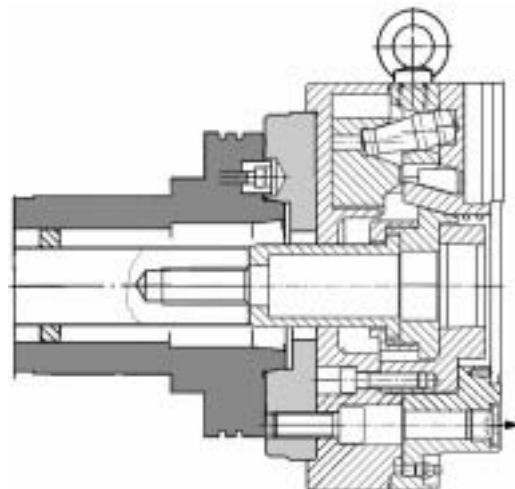

AG 100
Screw out the locking screws (15) from the chuck body and loosen the chuck attachment bolts (19).

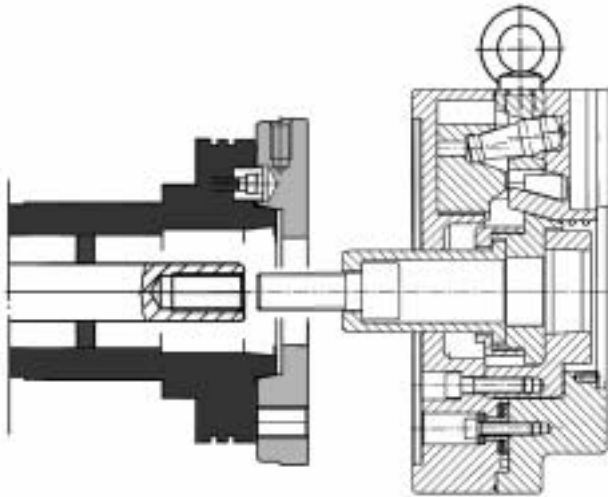

AG 101

Pull the power chuck from the centering collar of the chuck flange and place the power chuck on a pallet or workbench.

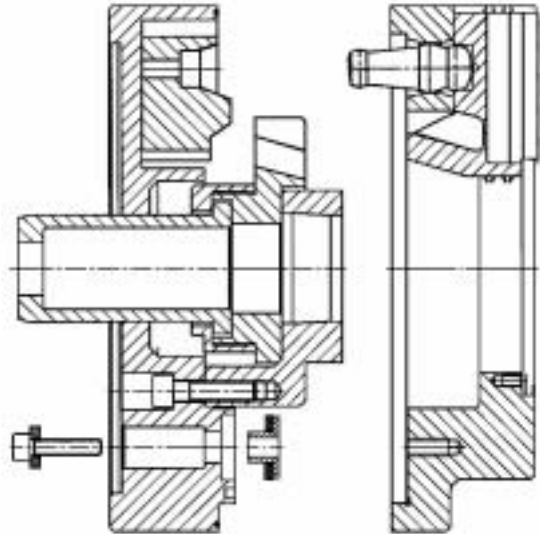

AG 102

Screw out the machine screws (20) from the chuck body, taking care not to lose the washers (14). Turn the appropriate machine screw to employ the push-off threads to remove the chuck cap (5) together with the tension sleeve (11), chuck piston (2), and holder (6) from the center bore of the chuck body. Carefully remove the chuck cap (with the centrifugal weights (9)) from the levers (10). Take care not to lose the O-ring (22).

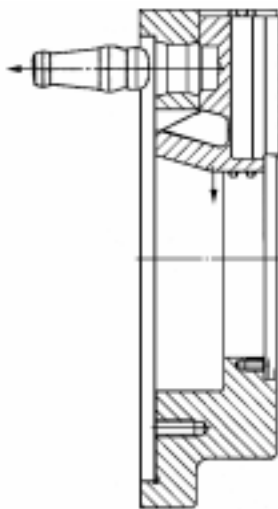

AG 103

Remove the levers (10) from the center bores of the chuck body and the base jaws (3). Slide the base jaws one at a time towards the center of the chuck and remove them from the chuck body guides.

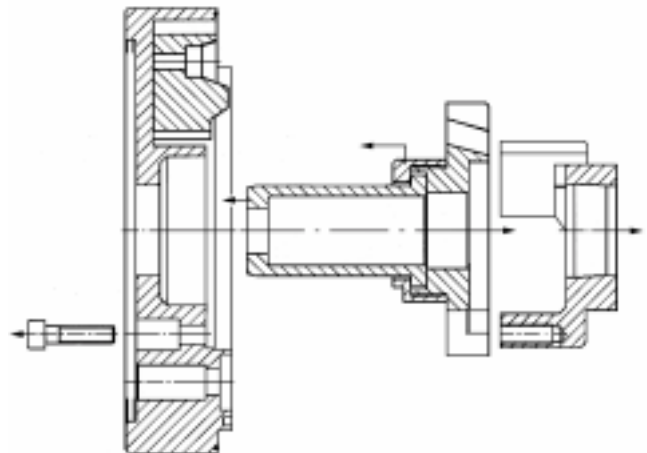

AG 104

Screw the machine screws (7) from the holder and pull the holder from the chuck lid. Pull the chuck piston with tension sleeve from the center bore of the chuck cap. Screw the threaded bushing (12) from the external threads of the chuck piston (2) and remove from the tension sleeve (11). Check the wedge hooks of the chuck piston and the base jaws for damage.

- **Check all parts for damage, wash them out, and clean them. Replace any defective parts. Use grease like PF 5 or PF 6 to grease the chuck piston, base jaws, chuck body (on the chuck-piston and base-jaw guides and on the wedge hooks), centrifugal weights, levers, and guides in the chuck cap (for the centrifugal weights)!**
- **Check the O-rings for damage and wear; replace defective parts, lubricate them with grease, and carefully reinsert them into the respective individual parts.**
- **If it is necessary to replace attachment bolts, always use bolts of the same dimensions and quality!**
- **Follow the reverse sequence to reinstall the individual parts into the chuck body.**

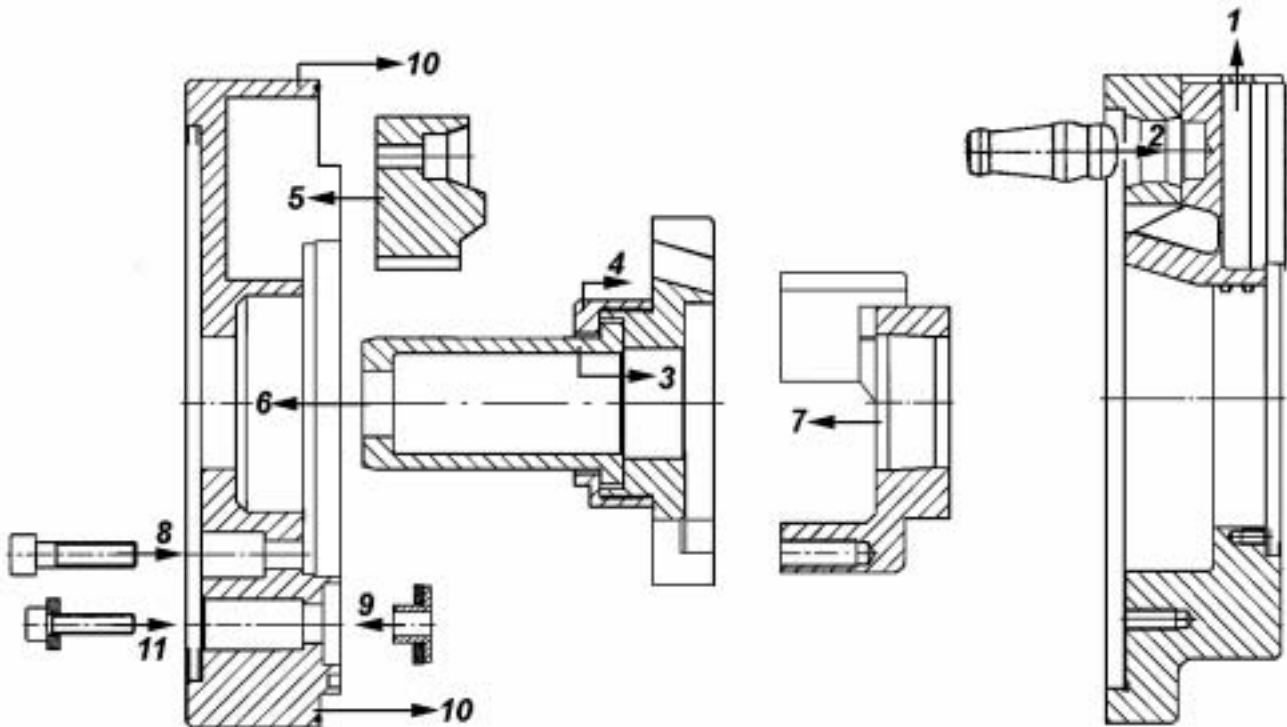

AG 105

ATTENTION!

Observe the numbering when installing the base jaws! Insert base jaw 1 into guide 1 of the chuck body, etc.

ATTENTION!

Insert chuck piston with wedge hook guide 1 into base jaw 1, etc.!

- * Attach the tubes for hydraulic oil, leak oil, and other liquids onto the drawbar cylinder!
- * Adjust and check the operational and working pressure on the hydraulic unit!
- * Move the drawbar cylinder's piston to the right until it contacts the cylinder body.
- * Assemble the power chuck onto the machine spindle as described under section 7.4, page 42.
- * Tighten the attachment bolts to the torque ratings specified in section 1.7, page 6 and section 5.11, page 24, respectively.
- * Start-up as described under sections 7.9 and 8.2.
- * Observe all safety notices!

9.4

Safety notices:

- * Occasional collisions between the tool and the power chuck, like those caused by disturbances in the program sequence, can damage the power chuck.
- * If a collision occurs, immediately stop the lathe and check the power chuck for damages. Do not continue to work with the power chuck. Instead, immediately remove it from the machine spindle!
- * In addition to damages that are easy to detect (like on the top jaws and attachment bolts), there may also be hidden damage like hairline fractures in the chuck body and in the base jaws.
- * In order to preclude any potential danger in these cases, the affected power chuck parts should be checked for fractures in a suitable, non-destructive test. If damages are found, replace the damaged parts!

Suitable testing processes are:

- the color penetration process
- fluxing

* **If it is necessary to replace top-jaw attachment bolts, always use bolts of the same dimensions and quality!**

9.4 Lubrication:

Foreign material penetrates into virtually every power chuck. Cinders and casting dust increase friction in the moving parts; chips impede movement; coolant washes out lubricant. The power chucks type 3 QLC - AG are sealed against functional disturbances caused by the penetration of coolant, dirt, and chips. A toroidal ring hermetically seals the gap between the chuck body and the chuck cap. All movement gaps exhibit close fits and hardened guard plates. The protective bushing is sealed by an O-ring located in the centering tip.

Nevertheless, the power chuck should be regularly cleaned and lubricated because this will help ensure uniform gripping force, accuracy, and a long service life.

ATTENTION !

Careful lubrication is essential for disturbance-free operation.



Perform lubrication and all tasks associated with lubrication only when the machine spindle is stopped!

ATTENTION !

Dirty or poorly lubricated power chucks will lose a significant amount of their gripping force!



The power chuck must be relubricated when the gripping force F_{spo} while the spindle is stopped no longer reaches the value specified in the table in section 1.4, page 5.

ATTENTION !

Use a static gripping-force measuring device (like the SKM 1200 / 1500) to regularly check the gripping force when stopped.

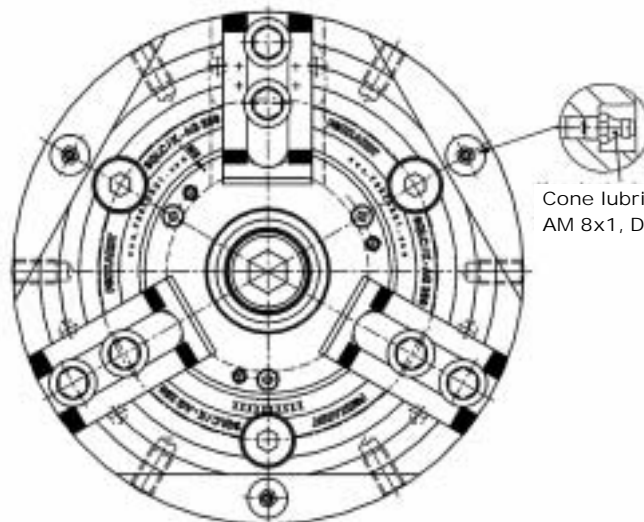

Cone lubrication nipple
AM 8x1, DIN 71412

- Lubricate the power chuck. Five strokes with the grease gun are sufficient. See brochure 990.01.5D for the grease gun.
- We recommend the following grease types:
 - PF 5 for all other power chuck parts
 - PF 6 for the wedge hooks on the drive jaws and the chuck piston and for the piston guide.
- Store lubricants only in clean, sealed containers. Store in a cool, dry place!

9.5 Service:

9.5.1 Notices:

We recommend requesting the presence of the manufacturer's personnel for the initial repairs. This will give your service personnel an opportunity for intensive learning.

If you will perform repairs yourself, refer to the replacement parts list in section 10.2, pages 59 to 61 to order replacement parts.



Before starting any repairs on the power chuck, always stop the lathe and secure it against unintentional restarting.



Remove the top jaws from the base jaws!

Move the cylinder piston to the right!



Depressurize any hydraulic lines for the drawbar cylinder that are under pressure!

Place a warning sign at an appropriate place!

- This describes only repair tasks that are required during maintenance or those that are needed to replace wearing parts.
- If you will replace parts yourself, you should keep stocks of replacement and wearing parts.
- If screws become unusable when parts are removed, replace the screws with the same quality and type! Refer to the following tables.

9.5.2 Replacing parts:

As described under section 9.2.

Assembly as described under section 7.4.

Start-up as described under sections 7.9 and 8.2.

Observe all safety notices!

10.1 Replacement parts:

Keeping a good, on-site stock of the most important replacement and wearing parts is an important precondition for keeping the power chuck ready for operation and in continuous service. Please refer to the replacement parts list when ordering replacement parts.

For reasons of safety – use only ORIGINAL FORKARDT replacement parts!

The use of third-party parts on our products releases us from product liability obligations to the extent that damages are caused directly or indirectly by the use of these third party parts.

We warranty only ORIGINAL replacement parts that we delivered!

Please note that there are often special production and delivery specifications for our own parts and third party parts and that we will always deliver to you replacement parts made to the latest technical standards.

10.2 Lists of replacement parts:

10.2.1 Replacement parts list for power chuck type 3 QLC – AG:

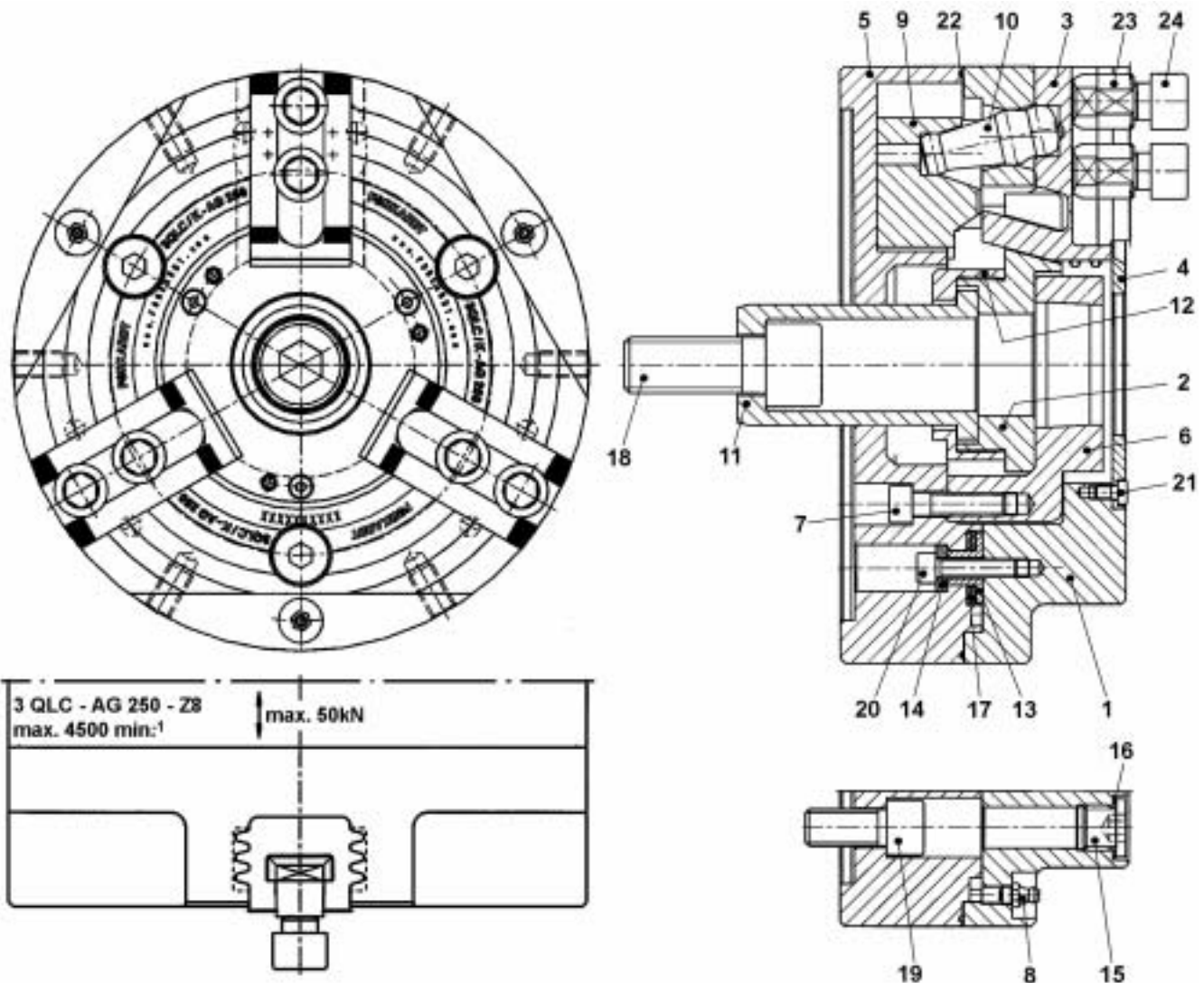

Number	Name	Power chuck type 3 QLC – AG					
		Part No.	175	200	250	315	400
ID No.					169747		
1	Chuck body	1			169747001		
1	Chuck piston	2			169747002		
3	Base jaw	3			165568003		
1	Protective bushing	4			169747004		
1	Chuck cap	5			169747005		
1	Holder	6			169747006		
6	Machine screw DIN 912 10.9	7			M10 x 40		
3	Cone lube nipple DIN 71412	8			AM8 x 1		
3	Centrifugal weight	9			169747009		
3	Lever	10			15684010		
1	Tension sleeve	11			169747011		
1	Threaded bushing	12			169747012		
6	Spring sleeve	13			169747013		
6	Washer	14			169747014		
3	Locking screw DIN 908	15			M20 x 1.5		
1	Sealing ring DIN 7603 Cu	16			21x26x1.5		
12	Plate spring DIN 2093 – A31.5	17			31.5x16.3x1.75		
1	Machine screw DIN 912 10.9	18			M24 x 60		
3	Machine screw DIN 912 10.9	19			M16 x 35		
6	Machine screw DIN 912 10.9	20			M8 x 35		
3	Machine screw DIN 7984 10.9	21			M6 x 10		
1	O-ring DIN 3771	22			240 x 2		
6	Sliding block	23			FN 232		
6	Machine screw DIN 912 10.9	24			M16 x 35		

10.2.2 Replacement Parts List for Centering Insert Type GS:

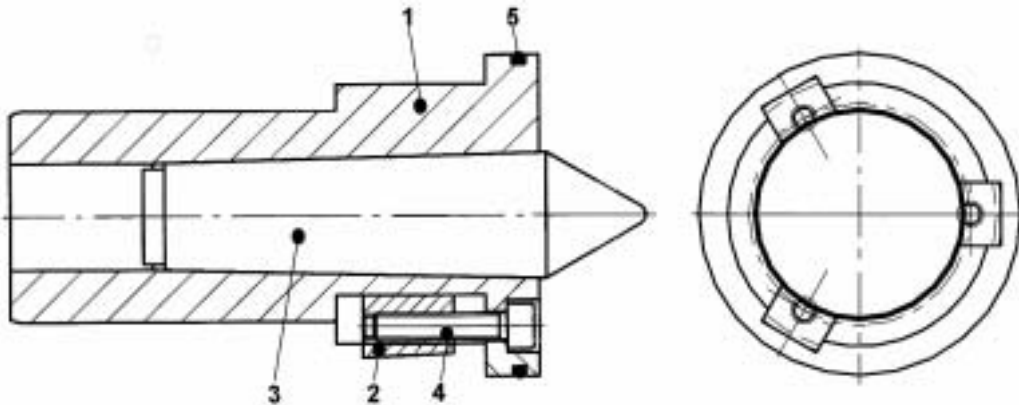

AG 108

Number	Name	Centering insert type GS					
		Part No.	QLC – GS 175	QLC – GS 200	QLC – GS 250	QLC – GS 315	QLC – GS 400
ID No.					169867		
1	Body of centering insert	1			169867001		
3	Centering insert	2			169867002		
1	Centering tip MK 3	3			420033042		
3	Machine screw DIN 912 10.9	4			M5 x 25		
1	O-ring DIN 3771	5			57 x 2		

10.2.3 Replacement parts list for centering insert type GF:

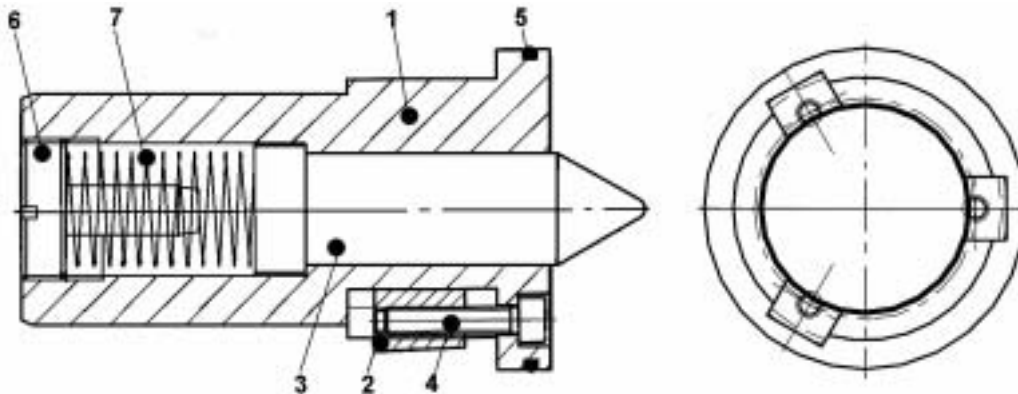

AG 109

Number	Name	Centering insert type GF				
		Part No.				
ID No.		♥				
1	Body of centering insert	1				
3	Centering insert	2				
	Centering tip	3				
	Machine screw DIN 912 10.9	4				
	O-ring DIN 3771	5				
		6				
		7				

10.2.4 Replacement parts list for centering insert type GZ:

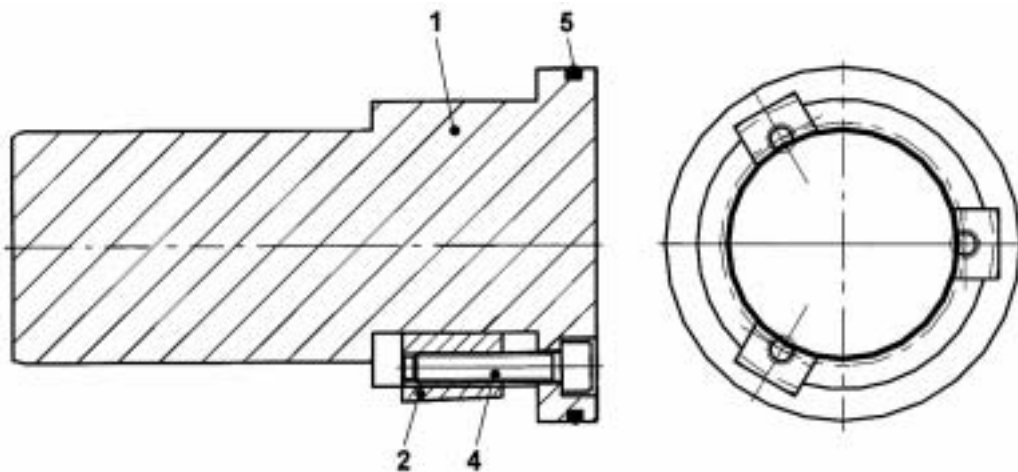

AG 110

Number	Name	Centering insert type GZ				
		Part No.				
ID No.		♥				
1	Body of centering insert	1				
3	Centering insert	2				
		3				
	Machine screw DIN 912 10.9	4				
	O-ring DIN 3771	5				

The following information must be provided when ordering replacement parts:

- Quantity
- Name
- Replacement parts list number
- Identification number
- Item
- Production number

The items labeled with ● are essential for ordering!

10.3 Address for Replacement Parts and Customer Service

FORKARDT

2155 Traversefield Dr

Traverse City, MI 49686

Telephone: 800-544-3823

Email: sales@forkardt.us

Website: www.forkardt.com

11.1 Tools and accessories:

The customer must provide the following:

Grease type PF 5 and PF 6, grease gun, see table!

You must provide degreasing agents, preservatives, etc. or you can order these things from us and they will be delivered with the product.

Ring bolt according to DIN 580



Chuck type 3 QLC – AG →	175	200	250	315	400
Threads G					

Designation	Type	ID No.	Packaging contents
Special grease	PF 5	101400 / 084	1.0 kg
Special grease	PF 6	101400 / 088	1.0 kg
Hand-operated grease gun	HH 1	101400 / 121	

11.2 List of associated brochures:

Accessories for Manual and Power Chucks		990.01.5D
Gripping force meter	SKM 1200 / 1500	300224.10.01D
Gripping force meter	FORSAVE D	620.01.6D

MANUFACTURER'S DECLARATION

Under the terms of the EC machinery directive 89 / 392 / EWC, exhibit II B and its current change directives (note date of issuance)

We hereby declare that this delivery includes the machine part designated below, which is intended for installation in a machine. Start-up is prohibited until it has been determined that the machine in which the machine part was installed complies with the stipulations of the EC directive.

Type designation: Power-operated triple-jaw compensating chuck

Type: 3 QLC - AG

Applied harmonizing standards, for each product: DIN EN 292 - 1, DIN EN 292 - 2, DIN EN 414, DIN EN 418, DIN EN 457, DIN EN 60 204 - 1

Applied national standards and technical specifications depending on usage: Testing principle GS - EM No. I / 2 - 50 of BG iron and metal II

Date / Manufacturer's Signature: 11/2004



(Director of Engineering,
Mr. Hildebrandt)

This declaration will lose its validity if parts of the product are altered or disassembled without our explicit approval!

Manufacturer's declaration No.: 3 QLC - AG

Forkardt Service Department



Paid Repair

The Forkardt service department assesses and repairs all brands currently produced by Forkardt. Customers can send their workholding to the Forkardt plant to receive an assessment for the repairs needed to bring it within original working condition. Any new improvements or revisions to that model will be incorporated into the repair, as if you are receiving a new chuck at a discounted price.

Most estimates are sent within one week of the item arriving at the Forkardt facility. A non-refundable assessment fee may be charged if there are extra ordinary efforts required.

Paid Service

Forkardt service technicians can help install or troubleshoot existing workholding set ups. This allows the customer to be trained and also allows the customer to reallocate resources by letting the experts take care of the product.

Technicians can perform on site training for preventative maintenance, disassembly and repair. This leads to improved and safer performance of the product.

Service technicians can also perform balancing on most brands of chucks in the field. This leads to improved performance of the machine, tooling and product.

Limited Warranty

Forkardt's products are warranted for a period of (1) year from date of delivery to be free from defects in material and workmanship.

This warranty does not include, nor does Forkardt assume responsibility for, defects or damage caused by misuse or abuse, alterations, service or repair by others, wear parts or failure to properly maintain the product.

OEM Serviceable Chucks

- NA Woodworth
- Forkardt
- SP
- Sheffer
- Logansport
- Buck Chuck
- Tork-Lok
- Teikoku

Contacts

- Service Department
(231-995-8348 jhalligan@forkardt.us)
- Inside Sales
(231-995-8348 sales@forkardt.us)

Ship To Address

2155 Traversefield Dr
Traverse City, MI 49686





OUR HISTORY

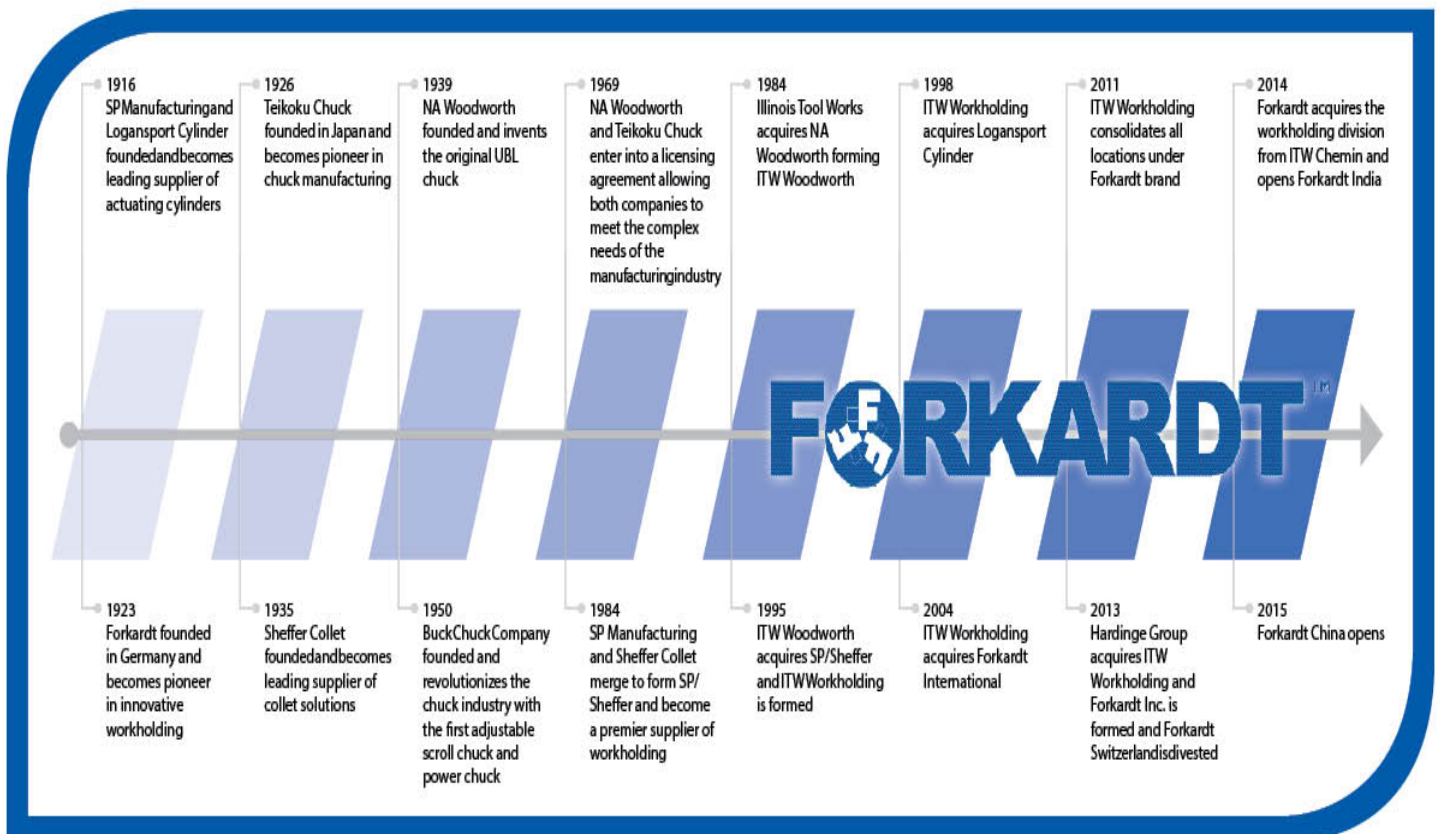

Innovative Technology by **FORKARDT**

L O C A T I O N S W O R L D W I D E

FORKARDT GMBH
Lachenhauweg 12
72766 Reutlingen-Mittelstadt
D-40699 Erkrath
Phone: (+49) 211 25 06-0
E-Mail: info@forkardt.com

FORKARDT USA
2155 Traversefield Drive Traverse
City, MI 49686, USA
Phone: (+1) 800 544-3823
(+1) 231 995-8300
Fax: (+1) 231 995-8361
E-Mail: sales@forkardt.us
Website: www.forkardt.com

FORKARDT FRANCE S.A.R.L.
28 Avenue de Bobigny
F-93135 Noisy le Sec Cédex
Phone: (+33) 1 4183 1240
Fax: (+33) 1 4840 4759
E-Mail: forkardt.france@forkardt.com

FORKARDT CHINA
Precision Machinery (Shanghai) Co Ltd
1F, #45 Building, No. 209 Taigu Road,
Waigaoqiao FTZ CHINA 200131,
CHINA
Phone: (+86) 21 5868 3677
E-Mail: info@forkardt.cn.com
Website: www.forkardt.com

FORKARDT INDIA LLP
Plot No. 39 D.No.5-5-35
Ayyanna Ind. Park
IE Prasanthnagar, Kukatpally
Hyderabad - 500 072
India
Phone: (+91) 40 400 20571
Fax: (+91) 40 400 20576
E-Mail: info@forkardtindia.com

www.forkardt.com