

# Largo

## Air Compressors

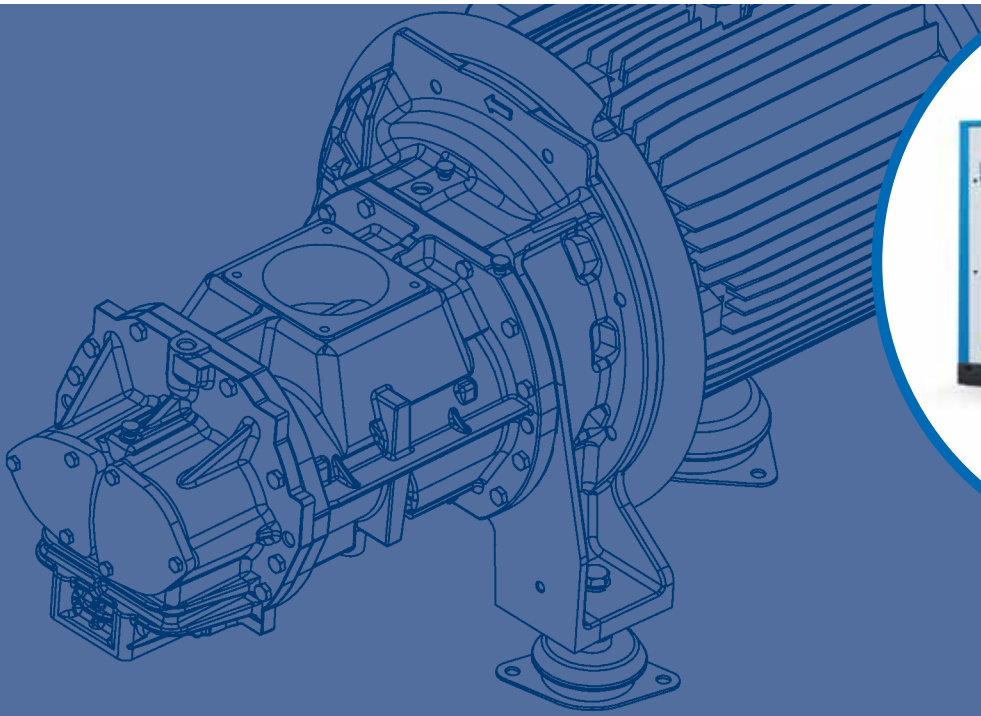

LARGO 200-250

**ALUP**  
Kompressoren



## ALUP

Driven by technology. Designed by experience.

*ALUP Kompressoren has over 85 years of industrial experience. It is our ambition to offer compressed air solutions that ensure we are first in choice for our customers. To reach this goal we need continuous investment in our product development to make sure that we are always able to offer:*

- High performance and excellent quality
- Integrated engineered solutions
- Full energy efficiency
- Total cost of ownership
- Environmental care

[www.alup.com](http://www.alup.com)



## Largo 200-250: A new milestone for ALUP Kompressoren

*Our objective at ALUP Kompressoren is always to offer the right solution to help our customers reach the highest productivity. Innovation, experience and continuous improvement have led us to reach the optimum levels of efficiency and reliability in the industry.*

*The new Largo 200-250 is the new milestone in this success story. Precise mechanics, modern design and high-quality components have been selected for these machines because there is no compromise when it comes to reliability.*

*The integrated and efficient package of the Largo 200-250 is designed to guarantee your peace of mind:*

- All components are meticulously selected.
- All machines are manufactured and tested according to ISO 9001, ISO 14001 and ISO 1217.

## A range to cover all your needs

### The Largo 200-250 sets a new standard in the industry

Several models and variants are available to meet your specific needs:

- Air or water variants
- Several pressure variants
- Numerous options to optimize your installation according to your needs

### Large range of options to enhance your system

- Energy efficiency
- Lubricants and servicing
- Monitoring and connectivity
- Power protection

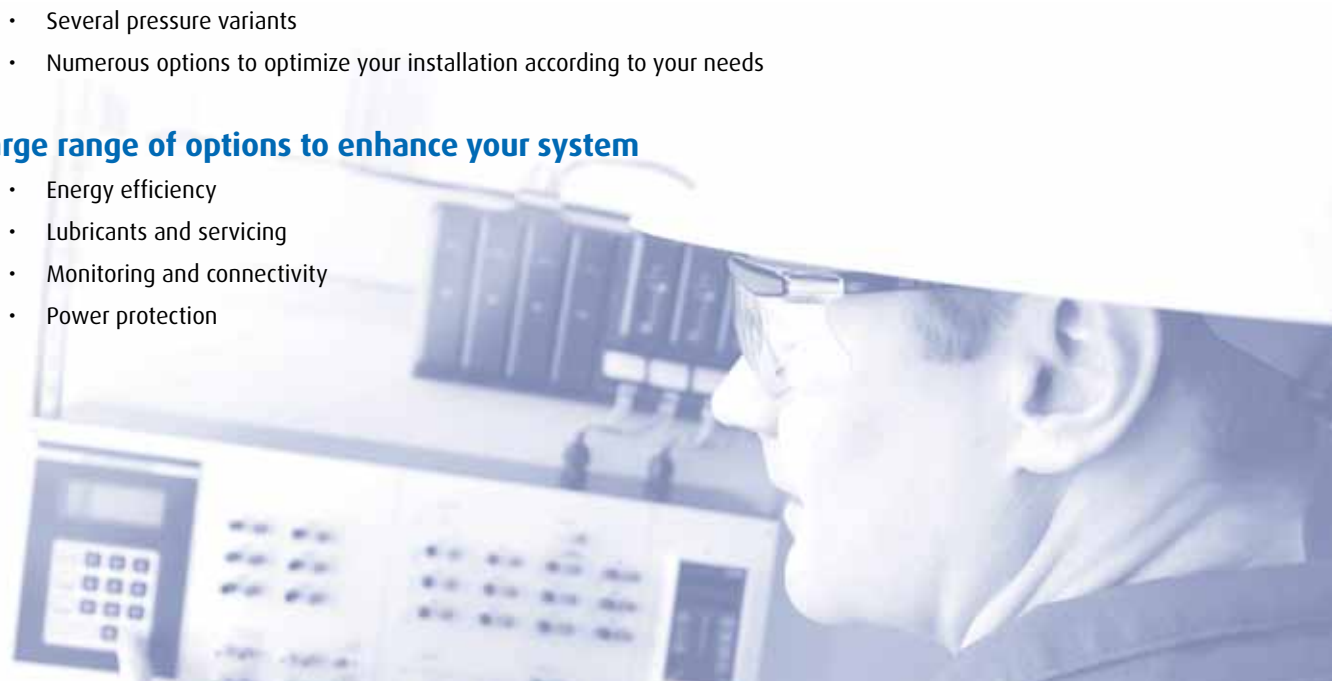

### Energy audit

To optimize your energy efficiency, you need to select the right compressor. Contact your local ALUP representative and we will perform a simulation based on your parameters to help you get the perfect compressed air solution.

# One package – multiple benefits

*Check out these innovative features of the Largo 200-250 range and see how they provide you with high efficiency, ease of maintenance, low noise levels and outstanding cooling.*

## Highly efficient drive train

The screw element is field-proven: meticulous processes are behind its outstanding performance. To reach the highest output in an eco-friendly way, it is coupled with an IP 55 motor. A gear-driven transmission enhances efficiency and reliability.



## Optimized cooling system

For reliable operation, the aluminium cooler block with a large surface area reduces the air and oil fluid temperature and avoids heat build-up inside the canopy. Ventilation fans guarantee a large cooling capacity with a minimum noise level.



## Easy and safe to service

Large opening panels ensure easy access to all parts. Cleaning of the coolers is easy without extra tooling. To change the air/oil housing, the cover of the separator vessel simply lifts and swings away. The controller provides info on the number of hours before the next service, for enhanced maintenance flexibility.

## Protective filtration system

To protect the internal components from dust contamination, a 2-stage air inlet filter stops particles of 3 micron entering the system. Large dust particles are captured by pre-filtration before the air passes through the high filtration media.





### Superior separation system

The separation system guarantees the lowest residual oil level in three steps: the action of gravity; pre-separation in the oil vessel; and filtration by the oil separator. The result is a fluids content less than 3 mg/m<sup>3</sup>.

### Integrated water separator drain as standard

A large diameter water separator drain ensures constant removal of condensate and prevents clogging even in humid conditions.



### Reliable operation in demanding conditions

A robust canopy and time-proven components ensure trouble-free operation. Machines are delivered ready to use without hidden costs. All connection points are located on one side for easy installation.



### Air Control 5.1

Smart, with intuitive navigation and a user-friendly graphic interface, the new Air Control 5.1 controller is the ideal management tool for your compressed air system. A large range of features is available to help you monitor, protect and optimize your installation.



## Options to optimize your operations



A wide range of options enables you to get the most out of your LARGO compressor.

- **Lubricants and servicing:** 4000 hours oil, 8000 hours oil or food grade oil
- **Phase sequence relay** to protect the motor and electrical equipment from electrical failure
- **Modulating control** to adjust the compressor flow rate using very slight pressure variations in the operating network
- **Electronic condensate drain** to make sure there is no air loss during condensate removal
- **SPM monitoring equipment:** Shock Pulse Measurement
- **PT 1000 Thermal Protection** provides further protection for the main drive motor
- **Anti-condensation heaters:** electric heaters are installed in the main motor windings and connected to the compressor cubicle
- **Wooden box packaging** for overseas transport
- **Energy recovery:** when air is compressed, heat is formed. The excess heat can be captured with an energy recovery option and channeled to other applications (showers, boilers, etc.) allowing energy and cost savings. The energy recovery option is a simple mechanical system that requires no maintenance or electricity consumption.

### Energy recovery principle

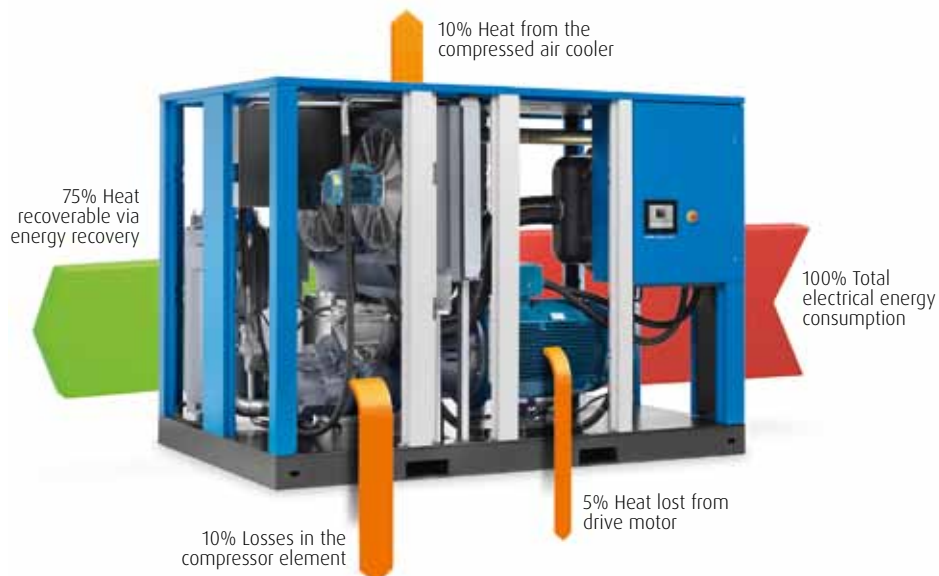

## Standard scope of supply

- Air and oil circuit
- Cooling fans for air cooled units
- High-resolution graphical controller
- Noise elimination enclosure
- Ductable air intake and discharge
- High-efficiency, insulation Class F TEFC/IP 55 motor
- Built-in star-delta voltage starter
- High-efficiency air inlet
- Water separator drain
- Air/oil separation system
- Structural skid

## Technical specifications

### 50 Hz machines

Model	Max. working pressure		Reference working pressure		Free Air Delivery at reference conditions			Motor power		Noise Level **	Cooling air Volume	Weight	Compressed air output diameter
	bar	psi	bar	psi	m <sup>3</sup> /min	l/s	cfm	kW	hp	dB(A)	m <sup>3</sup> /s	kg	(acc DIN 2633)
<b>LARGO 200</b>	7.5	109	7	106	35.5	592.3	1256	200	270	77	8.4	4710	DN100/PN16
	8.5	123	8	120	32.7	545.1	1155	200	270	77	8.4	4710	DN100/PN16
	10	145	9.5	142	30.8	512.6	1087	200	270	77	8.4	4710	DN100/PN16
	13	203	12.5	200	26.2	436.3	925	200	270	77	8.4	4710	DN100/PN16
<b>LARGO 250</b>	7.5	109	7	106	40.8	680.6	1443	250	340	78	8.4	4780	DN100/PN16
	8.5	123	8	120	40.0	666.9	1414	250	340	78	8.4	4780	DN100/PN16
	10	145	9.5	142	37.6	626.2	1327	250	340	78	8.4	4780	DN100/PN16

### 60 Hz machines

Model	Max. working pressure		Reference working pressure		Free Air Delivery at reference conditions			Motor power		Noise Level **	Cooling air Volume	Weight	Compressed air output diameter
	bar	psi	bar	psi	m <sup>3</sup> /min	l/s	cfm	kW	hp	dB(A)	m <sup>3</sup> /s	kg	(acc DIN 2633)
<b>LARGO 200</b>	7.5	109	7	106	35.1	585.6	1241	200	270	79	9.2	4670	DN100/PN16
	8.5	123	8	120	31.5	524.9	1113	200	270	79	9.2	4670	DN100/PN16
	10	145	9.5	142	29.0	483.1	1024	200	270	79	9.2	4670	DN100/PN16
	13	203	12.5	200	25.6	426.7	905	200	270	79	9.2	4670	DN100/PN16
<b>LARGO 250</b>	7.5	109	7	106	39.0	649.8	1377	250	340	79	9.2	4879	DN100/PN16
	8.5	123	8	120	37.0	616.5	1307	250	340	79	9.2	4879	DN100/PN16
	10	145	9.5	142	34.1	568.5	1205	250	340	79	9.2	4879	DN100/PN16

### Dimensions

Model	Length		Width		Height	
	mm	inch	mm	inch	mm	inch
<b>LARGO 200</b>	3386.0	133.3	2120.0	83.5	2400.0	94.5
<b>LARGO 250</b>	3386.0	133.3	2120.0	83.5	2400.0	94.5

Unit performance measured according to ISO 1217, Annex C, 1996.  
 Noise level measured according to ISO 2151: 2004 using ISO9614/2.  
 All technical data applies to air-cooled machines.  
 For technical data of water-cooled machines, please contact your local sales force.





**DRIVEN BY TECHNOLOGY DESIGNED BY EXPERIENCE**



**CONTACT YOUR LOCAL  
ALUP  
REPRESENTATIVE**

**Your authorized distributor**

69996 40280

[www.alup.com](http://www.alup.com)