

Modify Your Seam Phantom® to Fit Makita Model No. GA5042C/GA4542C (SJS II Grinders)

Starting In mid-October 2015 all new Seam Phantoms® will be modified to fit the recently introduced Makita SJS II angle grinders. The new Seam Phantoms® will continue to fit the original grinders as long as they are available. The new and old Makita model numbers are:

Makita Grinder Model Numbers for Seam Phantom Use		
	Old Grinder	New SJS II Grinder
5" Grinder	9565CV	GA5042C
4-1/2" Grinder	9564CV	GA4542C

An older Seam Phantom® can easily be modified to fit the new grinders per the following instructions:

1. Remove the seam phantom® from your old grinder by removing the following parts shown in Figure 1. A 3mm Allen wrench is required to remove the screws. *Save all parts for reinstallation on the new grinder:*
 - a. one (1) red, SL3 adapter
 - b. one (1) arbor spacer if present
 - c. four (4) 4mm x 22mm hex mounting screws (Allen drive)
 - d. one (1) splash guard
 - e. up to four (4) shim washers if present

Note - With the mounting screws removed the grinder head is not fastened together and will fall apart if the arbor is turned down. Use the screws from the new grinder to reassemble the old grinder if you intend to keep it.

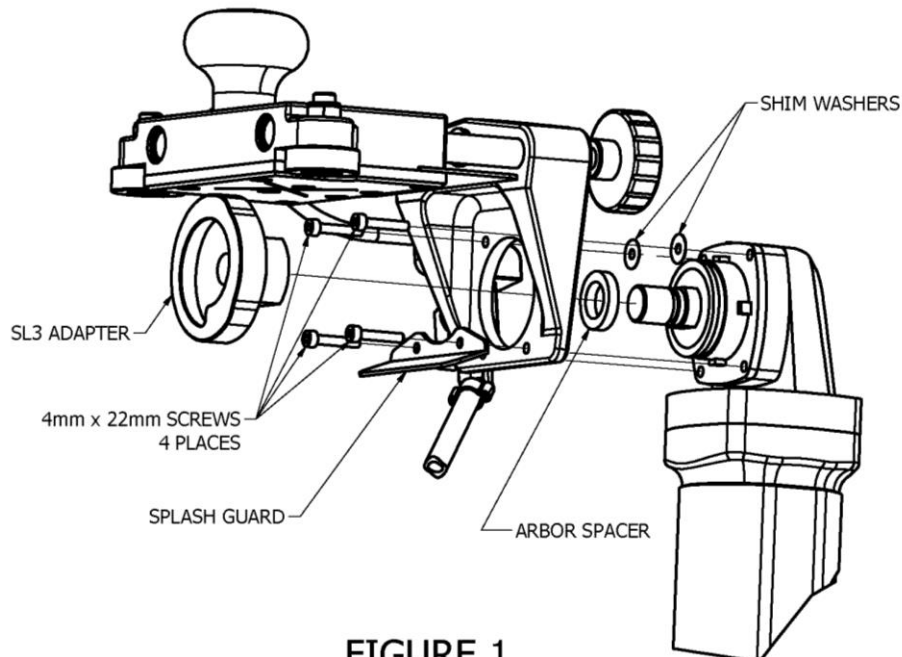

FIGURE 1

- Using a 3mm Allen wrench, remove four (4) 4mm diameter hex screws from head of the new grinder at the attachment locations as shown in Figure 1. Do not remove the grinding head. These screws can be used to reassemble the old grinder if desired
Note - With the mounting screws removed the grinder head is not fastened together and will fall apart if the arbor is turned down.
- Position the Seam Phantom® on the new grinder. Two screws on the new grinder will interfere with the lower edge of the Seam Phantom® as shown in Figure 2 and Figure 3. With the Seam Phantom centered on the grinder, mark the position of the interfering screws as shown.



FIGURE 2



FIGURE 3

- With a file, Dremel or other appropriate tool create a notch to provide clearance for the screw as shown in Figure 4 and Figure 5. The notch should be just over 1/16" deep and wide enough to provide clearance for the screws.



FIGURE 4



FIGURE 5

5. Additionally - There are raised part numbers on the face of the Makita that the Seam Phantom® sits against. These numbers will cause the Seam Phantom to sit out-of-square. The numbers are shown in Figure 6. The numbers can be filed flat (not sure if this is a warranty issue?) or alternately, small, #8 stainless washers can be used to provide a mounting surface above the raised numbers® as shown in Figure 7 and Figure 8.



FIGURE 6



FIGURE 7



FIGURE 8

6. With the notches cut and the part numbers either filed flat or washers placed at the attachment locations, screw the Seam Phantom and Splash Guard into place on the new grinder using the four (4) 4mm X 22mm Hex Screws removed in step 1. Tighten using a 3mm Allen wrench. At this point the original shim washers should be omitted until the unit has been tested and adjusted per step 8 below.
7. Reinstall the arbor spacer (if present) and the red, SL3 adapter.

8. The vinyl spray skirt can be salvaged from the old grinder and reinstalled on the new grinder using electrical tape around the upper edge

9. Final squareness adjustments to the Seam Phantom® should be accomplished per the original instruction manual section titled “Adjusting the Seam Phantom”. The original shim washers or similar substitutes will be used to make the adjustments if required. If you do not have the original manual it can be found on our website at www.nsisolutions.com .