

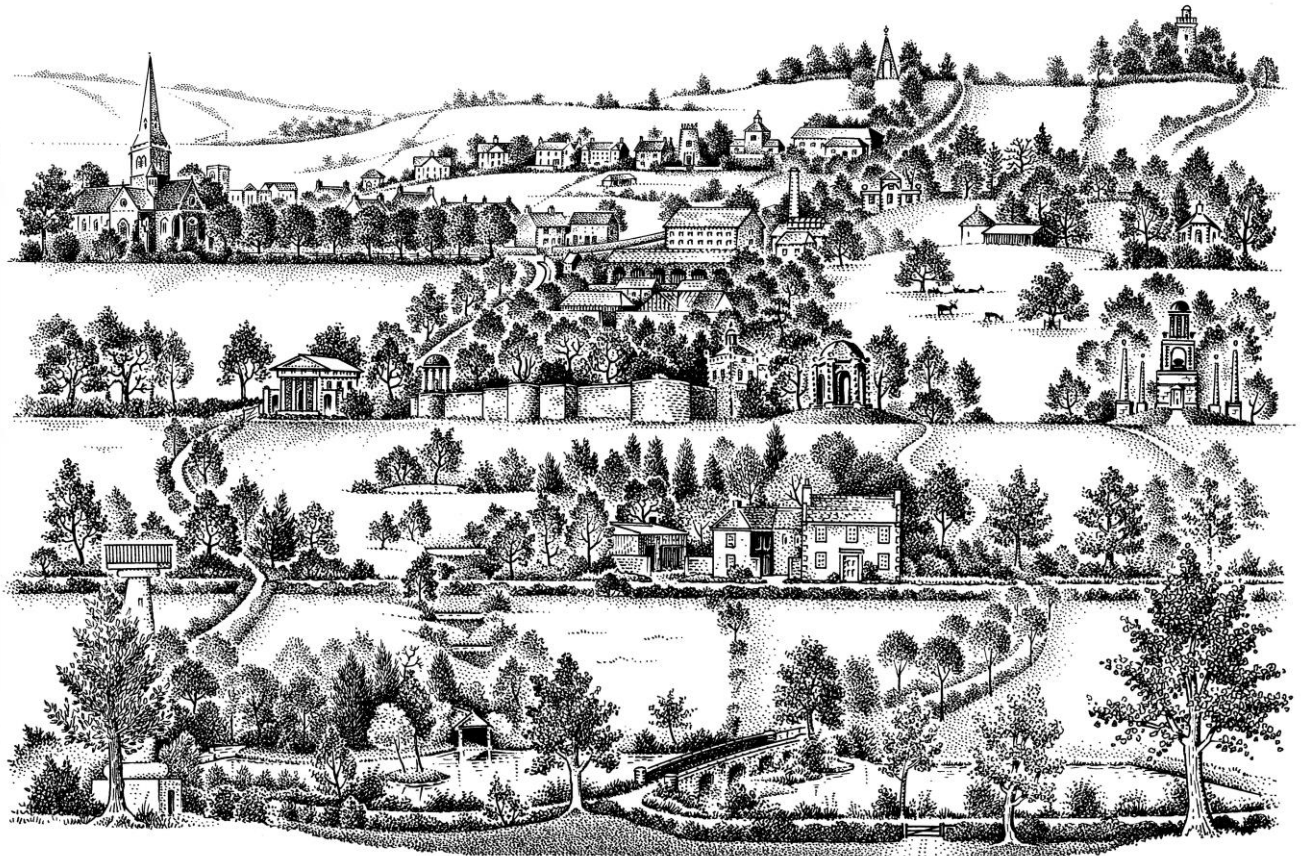

Fitzwilliam (Wentworth) Estates

Wentworth Village Design Guide



Commissioned by

The Fitzwilliam Wentworth Amenity Trust

2006

THE FITZWILLIAM WENTWORTH AMENITY TRUST

Village Design Guide

INTRODUCTION

The objective of this design guide is that it should contribute to an appreciation of the qualities of Wentworth village that are unique to it and therefore make it what it is. However, the village is a living community subject to the pressures of change and the need, over time, to repair and alter the existing fabric. An understanding of the architectural character and detail will ensure that those necessary changes are within the spirit of the place and that the character of the village can be conserved in an active and flexible manner.

HISTORICAL BACKGROUND

It is unclear whether the village of Wentworth or the great houses now known as Wentworth Woodhouse came first. The village is recorded in the Domesday Book as Winterworth and it is likely that, even then, it contained a 'head' house or manor. It was the marriage of the heirs of Wentworth and of Woodhouse in the 14th century that gave the house its present name. In 1782, on the death of the 2nd Marquess of Rockingham, the estate passed to the 4th Earl Fitzwilliam and Wentworth has remained in the custody of the Fitzwilliam family ever since.



The crucial point to bear in mind is that the village of Wentworth has been fashioned and perpetuated by the presence and needs of the Fitzwilliam Estates over many years. New buildings were created as they were required for the Woodhouse, the surrounding agriculture or local industry. There are definite stylistic and typological variations within the built fabric but, through the influence of the Fitzwilliam Estates, there is also a remarkable consistency of materials and details.



VILLAGE URBAN STRUCTURE

THE FITZWILLIAM WENTWORTH AMENITY TRUST
Village Design Guide

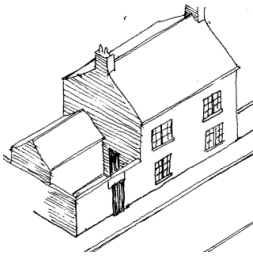

FACING STREET, SIDE ENTRANCE – Front door is off a side yard. Access to side yard is through a gate.

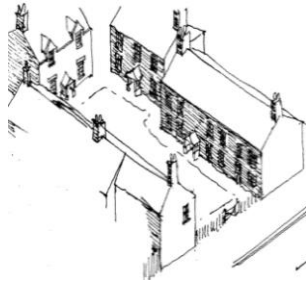

URBAN GROUP OFF STREET – Front doors all face into the central courtyard.

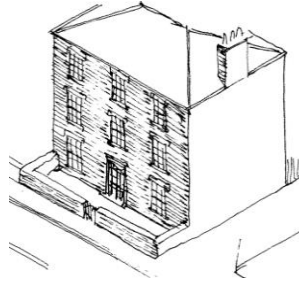

DETACHED HOUSE ALONG ROAD – Front door is typically central to the main elevation.

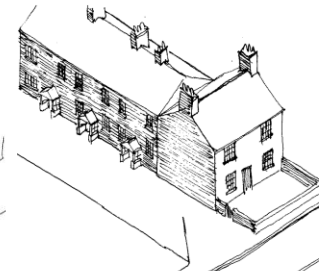

FRONTAGE BUILDING & PERPENDICULAR TERRACE – The symmetrical frontage building screens the less formal building behind

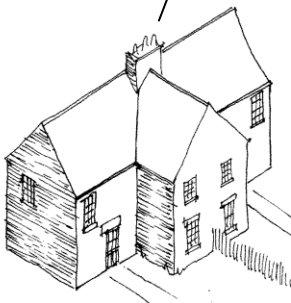

SEMI DETACHED HOUSES AWAY FROM ROAD – A 19th century type with an overall symmetry over two houses.

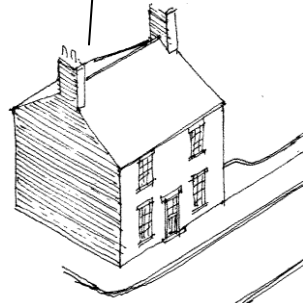

DETACHED HOUSE AWAY FROM ROAD – A type used away from the main road. Mostly 19th C.

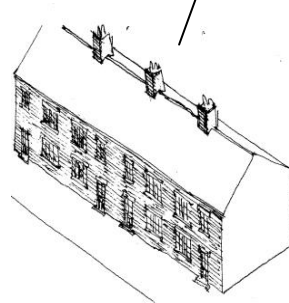

TERRACE PERPENDICULAR TO ROAD – A series of similar 'cottages' with front doors facing the lane. No front garden.

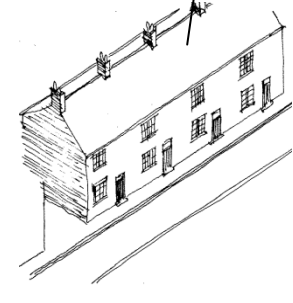

TERRACE FACING STREET – A series of similar 'cottages' facing the main street. No front garden.

THE FITZWILLIAM WENTWORTH AMENITY TRUST

Village Design Guide

VILLAGE URBAN STRUCTURE & TYPES OF BUILDINGS

The urban structure of the village is based around the relationship of individual buildings to Main Street and, to a different extent, Clayfields Lane. Although there are several building 'types' their relationship to the whole, as well as their individual articulation, is governed by their principal entrances from the public realm.

- The simplest relationship is a principal façade onto the street. This can occur if the building is detached, a terrace or some distance from the street.
- The second type of relationship is towards a secondary space such as a perpendicular lane or a specific feature such as Paradise Square.

The architectural expression of the individual buildings is governed by their orientation. Finer features and materials are placed towards the 'front' of the building and lower quality construction is to the 'rear'.

ARCHITECTURAL DETAIL

Wentworth contains a clear and restricted palette of architectural details and building materials. To maintain the character of the village, their use must be correctly executed and appropriate to the hierarchical location on the building and the general urban context.

Typical building elements are listed and described in sections as referenced below.

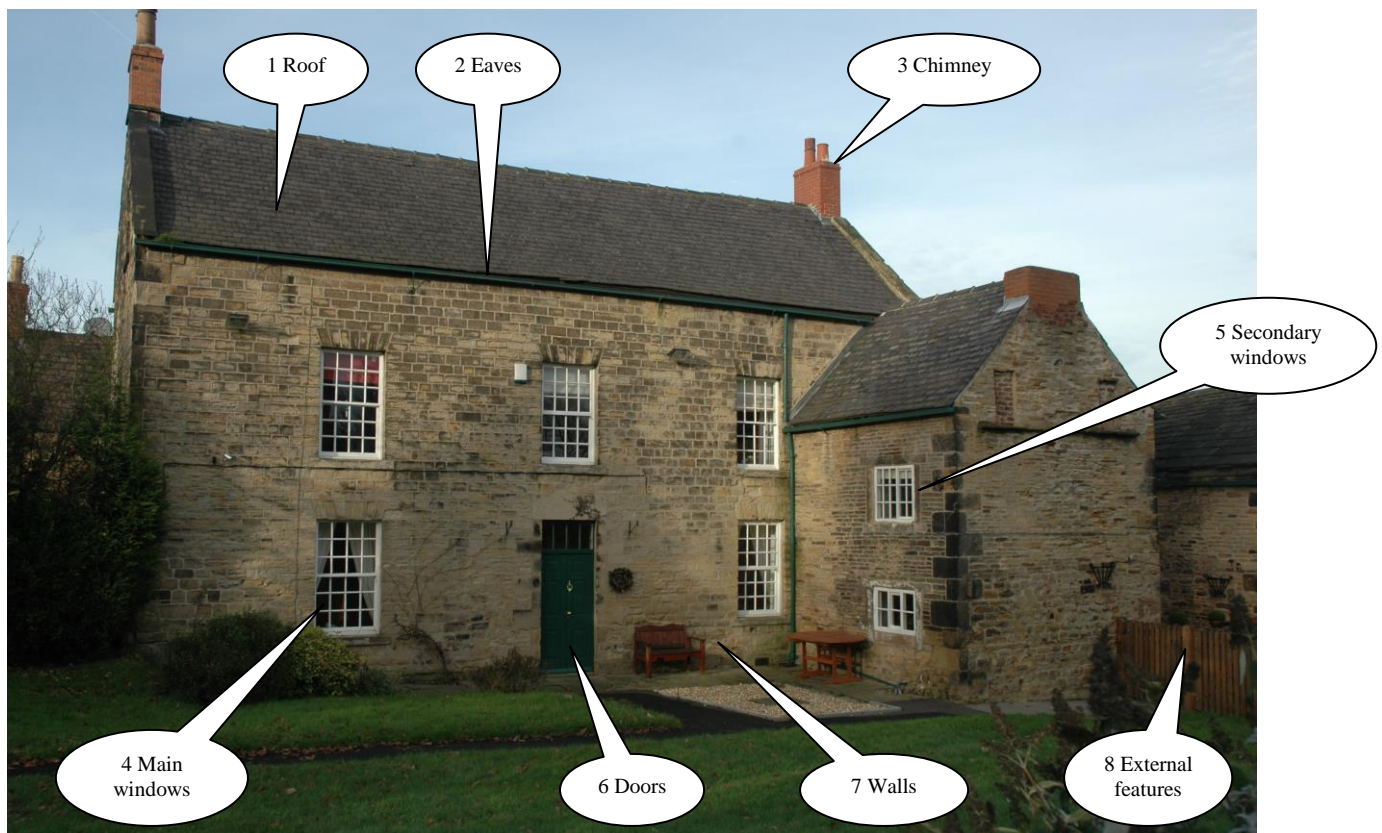

SECTION 1 – ROOF

Most roof forms are of a double pitch over a rectangular building with a central ridge. Additions to the main form continue the double pitch or turn through 90 degrees. Minor additions are often single pitch 'lean-to' structures but at a comparable pitch.

The principal roofing material used in the village is stone slate laid in diminishing courses on a pitch of approximately 40 degrees and with a stone ridge cap. Blue grey Welsh slates are present on a few 19th century buildings or as replacement for earlier stone slates (the eaves course of stones often being retained). Clay pantiles are sometimes used on outbuildings and at the rear of some houses but these too, are a replacement for stone slates and are detrimental to the aesthetic cohesion of the village.

Plain gable ends terminate most roofs with the edges of the stone slates supported by a cement fillet. There are also several buildings with a shallow gable parapet supporting stone capping and pronounced ogee eaves projections.

Notes

Stone slates to be fixed with hardwood pegs (not dowel) on 25 x 50 preservative treated softwood.

Ridge tiles to be bedded and joined in a lime putty / sand mortar.



THE FITZWILLIAM WENTWORTH AMENITY TRUST
Village Design Guide

SECTION 2 – EAVES



A principal characteristic of the village is the use of square section timber gutters, painted green and mounted on metal rise and fall brackets. There are also rare Victorian instances of these gutters being placed on wooden or stone corbels for a more 'classical' effect.

Traditionally there are no fascia boards or eaves soffits.

Almost all rainwater downpipes are round in section and made of cast iron. Cast aluminium could also be used as a replacement.

Notes

Wooden gutters should be fabricated from a resilient but paintable timber such as iroko.

Verges to be pointed in lime putty / sand.

Flashings and abutments to be in code 4 lead on a non-woven geotextile separation layer.

Ensure firm base and ventilation.

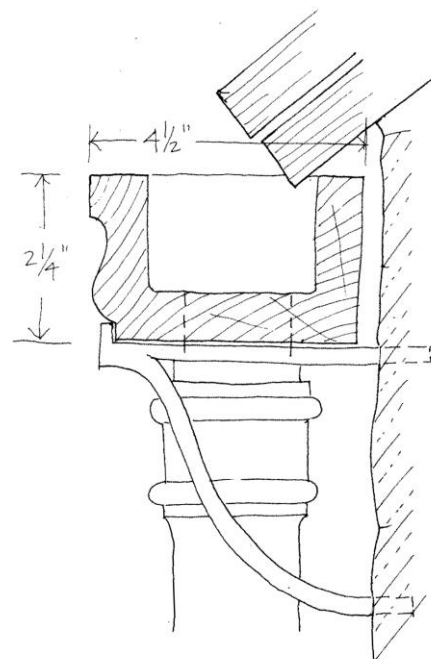

THE FITZWILLIAM WENTWORTH AMENITY TRUST Village Design Guide

SECTION 3 – CHIMNEYS

Chimney-stacks in Wentworth village are generally constructed of brickwork laid in a stretcher bond in an overall proportion of about 1 to 2 on the narrow side. They are almost invariably placed on the ridge of the building either at the gable end, over a significant internal wall or over a party wall to a terrace.

There are a few stone chimneys constructed on 19th century buildings such as the school. These can be square stacks but are often expressed as a series of joined shafts after the fashion of the day. Their greater decorative effect makes them suitable for public buildings.



Notes

Suppliers – Red Bank (www.redbankmfg.co.uk)

SECTION 4 – MAIN WINDOWS

Main windows are characterised as being on the ‘front’ of the building and facing the public realm (be it the road, lane or square).

Sash windows

Wentworth has an abundance of double hung vertical sliding sash [DHVSS] windows. Most have a configuration of 6 small panes (2 high by 3 across) to each sash but shorter windows with unequal sashes (3 in the outer and 6 in the inner sash) are encountered on the upper floors. There are a few examples of Victorian sashes (often fashionable replacements for earlier examples) that have only a single vertical glazing bar to each sash as well as the occasional unsatisfactory sash with a single piece of glass. The proportions of the glass pieces vary but are generally about 1 to 1.4 vertically. There are examples where this increases to 1 to 2 but this is less pleasing.



THE FITZWILLIAM WENTWORTH AMENITY TRUST

Village Design Guide

Most glazing bars are of medium width varying from 25mm to 32mm in profiles indicated on the sketch.

The majority of Wentworth's DHVSS windows are set in shallow reveals with the external face of the sash box showing and painted in, with the rest of the window, in white. The alternative, less common arrangement, is set the window frame within and behind deep reveal projections.

Casement windows

Many of the buildings of lesser visual importance have aligned and symmetrically arranged side hung casement windows on their main elevations. They are usually arranged as a pair of handed casements with hinges on the outer frames and a meeting post at the centre. Authentic windows have their sashes recessed into rebated frames and are set flush on the outer face. They have the visual characteristic of medium width mullions and thick frames.

The proportions of the glass pieces vary but are generally about 1 to 1.4 vertically. There are examples where this increases to 1 to 2 but, as with the DHVSS windows, this is less pleasing. The glass pieces are generally arranged in each sash either as 6 lights (2 across and 3 high) or, on the ground floor as 8 lights (2 across and 4 high) but there are examples of very large sashes of 12 lights.

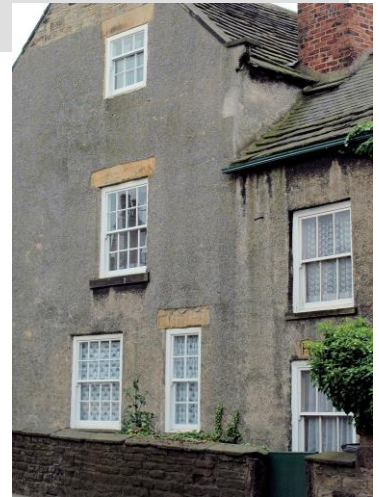

Cills & Lintols

All windows have deep stone lintols and cills.

The prevailing lintol type is a substantial rectangular stone but there are many examples where this has been scribed with joint lines to give the impression of a segmental lintol. There are, of course, several 'true'

segmental lintols constructed of irregular 'squared' stones as opposed to ashlar.

Notes

New and replacement windows should be manufactured from iroko and painted using the Dulux Weathershield oil based system.

All new and replacement windows are to have high quality brass hinges, catches and casement stays. DHVSS windows are to have brass pulleys, catches and lifting eyes. The lifting mechanism is to be by weighted cords.



THE FITZWILLIAM WENTWORTH AMENITY TRUST

Village Design Guide

SECTION 5 – SECONDARY WINDOWS

Principal windows are discussed in Section 4. Secondary windows are those classed as being to the rear of a property of occupying a less important location or aspect.

Casement

Secondary windows are almost always wooden side hung casement lights regardless of the type of principal window. Hierarchy is often also expressed in the arrangement of windows with secondary elevations having a more asymmetrical pattern.

Other windows

There are few horizontal sliding sash windows as well as a variety of agricultural lights scattered throughout the village. These are confined to rear or ancillary areas.

Notes

All new casement windows should be single glazed and with casements recessed within the frames.

New and replacement windows should be manufactured from iroko and painted using the Dulux Weathershield oil based system.

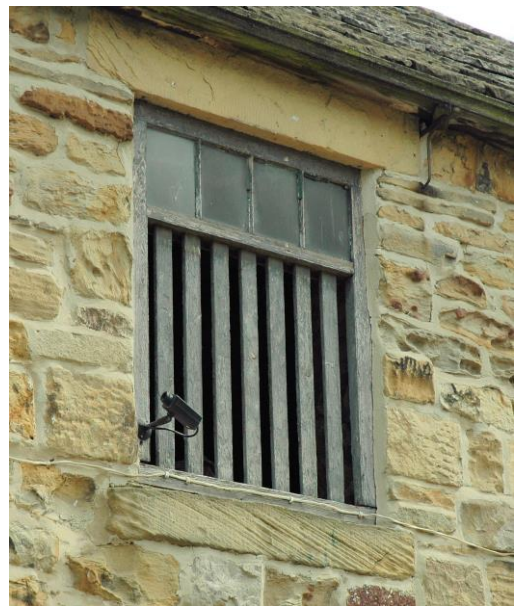

SECTION 6 – EXTERNAL DOORS

Half Glazed

A substantial proportion of external doors within the village are made of painted timber with the upper half glazed (usually with glazing bars) to provide light to the hall within. This arrangement is a recent ‘innovation’ and is completely at variance (see photograph) with the otherwise robust nature of the local vernacular. It should be discouraged.

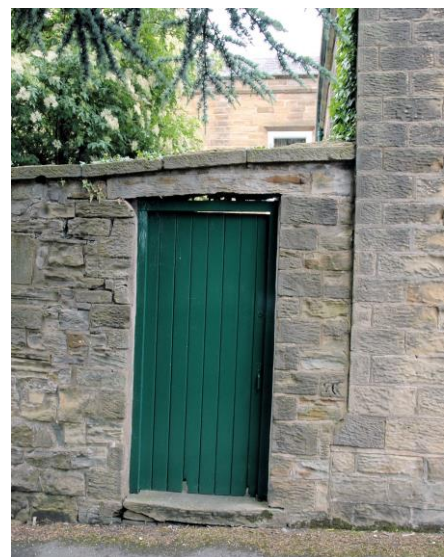

Inappropriate door insertion

THE FITZWILLIAM WENTWORTH AMENITY TRUST Village Design Guide

Vertical boarded

Framed, ledged and braced doors with vertical boarding are often used as the principal door to a dwelling. Where the principal entrance is through a side yard, access is almost invariably via a vertically boarded gate with the 'actual' front door (often partly glazed) being hidden from the street.

Panelled doors

A small proportion of entrance doors (especially in 19th century houses) are panelled. Care has to be taken in ensuring that this door type is both well proportioned and appropriate for the building.

Porches and canopy hoods

Where space permits, it is common to find a porch erected in front of the main building to provide shelter for the main entrance door. These porches are typically 'home made' and usually consist of a lightweight glazed timber structure on a stone plinth. There are also several simple canopies. It is felt that the variation and poor quality of many of these structures detracts from the strength and coherence of the buildings. Therefore, new 'model' designs for more substantial porches and better canopies are shown in appendix 1

Windows, including those in porches, are typically painted white. Doors and doorframes are usually painted dark green (BS 14C39).

Notes

For design guidance on the construction of new doors and porches see appendix 1



SECTION 7 – WALLS

The overwhelming majority of external walls within the village are constructed only of the local sandstone (grit stone). There are several buildings that have a variety of materials (mostly stone and render) where the stone deteriorated and was simply covered. Generally, only outbuildings are constructed of brick or timber.

Stone

Sandstone is an excellent building material but is vulnerable to attack from water, pollution and inappropriate maintenance. A solid stone wall functions by absorbing moisture during wet or wintry conditions and releases it during dry and warm periods. To effectively do this, it should be sufficiently thick, present few horizontal ledges and be vapour permeable through the use of lime putty/sand mortar.

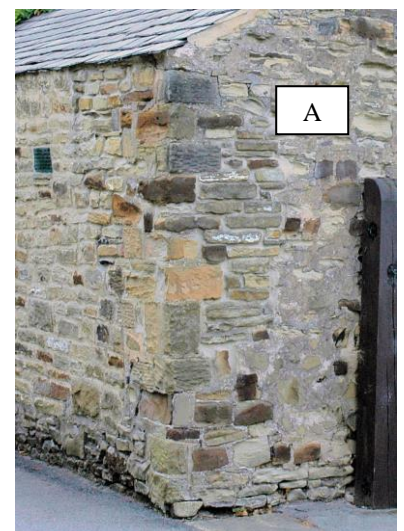

THE FITZWILLIAM WENTWORTH AMENITY TRUST

Village Design Guide

It is likely that much of the deteriorated stonework was caused by acidic pollution during the industrial era. This had the effect of ‘hollowing’ out individual stones through the effects of the acid and, once the process has been started, by frost action. This has been exacerbated by the introduction of cement-based mortars (instead of lime based) in repair and pointing. Cement mortar is water resistant and forces the moisture to evaporate through the stone face (where it does the damage) instead of through the joints.

Although the stone material is generally uniform, the village has a variety of rubble walling work that can be characterised as follows:

Random Rubble - *Uncoursed [A] or Built to courses [B]*.
Squared Rubble - *Built to courses [C] or Regular coursed [D]*.

The front or public face of any building is usually presented with squared rubble or random rubble built to courses. Rear extensions and outbuildings are sometimes constructed of uncoursed random rubble. The highest quality rubble stonework in the village is from the 19th century with squared and coursed stones and tight joints. Correct identification of the stonework type is vital in places where repair and re-instatement is being made.

Notes

All repairs and repointing should be carried out in a mixture of lime putty and sand. The mortar should be coloured only by the sand or the introduction of pozzolanic additives if required in exposed locations.

Stones should be replaced on an individual basis. If greater areas require repair, consideration should be given to reconstruction of the wall face with plain tiles exposed on end in a lime mortar matrix.

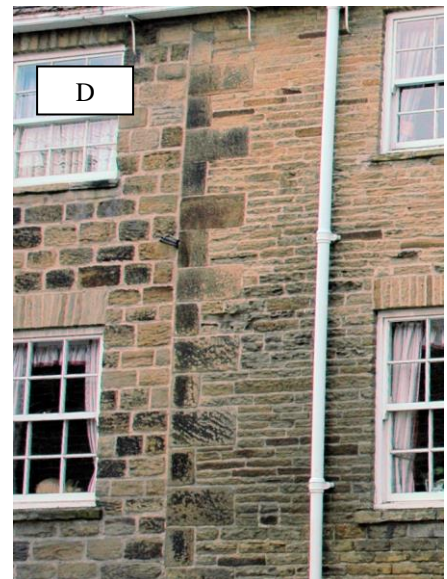
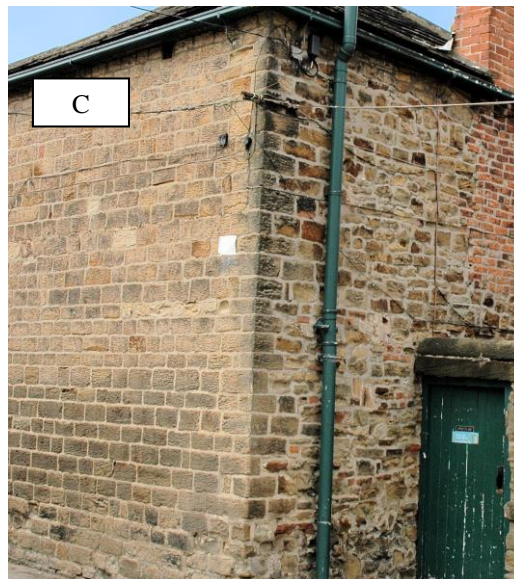
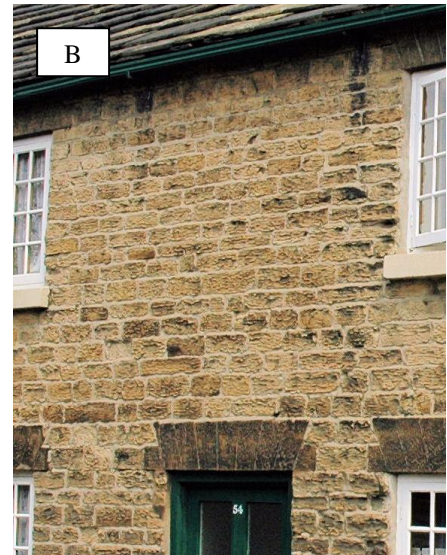

SECTION 8 – EXTERNAL WALLS, FENCES & PAVING

The treatment of external built features is a crucial and often overlooked aspect of architectural character. In many places where the buildings are set back from the street, the public realm, the crucial enclosure is formed by

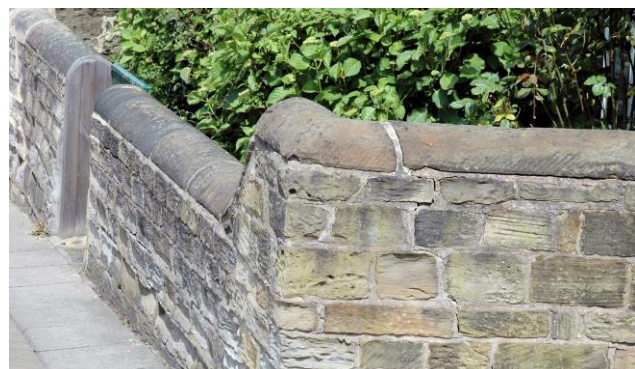

THE FITZWILLIAM WENTWORTH AMENITY TRUST

Village Design Guide

stone walls and, in several places, by metal railings. Regrettably, there are places where wooden picket fences have been inserted. There are also locations where informal areas of stone setts, gravel or garden have been replaced by tarmac and the intrusion of heavy traffic along the street is a problem.



Stone walls, an authentic feature of Wentworth, are most commonly built of random rubble, either and most commonly coursed or uncoursed, depending on the context and era of construction. The wall is most commonly weathered by a half round stone cap in a matching stone. There are instances of a flat cap and, in agricultural contexts of vertical rubble stones.

General notes

All windows are to be painted brilliant white.

All gutters, external doors and miscellaneous features are to be painted in Holly Bush Green (B.S. 14C39).

External and internal door ironmongery to be cast / wrought black iron from The Anvil (www.fromtheanvil.co.uk)

AUDIT OF ARCHITECTURAL FEATURES WITHIN VILLAGE

Roof Stone slate – 55%, Welsh slate – 33%, Mixed- 7%, Concrete tiles- 3%, Clay tiles – 1%, Unknown – 1%

Eaves /gutter Wooden – 92%, Cast iron – 3%, Plastic –3%, No gutter – 2%

Chimneys Brick – 64%, None – 16%, Stone – 15%, Mixed brick & stone – 4%

Windows Timber casement – 40%, Vertical sliding sash – 37%, Modern –11%, Other – 12%

Doors Half glazed – 44%, Vertical boarded –23%, 4 or 6 panel – 14%, Stable – 4%, Modern replacement – 4%, Other – 11%

Walls All stone – 62%, Stone & render – 27%, Render – 7%, Brick – 4%

Principal External Feature Stone wall 45%, Tarmac – 14%, Picket fence – 12%, Garden – 12%, railings – 4%, Steps – 3%, None –10%

APPENDICIES

1. Porches, canopies and doors
2. Garage Buildings

THE FITZWILLIAM WENTWORTH AMENITY TRUST
Village Design Guide

APPENDIX 1

PORCHES AND DOORS

A principal architectural characteristic of Wentworth is its simple forms and robust stone construction. In recent decades there has been a fashion of constructing porches in front of entrance doors. Whilst this provides shelter it can, if poorly executed, detract from the overall character of the building especially if the porch is 'home-made' and of lightweight materials such as glass and wood.

Without imposing a prohibition on lightweight porches (which might be appropriate in certain locations) a presumption in favour of stone porches with vertically boarded doors (as indicated below) should be assumed. In certain circumstances, depending on the location and character of the building, it might be more appropriate to fit a painted panelled door.

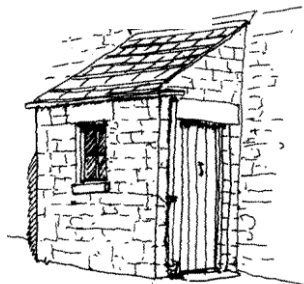
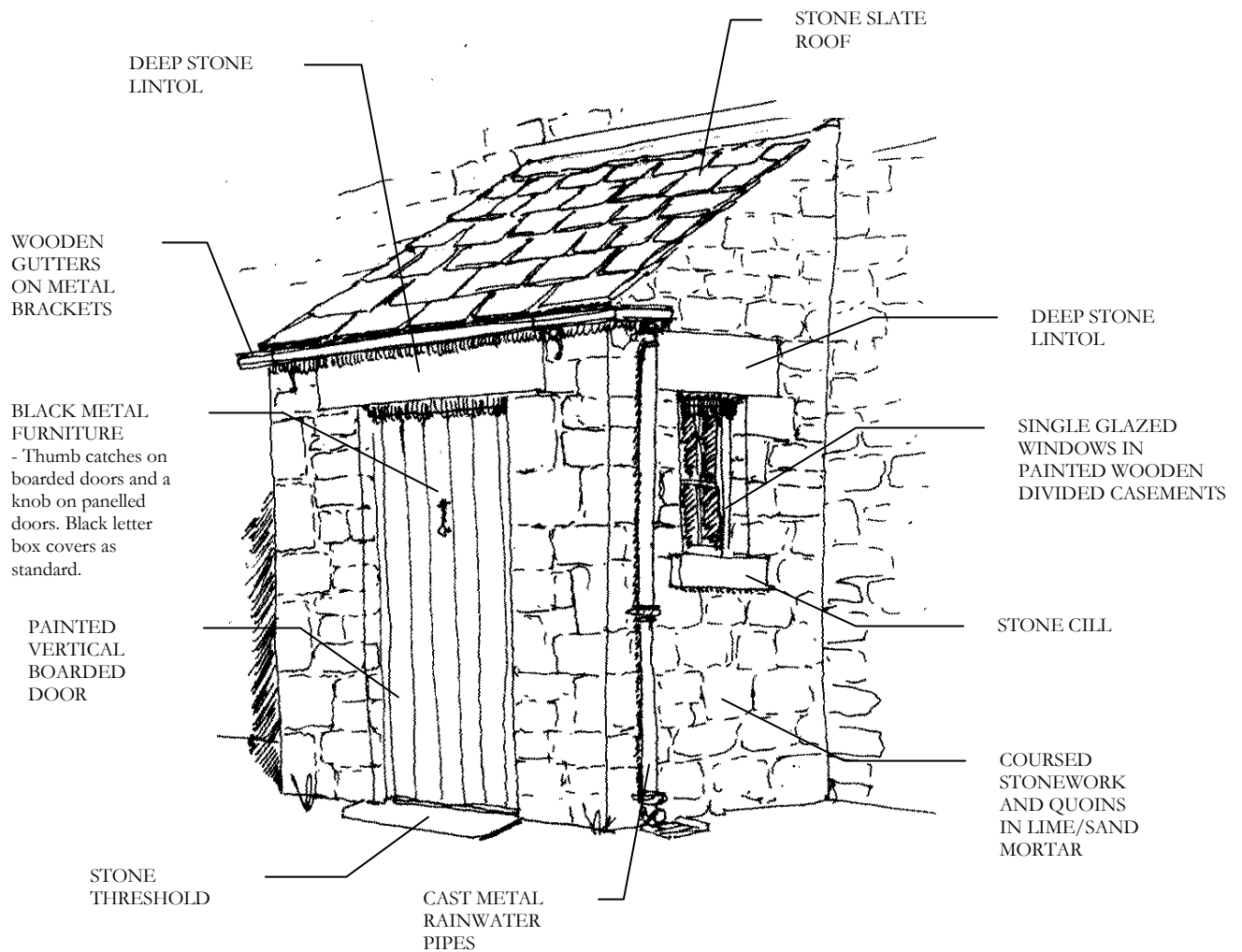

Variations on the same type are possible to give flexibility of arrangement.

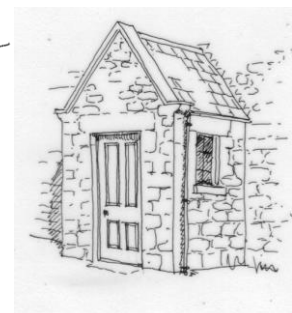
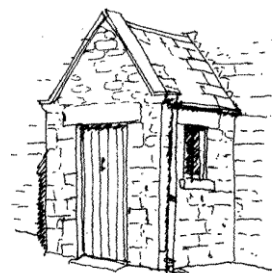

CANOPIES

In situations where space or the character of building does not allow for the construction of a fully enclosed porch, consideration should be given to providing shelter at entrance doors by means of a plain canopy. The canopy should consist of two brackets and a roof. The brackets should be made of stone or wood and the roof should be simply pitched (with a stone or slate covering) or flat (with a lead covering).

The detailed design of the canopy should reflect the architectural character of the building but it should also take into account the hierarchical situation of the door opening. Thus front doors opening onto the principal public realm could have more classical detailing than doors onto side roads or those at the rear of buildings.

A canopy with open brackets and a mono-pitched roof suitable in secondary locations.

2

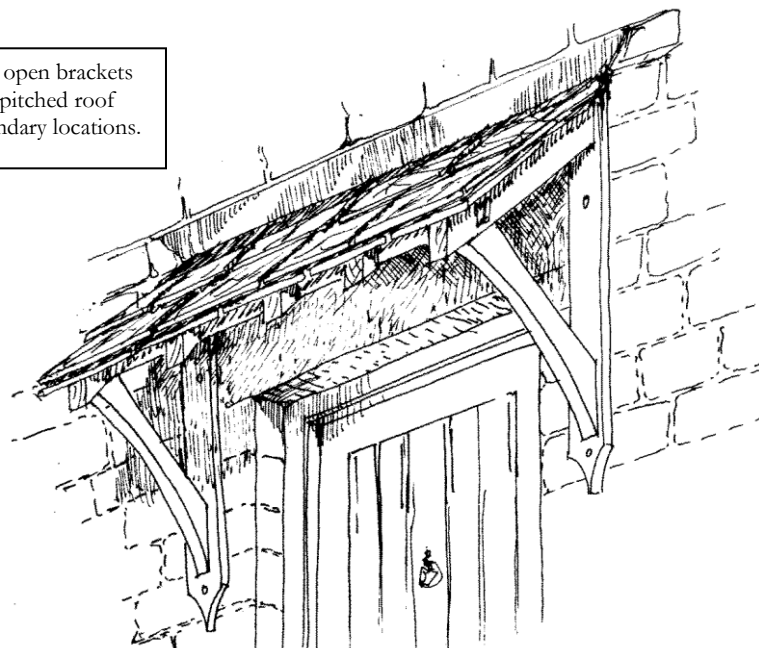

GARAGE

Garage should be sited and to be of importance their built they should maintain a

A classically detailed canopy with solid brackets and a flat roof for primary locations

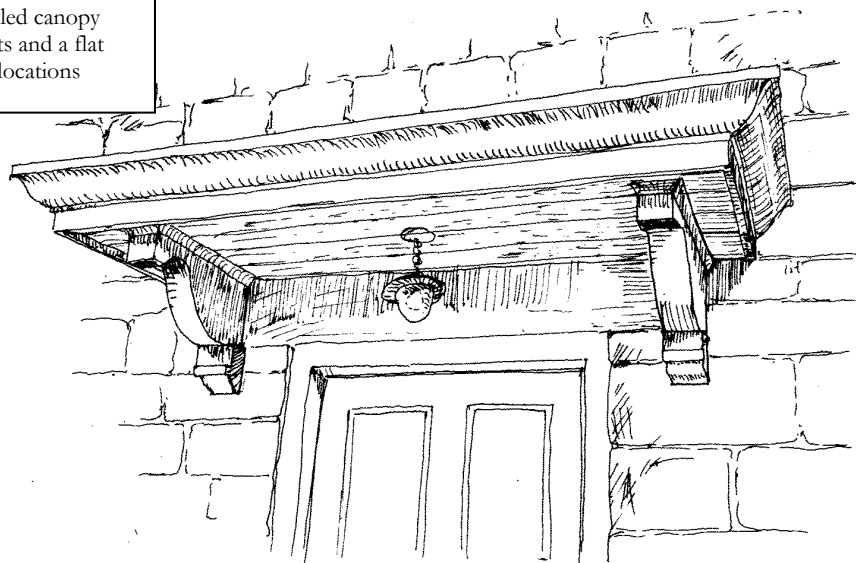

APPENDIX

BUILDINGS

buildings always be constructed secondary in relation to surroundings. Nevertheless,

and

surrounding buildings by the use, at least partly, of similar materials.

GARAGE BUILDINGS

The principal key to a successful design is to maintain a simple two-pitched form over a rectangular plan. The entrance can be set in the gable or the side elevation depending on practicalities but the impression of a thick walled structure, with recessed opening and wall returns, is very important.

Although the function of a car garage is relatively new, it is functionally allied to traditional ancillary and agricultural structures. Proposed designs for new garage buildings should follow the detail of the many agricultural and early industrial buildings to be found in and around Wentworth.

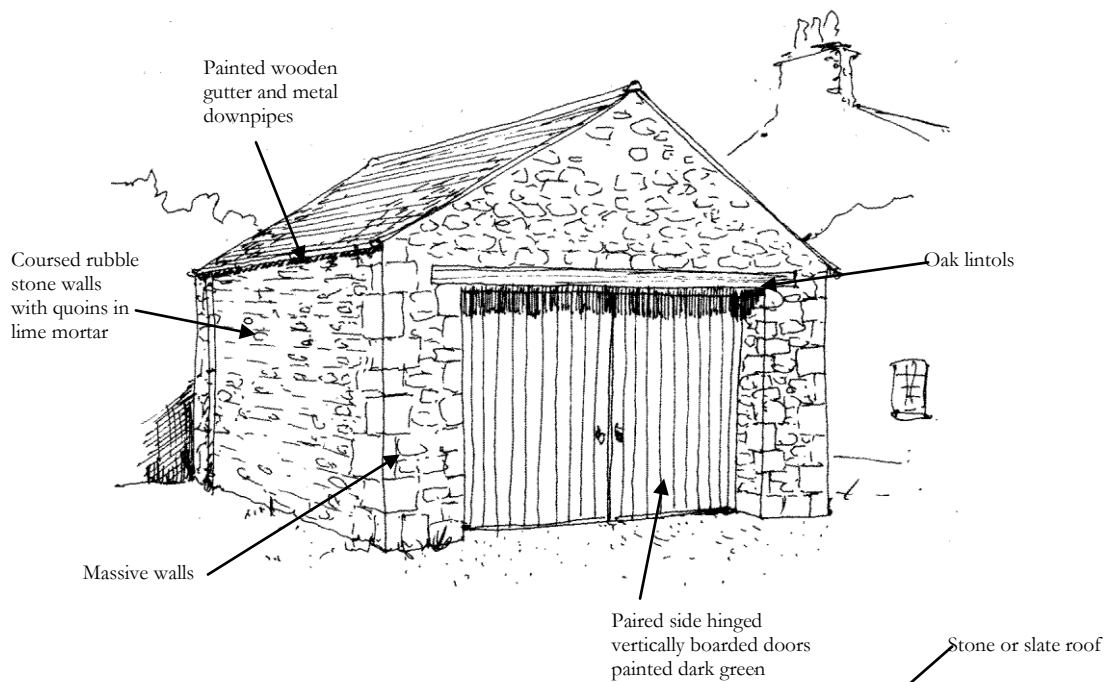

3.

