

# S1 Sequential

Sequential shifter

Contents and assembly instructions

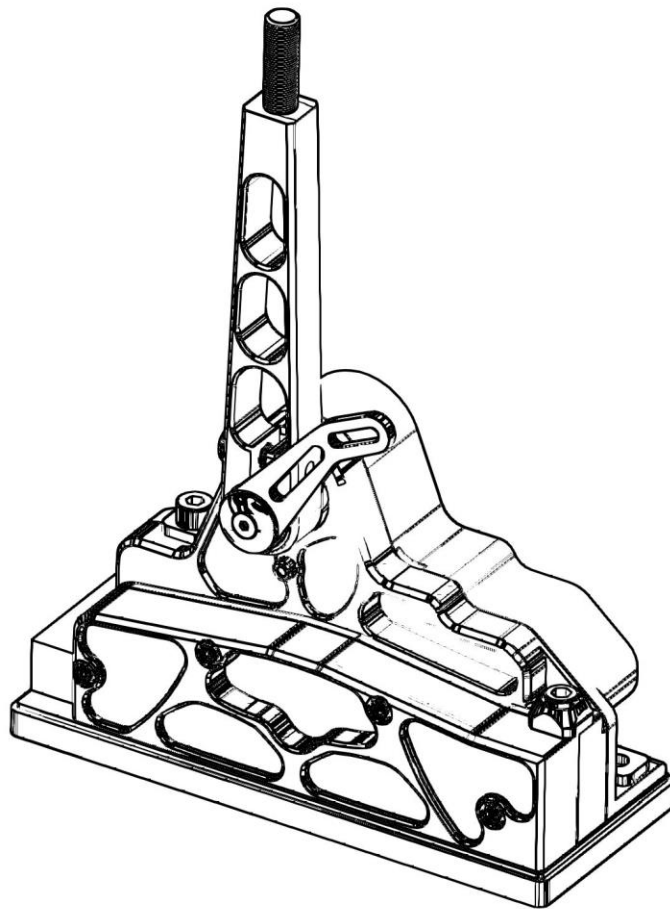

## Parts List

Sequential shifter x1



Base plate x1



Base spacer x1



Drill Square x1

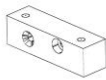

Shaft fitting x1



Square washer x4



Reverse lockout cover x1



M8x12 (reverse cover) x1



M4x8 (rps) x2



M5x25 (drill square) x1



M5x30 countersunk (drill square) x1



M8x16 countersunk (base plate to gearbox) x3



M8x35 hex (front left mounting bolt) x1



M8x35 socket head (rear left mounting bolt) x1



M8x80 socket head (rear right mounting bolt) x1



M8x60 socket head (front right mounting bolt) x1



M12x50 grub screw (top of lever)



Roll pin 6x32 (drill square)



Please read instructions fully before fitting

## **Installation**

1. Remove old shifter and offset lever. The offset lever is the cast part that is secured to the selector shaft with a roll pin.
2. Remove factory electronic reverse lock out and fit supplied cover with sealant.
3. Fit shaft fitting in place of offset lever with the 3/16<sup>th</sup> inch roll pin

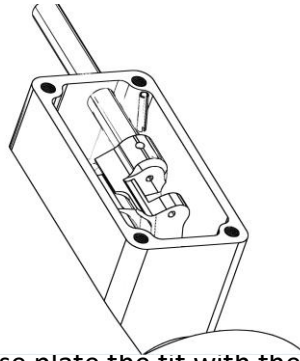

4. Apply a thin sealant to the base plate the fit with the three 8x16mm countersunk bolts.

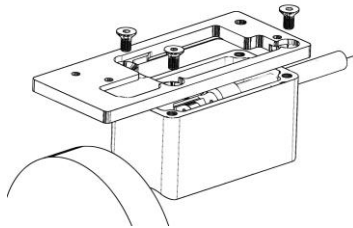

5. Fit base spacer with a thin layer of sealant.

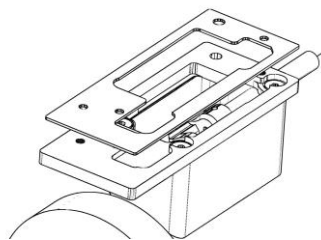

6. Observe how the shifter functions especially how the reverse selector works. The shift pattern is  
N-1-2-3-4-5-6.  
Pulling the back shifts up gears. Pushing the lever forwards shifts down gears.  
Neutral is only a half shift to the stop under 1<sup>st</sup> gear and must be selected softly  
shifting hard to neutral may damage the shifter or make reverse selection difficult.

To select reverse first down shift to neutral then move the lever clockwise when viewed from the right side of the shifter, once the lever has moved up 3 clicks through the internal gate the main shift lever is pulled back to engage reverse gear. To select neutral gear from reverse, push the main lever forwards a half shift to the stop then move the reverse gear selector anticlockwise. Be sure the reverse selector has been moved the whole way before engaging 1<sup>st</sup> gear. It may be fiddly at first but it's very quick and simple once it's been done a few times. Never force the reverse selector if it doesn't move easily select a gear again and gently re-select neutral.

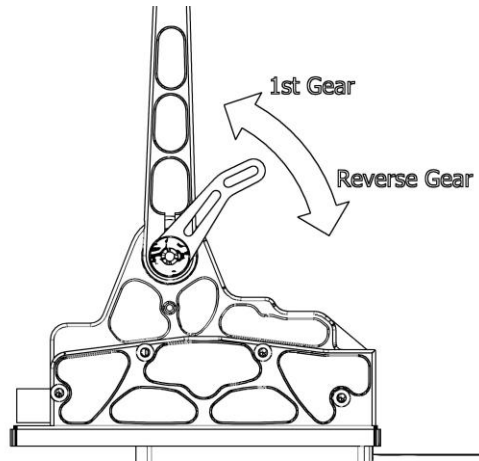

7. The reverse selection lever can be mounted facing forwards or backwards to suit the vehicle.
8. Attach the part "drill square" with the M5x25 cap head bolt and the M5x30 countersunk bolt as pictured.

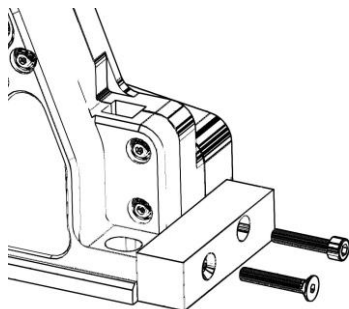

9. Put the gearbox in neutral gear and rotate the selector shaft all the way to the reverse position.
10. Put the shifter in the neutral position. Shifting may be difficult when the shifter is not mounted in the car. It is easiest to hold the lever and push the front of back edge of the shifter on a solid surface.
11. Move the reverse selector to the 1<sup>st</sup> gear position and observe the side shift arm moving down.

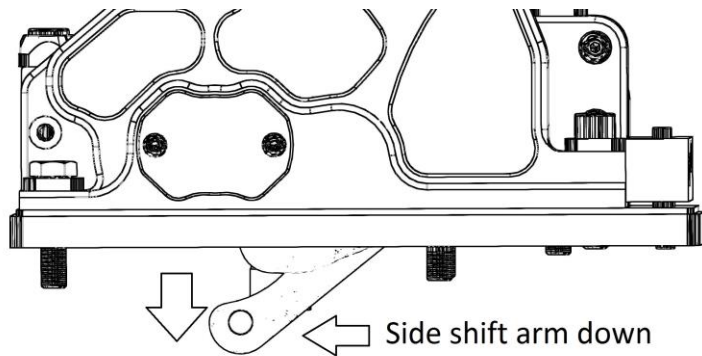

12. Slide the ball shaped fitting on the side shift arm into the groove on the left side of the shaft fitting as you lower the shifter onto the base plate. Check that the shifter slides all the way flush with the base, do not force it down with bolts.

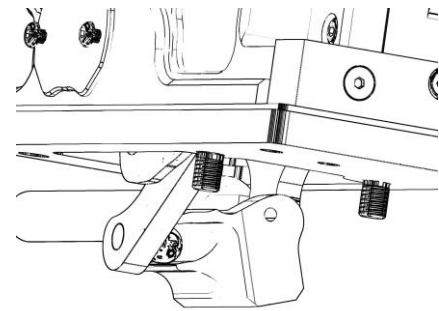
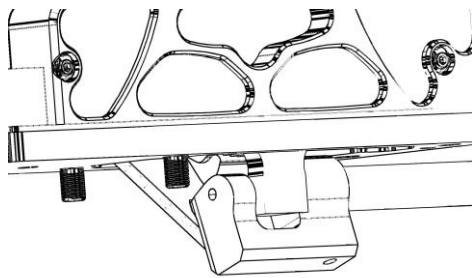

13. Fit and slightly tighten the three 8mm cap head bolts to attach the shifter to base plate then rotate the reverse selector back and forth a few times to get a feel of it. Rotate the reverse selector all the way to the 1<sup>st</sup> gear position and you should now be able to select gears. If the shifter has not been placed exactly in the centre it may jam or get tight to move near the end of lever travel it is often most obvious when you go to change out of that gear where it will be much harder to move than in the opposing gear, this indicates that you needhaha to move the shifter very slightly back or forth. If the problem is on an odd number gear you need to move the shifter slightly forwards, if the problem is on an even numbered gear move it slightly backwards. Take your time with this get it right the first time then tighten the bolts and check it shifts as it should in all gears.

14. Once you are certain its correct drill two 6mm holes in the drill square and through the base spacer for the 6mm roll pins. Be careful not to drill through the mounting bolts securing the drill square to the shifter body.

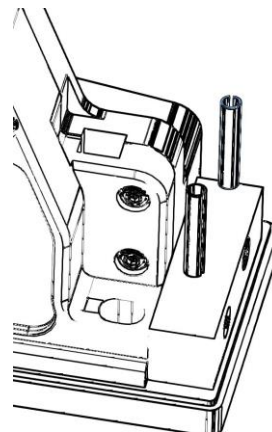

15. Remove shifter and apply a thin sealant refit bolts finger tight and fit the roll pins to locate the shifter then fit and tighten all 4 shifter bolts.
16. If needed the lever handle can be adjusted for angle. If you cannot easily rotate the handle once loosened removed the bolt and insert it from the other side with a piece of metal inserted to cover the hole in this way the bolt its self can be used to loosen the grip on the shaft.

If you have any issues with the shifter or electronics please contact us even if you are unsure if its faulty or an error on your part and we will find you a solution.

### **Things to remember**

1. A gearbox with any shifter fitted may not shift through all gears when the car is not moving. A lot of people don't notice this as with a H-pattern shifter there is no motivation to shift through all 6 gears while stationary. It may be necessary to release the clutch slightly with the engine running while engaging each gear so the internals can rotate and line up. A lot of t56 show this the most on reverse gear.
2. Clean transmission fluid is very important in these boxes and it wears out fast when driven hard.
3. Clutch operation is also very important many cars have poor shift just from the clutch not fully disengaging. If the car moves forwards even a little when first gear is engaged the clutch is not fully releasing. Clutch fluid also gets old and causes issues in a lot of cars.
4. It's probably possible if you tried hard enough to break the reverse selector lever so please don't force it these will not be covered under warranty.

### **Shifter removal**

1. Use a punch to knock the roll pins all the way out of the base plate.
2. Undo the 4 mounting bolts and remove

### **Gear position sensor fitment**

The shifter comes with a magnet installed, the position of this is read through the case of the shifter with a hall effect rotary position sensor. To fit simply attach the sensor with the M4x8 bolts while trying to keep it reasonably centred.

XPK sensor wiring:

Red: 4.5V-5.5V (do not connect to 12v)

Black: Ground

White: Signal out

### **Bolt fitment exploded view**

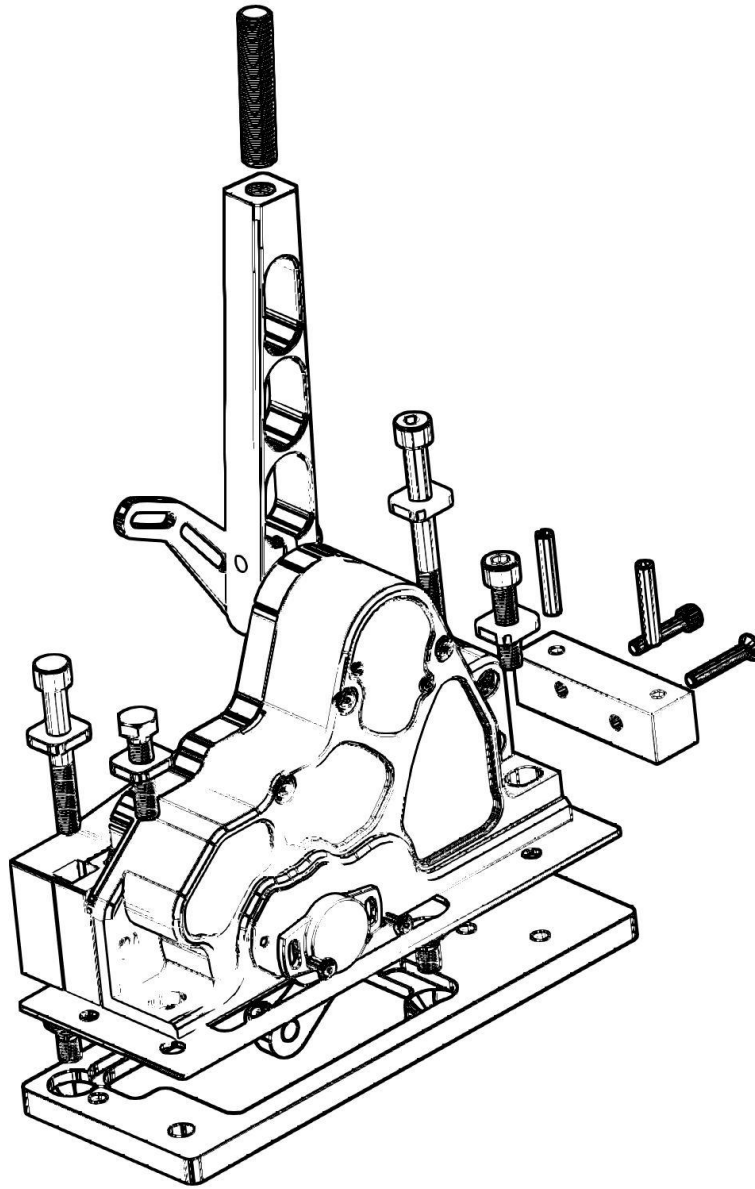

For more information please contact us at

[info@s1sequential.com](mailto:info@s1sequential.com)

[www.s1sequential.com](http://www.s1sequential.com)