



hear
TECHNOLOGIES™

hear back

talk back

extreme extender

hearbuds

cables



control your mix!™



hear
TECHNOLOGIES™

Hear Technologies is the new Pro Audio product division of Quantum Technologies Inc., a world leader in custom audio / video systems. Our mission is to offer unique and affordable solutions for personal and professional systems and support them with the industry's best customer service.

03	hear back mixer
04	hear back hub
05	talk back 200
06	talk back 600
07	extreme extenders
08	hearbuds
09	cables
09	apparel
10	wiring diagrams
19	block diagrams
22	specifications

contents

hear back mixer



Tired of someone else controlling your mix? What if you could control it yourself? **Hear Technologies** has designed a new personal monitoring system called the **hear back**. It changes the way monitor mixing is accomplished on stage or auditorium; as well as, in the studio. Imagine getting your mix exactly the way you want it. With the **hear back**, you save time and get the sound just right, the first time. This

affordable system is perfect for headphones, wired and wireless in-ear monitors, and/or conventional floor monitors.

The Hear Back System: Hub & Mixers

A basic **hear back** system consists of a Hub and personal Mixers connected using standard CAT5 cables. A single Hub supplies signal and power to a maximum of eight mixers. That's one for you and everybody in the band. If that's not enough, the Hubs can be daisy-chained using the **HearBus In** and **Out** for virtually unlimited system size. The Hub can accept analog input signals from audio mixers, auxiliary, matrix, monitor, and/or direct outputs.

The ADAT input can come from digital audio workstations, digital recorders, or digital mixers.

For front of house or remotely located digital mixers, we also have the **Extreme Extender ADAT In/Out** (pg. 7) that converts ADAT optical, which has very limited distance, to the HearBus for transmission of up to **500** feet.

Our solution, **hear back**, has several key advantages:

- Virtually unlimited system size
- Very attractive pricing
- Excellent audio fidelity
- Built-in DSP Limiter
- Very long digital lines possible without loss of audio quality
- Audio inputs ADAT, analog, and the HearBus are switch selectable from the front panel.

Mixer Features:

- Local control up to ten channels of audio
- Master volume
- Built-in DSP limiter
- 24-bit D/A converters
- Less than 1.5 millisecond total system delay
- Bus status indicator
- Headphone amplifier fault indicator
- Link indicators
- Standard CAT5 power and signal connection
- Balanced line outs, mono/stereo
- Stereo AUX in:
 - Expand numbers of mixers
 - Drum module/metronome input

- | | | | |
|----|---|----|-------------------------------------|
| 1 | Bi-Color Bus Status Indicator | 13 | Mono Channel 4 |
| 2 | Link Indicator - Channels 3/4 | 14 | Link Indicator - Channels 5/6 |
| 3 | Mono Channel 3/Stereo Link Master Level | 15 | Mono Channel 6 |
| 4 | Link Switch - Links Channels 3/4 | 16 | Link Indicator - Channels 7/8 |
| 5 | Mono Channel 5/Stereo Link Master | 17 | Mono Channel 8 |
| 6 | Link Switch - Links Channels 5/6 | 18 | Limiter Indicator |
| 7 | Mono Channel 7/Stereo Link Master | 19 | Limiter Threshold Control |
| 8 | Link Switch - Links Channels 7/8 | 20 | Master Volume |
| 9 | Stereo Mix Level Control, Channels 1/2 | 21 | Headphone Output |
| 10 | Stereo Auxiliary Input | 22 | Headphone Amplifier Fault Indicator |
| 11 | Right Line Output | 23 | Headphone Output |
| 12 | Left/Mono Line Output | | |

Specifications and description subject to change without notice. Equipment may vary from that shown in photographs.

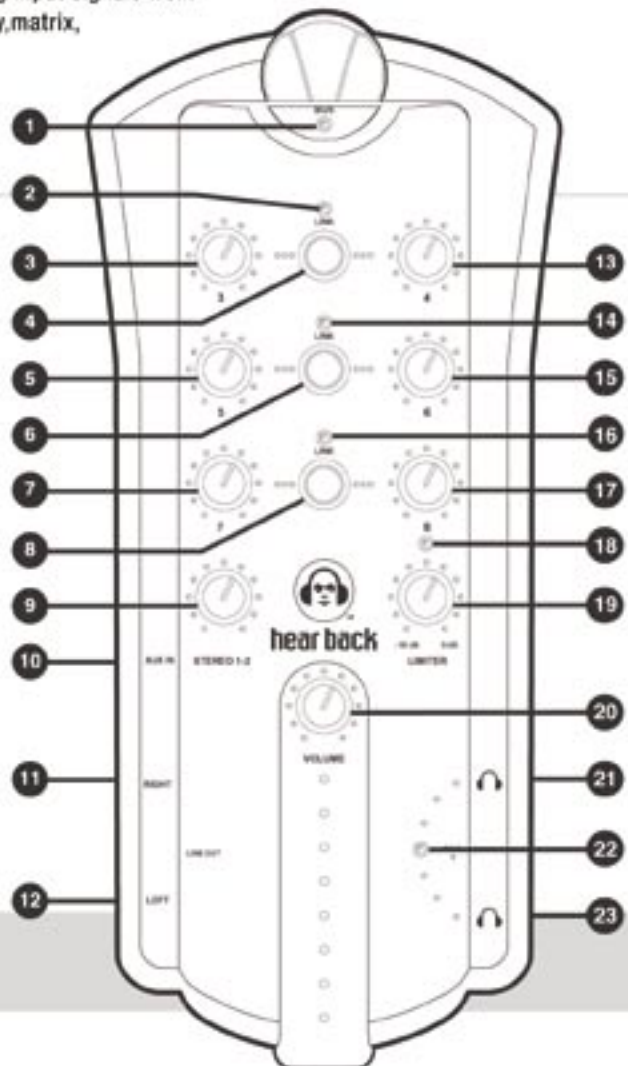



hear back hub

Hub Features:

- Local control of up to ten channels of audio (8 inputs plus a stereo Aux input). Master Volume (controls the level to the headphones, line outs and the Aux input to the line outputs)
- Built-in DSP Limiter - designed as a "brick wall" limiter for hearing protection and to protect monitor wedges from overload
- Headphone amplifier fault indicator - In case of over temperature, or a short, the red LED comes on to alert the user something is a problem.
- A second visual trouble shooting aid for the user is the Bus status indicator
- Link Indicators – Whenever two pairs of mono inputs are linked for stereo operation the link LED is illuminated
- Standard CAT5 power and signal Connection - a cost effective, simple, non-obtrusive way to connect eight channels of audio. The cable is held in place with a built-in cable strain relief.
- Balanced Line-Outs, Mono/Stereo
- Stereo AUX In
- Mixer has a built-in Mic Stand Mount and may be mounted to a standard mic stand or clipped onto a stand extension bar or clip
- High Power – Low Distortion head phone amplifiers
- Three switch selectable 8-channel input sources:
 - ADAT Optical
 - Analog
 - HearBus
- 24-bit A/D converters
- Digital inputs: 44.1KHz and 48 KHz sample rates
- Less than 1.5 milliseconds system delay
- 3-LED, four-level metering
- Standard CAT5 - delivers power and signals to mixers
- Daisy-chain for very large systems
- Internal universal input power supply
- 1 RU chassis

hear back™ system

- | | | |
|------------------------------------|----------------------|---------------------------|
| 1 Four-Level, 3-LED Input Metering | 4 AC Power Entry | 7 HearBus Output |
| 2 Input Selector Switch | 5 ADAT Optical Input | 8 Hear Back Mixer Outputs |
| 3 AC Power | 6 HearBus Input | 9 Analog Inputs |

FRONT PANEL

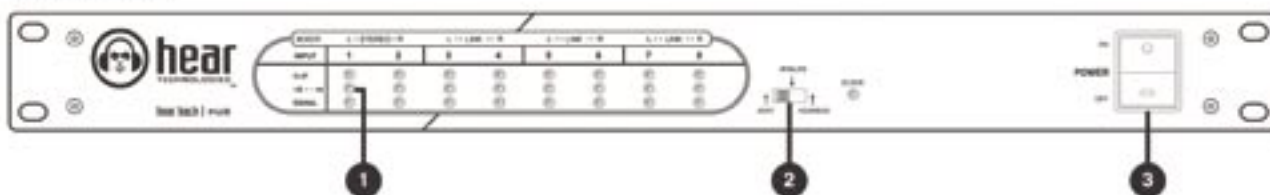

REAR PANEL

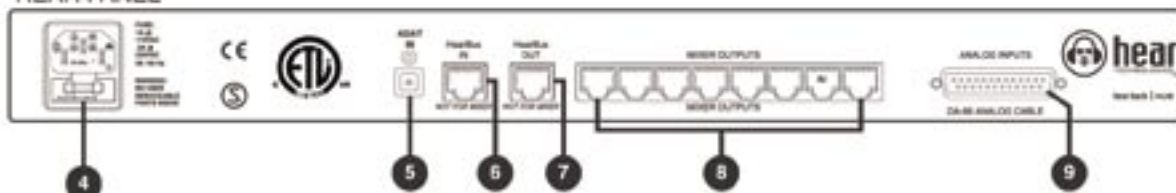

talk back 200™



200 Features:

- Talk back mic preamp with gain and level controls
- Two balanced AUX inputs and outputs
- Headphone amplifier, with MONO/STEREO switch
- Control room monitor dimming
- Wired remote control connector
- UL/CSA/CE, 100 - 230 VAC power supply
- 1 RU chassis

TALK BACK™

The **talk back** models 200 and 600 add talk back capability and control room monitor dimming to recording consoles, digital audio workstations, and portable audio workstations. Optional wired and wireless remotes (single and dual-button versions) are available for control of the talk back and/or monitor select functions. In addition to these features, the model 600 has control room monitor switching and optional wireless RF remote control. The **talk back** permits the engineer to control talk back and monitor switching from the front panel switches, the wired remotes, and the RF wireless remotes (600 only). Applications include professional recording studios, project studios, and video post-production facilities. The unit's features and audio specifications rival or surpass those found in large format recording consoles.

RC-1 / RC-2 Wired Remotes

The RC-1 and RC-2 are wired remote controls for the **talk back** 200 and **talk back** 600. All models feature a high reliability switch rated at 5 million operations.

The RC-1 (for model 600) and RC-1A (for model 200) control the **talk back** function and have a red button and a red LED indicator.

The RC-2 provides control of **talk back** and the control room monitor switching functions for the **talk back** 600. The RC-2 has a red talk back button and LED, and a blue button and blue LED for control room monitor switching. The default power-up state is with the blue LED on and "Monitor A" active.

- | | | | |
|------------------------------|---------------------------------------|------------------------------|------------------------------|
| 1 Talk Back Mic Gain | 5 Monitor Dim Control | 9 Power | 13 Left/Right Monitor Output |
| 2 Talk Back Level Control | 6 Headphone Volume Control | 10 Wired Remote | 14 Auxillary Inputs 1/2 |
| 3 Talk Back Button | 7 Headphone Stereo/Mono Select Switch | 11 Rear Panel Headphone Jack | 15 Auxillary Outputs 1/2 |
| 4 Talk Back Active Indicator | 8 Front Panel Headphone Jack | 12 Left/Right Monitor Input | 16 Mic Input |

FRONT PANEL

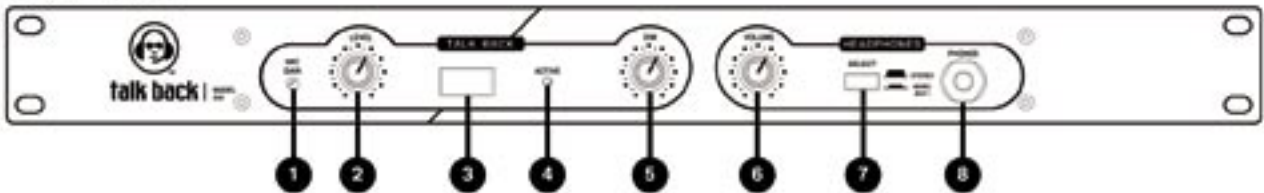

REAR PANEL

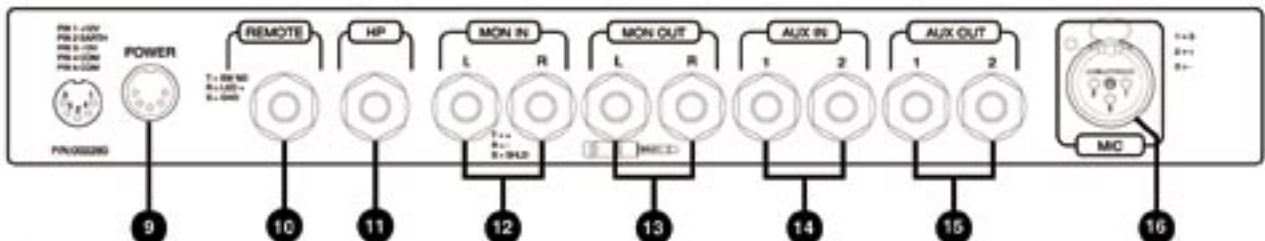



RC-1

RC-2



RF-1



RF-2

RF-1 / RF-2 Wireless Remotes

The **talk back** model RF-1 and model RF-2 are wireless RF remote controls for the **talk back** model 600. The RF-1 controls the talk back function. The RF-2 controls talk back and monitor select functions.

RF remotes may be used in conjunction with wired remotes and the front panel switches, providing flexible control for any facility.

NOTE: Multiple RF remote transmitters may be used, however, only one RF remote may be keyed at a time.

600 Features:

- Talk back mic preamp with gain and level controls
- Six balanced Aux Inputs and outputs
- A/B control room monitor switching
- Control room monitor dimming
- Wired remote control connectors
- Wireless RF "Producer Remote" (optional)
- UL/CUL/CE, 100 - 230 VAC power supply
- 1 RU chassis

talk back™ 600

- | | | | |
|------------------------------|---------------------------------|--------------------------------|--------------------------------|
| 1 Talk Back Mic Gain | 6 Monitor A Indicator | 10 Power | 14 Left/Right Monitor B Output |
| 2 Talk Back Level Control | 7 Monitor Select Button | 11 Wired Remote | 15 Auxiliary Inputs 1-6 |
| 3 Talk Back Button | 8 Monitor B Indicator | 12 Monitor Input | 16 Auxiliary Outputs 1-6 |
| 4 Talk Back Active Indicator | 9 RF Producer's Remote Receiver | 13 Left/Right Monitor A Output | 17 Mic Input |
| 5 Monitor Dim Control | | | |

FRONT PANEL

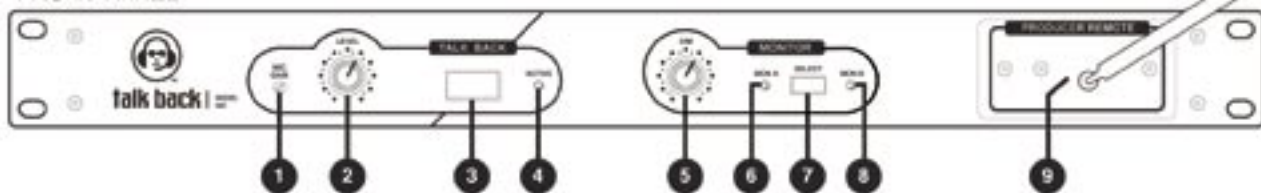

REAR PANEL

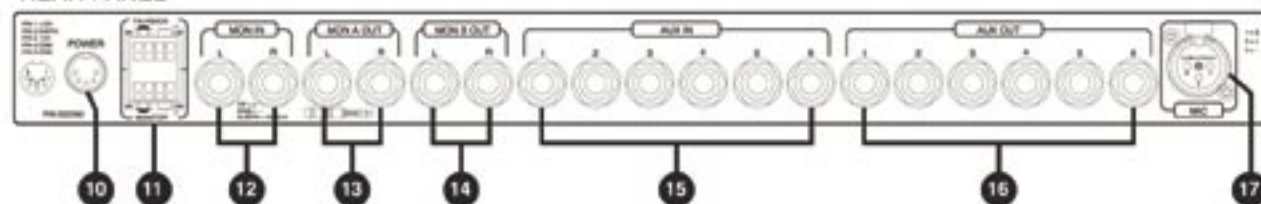



Extender Features:

- Extend ADAT® Optical cables up to 500 ft
- Uses standard CAT5 cables
- Does not affect sound quality
- Small size, durable construction
- Status LED's

Extreme Extender™ ADAT® In and Out

The units were designed to solve ADAT Optical distance limitations. The **extreme extender ADAT In** converts ADAT optical to HearBus CAT5 cable. Using CAT5, the effective length of an ADAT Optical interface can be extended up to 500 feet. This is accomplished with no loss of audio quality. The ADAT "Thru" output provides a buffered pass-thru for connection to local ADAT devices.

The **extreme extender ADAT Out** converts the CAT5 HearBus back to ADAT optical. Two parallel optical outputs provide drive for two separate ADAT devices. A bi-color clock status LED indicates the presence (green) or absence (red) of the ADAT clock.

In addition to acting as an ADAT optical extender, the **extreme extender ADAT In** may be connected to the Optical output of any ADAT device, such as a DAW, Mixer, etc. and connected to the input of a **hear back Hub**.

The **extreme extender ADAT Out** can be connected to the HearBus out of a hub to obtain two ADAT outputs.

The **extreme extender ADAT In** is powered using a small external power supply.

ADAT® is a registered trademark of Alesis Corporation.

- 1 ADAT™ Optical Input
- 2 ADAT™ Optical Thru
- 3 Power Input
- 4 HearBus™ Output
- 5 ADAT™ Optical Output
- 6 ADAT™ Optical Output
- 7 Clock LED Bi-color (Green/Red)
- 8 HearBus™ Input

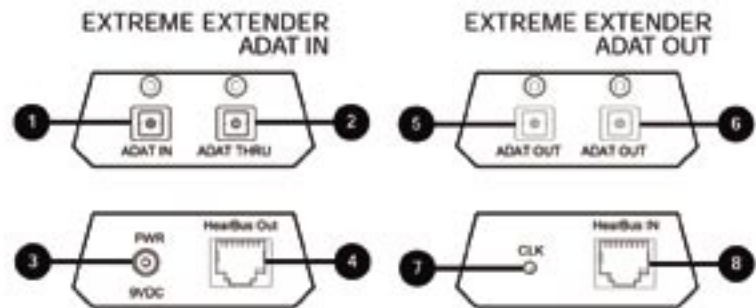

hearbud headset

hearbud

Hearbuds™ & Hearbud Headset™ Monitor

An affordable in-ear monitor headset that delivers professional performance at a great value. By creating acoustic chambers at the ear, **hearbuds** not only dramatically improve the sound of standard in-ear headphones and ear-pieces, their molded, 100% silicon, design also significantly reduces unwanted background noise levels, enabling you to enjoy the same sound clarity at lower volumes. And, because they're audiologically designed, they're comfortable to wear and won't fall out of your ears either!

Hearbud & Headset Features:

- Designed by audiologists
- Better sound quality at lower volumes
- Can be used on stage and in the studio
- Great for hear back, MP3 players, cell-phones, and other personal audio
- Hearbuds alone fit most in-ear headsets
- Works great in noisy environments because they block unwanted sounds
- Three sizes of hearbuds included in each package
- Comfortable, safe, and secure
- Washable

hearbuds™

How to use hearbuds.



1

First, familiarize yourself with the differences between the hearbud shapes: Left (L), Right (R), Back, and Front (indicated by a raised spot next to the R or L symbol).



2

Before fitting to your in-ear earpieces, experiment with each of the three sizes: 1, 2 or 3. Try them in each ear to find the best fit. It may be that your left and right ear fit different sizes. Remember, the raised spot always faces forward.



3

The hearbuds plugs should feel snug and secure without feeling too tight. Make sure you have them inserted correctly for comfort and performance.



4

Now take them off and push the open ends of your two chosen Left and Right hearbuds™ plugs over the corresponding earpiece.



5

Turn down the master volume on your hearback or music source, put the earpieces in your ears and adjust the volume to the desired level. You'll notice the difference immediately. (To remove, gently peel hearbuds from earpiece).

Quality cables that work with your hear back system

CAT5E cables are available in 2, 12, 25, 50 and 100 foot lengths.



CAT5E

Optical Cables are available in 6, 12, and 25 foot lengths.



OPTICAL

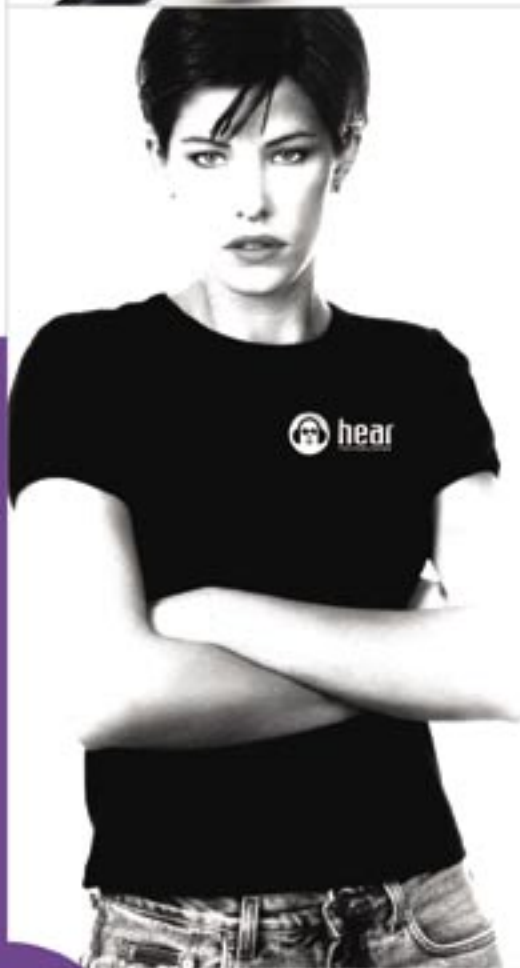

T-shirts and Polo's

Extreme comfort.
100% cotton premium
quality apparel.

S

M

L

XL

XXL



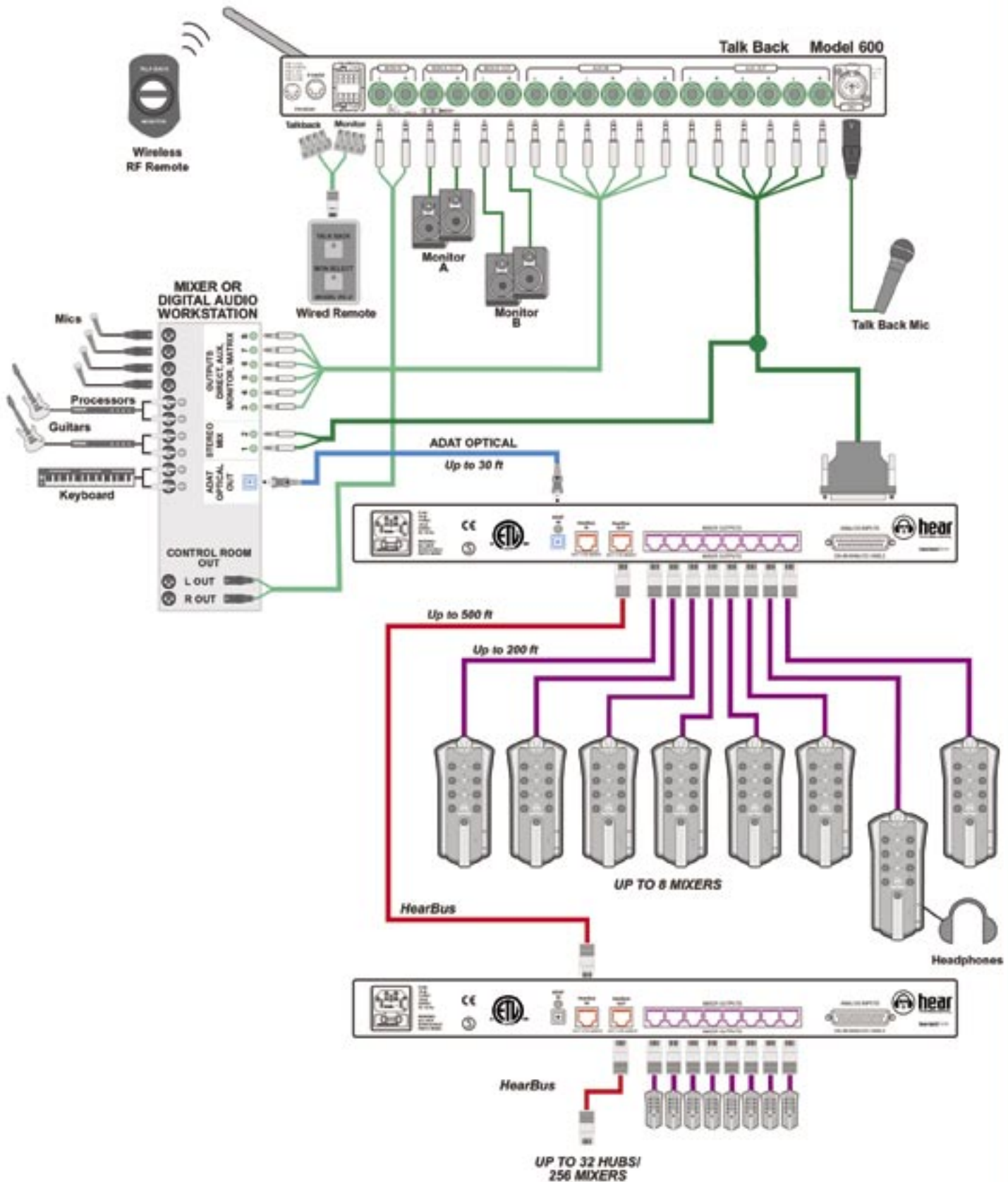

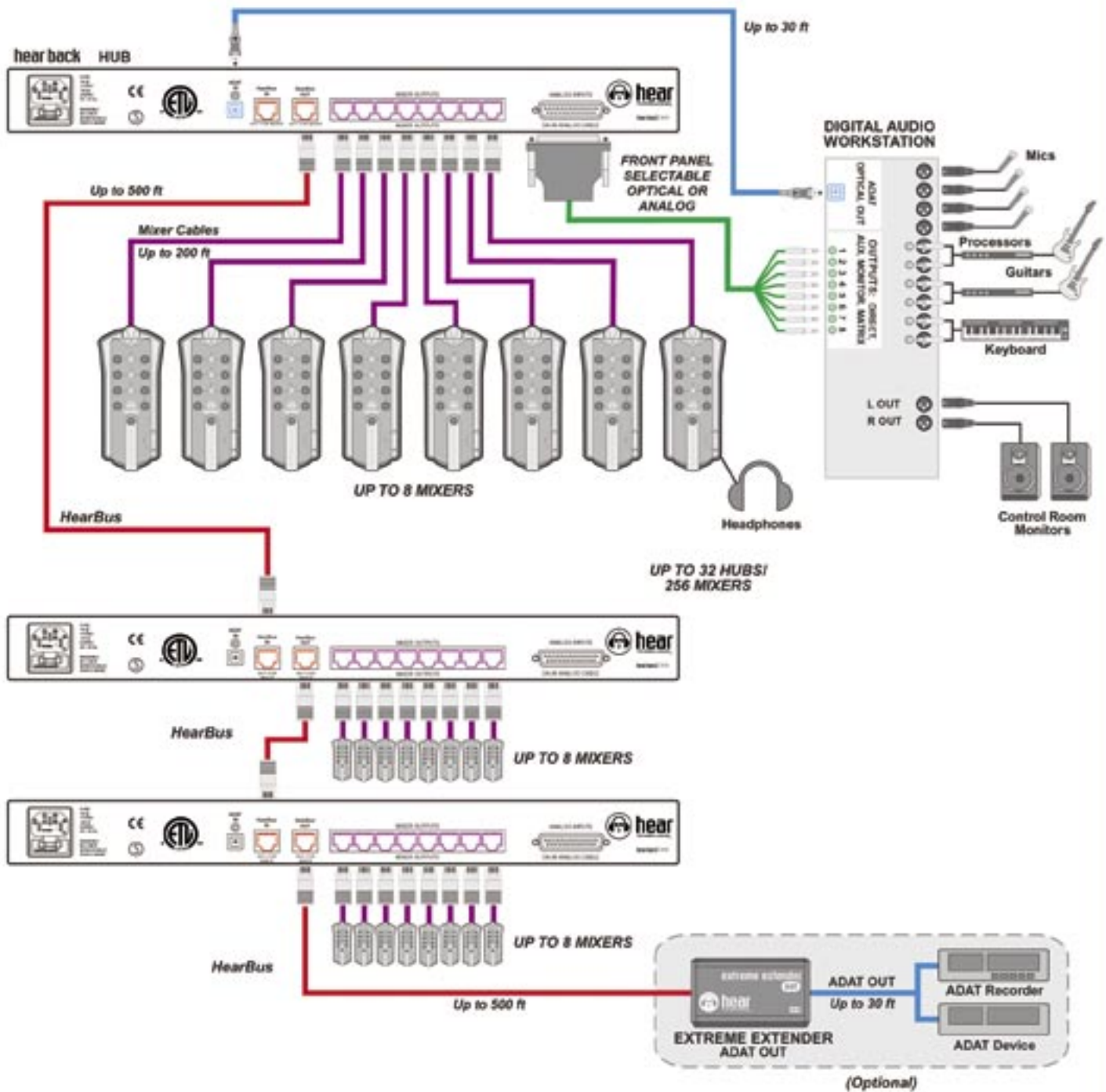

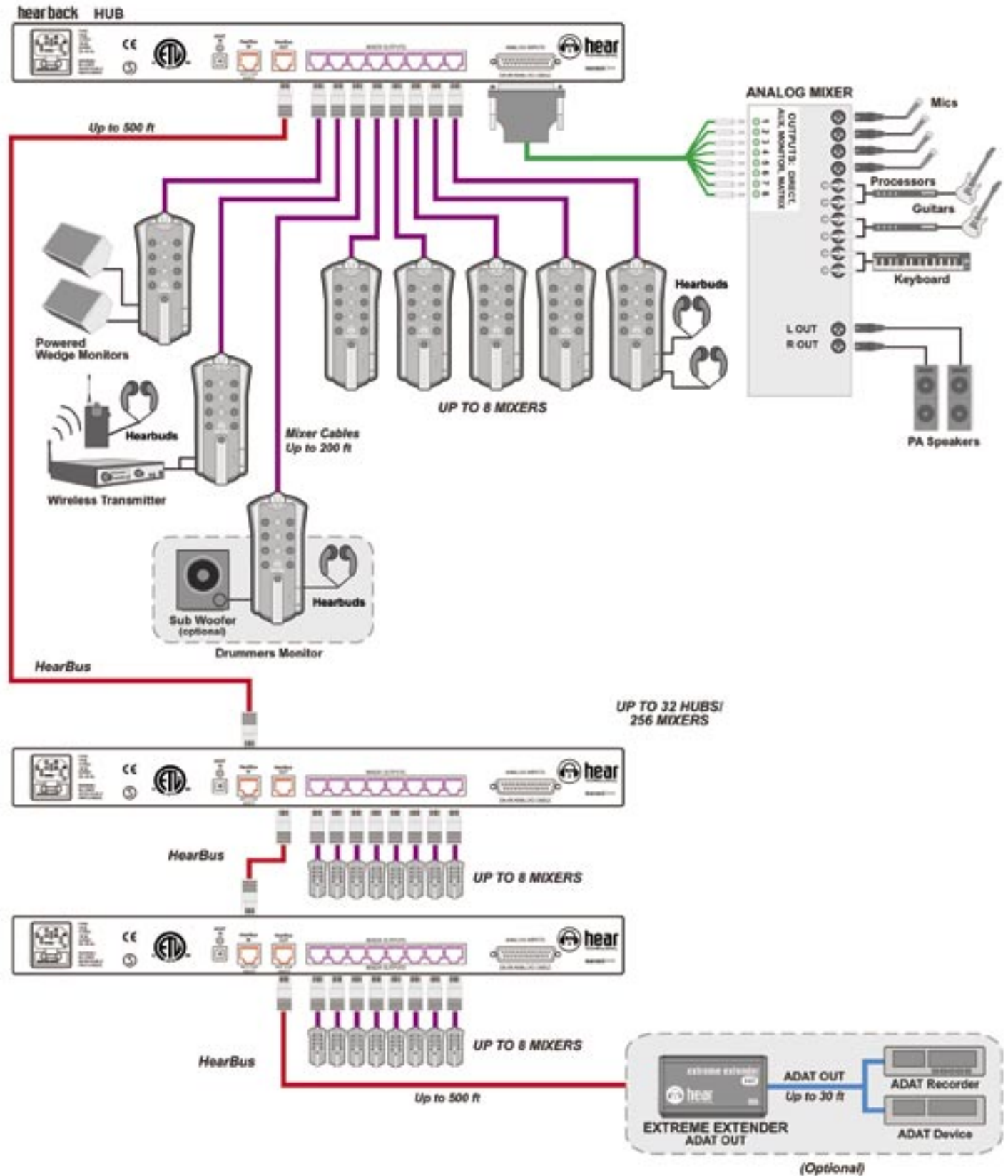

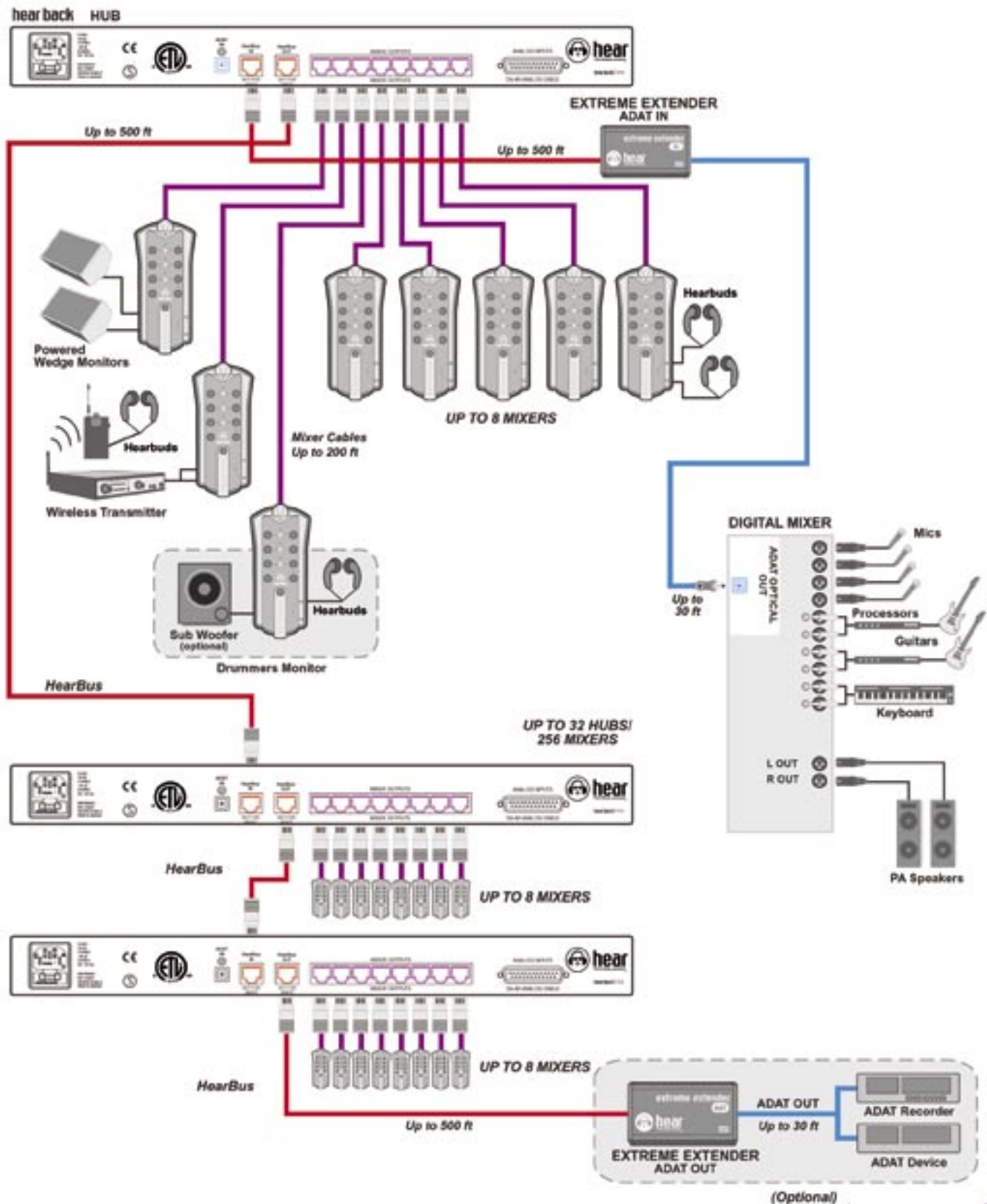

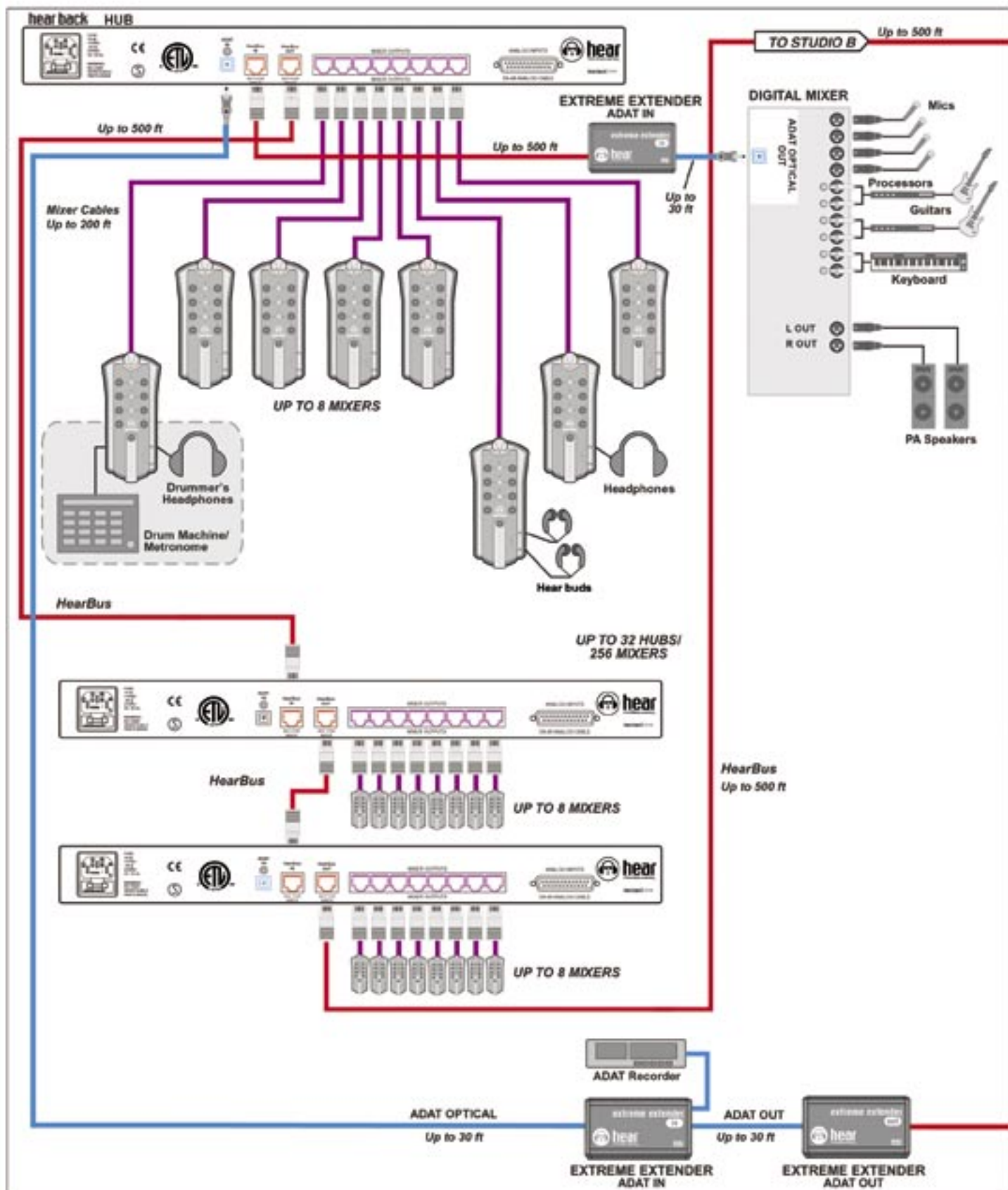

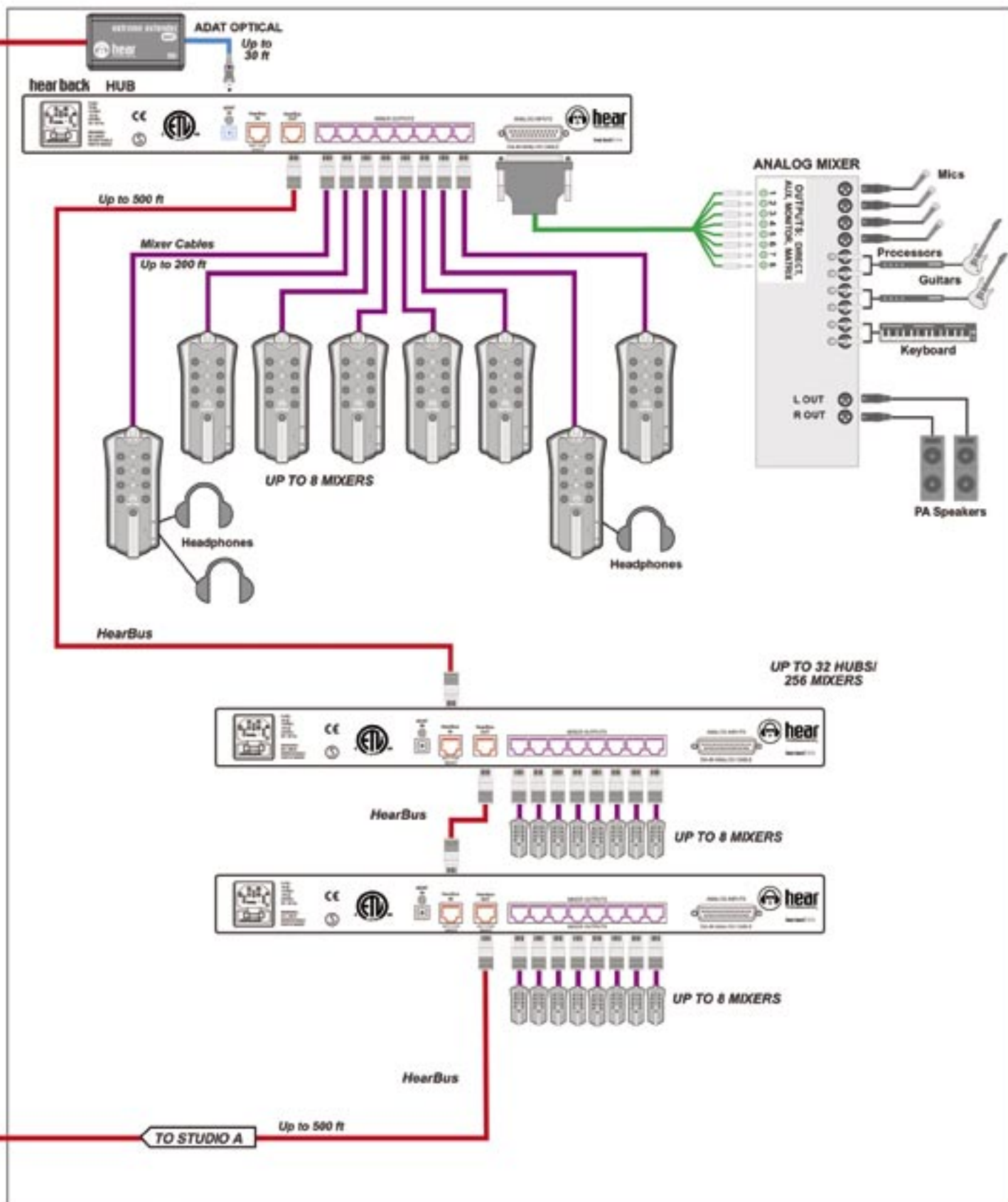

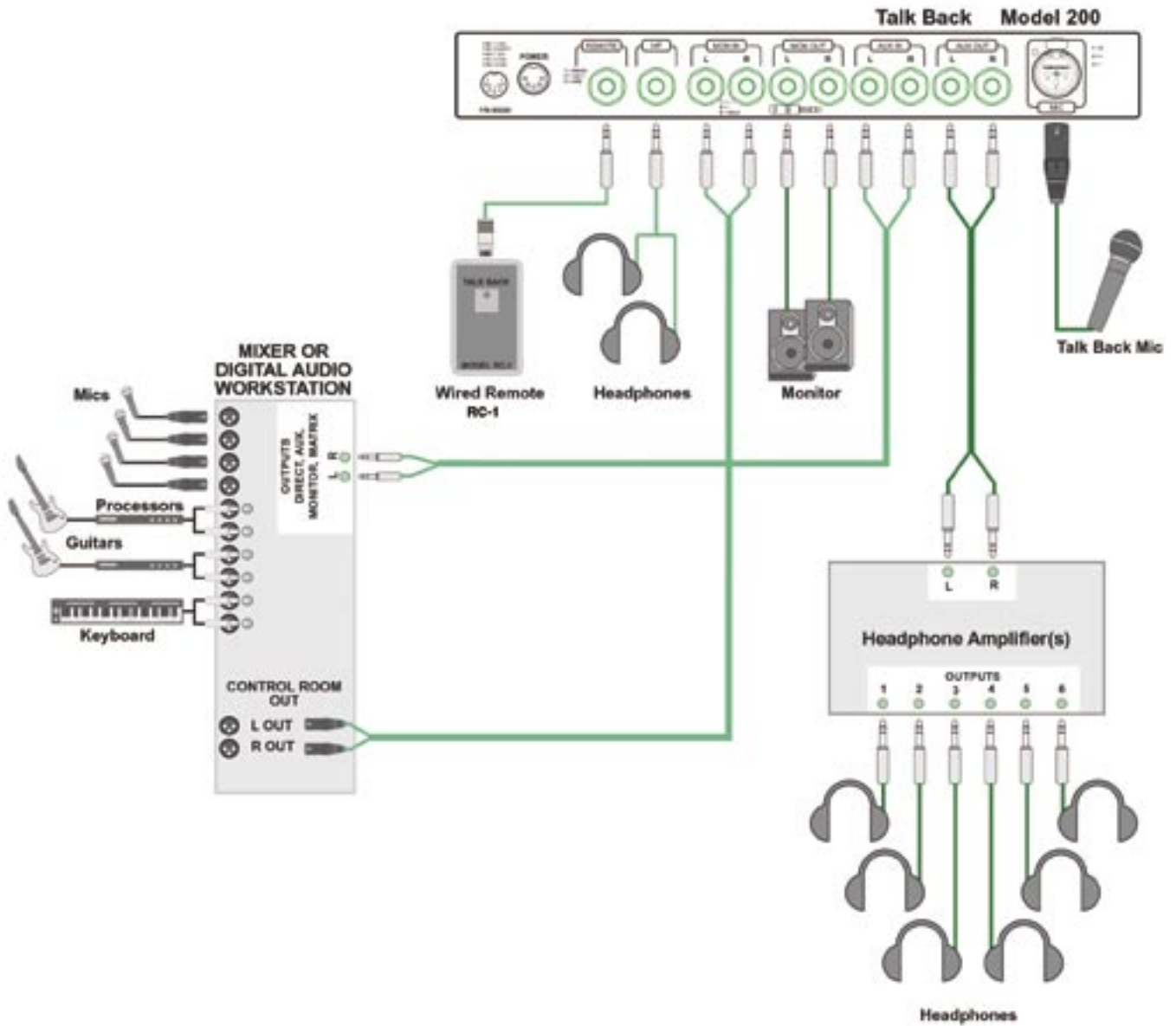

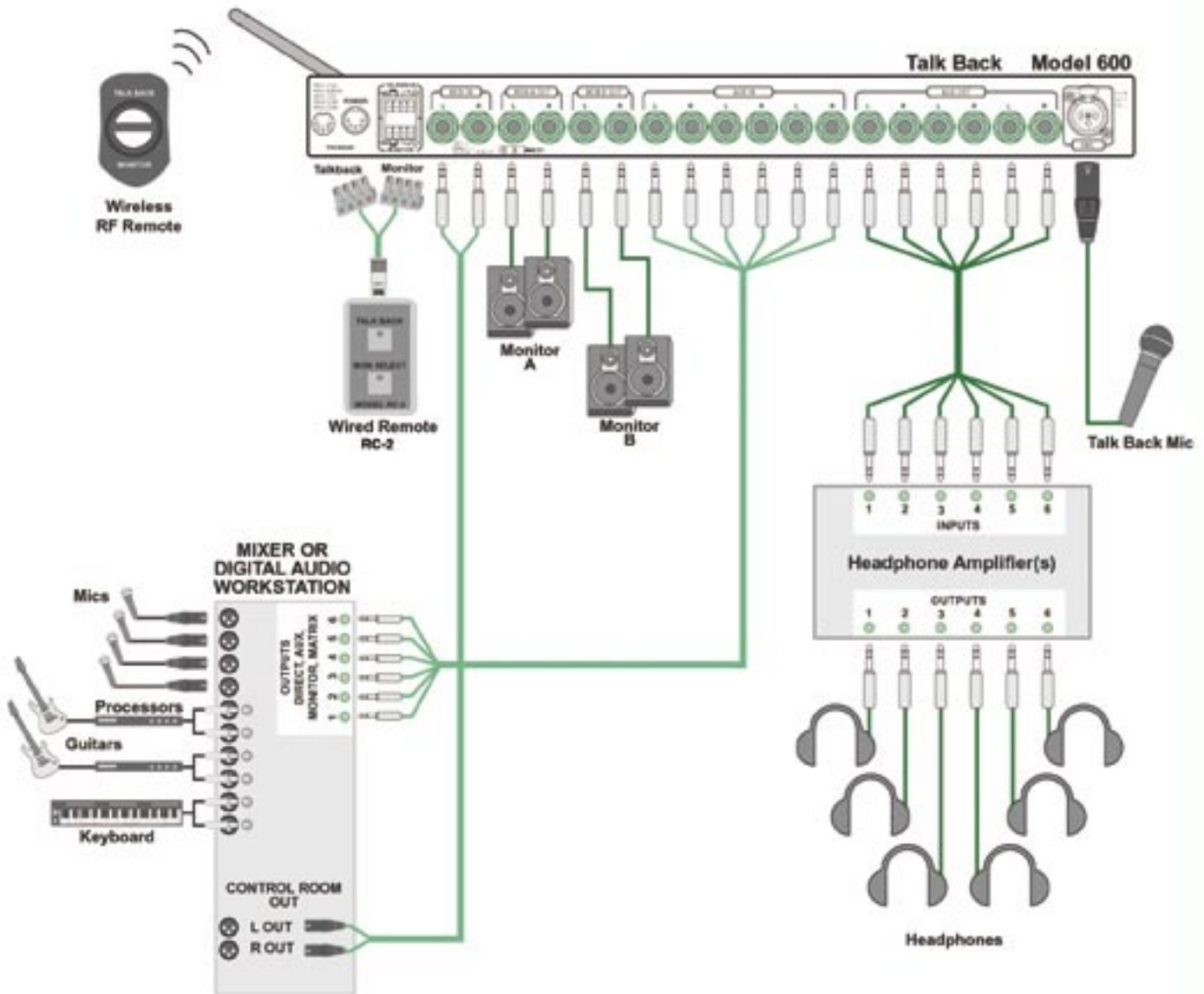

talk back 200

TALK BACK 200

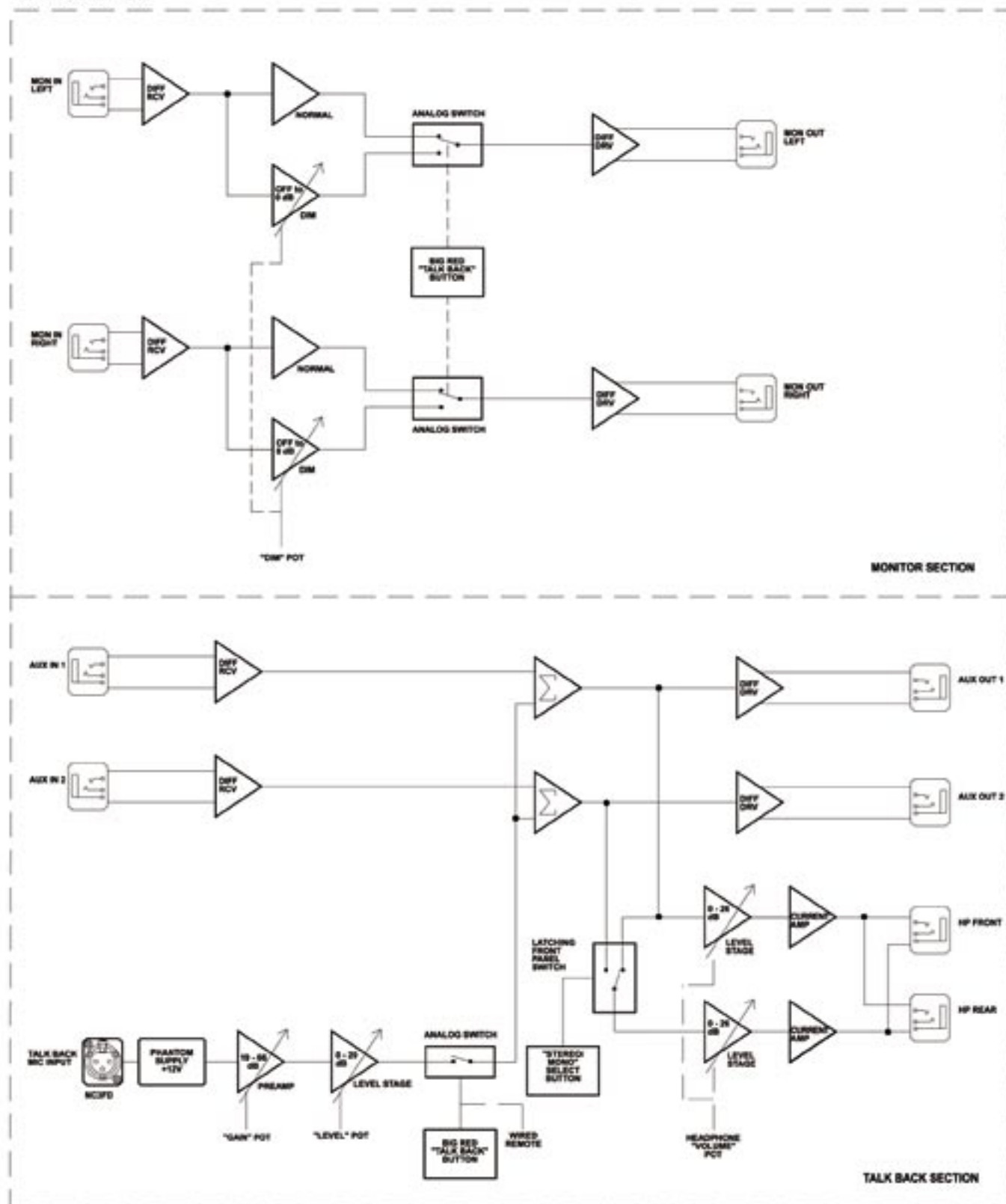

TALK BACK 600

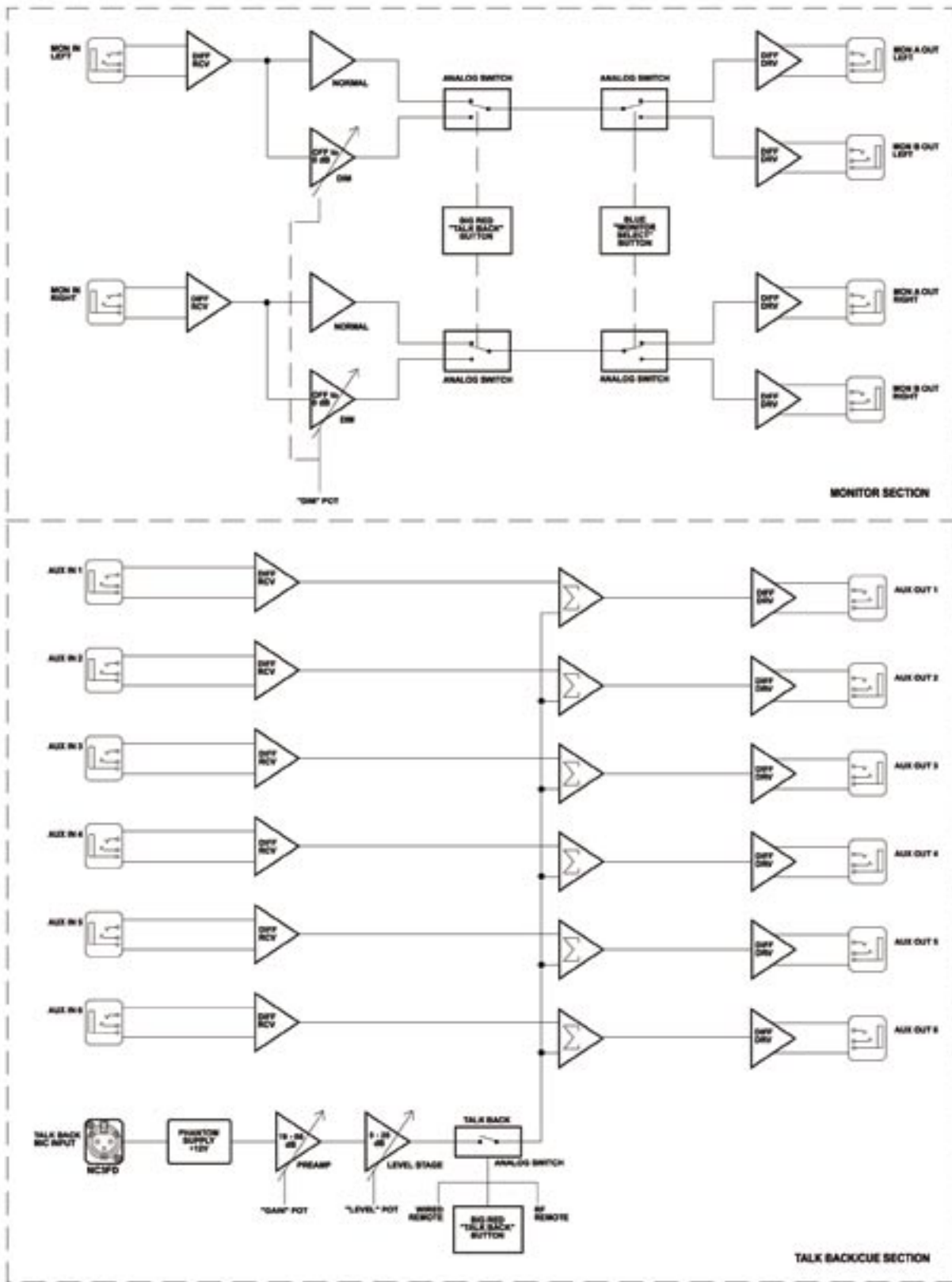

hear back & extreme extenders

block diagram

HEAR BACK MIXER

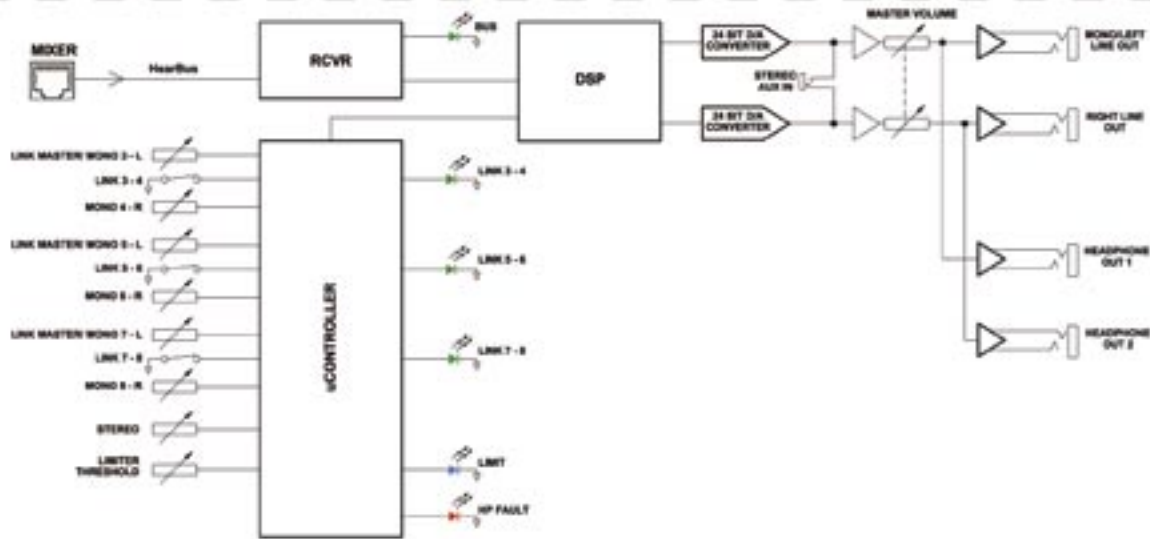

HEAR BACK HUB

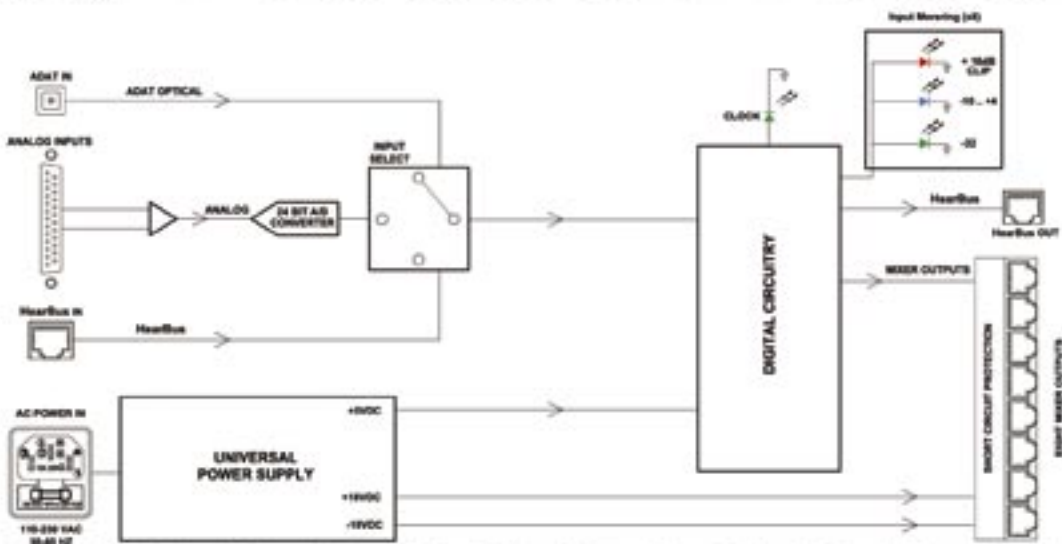

EXTREME EXTENDER ADAT IN

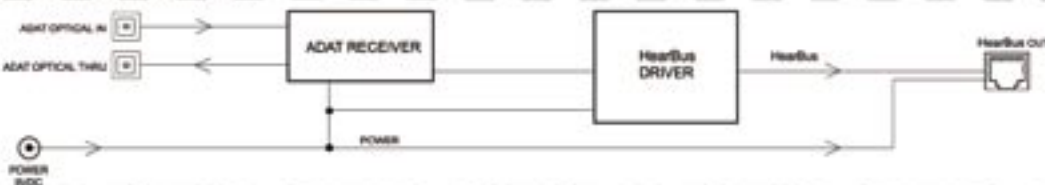

EXTREME EXTENDER ADAT OUT

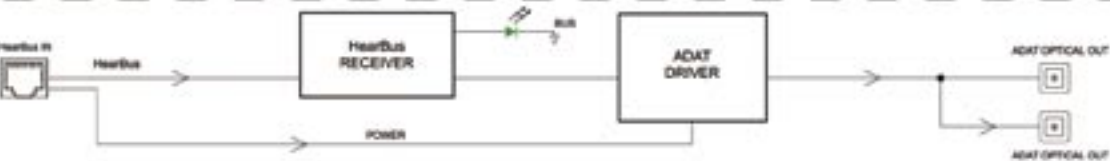

0 dBu = 0.775 Vrms	Hear Back System (Hub and Mixer)	Extreme Extender ADAT In/Out	Talk Back 200	Talk Back 600
Line Inputs/Outputs				
Frequency Response	20 to 20KHz, +0.1/ -0.5	---	10 Hz to 25KHz, + 0.1/ -0.3 dBu	10 Hz to 25KHz, + 0.1/ -0.3 dBu
THD+N	< 0.01% @ 1KHz, < 0.005 @ 20KHz	---	0.004% 20 - 20 KHz @ +4dBu	0.0025% 20 - 20 KHz @ +4dBu
IMD - 60Hz/ 7KHz	< 0.018% @ +4dBu	---	0.008% @ +4dBu	0.004% @ +4dBu
Total Propagation Delay	< 1.5 millisecond	---	---	---
Crosstalk	-97dBu @ 1KHz at +18dBu	---	-90 dBu, typical	-90 dBu, typical
Dynamic Range	> 112dBu typical	---	---	---
Noise, A weighted	> -91dBu analog, -97dBu Optical	---	---	---
Max Input Level	+15dBu	---	+24dBu	+24dBu
Max Output Level into 10K	---	---	+24dBu	+24dBu
Head Phone Outputs				
Frequency Response	20 to 20KHz, +0.03 / -0.4	---	---	---
THD+N @ 150mW (16 thru 600 Ohms)	---	---	0.005% 20 - 20 KHz, 150 Ohms	---
IMD @ 150mW	< 0.018% typical, 60Hz / 7KHz	---	---	---
Power at 0.5% THD	---	---	---	---
- 16 Ohm	700 milliwatts	---	---	---
- 47 Ohm	2 watts	---	---	---
- 600 Ohm	220 milliwatts	---	---	---
Max Power, 32 - 150 Ohms (200 only)	---	---	180 milliwatts	---
Impedance Range	16 - 600 Ohms	---	32 to 600 Ohms	---
Mic Input				
Gain	---	---	19 to 86dBu, +/- 2dB	19 to 86dBu, +/- 2dB
Phantom Power	---	---	12 VDC	12 VDC
THD+N	---	---	0.05%, 20-20K	0.05%, 20-20K
Frequency Response	---	---	125Hz to 25KHz	125Hz to 25KHz
Physical				
Weight	5.0 lbs	5.4 oz	2.5 lbs	3.75 lbs
Dimensions	(see below)	1.15" H x 2.6" W x 6.25" D	1.75" H x 19" W x 6.5" D	1.75" H x 19" W x 6.5" D
- Mixer	11.5" H x 5.2" W x 3.6" D	---	---	---
- Hub	1.75" H x 19" W x 7.125" D	---	---	---
Power				
Requirements	100-230VAC, 50/60HZ, 60 Watts	9 VDC, 120 mA	100-230VAC, 50/60HZ, 60 Watts	100-230VAC, 50/60HZ, 60 Watts

Note: Specifications and features subject to change without notice.
Detailed specifications may be found online at www.heartechnologies.com.



HEAR TECHNOLOGIES™

991 Discovery Drive

Huntsville, AL 35806

Phone: 256.922.1200

Fax: 256.922.1221

www.heartechnologies.com

