

1.0" WIDE X 1/8" THICK
SS TYPE 317 HANDLE

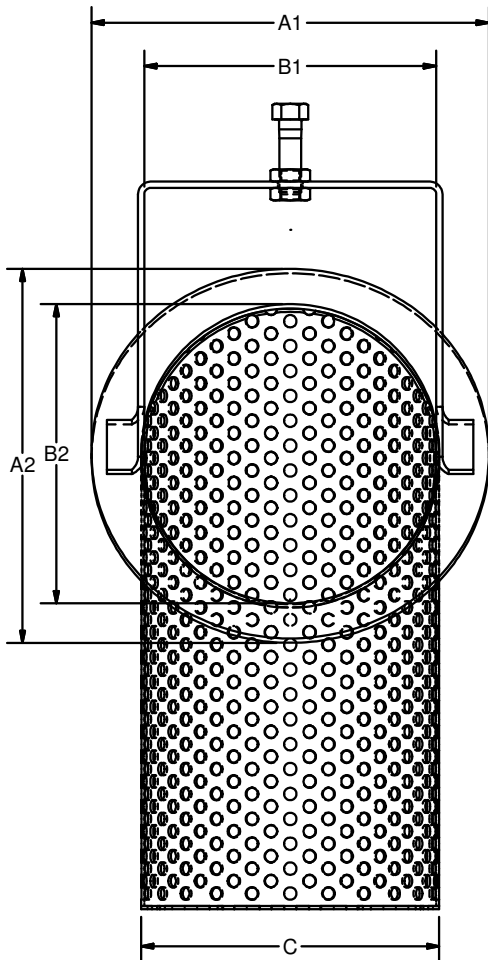

SS TYPE 317 BOLT

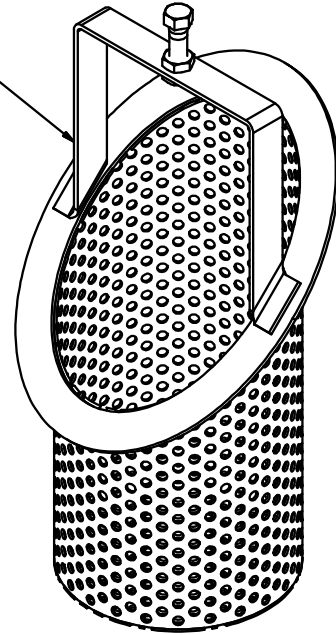
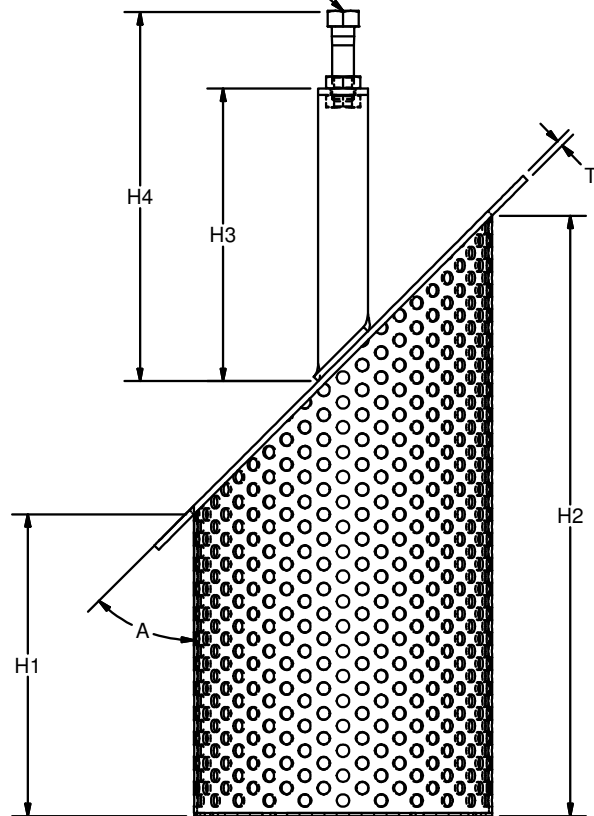

DWG # SLANT BSKT SQ
ADJUST

NOTE:
THIS DRAWING CONTAINS INFORMATION PROPRIETARY TO
WWW.STRAINERBASKETS.COM. THIS DRAWING MAY NOT BE
REPRODUCED WITHOUT THE EXPRESS WRITTEN PERMISSION
OF WWW.STRAINERBASKETS.COM.

REVISION NO.	ECN NO.	BY:	DATE:	APPD:
REV. DESC:				
WWW.STRAINERBASKETS.COM				
SLANTED BASKET WITH ADJUSTABLE SQUARE HANDLE				
DESIGNED BY		PRODUCT LINE		SHEET 1 OF 1
DWN BY JOHN CAMP		DATE 111319		DWG NO.
APPD ENG		PLOT SIZE 12.5		REV.
SLANT BSKT SQ ADJUST				