



**CLEANERS & DEGREASERS**



**LUBRICANTS, GREASES & OILS**



**ANTI-CORROSION**



**METAL WORKING**



**WELDING**



**PAINTS**



**POLYMER PROCESSING**

# Ambersil

**Product Range**

Since 1948

ISSUE 9

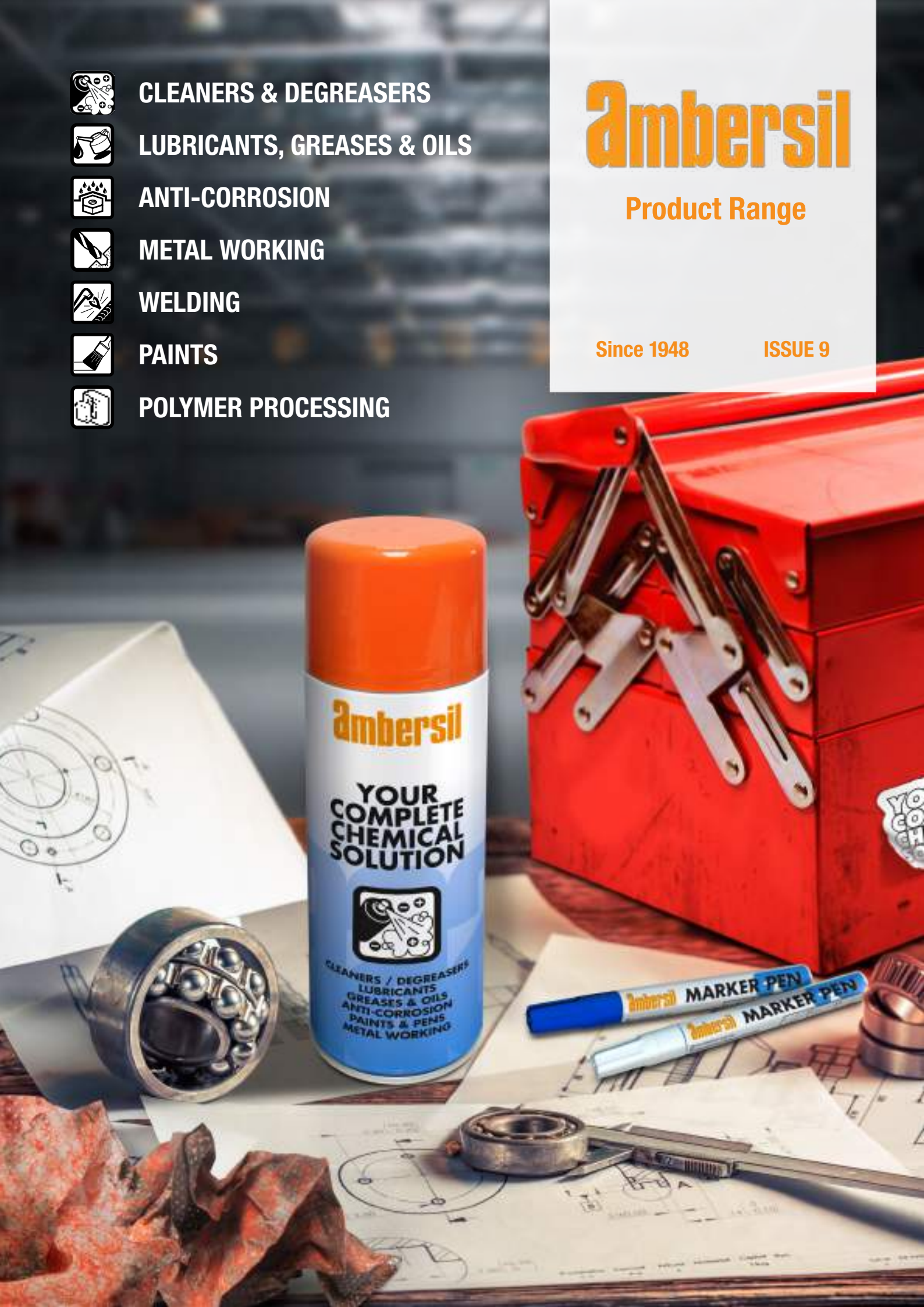

# CONTENTS BY SECTION

## CLEANERS & DEGREASERS

Amberclens	14
Amberclens FG	14
Ambersolv / AB1	14
Degreaser RTU	14
Degreaser FG	15
Stainless Steel Cleaner FG	15
Sugar Remover & Inhibitor FG	15
Citrus Cleaner & Degreaser	15
Hard Surface Cleaner	16
Traffic Film Remover	16
DP17	16
Terrazzo Cleaner	16
White Spirit	17
SBP 11	17
Hand Cleaner Plus	17
Tough Wipes	18
Hand Cleaning Wipes	18
Hard Surface Sanitising Wipes FG	18
Engineers Wipes	18
Amberklene FE10	19
Amberklene ME20	19
Amberklene LO30	19
Brake Cleaner	19
Industrial Degreaser FG	20
Solvent Cleaner FG	20
Solvent Degreaser	20
Amberklene FG	20
Lec-Klene	21
Ambersolv SB1	21
Fast Clean 200/201	21
BA40 Solvent	21
Paint & Graffiti Remover	22
Gasket Stripper GS5	22
Multi-Surface Polish	22
Glass Cleaner	22
Air Duster /2	23
Invertible Air Duster /2	23
Duster One	23
Dust Remover	23
Anti-Static Spray	24
Universal Screen Cleaner	24
Label Remover	24
Label & Adhesive Remover FG	24
Ambertron	25
NF Precision Cleaner	25
Contact Cleaner FG	25
IPA Solvent	26
PCB Cleaner	26
Flux Remover	26
CCL 100	26
Ultrasonic Cleaning Fluid	27
Acrylic Conformal Coating	27
SV100	27
Freezer /2	27

## LUBRICANTS

40+	30
AGL 1	30
PX24	30
Moisture Remover FG	30
Machine Oil FG	31
Multi-Lube	31
Penetrating Oil	31
Penetrating Oil FG	31
Rust Flash	32
Silicone Lubricant	32
Silicone Anti-Stick	32
Silicone FG	32
Amberglide	33
Dry Film Anti-Stick	33
Dry PTFE Lube FG	33
Dry Moly	33
Copper Anti-Seize Paste	34
Assembly Paste FG	34
Gear & Wire Rope Lubricant	34
Chainspray	34
Chain Lube FG	35
High Temperature Lubricating Oil FG	35
Wire Rope Lubricant	35
Belt Dressing FG	35
Blue Adhesive Lubricant	36
Graphite Release Spray	36
Graphite Lock Lube	36
Ambergrease EXL	36
Ambergrease FG1	37
Ambergrease FG2	37
Ambergrease FG3	37
Ambergrease FG4	37
Hi-Load Lube FG	38
Food Grease FG	38
White Spray Grease	38
Ambergrease SIL	38
AMS4 Silicone Grease	39
3H Oil FG	39
Silicone Oil	39
Hydraulic Oil Super 32/46/68 FG	40
Gear Oil Super 150/220/320 FG	40
Multi Oil 32/46 FG	41
Lubricating Oil 'LO' 32/68/100	41

## METAL WORKING

Tufcut Liquid	43
Tufcut Spray	43
Tufcut Foam	43
Tufcut Compound	43
Tufcut Aqua	43
Spatter Release	44
Bioweld	44
Easy Weld	44
Leak Detector	44
Flaw Detector Cleaner 1	45
Flaw Detector Penetrant 2	45
Flaw Detector Developer 3	45

## ANTI-CORROSION / PAINTS

Acrylic Paint	47
Cold Galvanise	48
Bright, Cold Galvanise	48
Galvanising Zinc Rich	48
Galva Shine	48
Corrosion Inhibitor	49
Battery Terminal Protector	49
Alu Hi-Temp	49
Inox 200	49
Zinc Primer	50
Rust Converter	50
Galva Colour	50
Marker Pen	51
Aqua Marker Pen	51

## ADHESIVES / SEALANTS

Adhesive HS300	52
Adhesive MP100	52
Adhesive NC500	52
Adhesive QS900	52
5024A Silicone Adhesive Sealant	53
5005A Silicone Adhesive Sealant	53
High Temperature Gasket Sealant	53

## POLYMER PROCESSING

### Silicone Release Agents

Formula 6	56
Formula 1	56
Formula 2	56
Formula 8	56
Formula 20	57
Silicone Release FG	57
HD-Sil Release	57
PUR 400	57

### Non-Silicone Release Agents

Formula 5	58
Formula 4	58
Formula 7	58
Formula 10	58
Formula 11	59
Non-Silicone Release FG	59
Formula 12	59
Formula 14	59
No-Sil Release	60

### Other Release Agents

Release 100	60
DP200	60
MPR 100	60
MPR 200	61
COM 300	61
COM 400	61
PUR 101	61
PUR 300	62
ROM 300	62
RBR 100	62
RBR 310	62

### Anti-Corrosion & Misc. Cleaning

Ejector Pin Lubricant	63
Mould Protective	63
Green Mould Protective	63
Blue Mould Protective	63
Tool Guard	64
Clear Mould Protective	64
Polymer Remover	64
Polyklene R	64
Mould Cleaner	65
Solvent Cleaner FG	65
Polyester Mould Cleaner	65
Mould Solv	65

## key code



Available in 5 Litres



Available in 25 Litres



Available in 200 Litres



Available in 12.5 Kg



Available in 100g



Available in 200ml



Available in 350ml



Trigger Spray



Available in 400g



Available in Cartridge



Available in 30 Wipes



High Temp Resistant



Non-Flammable



MOD Approval



Aerospace Approval



Rail Approval



Automotive Approval



Bio-degradable



360° Spray System



NSF Registered



6 Multi-Language



25 Multi-Language

# CONTENTS BY INDUSTRY

## INDUSTRIAL MRO CLEANERS

Amberclens	14
Amberklene FE10	19
Amberklene LO30	19
Amberklene ME20	19
Ambersolv / AB1	14
Ambersolv SB1	21
Citrus Cleaner & Degreaser	15
Degreaser RTU	15
Hard Surface Cleaner	16
Traffic Film Remover	16
Fast Clean 200/201	21
Paint & Graffiti Remover	22

## LUBRICANTS

40+	30
AGL 1	30
AMS4 Silicone Grease	39
Amberglide	33
Ambergrease EXL	36
Ambergrease SIL	38
Chainspray	34
Copper Anti-Seize Paste	34
Silicone Lubricant	32
Silicone Oil	39
Penetrating Oil	31
PX24	30
Rust Flash	32
Silicone Anti-Stick	32
Dry Film Anti-Stick	33
Dry Moly	33
Gear and Wire Rope Lubricant	34
Wire Rope Lubricant	35

## METAL WORKING

Bioweld	44
Easy Weld	44
Spatter Release	44
Flaw Detector Cleaner 1	45
Flaw Detector Penetrant 2	45
Flaw Detector Developer 3	45
Leak Detector	44
Marker Pens	51
Aqua Marker Pens	51
Tufcut Aqua	43
Tufcut Compound	43
Tufcut Foam	43
Tufcut Liquid	43
Tufcut Spray	43

## ANTI-CORROSION

Cold Galvanise	48
Bright, Cold Galvanise	48
Corrosion Inhibitor	49
Acrylic Paint	47
Galva Colour	50
Galva Shine	48
Galvanising Zinc Rich	48
Inox 200	49
Alu Hi-Temp	49
Rust Converter	50
Zinc Primer	50
Battery Terminal Protector	49

## ADHESIVES

Adhesive HS300	52
Adhesive MP100	52
Adhesive NC500	52
Adhesive QS900	52
5005A Silicone Adhesive Sealant	53
5024A Silicone Adhesive Sealant	53
High Temperature Gasket Sealant	53

## HYGIENE & FACILITIES MANAGEMENT CLEANERS

Universal Screen Cleaner	24
Label Remover	24
Glass Cleaner	22
Hand Cleaner Plus	17
Stainless Steel Cleaner FG	15
Multi-Surface Spray Polish	22
Paint & Graffiti Remover	22
Engineers Wipes	18
Hand Cleaning Wipes	18
Tough Wipes	18
Citrus Cleaner & Degreaser	15
Degreaser RTU	14
Hard Surface Cleaner	16
Hard Surface Sanitising Wipes FG	18
Traffic Film Remover	16

## ELECTRICAL SERVICING CLEANERS

Air Duster /2	23
Invertible Air Duster /2	23
Duster One	23
Dust Remover	23
Ambertron	25
IPA Solvent	26
Flux Remover	26
Anti-Static Spray	24
Lec-Klene	21
NF Precision Cleaner	25
PCB Cleaner	26
Ultrasonic Cleaning Fluid	27
Universal Screen Cleaner	24
Freezer /2	27
CCL100	26

## LUBRICANTS

AMS4	39
Ambergrease Sil	38

## ANTI-CORROSION

SV 100	27
Acrylic Conformal Coating	27

## FOOD & BEVERAGE CLEANERS

Amberclens FG	14
Degreaser FG	15
Amberklene FG	20
Industrial Degreaser FG	20
Contact Cleaner FG	25
Air Duster /2	23
Label & Adhesive Remover FG	24
Stainless Steel Cleaner FG	15
Sugar Remover & Inhibitor FG	15
Solvent Cleaner FG	20
Hard Surface Sanitising Wipes FG	18

## LUBRICANTS

Machine Oil FG	31
Moisture Remover FG	30
Silicone FG	32
Belt Dressing FG	35
Chain Lube FG	35
High Temperature Lubricating Oil FG	35
Food Grease FG	38
Penetrating Oil FG	31
Dry PTFE Lube FG	33
Silicone Release FG	57
Non-Silicone Release FG	59

## GREASES

Ambergrease FG1	37
Ambergrease FG2	37
Ambergrease FG3	37
Ambergrease FG4	37
Hi-Load Lube FG	38
Assembly Paste FG	34

## FOOD / BEVERAGE / PHARMA OILS

Gear Oil Super 150 FG	40
Gear Oil Super 220 FG	40
Gear Oil Super 320 FG	40
Hydraulic Oil Super 32 FG	40
Hydraulic Oil Super 46 FG	40
Hydraulic Oil Super 68 FG	40
Multi Oil 32 FG	41
Multi Oil 46 FG	41
Lubricating Oils 'LO'	41

## RAIL / MASS TRANSIT / FLT CLEANERS

Brake Cleaner	19
DP17	16
SBP11	17
Solvent Degreaser	20
Gasket Stripper GS5	22
White Spirit	17
Terrazzo Cleaner	16

## LUBRICANTS

AMS4	39
FLT Chainlube	34
Multi-Lube	31
ROM 300 Pantograph Protector	62
White Spray Grease	38

## MOULDING OPERATIONS CLEANERS

Polyester Mould Cleaner	65
Polymer Remover	64
Mould Cleaner	65
Mould Solv	65
Polyklene R	64
Solvent Cleaner FG	65

## SILICONE RELEASE AGENTS

Formula 6	56
Release 100	60
Formula 1	56
Formula 2	56
Formula 8	56
Formula 20	57
PUR 400	57
HD-Silicone Release	57
Silicone Release FG	57

## NON-SILICONE RELEASE AGENTS

Formula 11	59
Formula 5	58
Formula 4	58
Formula 14	59
Formula 7	58
Formula 10	58
Formula 12	59
No-Sil Release	60
Non-Silicone Release FG	59

## OTHER RELEASE AGENTS

ROM 300 Pantograph Protector	62
COM 300	61
COM 400	61
DP200	60
MPR 100	60
MPR 200	61
PUR 101	61
PUR 300	62
RBR 100	62
RBR 310	62

## ANTI-CORROSION

Clear Mould Protective	64
Green Mould Protective	63
Mould Protective	63
Tool Guard	64
Blue Mould Protective FG	63

## Misrepresentation Act 1967 & Trade Descriptions Act 1968

The information given in this publication is based on our experience and reports from customers. There are many factors outside our control and knowledge which affect the use and performance of our products and for which reason no warranty is given, express or implied. Users should make their own tests to determine the applicability of such information or the suitability of any products for their own particular purposes. Statements concerning the use of the products described herein are not to be construed as recommending the infringement of any patent and no liability for infringement arising out of any such use is to be assumed.

All images used are for representation only. Colour swatches are not identical match to actual colour.

# ABOUT AMBERSIL



## WHO WE ARE

- Ambersil is the market leading brand of CRC Industries UK Ltd
- CRC UK is part of the global CRC Industries group
- We have over 60 years experience manufacturing and marketing Ambersil products

## WHAT WE DO

- We are a market leading formulator and manufacturer of MRO chemicals, developed for industrial applications
- We work cooperatively with industry to deliver true added value
- We are specialists in aerosol technology with a purpose built blending and production facility

## HOW WE DO IT

- We have a dedicated, expert sales force proactively working with end-users to solve problems and deliver true benefits
- We supply and work with a network of national, local and international distributors who can supply Ambersil products on demand
- Ambersil utilises its global connections to rapidly develop and bring to market new, tested products

## WHY WE ARE DIFFERENT

- Ambersil is dedicated to PERFORMANCE, RELIABILITY and TRUST
- Ambersil is a recognised and respected top-tier brand, worldwide
- We offer a Complete Chemical Solution for maintenance products with 100% UK availability 24/7

**“AMBERSIL IS YOUR STRATEGIC MAINTENANCE CHEMICAL PARTNER.”**

# DATA SHEETS



## REMOVING THE HEADACHE FROM SDS SHEET UPDATING

A service offered to Ambersil end-users and distributors as a means to automate the task of updating Safety Data Sheets (SDS) and Technical Data Sheets (TDS), reducing the burden on staff having to remember, schedule, and undertake this important requirement.

A unique service making compliance easy!

- 24/7 availability on-line
- Eliminates the potential to 'forget' to check for updates
- Saves time & easy to use
- Legislation changes frequently; do you always know when it has?
- Receive updates automatically
- All information held securely
- Register up to five email addresses – keeps all key personnel informed

## My Ambersil A Step By Step Guide

1 Navigate to [www.ambersil.com](http://www.ambersil.com)

2 Click on the My Ambersil logo

3 Select the link "New user: register"

4 Fill in company details and up to 5 email addresses

5 The unique log-in ID and password will be emailed to you

6 Enter the log-in ID and password on the My Ambersil homepage

7 Once logged in, select the country from the drop-down list at the top of the page (e.g United Kingdom)

8 No products will be displayed yet as My Ambersil defaults to your selected products. To add products, simply untick the 'My Selection' box

9 The complete list of Ambersil products will now be displayed - using the selection boxes on the right, both SDS and TDS updates can be selected

10 Select the Ambersil products of interest, by navigating through each page. My Ambersil remembers your selection as you move between pages, but it needs to be 'saved' by clicking 'update' before closing the website

If product selection needs to be modified, simply log-in to My Ambersil and change the update options (click on the My Ambersil logo to update email preferences)

# QUALITY & ENVIRONMENTAL



## ACCREDITED ISO 9001

We understand your reliance on quality and conformance, and value your trust in us to deliver. All Ambersil products undergo stringent quality control tests at every stage of product production.

Checks routinely performed during manufacture include:

### 1. Raw material testing

To confirm that all product ingredients are as specified

### 2. Bulk blend testing

All product batches are tested for conformance to predefined specifications before being filled into aerosol packs.

### 3. Filled aerosol testing

All filled packs are subjected to many performance and safety checks including:

- Crimp checks
- Labeling checks
- Weight checks
- Pressure checks

### 4. Water bath testing

Every single aerosol we produce passes through a hot-water bath to assess pack integrity at elevated temperatures.

### 5. Storage trials

Prior to production, Ambersil products are tested for long-term storage and reliability trials - that's why most Ambersil products have a shelf life of 6-years!

### 6. Product specific tests

Different product applications will require specific test criteria, such as accelerated corrosion testing, evaluation of release properties and material compatibility testing.

## ACCREDITED ISO 14001

At Ambersil we recognise the need to minimise our impact on the environment so that future generations can benefit from our natural heritage.

Aerosols are recognised as one of the safest methods of storing and using maintenance chemicals due to the fact that they are hermetically sealed, eliminating spill risks and reducing environmental contamination potential.

All Ambersil aerosols have been CFC free since 1989 and we are continually innovating new procedures to minimise secondary impacts on the environment from office processes and other 'behind the scenes' activities.

All Ambersil aerosols are manufactured with end-of-life disposal in mind.

- All Ambersil steel tinplate cans can be recycled
- All Ambersil boxes used for packaging and shipping are made from 100% recycled cardboard
- All aluminium aerosols can be recycled
- Plastic components may be separated & recycled

Ambersil is committed to managing its environmental performance, preventing pollution, ensuring compliance with all applicable environmental legislation. We strive to deliver continual improvement through the development, implementation and maintenance of an Environmental Management System that has been awarded the latest ISO 14001 certification.

All Ambersil products (including packaging) comply with directive 2002/95/EC on the Restriction of Hazardous Substances in electrical and electronic equipment (RoHS).



# F-GAS REGULATIONS: GUIDE FOR THE MRO MARKET

## WHAT IS AN F-GAS?

Fluorinated gases (F-gases) are a family of man-made gases used in a wide range of industrial applications, including technical aerosol products. The F-gases in use within Europe are HFC's (Hydrofluorocarbons). One of these frequently used HFC's is 134a, a refrigerant commonly used for air-conditioning, cooling systems and also as a propellant for non-flammable "Technical Aerosols". Such as Air Dusters, Freezer Sprays and other high performance aerosol products.

## UNDERSTANDING GLOBAL WARMING POTENTIAL (GWP)

The GWP of a product allows comparison between the global warming impacts of these gases, compared to the benchmark set by the theoretical warming generated by Carbon Dioxide (CO<sub>2</sub>) - (CO<sub>2</sub> GWP = 1).

F-gasses are powerful greenhouse gasses, which trap or absorb infrared heat, with a warming effect many times greater than an equivalent volume of CO<sub>2</sub>. For example, HFC-134a has a GWP of 1430 which means the emission of just 1Kg of HFC-134a has a warming impact equivalent to 1.43 tonnes of CO<sub>2</sub>.

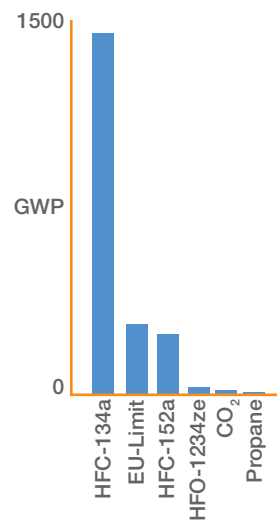

## PROTECTING THE ENVIRONMENT

The F-Gas Regulation EU 517/2014 prohibits the marketing of products with a global warming potential of more than 150 times greater than that of carbon dioxide (CO<sub>2</sub>). Effective 1<sup>st</sup> January 2018, the European aerosol industry in its entirety can neither manufacture, nor place on the European market any technical aerosol product containing F-gases with a GWP that exceeds 150. HFC-134a, with a GWP value of 1,430 is the primary constituent of most non-flammable dusters and freezers.

## IMPACT ON SUPPLIER, DISTRIBUTOR AND END USER

The scope of the legislation prohibits manufactures and marketers placing product on to the European market after 31<sup>st</sup> December 2017. Products already on the market (within the distribution channel) or in the hands of End-Users can continue to be sold or used without any deadline or limitation. As a global MRO aerosol specialist and manufacturer, Ambersil has successfully identified replacement propellants (HFO, CO<sub>2</sub> and Propane) and these are already available in our range, ensuring continuity of supply.

## PRODUCT CHOICE:

Existing users: new product cross-reference:

Discontinued	Replacement / NEW
Air Duster	Air Duster /2
Air Duster FG	
Duster LO-GWP	
Invertible Air Duster	Invertible Air Duster /2
	Duster One
Dust Remover - No Change	
Freezer	Freezer /2

See pages 21 and 25 for product specific information.

Based on existing application requirements:

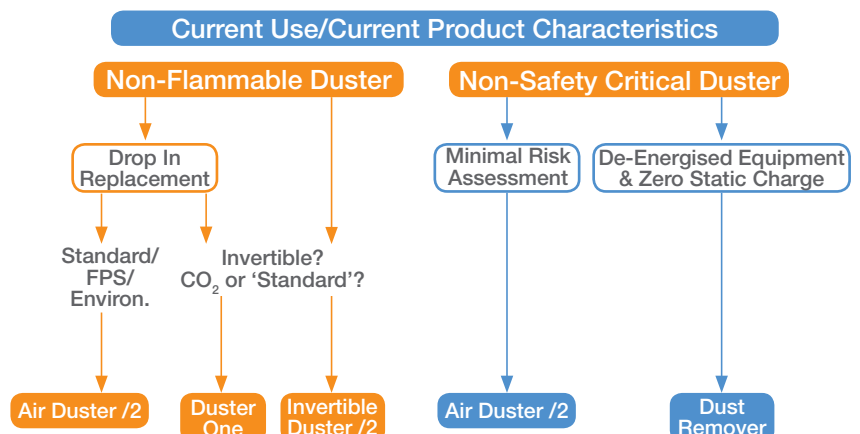

# GEOGRAPHICAL COVERAGE

## SCOTLAND & N. IRELAND

E: [sales.uk@ambersil.com](mailto:sales.uk@ambersil.com)

T: 07901 852425

POSTCODES: AB BT DD DG EH FK  
G HS IV KA KW KY ML PA PH TD  
ZE

## NORTH EAST

E: [sales.uk@ambersil.com](mailto:sales.uk@ambersil.com)

T: 07712 676695

POSTCODES: BD DH DL DN HD HG  
HU HX LN LS NE S SR TS WF YO

## MIDLANDS

E: [sales.uk@ambersil.com](mailto:sales.uk@ambersil.com)

T: 07775 740295

POSTCODES: CV DE LE MK NG  
NN OX PE

## EAST

E: [sales.uk@ambersil.com](mailto:sales.uk@ambersil.com)

T: 07901 852426

POSTCODES: AL CB CM CO E EC  
EN HA HP IG IP LU N NR NW RM  
SG SS UB W WC WD

## NORTH WEST

E: [sales.uk@ambersil.com](mailto:sales.uk@ambersil.com)

T: 07515 996564

POSTCODES: BB BL CA CH CW FY  
IM L LA LL M OL PR SK WA WN

## WALES & WEST MIDLANDS

E: [sales.uk@ambersil.com](mailto:sales.uk@ambersil.com)

T: 07901 852432

POSTCODES: B CF DY HR LD NP  
SA ST SY TF WR WS WV

## SOUTH WEST

E: [sales.uk@ambersil.com](mailto:sales.uk@ambersil.com)

T: 07901 852433

POSTCODES: BA BH BS DT EX GL  
PL PO RG SN SO SP TA TQ TR

## SOUTH EAST

E: [sales.uk@ambersil.com](mailto:sales.uk@ambersil.com)

T: 07901 852427

POSTCODES: BN BR CR CT DA GU  
KT ME RH SE SL SM SW TN TW



# ADDING VALUE TO MAINTENANCE CHEMICALS



## CHEMICAL AUDIT & CONSOLIDATION

Simplify chemical storage, ordering, and use by reducing the number of brands to the one that offers “Your Complete Chemical Solution™”.



## 24/7 GLOBAL PRODUCT AVAILABILITY THROUGH STRATEGIC SUPPLY PARTNERS

MRO chemicals available to order when you want them, worldwide, via global distribution agreements.



## ON-DEMAND DATA SHEETS (32 LANGUAGES)

The Ambersil.com website has 24/7 datasheet availability with no log in required. Every product has at least 32 language combinations for the SDS (Safety Data Sheet) ensuring safety around the world.



## REGIONALLY BASED REPRESENTATIVES

The 10 full time, fully employed, factory trained Territory Sales Managers are the first line of support for product information in the United Kingdom. International customers have dedicated brand specialists and account managers for full-services support.



## MAINTENANCE CHEMICAL PROBLEM SOLVING

In-house laboratory and development chemists are able to assist with any product and application enquiries from the simple through to chemically complex.



## INNOVATIVE SOLUTIONS FOR AUDIT COMPLIANCE

Specialist markets often require specialist solutions to compliment the product offering – in-house marketing and research teams seek to develop new, true ‘added-value’ services that benefit users and contribute to audit compliance.



## R&D INNOVATION

Dedicated in-house laboratory facilities with decades of experience in product development – part of the global CRC development network that shares ideas and research for rapid product solutions.



## MULTI-LANGUAGE CANS

Product information is displayed on all products in 6 languages. Selected products feature our “peel and read” label that has 25 languages, allowing pan-European and trans-global distribution and use.



## GHS/CLP LABELLING COMPLIANT

Regulatory compliance and forward planning ensure product availability and product safety in-line with prevailing EU Directives. Ambersil has been recognised as ISO 9001 and ISO 14001 compliant for over a decade.



## FREE PRODUCT SAMPLES

Ambersil is known for quality, reliability and trust; so why not give our products a trial with no obligation other than honest feedback? Don't just rely on our expert product recommendations, try them out for yourself.

**YOUR COMPLETE CHEMICAL SOLUTION™**

# PRODUCT DESIGN



## Multi-language cans:

- Depending on the market version, aerosol products display either 25-languages or 6-languages as standard: English, Spanish, Czech, Polish, Hungarian, Portuguese
- Ambersil products can be exported globally for international branches and end-users
- Ensures non-English-speaking employees can use products (and understand safety phrases)
- Improves user safety
- All SDS are available in up to 31 languages from [www.ambersil.com](http://www.ambersil.com)

### PRODUCT NAME

The product name is in large, clear type ensuring it stands out from the rest of the can text – essential when selecting which product to use

### RANGE ICON

The Ambersil icon, clearly presented on the front of the product indicates which product range type it belongs to, assisting in easy product identification

### PRODUCT DESCRIPTION

The product description is always located directly below the range icon in bold text so that users can clearly see what the product function is.

### KEY FEATURES

Product features are prominently displayed assisting in correct product selection.

### SAFETY COMPLIANCE

Conforms to ADD for proven product safety

### HAZARD SYMBOLS

Clearly displayed on every product (if required), the internationally recognised CLP symbols communicate relevant hazards and precautions

### PRODUCT INFORMATION

The reverse of every can (and most other pack types) clearly indicates the product description and full safety texts in multiple languages

### OUR CONTACT DETAILS

We love to hear from customers and users so every product has our details on; ask us questions or request more information

### MULTI-LANGUAGE

With a growing need to offer more language sets, we now have 40 products with our Peel and Read label, offering 25 languages.



# PRODUCT MODULE:

## RELEVANT INFORMATION FOR PRODUCT SELECTION

The product modules have been designed specifically to assist in the research, comparison and selection of the products. With easy to understand information such as the innovative use of 'attribute graphs' that offer a simplified representation of the product; and a QR code that instantly links to the website product page for Safety Data Sheet (SDS) & Technical Data Sheet (TDS) download.

### PRODUCT IMAGE

Clearly shows what the actual product looks like, for easier recognition

### APPLICATION TEXT

Example(s) of how and where the product can be used. The bullet points emphasise a selection of the key features (more are available via the QR code)

### APPROVAL ICONS

Many products carry industrial, military, aviation, or other approvals. These icons identify approvals associated with the product

### PRODUCT NAME

Product name, as displayed on the front of the product

### MULTI-LANGUAGE CANS

Products variations with either 6 or 25 languages on the can. Not all products have both options



## AMBERCLENS

### ANTI-STATIC FOAMING CLEANER

Use to remove general grime and soiling on all surfaces. Particularly effective as a post-maintenance cleaner for removing finger marks and oil residues. Anti-Static formulation inhibits dust attraction.

- Removes light oils, finger marks, and general grime.
- Safe for use on plastics, metals, painted and glazed surfaces
- Multiple industrial approvals: Rail, NATO, Ford, British Coal, Rolls Royce Aerospace
- Available as a non-flammable propellant version "Amberclens NB"

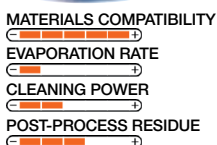
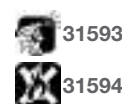
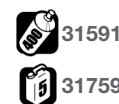

### ATTRIBUTE GRAPHS

The attribute graphs have been developed to be used as a simplified guide for comparing the key attributes of products, aiding product selection

### PRODUCT CODES/PACK SIZE

Products are often available in multiple fill sizes, from aerosols to larger bulk packs. These product fill icons indicate the fill size and container type along with the relevant product code for each variant

### QR CODE

Scan with a smart phone or digital device with internet access to view datasheets, compliance letters, and product videos

# CLEANERS

Remove dirt, grease & grime with the most comprehensive range of industrial maintenance cleaners and degreasers

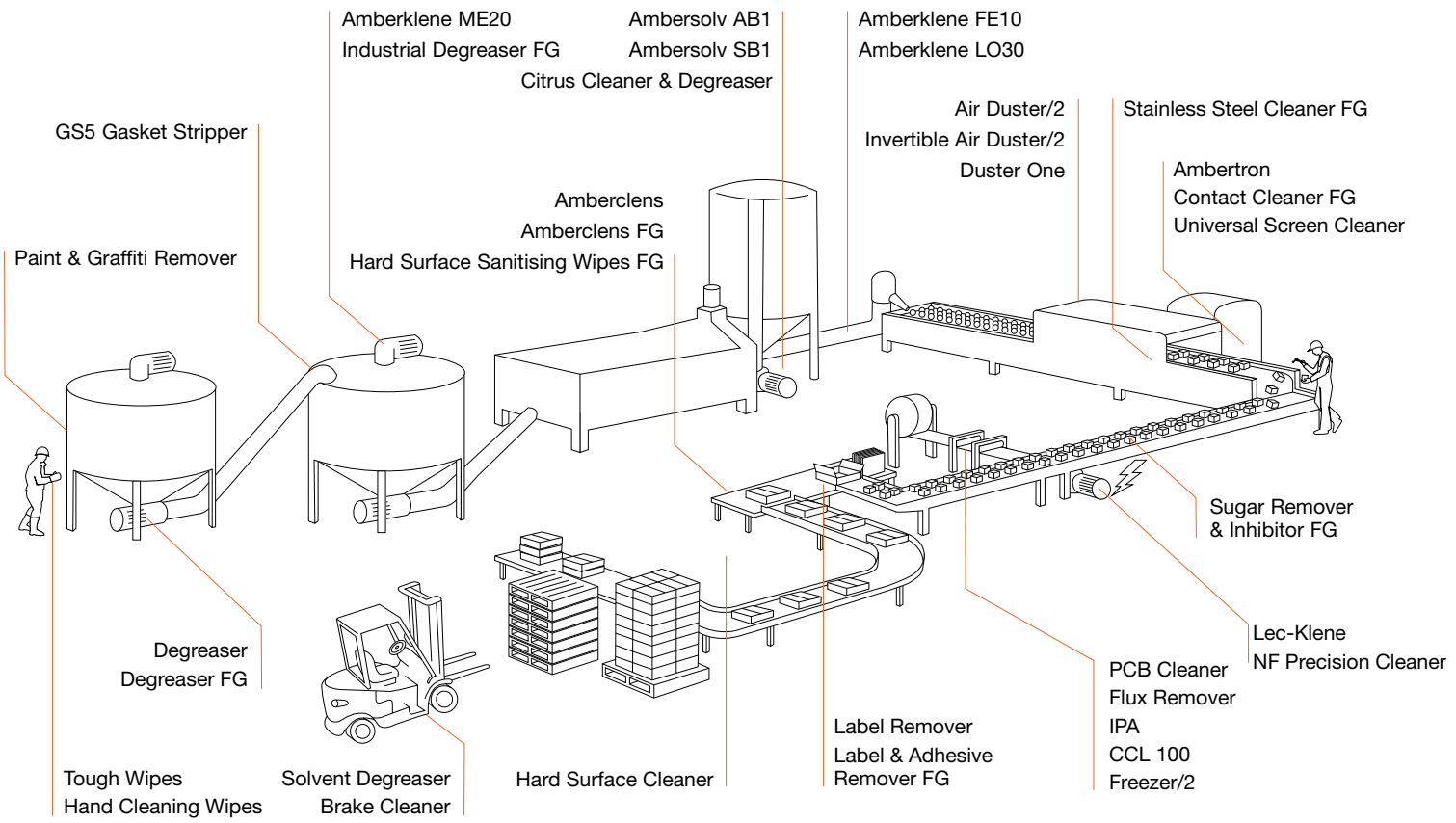

Misrepresentation Act 1967, Trade Descriptions Act 1968

The information given in this publication is based on our experience and reports from customers. There are many factors outside our control and knowledge which affect the use and performance of our products and for which reason no warranty is given, express or implied. Users should make their own tests to determine the applicability of such information or the suitability of any products for their own particular purposes. Statements concerning the use of the products described herein are not to be construed as recommending the infringement of any patent and no liability for infringement arising out of any such use is to be assumed.

# Cleaners Selection Chart

## GENERAL CLEANING

CLEANING POWER			
⊕		DEGREASER RTU	14
		DEGREASER FG	15
		AMBERSOLV / AB1	14
		HARD SURFACE CLEANER	16
		AMBERCLENS	14
		AMBERCLENS FG	14
		UNIVERSAL SCREEN CLEANER	24
		STAINLESS STEEL CLEANER FG	15
		SUGAR REMOVER & INHIBITOR FG	15
⊖			

## SOLVENT DEGREASING

CLEANING POWER			
⊕		BA40 SOLVENT	21
		FAST CLEAN 200	21
		AMBERSOLV SB1	21
		INDUSTRIAL DEGREASER FG	20
		AMBERKLENE ME20	19
		AMBERKLENE FE10	19
		BRAKE CLEANER	19
		AMBERKLENE FG	19
		AMBERKLENE LO30	17
		WHITE SPIRIT	20
		SOLVENT DEGREASER	24
		LABEL REMOVER	24
⊖		LABEL & ADHESIVE REMOVER FG	20

## ELECTRONICS CLEANING

CLEANING POWER			
⊕		FLUX REMOVER	26
		LEC-KLENE	21
		AMBERKLENE LO30	19
		NF PRECISION CLEANER	25
		PCB CLEANER	26
		AMBERTRON	25
		CONTACT CLEANER FG	25
		CCL 100	26
		IPA SOLVENT	26
		ULTRASONIC CLEANING FLUID	27
		UNIVERSAL SCREEN CLEANER	24
⊖		AIR DUSTERS	23

## SPECIALIST CLEANING

CLEANING POWER			
⊕		GASKET STRIPPER GS5	22
		PAINT & GRAFFITI REMOVER	22
		TERRAZZO CLEANER	16
		TRAFFIC FILM REMOVER	16
		SBP11	17
		DP17	16
		HARD SURFACE CLEANER	16
		CITRUS CLEANER	15
		GLASS CLEANER	22
⊖		MULTI-SURFACE POLISH	22



## AMBERCLENS

### ANTI-STATIC FOAMING CLEANER

Use to remove general grime and soiling on all surfaces. Particularly effective as a post-maintenance cleaner for removing finger marks and oil residues. Anti-Static formulation inhibits dust attraction.

- Removes light oils, finger marks, and general grime.
- Safe for use on plastics, metals, painted and glazed surfaces
- Multiple approvals: Rail, NATO, Ford, British Coal, Rolls Royce Aerospace
- Available as a non-flammable propellant version "Amberclens NB"

MATERIALS COMPATIBILITY  
EVAPORATION RATE  
CLEANING POWER  
POST-PROCESS RESIDUE

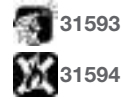
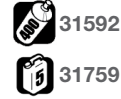

## AMBERCLENS FG

### FOOD GRADE FOAM CLEANER

Developed for general cleaning in the food industry. Use to remove general grime and soiling from machinery.

- NSF A1 registered (No.137995)
- Stable, non-dripping foam helps break down soiling for effective cleaning
- Cleans equipment, metal parts, and machinery
- Biodegradable

MATERIALS COMPATIBILITY  
EVAPORATION RATE  
CLEANING POWER  
POST-PROCESS RESIDUE



## AMBERSOLV AB1/FOAMING CLEANER

### WATER-BASED CITRUS CLEANER

Water-based cleaner with added citrus power. Use to clean around gearboxes, pumps and for removing hydraulic oil leak residue.

- Removes difficult soiling such as: oil, grease residue, grime, silicone, water-based paints and inks/dyes
- Ideal as a post-maintenance cleaner or as a general cleaner for removing more stubborn soiling
- Biodegradable
- Removes bitumen residue & softens resins and some adhesives
- Approved for cleaning aircraft exterior surfaces

MATERIALS COMPATIBILITY  
EVAPORATION RATE  
CLEANING POWER  
POST-PROCESS RESIDUE

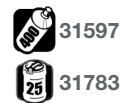

## DEGREASER RTU & DEGREASER LOW FOAM

### TOUGH WATER-BASED DEGREASER

Use to degrease components when a regular solvent cleaner cannot be used. Ideal for gearboxes, hydraulic systems, open gears, chains and pumps to remove a variety of soiling types.

- Removes tough, stubborn soiling such as heavy oil, grease, grime, silicones, wax and old lubricants
- Safe for use on most plastics, rubber and painted surfaces
- Available as Low Foam (LF) for automated applications
- Contains a highly effective corrosion inhibitor to help prevent flash rusting

MATERIALS COMPATIBILITY  
EVAPORATION RATE  
CLEANING POWER  
POST-PROCESS RESIDUE

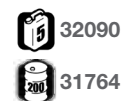
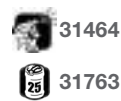



MATERIALS COMPATIBILITY  
 EVAPORATION RATE  
 CLEANING POWER  
 POST-PROCESS RESIDUE

## DEGREASER FG

### NSF A1 WATER BASED DEGREASER

Use to degrease components when a regular solvent degreaser cannot be used. Formulated specifically for use in the food/beverage industry for risk reduction.

- NSF A1 registered (No.137997)
- Readily biodegradable
- Effective in both hot and cold water
- Use on gearbox housing, hydraulic systems, large panels, and even walls and floors.
- Concentrated for convenience and economy
- Non-flammable



30243



MATERIALS COMPATIBILITY  
 EVAPORATION RATE  
 CLEANING POWER  
 POST-PROCESS RESIDUE

## STAINLESS STEEL CLEANER FG

### DUAL ACTION CLEANER AND POLISH

For use on all types of stainless steel and other 'shiny' metals to remove light oils, fingerprints, and water marks.

- NSF A7 and C1 registered (No.138212)
- Dual action: cleans and polishes in one application
- Dense foam allows use on vertical surfaces without dripping
- Leaves an invisible, non-greasy film for lasting shine
- Ideal post-maintenance cleaner



30249



MATERIALS COMPATIBILITY  
 EVAPORATION RATE  
 CLEANING POWER  
 POST-PROCESS RESIDUE

## SUGAR REMOVER & INHIBITOR FG

### CLEANER FOR SUGAR DEPOSIT REMOVAL

Highly effective thin cleaning fluid that penetrates and lifts sugar, fondant, plant sugar extracts, and sugar derivatives from equipment surfaces.

- NSF H1 registered (No.144180)
- Formulated using only food grade acceptable components
- Leaves a light lubricating film that inhibits re-adhesion for easier clean-down
- Helps reduce scraping and improves equipment performance



32082

31590



MATERIALS COMPATIBILITY  
 EVAPORATION RATE  
 CLEANING POWER  
 POST-PROCESS RESIDUE

## CITRUS CLEANER & DEGREASER

### WATER-BASED CITRUS CLEANER

A powerful yet versatile cleaner and degreaser. Formulated as a complex micro emulsion of citrus oils and surfactants.

- An alternative to traditional solvents and highly alkaline cleaning agents
- Particularly effective on hard surfaces such as large pump housings, gearboxes and pipework
- Safe on most rubbers, plastics and coatings
- Suitable for use in ultra-sonic cleaners



32089





## HARD SURFACE CLEANER



### WATER-BASED MULTI-SURFACE CLEANER

An environmentally preferred non-flammable product that can be used on all floors as a cleaner to remove oil, grime and common soiling types.

- Can be used on almost any hard surface: concrete floors, walls, doors, marble, duct-work, signs, terrazzo, and more
- Particularly effective on sealed warehouse flooring, vinyl corridor tiles, and canteen floors
- Can be used with hot or cold water
- Very economical in use



MATERIALS COMPATIBILITY  
 EVAPORATION RATE  
 CLEANING POWER  
 POST-PROCESS RESIDUE



31761 31768



## TRAFFIC FILM REMOVER



### VEHICLE AND PLANT CLEANER

Use in automated vehicle exterior cleaning systems for HGV, mass transit and fleet cleaning.

- Easily and quickly removes oily soiling and road grime from vehicle bodies, chassis and side curtains
- Water soluble and can be diluted
- Safe for use on paint, bodywork, plastics and rubber
- Suitable for use with hot and cold water



MATERIALS COMPATIBILITY  
 EVAPORATION RATE  
 CLEANING POWER  
 POST-PROCESS RESIDUE



31760 31779



## DP17



### EXTERIOR CLEANER FOR TRAINS

A mildly alkaline concentrated cleaner for the exterior of trains and other rolling stock.

- Non-corrosive to all commonly used metals, rubbers and elastomers
- Fully biodegradable surfactants
- Formulated to be used in automated train cleaning equipment
- Suitable for manual cleaning operations
- Rail approved (007/021836)



MATERIALS COMPATIBILITY  
 EVAPORATION RATE  
 CLEANING POWER  
 POST-PROCESS RESIDUE

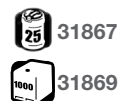

31867 31868



## TERRAZZO CLEANER



### ANTI-SLIP FLOOR CLEANER

Cleaner for anti-slip flooring that rapidly and effectively removes dirt and grime.

- Microscopically roughens terrazzo surface to provide grip when the floor is wet
- Economical in use
- Rail approved (007/025012)



MATERIALS COMPATIBILITY  
 EVAPORATION RATE  
 CLEANING POWER  
 POST-PROCESS RESIDUE



31872





## WHITE SPIRIT



### PETROLEUM DISTILLATE SOLVENT

Ideal for general, low intensity degreasing of parts and components.

- Highly refined to give consistent results
- Superior wetting out properties ensures effective contamination contact and performance
- Can be used as a general purpose thinner
- Conforms to BS 245
- Rail approved (007/029302)

#### MATERIALS COMPATIBILITY

EVAPORATION RATE

CLEANING POWER

POST-PROCESS RESIDUE



32642



32643



## SBP 11



### VERSATILE CLEANING SOLVENT

A complex mix of hydrocarbons that rapidly breaks down grime for effective train and rolling stock cleaning.

- Formulated with a slower evaporation rate for longer contact time on heavy and old grease and lubricant deposits.
- The powerful solvent blend enables this degreaser to penetrate tough, oily, and viscous contamination easily.
- Rail approved (007/068267)

#### MATERIALS COMPATIBILITY

EVAPORATION RATE

CLEANING POWER

POST-PROCESS RESIDUE



32645



## HAND CLEANER PLUS



### PROFESSIONAL GRADE WORKSHOP HAND CLEANER

Solvent-free hand cleaner with Aloe Vera, jojoba and environmentally-friendly abrasives. Formulated for engineering workshops and professional users. Rapidly removes: lubricants, grease, tar, bitumen, most paints, grime and general soiling.

- Powerful performance yet mild on skin
- Easily removed with fresh water
- Does not contain alcohol or solvent
- Contains moisturising agents and biodegradable abrasives
- Exceptionally economical in use

CLEANING POWER

ANTI-PATHOGEN

SKIN KIND

DRYING TIME



33174



## TOUGH WIPES



**HIGH ABSORBENCY HAND CLEANING WIPE**  
 High absorbency hand wipes over-layered with a polymer web for all the deep cleaning power of pumice in a handy wipe.

- Highly effective on a range of soiling types: adhesives, grease, oil, tar, silicone, resins, paints, and more
- Contains anti-pathogen agents highly effective against common bacteria and viruses such as Weils Disease, MRSA, Salmonella, Listeria, and E.Coli. Passes BS 12054 (hand sanitising) and BS 1276 (surface sanitising)
- No contamination or lasting fragrance from heavy perfumes



30 30766

100 30767



- CLEANING POWER
- ANTI-PATHOGEN
- SKIN KIND
- DRYING TIME

## HAND CLEANING WIPES



**READY TO USE HAND & TOOL WIPES**

Use for cleaning light to moderate grime and oil from tools, hands, and equipment.

- Economical hand cleaning - 150 wipes per tub
- Keeps expensive hand tools clean
- Multi-purpose disposable wipes
- Combats common germs
- Excellent materials compatibility



150 31798



- CLEANING POWER
- ANTI-PATHOGEN
- SKIN KIND
- DRYING TIME

## HARD SURFACE SANITISING WIPES FG



**“NO RINSE REQUIRED” SANITISING WIPES**

Hard surface sanitising wipes developed for the food and beverage industry. Suitable for use on production lines and in processing areas.

- Kills common pathogens such as: Staphylococcus aureus, E.Coli, Pseudomonas aeruginosa, and Enterococcus hirae
- Sanitised surfaces do NOT require a rinse after product use, ensuring production efficiency and speed is maintained
- Highly visible blue wipes for contamination risk reduction
- NSF D2 registered (No.147561)



1000 32325



- CLEANING POWER
- ANTI-PATHOGEN
- FOOD SAFE
- DRYING TIME

## ENGINEERS WIPES



**LOW/ZERO LINT CLEANING WIPES**

High quality, extremely low lint dry wipes for use with all Ambersil solvents, cleaners, lubricants.

- Tear resistant and “non-linting”
- Suitable for use with all Ambersil chemicals
- Excellent wet strength - resists tearing and can be reused
- Ideal for use on delicate surfaces: computer monitors, touch screens, LCD/plasma screens, and more
- Highly absorbent



50 31797



- MATERIALS COMPATIBILITY
- EVAPORATION RATE
- CLEANING POWER
- POST-PROCESS RESIDUE



## AMBERKLENE FE10

### FAST DRYING SOLVENT DEGREASER

Use for the general degreasing of machinery including chains, gears, bearings, drives, motors, and more.

- Powerful flushing action rapidly dissolves and removes contaminants
- Safe for use on all metals and most plastics
- Zero residue - perfect for surface preparation prior to bonding, painting, coating, or relubrication
- Fitted with the Ambersil 360 degree spray system for all angle use

MATERIALS COMPATIBILITY  
 EVAPORATION RATE  
 CLEANING POWER  
 POST-PROCESS RESIDUE

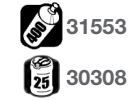

## AMBERKLENE ME20

### HEAVY DUTY SOLVENT

Formulated with a slower evaporation rate for longer contact time on heavy grease and old lubricant deposits.

- Removes heavy, old, and significant deposits of oil, grease, waxes and silicone
- Superior wetting properties ensures extended contact time and solvency performance
- Higher flash point of 41°C for application safety
- Leaves a clean, dry, residue free surface

MATERIALS COMPATIBILITY  
 EVAPORATION RATE  
 CLEANING POWER  
 POST-PROCESS RESIDUE



## AMBERKLENE LO30

### LOWER ODOUR SOLVENT DEGREASER

Use for general light degreasing on bearings, motors, gears and chains without the traditional odour associated with solvent degreasers.

- Safe for use on ferrous and non-ferrous metals, most painted surfaces, and most plastics
- Will not stress-crack acrylic
- Listed in British Airways 'Standard Practice' manual. Meets US Federal Spec. TT-N-95Bv Type 2; and is approved by Ford Motor Company (Tox: 166741)

MATERIALS COMPATIBILITY  
 EVAPORATION RATE  
 CLEANING POWER  
 POST-PROCESS RESIDUE

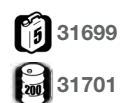
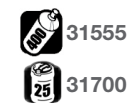

## BRAKE CLEANER

### AUTOMOTIVE SOLVENT CLEANER

Use on all brakes and clutches to remove dust deposits, oil, grease, and other contaminants. Also removes anti-corrosion coatings on new brake discs prior to fitting.

- Reduces disc brake squeal and clutch chatter
- Can be used as a general purpose degreaser

MATERIALS COMPATIBILITY  
 EVAPORATION RATE  
 CLEANING POWER  
 POST-PROCESS RESIDUE





## INDUSTRIAL DEGREASER FG

### HEAVY DUTY, FAST EVAPORATING SOLVENT

Formulated for use in the food/beverage industry to tackle 'difficult' degreasing applications. Excellent general purpose solvent degreaser.

- NSF A8 and K1 registered (No.140255 and 140250)
- Powerful flushing action with superior wetting properties ensures excellent results
- Zero residue

FOOD PROCESSING SAFE

NSF A8 NSF K1

30251 30252

MATERIALS COMPATIBILITY

EVAPORATION RATE

CLEANING POWER

POST-PROCESS RESIDUE



## SOLVENT CLEANER FG

### LOW ODOUR SOLVENT DEGREASER

Use for the general degreasing of mould tools, bearings, and equipment in the food and beverage sector.

- NSF K1 registered (No.149687)
- Minimal odour
- Cuts through oils, grease residues, mould release agents, polymer residues, and anti-corrosion coatings
- Zero residue
- Good materials compatibility

FOOD PROCESSING SAFE

NSF K1

32448

MATERIALS COMPATIBILITY

EVAPORATION RATE

CLEANING POWER

POST-PROCESS RESIDUE



## SOLVENT DEGREASER

### WATER RINSABLE DEGREASER

Use for engine and equipment degreasing which can be washed down, or for use in enclosed environments where vapours need to be minimised.

- Contains a highly effective emulsifier that enables dissolved oil/grease residues to mix with water for easy wash-off
- Higher flash point of 39°C for application safety
- Contains rust inhibitor to prevent flash rusting

NSF A8

31558 31770 31771 30318

MATERIALS COMPATIBILITY

EVAPORATION RATE

CLEANING POWER

POST-PROCESS RESIDUE



## AMBERKLENE FG

### BIODEGRADABLE SOLVENT DEGREASER

A medium/slower evaporation solvent degreaser for use in the food/beverage sector. Use to remove grease and oils from bearings, housings, conveyor drives, chains and even wax-based anti-corrosion coatings.

- NSF A8 and C1 registered (No.137996 and 140261)
- Higher flash point of 40°C for application safety

FOOD PROCESSING SAFE

NSF A8 NSF C1

30242 30250

MATERIALS COMPATIBILITY

EVAPORATION RATE

CLEANING POWER

POST-PROCESS RESIDUE



## LEC-KLENE

### HIGH FLASH POINT SOLVENT DEGREASER

An advanced high flash point solvent degreaser for electronic and aviation components. The ultra-pure formulation delivers a good level of solvency power with excellent materials compatibility.

- A fast and effective general purpose degreaser
- Higher flash point (>62°C) for application safety
- Use where DEF STAN 68-148 is specified
- No detrimental effect on painted surfaces, ferrous or non-ferrous metals, epoxy based composites, acrylic sheet, plastics, and rubber

MATERIALS COMPATIBILITY  
EVAPORATION RATE  
CLEANING POWER  
POST-PROCESS RESIDUE



- 31557
- 31702
- 31704

- 31969
- 31703



## AMBERSOLV SB1

### CITRUS BASED SOLVENT DEGREASER

A solvent degreaser with added citrus power for use on grease and grime that may contain multiple contamination types.

- Effective on a wide range of soiling such as: oil, grease, tar, bitumen, silicones, rubber-based adhesives, oil-based paints, inks and dyes
- Safe for use on most plastics and all metals & cable insulation
- Military & Aviation approved
- Low toxicity, inherently biodegradable

MATERIALS COMPATIBILITY  
EVAPORATION RATE  
CLEANING POWER  
POST-PROCESS RESIDUE

- 31598
- 31786

- 31785



## FAST CLEAN 200/201

### EXTRA FAST & POWERFUL SOLVENT

An advanced degreasing solvent that has both exceptionally fast drying speed and very high solvency power.

- Removes heavy, old, and dried-on deposits of oil, grease, waxes and silicone
- Powerful flushing action rapidly dissolves and removes contaminants
- Non-chlorinated
- Zero residue

MATERIALS COMPATIBILITY  
EVAPORATION RATE  
CLEANING POWER  
POST-PROCESS RESIDUE

- 31890
- 32115

- 32114



## BA40 SOLVENT

### AVIATION SPECIFIED SOLVENT CLEANER

Developed specifically for the demands of the aviation industry for a cleaner to remove uncured polysulphide sealant.

- Also removes other stubborn residues such as: adhesives, inks, resins, varnishes and lacquers
- Powerful solvent for excellent penetration but with rapid evaporation for maximum efficiency
- Low pressure spray provides an even coverage and prevents splash back in use
- Zero residue

MATERIALS COMPATIBILITY  
EVAPORATION RATE  
CLEANING POWER  
POST-PROCESS RESIDUE

- 31556





## PAINT & GRAFFITI REMOVER

### POWERFUL PAINT REMOVER

A highly effective solution to the difficult problem of removing graffiti and old paint.

- Rapidly softens existing paint for easier removal prior to repainting with Ambersil Acrylic Paint or Galva Colour
- For use on hard, non-porous surfaces. Test substrate compatibility prior to use
- Softens acrylic paint in 3 minutes, and softens tough paints in 10 minutes



31630



- MATERIALS COMPATIBILITY  
 EVAPORATION RATE  
 CLEANING POWER  
 POST-PROCESS RESIDUE



## GASKET STRIPPER GS5

### UNIVERSAL GASKET STRIPPER

Removes in-place gaskets from gearboxes, drives, chain enclosures, and engines.

- Use to remove thread locking compounds, silicone sealant, and mastics
- Foaming formulation extends contact time and assists in gasket softening
- Fast acting: works in less than 20 minutes
- Reduces scraping and potential damage to surfaces



31891



- MATERIALS COMPATIBILITY  
 EVAPORATION RATE  
 CLEANING POWER  
 POST-PROCESS RESIDUE



## MULTI-SURFACE POLISH

### CLEANER AND POLISH FOR HARD SURFACES

Developed to cut through and remove industrial soiling which is often more tenacious than domestic dust/grime.

- Wax/silicone blend provides a durable, high gloss shine
- Pleasant fragrance leaves the area smelling fresh and clean
- Works rapidly to capture dust and grime for rapid “one-application” cleaning
- Use with Ambersil Engineers Wipes for best results



31627



- MATERIALS COMPATIBILITY  
 EVAPORATION RATE  
 CLEANING POWER  
 POST-PROCESS RESIDUE



## GLASS CLEANER

### FOR GLASS AND GLAZING

Use on all glazed and ceramic surfaces to remove light soiling and marks.

- Produces a smear-free and residue-free finish with minimal effort
- Incredible results, first time
- Automotive approval: Ford Tox No: 177057



31596



- MATERIALS COMPATIBILITY  
 EVAPORATION RATE  
 CLEANING POWER  
 POST-PROCESS RESIDUE





## AIR DUSTER /2

### NON-FLAMMABLE DUSTER FOR ELECTRONICS

A high pressure, inert, liquefied gas that safely removes dust and loose debris with a powerful 'air' jet. Helps prevent electronic component errors or downtime.

- NSF K2 Registered (No. 157081)
- Safe for use on all surfaces, electronic components, and sensors
- Does not contain CFC's, HFC's, and is non-ozone depleting
- Powerful blast easily displaces loose contamination
- Non-flammable (directive 2008/47/EC) & zero odour in use
- GWP of just 6



MATERIALS COMPATIBILITY  
EVAPORATION RATE  
CLEANING POWER  
POST-PROCESS RESIDUE



## INVERTIBLE AIR DUSTER /2

### "ALL ANGLE" DUSTER FOR ELECTRONICS

A powerful, dry 'air' blast for the removal of dry contaminants from electronics.

- Ideal for safety critical applications
- Invertible valve system virtually eliminates the potential for moisture contamination of delicate electronics
- Non-flammable (directive 2008/47/EC) & zero odour in use
- Does not contain CFC's, HFC's, and is non-ozone depleting
- 360° Spray System allows use at all angles
- GWP of just 6



MATERIALS COMPATIBILITY  
EVAPORATION RATE  
CLEANING POWER  
POST-PROCESS RESIDUE



## DUSTER ONE

### INERT, ENVIRONMENTALLY NEUTRAL DUST REMOVER

Environmentally neutral, non-flammable, and invertible 'air' duster for the rapid and effective removal of loose contamination from electronics and optics. Duster One utilises 'Active Carbon Capture Technology™' to maximise performance and efficiency.

- Duster with Active Carbon Capture Technology (ACCT)
- Invertible for use at all angles
- Global Warming Potential (GWP) of 1
- For use on electronics and optics



MATERIALS COMPATIBILITY  
EVAPORATION RATE  
CLEANING POWER  
POST-PROCESS RESIDUE



## DUST REMOVER

### NON-SAFETY CRITICAL DUSTER

An economical duster developed to meet the market demand for a non-safety-critical duster.

- Ensure all equipment is de-energised and static electricity has been eliminated prior to use
- Powerful 'air' blast rapidly removes loose contamination
- Ideal for use on delicate electronics
- Does not contain CFC's, HCFC's, and is non-ozone depleting
- GWP of 3.5
- This product is flammable



MATERIALS COMPATIBILITY  
EVAPORATION RATE  
CLEANING POWER  
POST-PROCESS RESIDUE



## ANTI-STATIC SPRAY

### DISSIPATES STATIC BUILD UP

Use on any surface prone to static charge prior to maintenance, or as part of a static control programme.

- Rapidly reduces electrostatic charges
- Quick and easy to use
- Non-toxic and biodegradable
- Particularly useful in the paper and textile industries, and anywhere prone to airborne dust

MATERIALS COMPATIBILITY  
 EVAPORATION RATE  
 CLEANING POWER  
 POST-PROCESS RESIDUE



31561



## UNIVERSAL SCREEN CLEANER

### FOAMING VDU SCREEN CLEANER

Removes finger-marks and contamination from visual display units (VDU's) such as LCD monitors and production control screens. Ideal for cleaning thermal imaging camera screens.

- Can be used on most screen types (LCD, TFT, Plasma, etc.)
- Exceptionally economical in use
- NSF P1 registered (No.147407)

MATERIALS COMPATIBILITY  
 EVAPORATION RATE  
 CLEANING POWER  
 POST-PROCESS RESIDUE



30236



## LABEL REMOVER

### SELF-ADHESIVE LABEL AND STICKER REMOVER

An optimum blend of solvent and citrus active ingredients which will penetrate paper labels rapidly to soften the adhesive.

- Reduces the need for scraping and the potential damage that may cause
- Improves packaging line efficiency by reducing jamming caused by label and adhesive build-up
- Pleasant citrus smell
- Test plastics compatibility prior to use

MATERIALS COMPATIBILITY  
 EVAPORATION RATE  
 CLEANING POWER  
 POST-PROCESS RESIDUE



31629



## LABEL & ADHESIVE REMOVER FG

### FOOD GRADE LABEL & ADHESIVE REMOVER

Use for the removal of packaging and transport labels from shipping containers, plastic boxes, and bulk storage (intermediate) drums.

- NSF K3 registered (No.140259)
- An optimum blend of solvent and citrus active ingredients penetrate paper labels rapidly
- Use on packaging lines to remove label & adhesive build up
- Minimises the requirement for scraping

MATERIALS COMPATIBILITY  
 EVAPORATION RATE  
 CLEANING POWER  
 POST-PROCESS RESIDUE



30254







## AMBERTRON

### ULTRA PURE CONTACT CLEANER

Ultra pure formulation for critical maintenance. Removes light oils and contamination safely from PCB's, relays, all electrical contacts, switches, and more.

- Excellent materials compatibility: safe for use on plastics, rubber, composites, metal and painted surfaces
- Non-conductive
- Quick and effective cleaning with zero residue
- Automotive approval: Ford Tox No: 166300 and Rail approved: 007/007224
- Will not produce frost

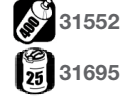

MATERIALS COMPATIBILITY  
 EVAPORATION RATE  
 CLEANING POWER  
 POST-PROCESS RESIDUE



## NF PRECISION CLEANER

### NON-FLAMMABLE CONTACT CLEANER

An advanced solvent contact cleaner that is non-flammable and ideal for servicing critical electronics that cannot be switched off or de-energised.

- Excellent materials compatibility: safe for use on plastics, rubber, composites, metal and painted surfaces
- Passes flame extension test FEA 607E and Drum test FEA 610E for genuine non-flammable performance



MATERIALS COMPATIBILITY  
 EVAPORATION RATE  
 CLEANING POWER  
 POST-PROCESS RESIDUE



## CONTACT CLEANER FG

### FOOD GRADE ELECTRICAL CONTACT CLEANER

Designed for electrical component maintenance in the food industry, particularly for on-line production electrics and similar delicate equipment.

- NSF K2 Registered (No.139627)
- Use to remove grime and contamination from PCB's and electronics
- Reduces voltage drop due to contamination
- Non-corrosive and non-conductive



MATERIALS COMPATIBILITY  
 EVAPORATION RATE  
 CLEANING POWER  
 POST-PROCESS RESIDUE





## IPA SOLVENT

### ISOPROPYL ALCOHOL CLEANING SOLVENT

A gentle yet highly effective alcohol based cleaner for use on optical devices, switches, PCB's and on general electronics.

- Excellent materials compatibility: safe for use on plastics, rubber, composites, metal and painted surfaces
- Conforms to BS 1595, ASTM D770, and DIN 53245
- Zero residue
- Removes moisture



MATERIALS COMPATIBILITY  
 EVAPORATION RATE  
 CLEANING POWER  
 POST-PROCESS RESIDUE



## PCB CLEANER

### ELECTRONICS CLEANING SOLVENT

Removes light soiling from PCB's in a wide range of electrical and electronic equipment.

- Exhibits enhanced solvency power over a standard contact cleaner for removal of light contamination accumulation from PCB boards and other electronic components.
- Excellent materials compatibility: safe for use on plastics, rubber, composites, metal and painted surfaces



MATERIALS COMPATIBILITY  
 EVAPORATION RATE  
 CLEANING POWER  
 POST-PROCESS RESIDUE



## FLUX REMOVER

### FLUX REMOVER AND DEGREASER

Removes flux residues after electronic component repair. The bespoke formulation allows the solvent blend to penetrate contamination rapidly, and leaves a residue free surface.

- Removes both organic and in-organic fluxes and residues from PCB's
- Excellent materials compatibility: safe for use on plastics, rubber, composites, metal and painted surfaces



MATERIALS COMPATIBILITY  
 EVAPORATION RATE  
 CLEANING POWER  
 POST-PROCESS RESIDUE



## CCL 100

### 3-IN-1 CONTACT CLEANER LUBRICANT

A versatile product for use on electrical switchgear and electric motor contacts. Ideal for use on radar systems where contacts may be exposed to moisture.

- Cleans, lubricates, and prevents corrosion in one application
- Removes light oils, light grease, tarnish, and oxidation
- Cuts voltage drop between contacts
- Leaves an oily conductive film for contact protection and prevents arcing



MATERIALS COMPATIBILITY  
 EVAPORATION RATE  
 CLEANING POWER  
 FILM VISCOSITY





# LUBRICANTS, GREASES & OILS

From multi-purpose lubricants through to fully synthetic gear oils, Ambersil lubricants keep the wheels of industry turning

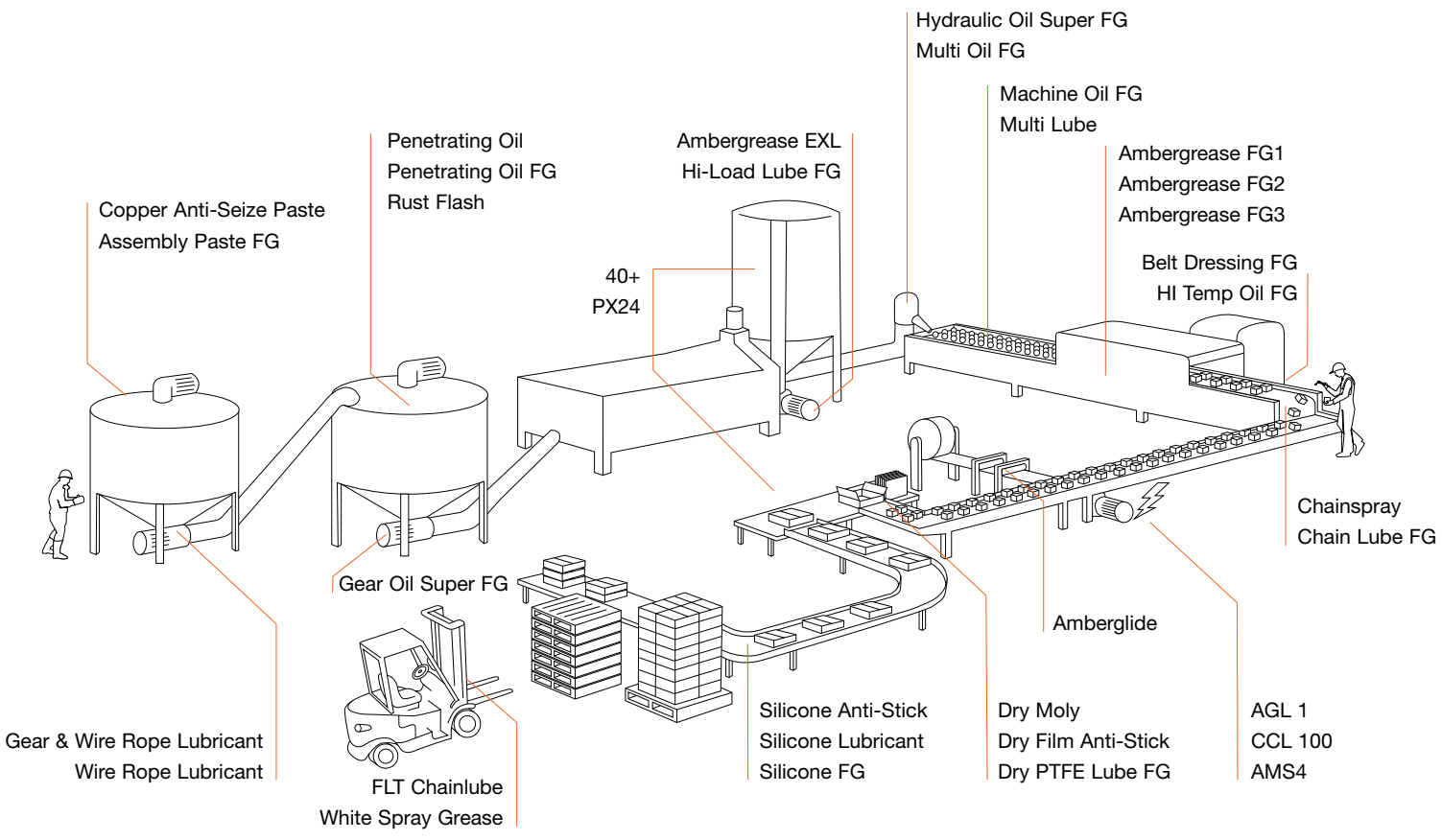

# Lubricants Selection Chart

Product Type	Application Requirement	Type of Duty	Recommended Product	Page
<b>Multi-Purpose</b>	Military Grade		➔ PX24	30
	Food Processing Safe®		➔ MACHINE OIL FG	31
	Multiple Industrial Approvals		➔ 40+	30
	General Purpose		➔ MULTI-LUBE	31
	Greaseless/Thin-Film		➔ AGL1	30
<b>PTFE Lubricants</b>	Wet-Film	Oily	➔ AMBERGLIDE	33
		Chain Lubricant	➔ CHAIN LUBE FG	35
	Dry Film		➔ DRY FILM ANTI-STICK	33
		Food Processing Safe®	➔ DRY PTFE LUBE FG	33
<b>Silicone Lubricants</b>	Grease		➔ AMS4 SILICONE GREASE	39
	High Concentration Silicone		➔ SILICONE ANTI-STICK	32
	General Purpose Silicone		➔ SILICONE LUBRICANT	32
	Food Processing Safe®		➔ SILICONE FG	32
<b>MoS<sub>2</sub> Lubricants</b>	Dry Film Lubricant		➔ DRY MOLY	33
	Wet Film		➔ CHAINSPRAY	34
<b>Graphite</b>	Lock Lubricant		➔ GRAPHITE LOCK LUBE	36
	Dry Lubricant/Release Agent		➔ GRAPHITE RELEASE SPRAY	36
<b>Greases</b>	Top-Line Performance Grease	>800Kg 4-ball weld	➔ AMBERGREASE EXL	36
	Food Processing Safe®: Hi-Load	400Kg 4-ball weld	➔ HI-LOAD LUBE FG	38
	Food Processing Safe®: General Purpose	200Kg 4-ball weld	➔ AMBERGREASE FG1	37
	Food Processing Safe®: High Temp	180Kg 4-Ball weld	➔ AMBERGREASE FG2	37
	Food Processing Safe®: General Purpose	120Kg 4-Ball weld	➔ AMBERGREASE FG3	37
			➔ FOOD GREASE FG	38
	Food Processing Safe®: Can Seaming Grease		➔ AMBERGREASE FG4	37
	Electronics Grease	Silicone	➔ AMBERGREASE SIL	38
		XG-250	➔ AMS4	39
	General Automotive Grease		➔ WHITE SPRAY GREASE	38
	NLGI 00		➔ WIRE ROPE LUBE	35
<b>Anti-Seize &amp; Penetrating Oils</b>	General Purpose Anti-Seize		➔ COPPER ANTI-SEIZE	34
	Food Grade Anti-Seize		➔ ASSEMBLY PASTE FG	34
	Traditional, Penetrating Oil (with MoS <sub>2</sub> )		➔ PENETRATING OIL	31
		Food Processing Safe®	➔ PENETRATING OIL FG	31
	Freeze Shock Penetrating Oil		➔ RUST FLASH	32
<b>Chains, Gears, Wire Rope, Drive &amp; Belt Lubricants</b>	Heavy Duty Chain Lubricant	MoS <sub>2</sub>	➔ CHAINSPRAY	34
		Fork Lift Trucks	➔ FLT CHAIN SPRAY	34
		Food Processing Safe®	➔ CHAIN LUBE FG	35
		High Temp.	➔ HIGH TEMPERATURE LUBRICATING OIL FG	35
	Open Gears & Drives		➔ GEAR & WIRE ROPE LUBE	34
	Wire Ropes	Aerosol	➔ GEAR & WIRE ROPE LUBE	34
		Bulk Grease	➔ WIRE ROBE LUBRICANT	35
	Drive Belts & Conveyors		➔ BELT DRESSING FG	35
<b>Bulk Oils</b>	Synthetic		➔ GEAR OIL SUPER 320 FG	40
			➔ GEAR OIL SUPER 220 FG	40
			➔ GEAR OIL SUPER 150 FG	40
			➔ HYDRAULIC OIL SUPER 68 FG	40
			➔ HYDRAULIC OIL SUPER 46 FG	40
			➔ HYDRAULIC OIL SUPER 32 FG	40
	Semi-Synthetic		➔ LUBRICATING OIL 'LO' 100	41
			➔ LUBRICATING OIL 'LO' 68	41
			➔ LUBRICATING OIL 'LO' 32	41
	Mineral		➔ MULTI-OIL 46 FG	41
			➔ MULTI-OIL 32 FG	41
	Silicone		➔ SILICONE OIL	39



## 40+

### THE COMPLETE MAINTENANCE TREATMENT

A true multi-purpose 'cure-all' for engineers: use as a dewatering fluid, a penetrant on seized fasteners, a general lubricant, and as a corrosion inhibitor.

- Excellent water displacement performance
- High dielectric strength, non-conductive film
- Safe on most paints, plastics, rubbers, and all metals
- Operational temperature range: -20°C to +115°C



- 32400
- 31635
- 31712

- 31563
- 31711



- MATERIALS COMPATIBILITY
- LUBRICITY
- TEMP. RESISTANCE
- FILM VISCOSITY



## AGL 1

### LUBRICANT FOR ELECTRICAL EQUIPMENT

Use to displace moisture and protect electrical contacts from corrosion.

- Ideal for renovating water-damaged equipment and motors
- Provides precision lubrication with its thin, high dielectric strength lubricating film
- Prevents electronic malfunction due to humidity, condensation or corrosion
- Displaces water, lubricates and protects



- 31567

- 32597



- MATERIALS COMPATIBILITY
- LUBRICITY
- TEMP. RESISTANCE
- FILM VISCOSITY



## PX24

### MILITARY GRADE PROTECTIVE LUBRICANT

Exceptional multi-purpose lubricant formulated to military specifications. It offers excellent materials compatibility, good lubrication as a machine oil, total moisture displacement and medium-term corrosion protection.

- Meets military specification Def. Stan 68-10 Issue 5 PX24
- Zero copper corrosion: IP 154, max 1: no pitting or etching
- Operational temperature range: -20°C to +115°C
- Rolls Royce Aerospace Approved: 1042E
- AgustaWestland approved: WHPS: 158
- Fitted with a 360° Spray System for all angle use



- 31565
- 31705
- 31707

- 31974
- 31706



- MATERIALS COMPATIBILITY
- LUBRICITY
- TEMP. RESISTANCE
- FILM VISCOSITY



## MOISTURE REMOVER FG

### NSF REGISTERED DEWATERING FLUID

For use on equipment to displace moisture, particularly after wash-down. Ideal for use on electronics.

- NSF H2 registered (No.142299)
- Prevents corrosion by displacing water from affected areas
- Operational Temperature range: -50°C to +120°C



- 30260



- MATERIALS COMPATIBILITY
- LUBRICITY
- TEMP. RESISTANCE
- FILM VISCOSITY



## MACHINE OIL FG

### NSF H1 GENERAL PURPOSE LUBRICANT

For use in the food industry as a highly effective metal-to-metal lubricating film.

- NSF H1 registered (No.137999 & 140249)
- Formulated using only food grade acceptable components
- Creates a highly effective lubricating and anti-friction film
- Can be used as an anti-corrosion coating for metal parts in high humidity conditions
- Operational temperature range: -18°C to +120°C

MATERIALS COMPATIBILITY

LUBRICITY

TEMP. RESISTANCE

FILM VISCOSITY



## MULTI-LUBE

### MULTI-PURPOSE LUBRICANT

A versatile light lubricant for use by automotive professionals and for the maintenance of mechanical handling equipment.

- Use as a lubricant, penetrant, anti-corrosion spray or dewatering fluid
- Safe on most paints, plastics, rubbers, and all metals
- Operational temperature range: -20°C to +115°C
- Good water displacement properties

MATERIALS COMPATIBILITY

LUBRICITY

TEMP. RESISTANCE

FILM VISCOSITY



## PENETRATING OIL

### PENETRANT FOR SEIZED PARTS

Use as a highly effective release agent for all types of seized fasteners.

- Quickly frees fasteners seized by corrosion, heat, and over-tightening
- Lubricates fine and close tolerance threads
- Contains MoS<sub>2</sub>
- Facilitates easier disassembly & reassembly
- Softens rust and carbon deposits
- Exceptionally low surface tension lubricant

MATERIALS COMPATIBILITY

LUBRICITY

TEMP. RESISTANCE

FILM VISCOSITY



## PENETRATING OIL FG

### FOOD GRADE PENETRATING OIL

For use in the food & beverage industry on fasteners seized by heat, corrosion, over-tightening and contamination.

- NSF H1 registered (No.140260)
- Spray on, allow to penetrate, and remove seized fasteners without damaging the head, thread or risk shearing
- Does not contain silicone
- Safe for use on all metals

MATERIALS COMPATIBILITY

LUBRICITY

TEMP. RESISTANCE

FILM VISCOSITY





## RUST FLASH

### PENETRANT WITH FREEZE SHOCK ACTION

For use on all seized and corroded fasteners. Ideal for bolts on equipment located outside and subjected to adverse conditions.

- Utilises the laws of thermo-dynamics: A 10 second burst will shock rust down to -40°C
- The rapid temperature drop causes the rust to fracture, allowing the lubricating oils to penetrate faster
- Ideal in automotive applications also frees corroded exhaust clamps

MATERIALS COMPATIBILITY

LUBRICITY

TEMP. RESISTANCE

FILM VISCOSITY



31578



## SILICONE LUBRICANT

### GENERAL PURPOSE SILICONE LUBRICANT

Use for plastic-to-plastic lubrication and as a highly effective friction inhibitor on chutes and slides. Ideal for use on tight plastic pipe fittings, or as a cutting aid on paper/textile blades.

- Odourless, colourless and non-staining
- Non-toxic and safe for use with potable water systems
- Exhibits excellent slip properties on blades, tables, chutes and conveyor guides
- Operational temperature range: -50°C to +200°C
- WRAS approved product: 1310510

MATERIALS COMPATIBILITY

LUBRICITY

TEMP. RESISTANCE

FILM VISCOSITY



31631



WRAS APPROVED PRODUCT



## SILICONE ANTI-STICK

### CONCENTRATED SILICONE LUBRICANT

High concentration silicone lubricant for demanding applications with higher loads or increased speeds e.g. robotic picking lines, pallet conveyors guides, and close tolerance fitting of large bore water pipes.

- Odourless, colourless and non-staining
- Use where high standards of purity and performance are essential
- Helps prevent line jams and inhibits adhesive build up on blades and sealers
- Operational temperature range: -50°C to +200°C
- WRAS approved product: 1310510

MATERIALS COMPATIBILITY

LUBRICITY

TEMP. RESISTANCE

FILM VISCOSITY



31572



WRAS APPROVED PRODUCT



## SILICONE FG

### NSF H1 REGISTERED SILICONE LUBRICANT

Use where friction reduction is required particularly plastic-to-plastic components, on guide rails or as a label adhesive anti-stick treatment to dramatically reduce label adhesive build-up.

- NSF H1 registered (No.138000)
- Excellent general lubrication with a relatively dry film
- Eliminates sticking, squeaking and binding
- Operational temperature range: -40°C to +200°C
- Use on high-speed bagging lines and on chutes/slides
- Dry film ensures no product contamination

MATERIALS COMPATIBILITY

LUBRICITY

TEMP. RESISTANCE

FILM VISCOSITY



30248







## AMBERGLIDE

### CONCENTRATED PTFE LUBRICANT

A general purpose lubricating oil fortified with high levels of PTFE for exceptional lubrication and anti-friction properties.

- Provides a long-lasting and durable film
- Significantly increases re-lubrication intervals
- Operational Temperature range: -10°C to +180°C
- Highly water resistant and repels water from treated areas

MATERIALS COMPATIBILITY

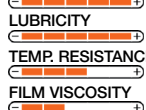

31571



## DRY FILM ANTI-STICK

### CONCENTRATED DRY PTFE LUBRICANT

A concentrated, high PTFE content dry film lubricant for the lubrication of moving parts where an oily/wet or silicone lubricant cannot be used.

- The high level of PTFE in the dry film provides excellent anti-friction and slip performance to all sliding surfaces
- Excellent materials compatibility
- Suitable for use as an anti-tracking agent
- The dry film is unaffected by oil or solvents
- Operational Temperature range: -100°C to +200°C

MATERIALS COMPATIBILITY

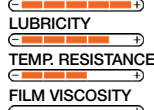

31573



## DRY PTFE LUBE FG

### NSF H1 REGISTERED DRY LUBRICANT

A fine, dry PTFE lubricant for the general lubrication of moving parts where an oily or silicone lubricant cannot be used.

- NSF H1 registered (No.139899)
- Excellent materials compatibility
- Deposits a dry, non-staining film of pure PTFE
- The dry film is unaffected by oil and solvents
- Operational Temperature range: -100°C to +200°C

MATERIALS COMPATIBILITY

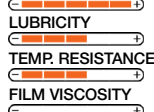

31589



## DRY MOLY

### DRY MOLYBDENUM DISULPHIDE LUBRICANT

For use in high load applications where other lubricants would fail, but a dry film is still required. Use as a running in treatment on rolling and sliding bearings.

- Tough and long lasting resin bonded lubricant
- Multiple applications (re-coating) provides enhanced performance, with the final coat benefiting from light polishing to further improve slip.
- Operational Temperature range: -150°C to +400°C

MATERIALS COMPATIBILITY

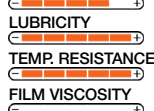

31576





## COPPER ANTI-SEIZE PASTE

### HIGH TEMPERATURE ANTI-SEIZE

Use on threaded fasteners to prevent seizing during prolonged maintenance intervals, in hostile/high humidity environments, and areas subjected to high temperatures.

- Formulated with micronized copper and anti-oxidant additives to reduce friction and wear. Lead & Nickel free
- Good corrosion protection even in highly corrosive environments
- True copper paste exhibits much higher copper content than equivalent copper greases
- Operational Temperature range: -30°C to +1100°C



MATERIALS COMPATIBILITY  
LUBRICITY  
TEMP. RESISTANCE  
FILM VISCOSITY



## ASSEMBLY PASTE FG

### ANTI-SEIZE & ASSEMBLY COMPOUND

Use in the same manner as a traditional Copper Anti-Seize on fasteners, or as a running-in compound for bearings. The non-metallic solids content make this product suitable for use in the food industry.

- NSF H1 registered (No.138266 & 139900)
- Prevents seizure of threaded components enabling easy and quick dismantling
- Operational Temperature range: -30°C to +1100°C



MATERIALS COMPATIBILITY  
LUBRICITY  
TEMP. RESISTANCE  
FILM VISCOSITY



## GEAR & WIRE ROPE LUBRICANT

### HEAVY DUTY LUBRICANT

Specially formulated for open gears in dusty environments (e.g. quarries) where the semi-dry film does not attract or hold dust. Use on all wire ropes subjected to tension and/or movement.

- Forms a semi-dry, non-peeling film that overcomes the limitations of grease and pressure cushions
- Can be applied to gears in motion
- Deep penetration of wire ropes for internal lubrication and corrosion protection
- Operational Temperature range: -25°C to +100°C



MATERIALS COMPATIBILITY  
LUBRICITY  
TEMP. RESISTANCE  
FILM VISCOSITY



## CHAINSPRAY

### CHAIN & DRIVE LUBRICANT

Use on all types of drive chains, including production line, door mechanisms, quarry plant, and drying oven doors.

- Offers maximum adhesion to chain link with excellent penetration, lubrication and corrosion protection of the pins
- High temperature resistant: up to 200°C continuous (300°C intermittent)
- Also available as an alternative product specifically for use on fork lift trucks: "FLT Chain Spray"



MATERIALS COMPATIBILITY  
LUBRICITY  
TEMP. RESISTANCE  
FILM VISCOSITY





## CHAIN LUBE FG

### FOOD GRADE PTFE CHAIN LUBRICANT

Ideal for all types of chains and chain driven drive systems. The addition of PTFE to the lubricant enhances long-term chain lubrication.

- NSF H1 registered (No.137998 & 143144)
- Gentle foaming action helps lubricant cling to chains and penetrate deep into links
- Leaves a tenacious, long lasting lubricating and anti-corrosion film
- Operational Temperature range: -15°C to +175°C

MATERIALS COMPATIBILITY

LUBRICITY	██████████
TEMP. RESISTANCE	██████████
FILM VISCOSITY	██████████



## HIGH TEMPERATURE LUBRICATING OIL FG

### FOOD GRADE HIGH TEMPERATURE OIL

Formulated for use on high temperature bakery chains within the food & beverage sector, this advanced, fully-synthetic lubricating oil can be used for general lubrication where an NSF registered H1 oil is preferred and high temperatures are normal.

- NSF H1 registered
- Operational temperature range: 0°C to 280°C
- Non-tainting, non-carbonising, low-fuming oil
- Excellent penetration of chain links and pins
- Excellent anti-wear and anti-corrosion performance

MATERIALS COMPATIBILITY

LUBRICITY	██████████
TEMP. RESISTANCE	██████████
FILM VISCOSITY	██████████



## WIRE ROPE LUBRICANT

### SEMI-FLUID WIRE ROPE GREASE

Designed for the lubrication and corrosion prevention requirements of wire ropes working under all conditions, particularly marine environments.

- Penetrates between the rope strands to provide internal lubrication and protection
- High solids content protects wire rope strands from high load and wear during service life
- NLGI grade 00

MATERIALS COMPATIBILITY

LUBRICITY	██████████
TEMP. RESISTANCE	██████████
FILM VISCOSITY	██████████



## BELT DRESSING FG

### ADHESIVE BELT LUBRICANT

Improves grip on all types of belts whilst reducing squeak and prolongs belt service life.

- NSF H1 registered (No.140257)
- Works on all types of belts: vee, flat, toothed, rubber, leather and fabric
- Protects belt from deterioration through oxidation and heat
- Tacky lubricating film increases belt pulling power and does not fling off

MATERIALS COMPATIBILITY

LUBRICITY	██████████
TEMP. RESISTANCE	██████████
FILM VISCOSITY	██████████





## BLUE ADHESIVE LUBRICANT

### ADVANCED MULTI-PURPOSE LUBRICANT

A specially formulated blend of high quality mineral and synthetic oils, anti-oxidation and anti-wear additives, friction modifiers and tackiness agents.

- Penetrates upon application then thickens
- Ideal for applications where shock loading occurs
- Highly visible blue colour upon application for visible coverage, which then turns transparent after a few days
- Temperature range: -12°C to +150°C (180°C intermittent)



32500



MATERIALS COMPATIBILITY

LUBRICITY

TEMP. RESISTANCE

FILM VISCOSITY



## GRAPHITE RELEASE SPRAY

### DRY GRAPHITE LUBRICANT & RELEASE SPRAY

A high purity, dry, concentrated graphite lubricant and release agent. Formulated especially for the glass blowing industry as a mould pre-treatment.

- The resin binder allows the micro-graphite particles to bind strongly to all substrates
- Above 100°C the binder will safely decompose leaving dry graphite powder for the highly effective and consistent release of formed glass bottles



32499



MATERIALS COMPATIBILITY

LUBRICITY

TEMP. RESISTANCE

FILM VISCOSITY



## GRAPHITE LOCK LUBE

### DRY LUBRICANT FOR SMOOTH LOCK LUBRICATION

A dry graphite lubricant for long lasting, smooth lock operation. The microscopic grains of graphite ensure good penetration and effective anti-seize lubrication.

- Long lasting lubrication
- Dry film does not attract dirt and grime
- Excellent water resistance
- Wide operating temperature range
- Works even when lock has mild corrosion



33000



MATERIALS COMPATIBILITY

LUBRICITY

TEMP. RESISTANCE

FILM VISCOSITY



## AMBERGREASE EXL

### EXTENDED LIFE, PERFORMANCE BEARING GREASE

Use on critical, high load bearings and sliding surfaces. Ideal for use in applications where a longer than usual in-service life is required.

- Exceptional load carrying capacity: >800Kg 4-ball weld load
- Mean Hertz Load: 125Kg; Timken OK load: 25Kg
- Highly visible red grease, NLGI type 2, Lithium-Calcium Complex thickened
- Operational Temperature range: -30°C to +150°C



30304

31574



MATERIALS COMPATIBILITY

4-BALL WELD

TEMP. RESISTANCE

NLGI GRADE



## AMBERGREASE FG1

### FOOD GRADE HIGH PERFORMANCE GREASE

A high performance multi-purpose grease suitable for all bearing types and use at low temperatures. It demonstrates enhanced performance characteristics in moist or wet environments.

- NSF H1 Registered (No.138264)
- White, NLGI type 2, aluminium complex thickened grease
- Very good load performance: 4-ball weld load >200Kg
- Very low water-washout <1%
- Operational Temperature range: -50°C to +165°C



MATERIALS COMPATIBILITY

- 4-BALL WELD
- TEMP. RESISTANCE
- NLGI GRADE



31584

18kg 32451



## AMBERGREASE FG2

### HIGH TEMPERATURE BEARING GREASE

For use in the food/beverage industry on all types of plain bearings subjected to elevated temperatures such as on oven conveyors, oven fan bearings, bakery lines, autoclaves, and food container moulding machines.

- NSF H1 registered (No.138265)
- Translucent NLGI type 2 silicone grease
- Shell 4-ball weld load (IP 239): 180Kg
- Operational Temperature range: -20°C to +220°C



MATERIALS COMPATIBILITY

- 4-BALL WELD
- TEMP. RESISTANCE
- NLGI GRADE



31585



## AMBERGREASE FG3

### NSF H1 MULTI-PURPOSE BEARING GREASE

A multi-purpose grease that is ideally suited to general bearing lubrication not subjected to extremes of operating requirements.

- NSF H1 registered (No.140248)
- Translucent NLGI type 2 grease; aluminium complex thickened
- Ideal for end-of-line conveyor lubrication and low-load drive motor bearings
- Operational Temperature range: -20°C to +140°C



MATERIALS COMPATIBILITY

- 4-BALL WELD
- TEMP. RESISTANCE
- NLGI GRADE



30258



## AMBERGREASE FG4

### NSF H1 SEMI-FLUID GREASE

Formulated as a multi-purpose food grade grease based on PAO, enhanced with PTFE. Particularly suitable for use as a can seaming grease for automatic application systems.

- NSF H1 registered (No.151552)
- White, NLGI type 0, aluminium complex thickened grease
- 4-ball weld load: 400Kg
- Resistant to water wash-off
- Operational Temperature range: -50°C to +165°C



MATERIALS COMPATIBILITY

- 4-BALL WELD
- TEMP. RESISTANCE
- NLGI GRADE



18kg 32547





## HI-LOAD LUBE FG

### NSF H1 HEAVY DUTY BEARING GREASE

Use on heavily loaded bearings and sliding surfaces (e.g. guide rails) to minimise friction and wear.

- NSF H1 registered (No.143048)
- Excellent load-bearing: 4-ball weld load >400Kg
- Excellent moisture resistance with very low water washout
- NLGI type 2, white, aluminium complex thickened grease
- Operational Temperature range: -40°C to +180°C
- Available in 18Kg as "Grease EP2"

MATERIALS COMPATIBILITY

- 4-BALL WELD
- TEMP. RESISTANCE
- NLGI GRADE



## FOOD GREASE FG

### MULTI-PURPOSE SPRAY GREASE

Formulated for use in the food and beverage industry on plain bearings, hinges and moving parts. Particularly for limited access areas where regular grease penetration may be difficult.

- NSF H1 registered (No.140258)
- NLGI type 2 white grease, aluminium complex thickened
- Excellent resistance to moisture with very low water wash-out
- Operational Temperature range: -20°C to +140°C

MATERIALS COMPATIBILITY

- 4-BALL WELD
- TEMP. RESISTANCE
- NLGI GRADE



## WHITE SPRAY GREASE

### MULTI-PURPOSE SPRAY GREASE

Ideal for use on vehicle door hinges, on runners, guides, and for assembly of close tolerance parts.

- Multi-purpose white grease in an aerosol
- Good penetration for even coverage and protection
- Operational Temperature range: -10°C to +120°C

MATERIALS COMPATIBILITY

- LUBRICITY
- TEMP. RESISTANCE
- FILM VISCOSITY



## AMBERGREASE SIL

### PURE SILICONE GREASE

Ideal for electric motor spindle lubrication or to protect electronics from atmospheric moisture.

- Clear, colourless, odourless NLGI type 2 grease
- Suitable for waterproofing all types of electrical systems
- Excellent dielectric resistance
- 4-ball weld load of 200Kg
- Operational Temperature range: -50°C to +220°C

MATERIALS COMPATIBILITY

- LUBRICITY
- TEMP. RESISTANCE
- NLGI GRADE





## AMS4 SILICONE GREASE

### MILITARY GRADE SILICONE GREASE

Military & aviation grade XG250 silicone grease for use on rubber seals to prevent cracking, on 3-phase connectors to prevent moisture ingress and for general lubrication.

- Insulates high voltage parts against leaking and arcing
- Waterproofs electronics in damp or humid conditions
- Meets military and aviation specifications: Def. Stan 68-69/1



31566



MATERIALS COMPATIBILITY

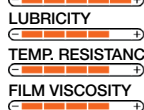

## 3H OIL FG

### FOOD CONTACT OIL

3H Oil FG is a lubricating and release oil that can be used in applications where direct food contact is likely or certain. The light oil can be used as an anti-corrosion treatment on metal surfaces, tools, and equipment, as a release agent on bakery tins & moulds or as a light lubricant for mixing blades.

- NSF 3H & H1 registered (No.148343)
- Light oil seals out moisture and helps prevent corrosion
- Non-tainting, non-staining and clear
- Operational temperature range: -5°C to +120°C



32326



MATERIALS COMPATIBILITY



## SILICONE OIL

### PURE SILICONE OIL

A clear, odourless, pure silicone oil for a wide range of anti-stick and anti-friction applications where a highly concentrated silicone oil is required.

- Pure silicone oil with a viscosity of 100 Cst
- Non-flammable, non-toxic, and chemically stable
- Odourless, colourless and non-staining
- Safe on most paints, plastics, rubbers, and all metals
- Exhibits excellent slip properties
- Operational Temperature range: -40°C to +200°C



31717



MATERIALS COMPATIBILITY



## HYDRAULIC OIL SUPER 32/46/68 FG



A series of transparent, odourless, fully synthetic hydraulic fluids based on Poly Alpha Olefins (PAO) for use in the food & beverage sector. These oils have extremely stable operating characteristics with a wide temperature range, foaming suppression, friction/wear reduction, and moisture rejection. Passes DIN 51524/T2 standard for hydraulic fluids. Can be used as a compressor oil (ISO 32).



### Hydraulic Oil Super 32 FG

NSF H1 registered: No.142717

Viscosity @ 40°C: ISO 32

Temperature Stability: Viscosity Index: 142

Temperature Range: -57°C to +238°C



30265



30266

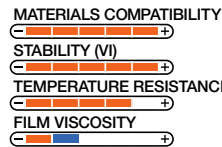

### Hydraulic Oil Super 46 FG

No.142716

ISO 46

Viscosity Index: 145

-57°C to +252°C



30267



30268

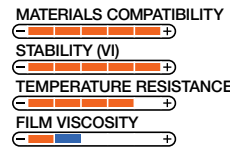

### Hydraulic Oil Super 68 FG

No.142714

ISO 68

Viscosity Index: 141

-57°C to +260°C



30270



30271

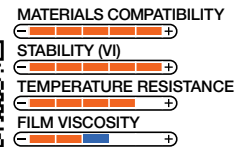

## GEAR OIL SUPER 150/220/320 FG



A series of transparent, odourless, fully synthetic gear oils based on Poly Alpha Olefins (PAO) with a complex performance additive package for use in the food & beverage sector. These oils have extremely stable operating characteristics with a wide temperature range, foaming suppression, excellent friction/wear reduction (even highly loaded gears), and moisture rejection.

These gear oils provide high EP and anti-wear performance, meet the DIN 51 517 standard, and exhibit extremely wide temperature range stability. Ideal for gear boxes with extended service intervals.



### Gear Oil Super 150 FG

NSF H1 registered: No.142715

Viscosity @ 40°C: ISO 150

Temperature Stability: Viscosity Index: 137

Temperature Range: -56°C to +256°C



30272



30273

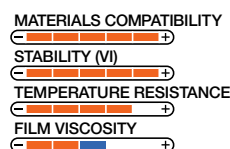

### Gear Oil Super 220 FG

No.142721

ISO 220

Viscosity Index: 140

-51°C to +258°C



30274



30275

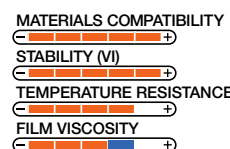

### Gear Oil Super 320 FG

No.142720

ISO 320

Viscosity Index: 142

-48°C to +264°C



30276



30277

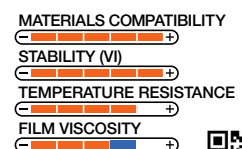





General purpose highly refined white oils for use in multiple applications such as in selected hydraulic systems, as a medium viscosity lubricating film and as a light duty anti-corrosion coating.

	Multi Oil 32 FG	Multi Oil 46 FG
NSF H1 Reg:	No.142719	No.142718
Viscosity @ 40°C:	ISO 32	ISO 46
Viscosity Index:	105	105
Temperature range:	-21°C to +170°C	-21°C to +180°C

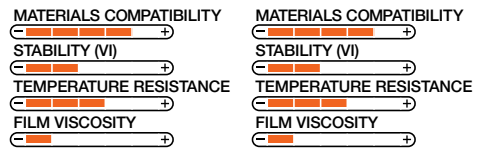

# LUBRICATING OIL 'LO' 32/68/100



A multi-purpose, semi-synthetic lubricating oil for the food and drink industry. NSF H1 registered for use where incidental food contact may occur. This oil is formulated with highly refined medicinal oils and special additives. It can be used as a hydraulic oil, a compressor oil, a general lubricating oil or as a light anti-corrosion coating.

	LO 32 FG	LO 68 FG	LO 100 FG
NSF H1 Reg:	No.143789	No.143794	No.143788
Viscosity @ 40°C:	ISO 32	ISO 68	ISO 100
Viscosity Index:	105	105	105
Temperature range:	-21°C to +170°C	-21°C to +200°C	-18°C to +215°C

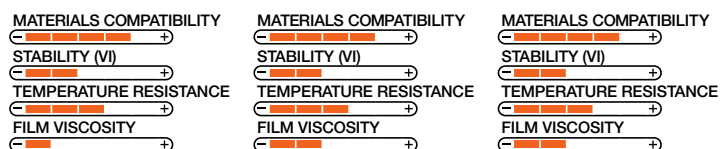

# METAL WORKING

Created for the most demanding metal working applications where 'right first time' results are required

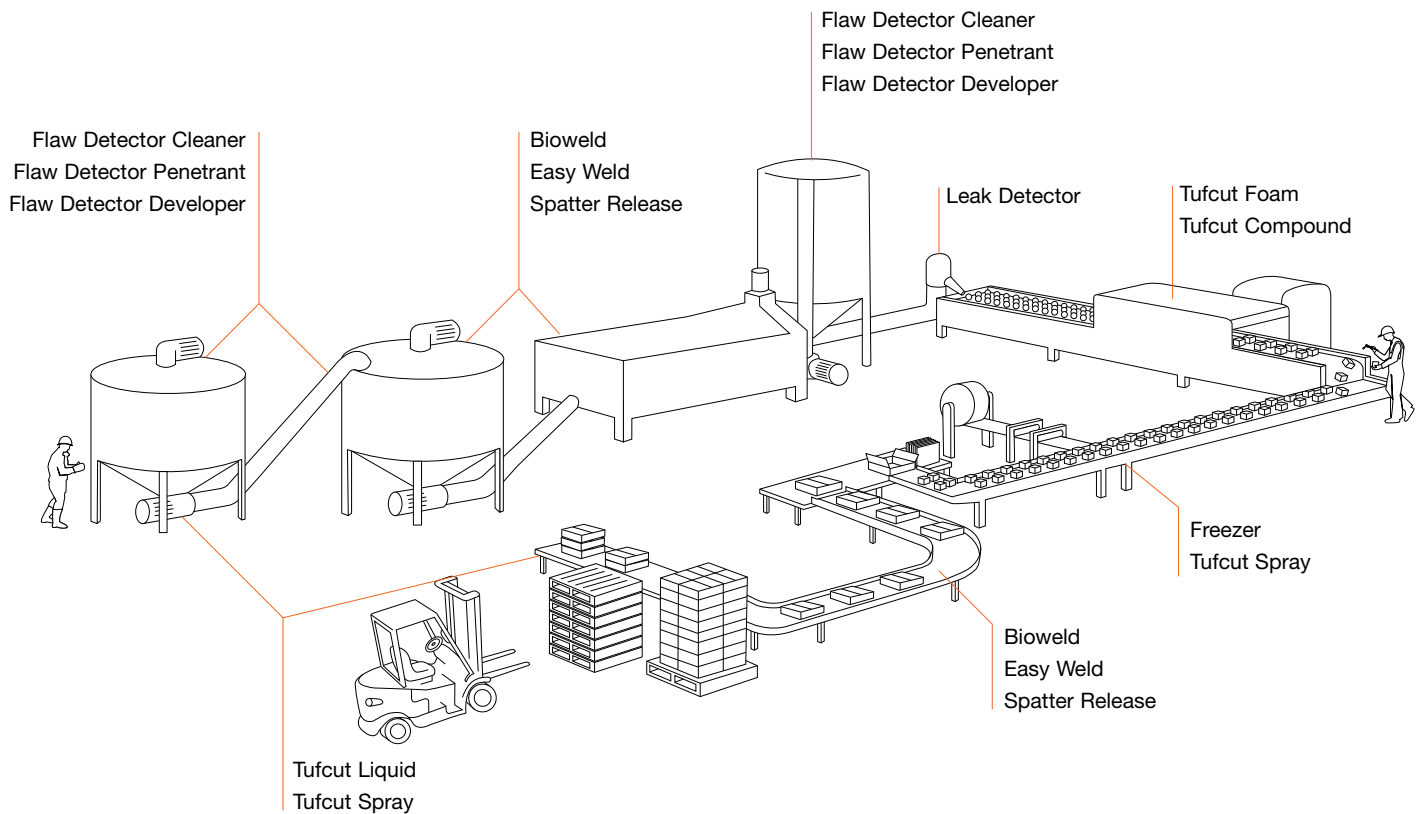

# Metal Working Selection Chart

Product Type	Application Requirement	Type of Duty	Recommended Product	Page	
Metal Working	CNC & Automated Equipment		TUFCUT AQUA	43	
	High Carbon Steels & 'Tough' Metal		TUFCUT SPRAY	43	
		Foaming	TUFCUT FOAM	43	
		Traditional Liquid	TUFCUT LIQUID	43	
	Titanium		TUFCUT FOAM	43	
	Aluminium & 'Soft' Metals		TUFCUT SPRAY	43	
		Foaming	TUFCUT FOAM	43	
		Traditional Liquid	TUFCUT LIQUID	43	
		Thick Paste	TUFCUT COMPOUND	43	
	Composites (e.g. Carbon Fibre) (Food Processing Safe®)		TUFCUT LIQUID	43	
		TUFCUT SPRAY	43		
Welding	Anti-Spatter	Traditional	SPATTER RELEASE	44	
		Solvent Based	Biodegradable	EASY WELD	44
			Water Based	BIOWELD	44
		Flaw Detection	Dye Penetrant System	FLAW DETECTORS	45
Leak Detection	LEAK DETECTOR		44		

## TUFCUT: LIQUID / SPRAY / FOAM / COMPOUND / AQUA

Tufcut is a range of specialist metal cutting lubricants based on a mixture of lubricants, extreme pressure additives, and anti-oxidants. The range has been formulated to offer instant, ready to use metal machining products that demonstrate exceptional performance in demanding applications.



**Tufcut Liquid**  
Metal Cutting Lubricant

- Original Tufcut liquid
- Improves heat dissipation prevents chip welding
- Approved by AgustaWestland for machining composite materials (LIS 6045)

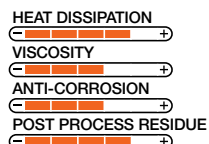

**Tufcut Spray**  
Metal Cutting Lubricant

- The original Tufcut liquid, in an aerosol
- Allows heavier close tolerance cuts
- Improves heat dissipation and prevents chip welding
- NSF H2 Registered

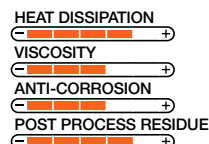

**Tufcut Foam**  
Foaming Metal Cutting Lubricant

- Proven Tufcut liquid in a foam that clings to vertical surfaces
- Ideal for maintenance of turbine blades
- Minimal smoking & fumes in use

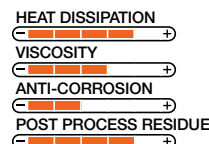

**Tufcut Compound**  
Metal Cutting Lubricant

- A traditional metal cutting paste that has all the performance of Tufcut liquid, in a paste
- Pleasant mild pine fragrance
- Ready to use straight from the tin

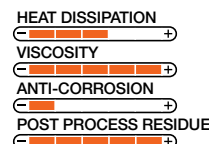

**Tufcut Aqua**  
Water soluble, Semi-Synthetic Cutting Fluid

- A premium quality, multi-purpose cutting fluid for use in automated applications
- Transparent - allows operators to see work-piece
- Contains cleaning and degreasing surfactants

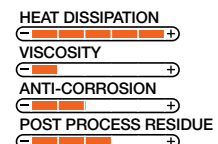



## SPATTER RELEASE

### NON-FLAMMABLE WELD ANTI-SPATTER

Traditional solvent based spatter release for all welding applications.

- Prevents spatter adhesion to welding equipment, work pieces, surfaces, jigs, and surrounding areas
- Non-Flammable
- Does not affect post-welding operations
- No silicone
- Anti-spatter film is easily wiped away



31620



## BIOWELD

### WATER BASED WELD SPATTER RELEASE AGENT

A water based spatter release agent which gives exceptional results without the use of harmful solvents, silicones or mineral oils.

- Odourless, non-flammable and safe in use
- Fine spray pattern for excellent coverage
- Does not contain silicone or solvents
- Contains a highly effective flash-rust inhibitor
- Automotive approval: Ford Tox No.: 163241

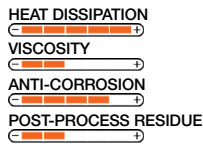

31621

31727 (670B)

31726 (670B)

31728 (670B)



## EASY WELD

### BIODEGRADABLE ANTI-SPATTER

Easy Weld provides a quick, easy way to prevent the adherence of spatter to metal surfaces and eliminates the requirement for chiselling, grinding or extensive wire brushing after welding.

- Non-silicone heat resistant barrier
- Easy removal of spatter
- Economical in use due to thin film performance
- Based on biodegradable oil
- Keeps treated nozzles and equipment clear from spatter build-up

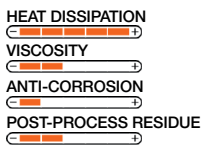

30287



## LEAK DETECTOR

### WATER BASED GAS LEAK DETECTOR

Highly visible and easy to use gas leak detector for pipe and joints. Ideal for HVAC installations.

- Water-based formulation with no oils, silicone, solvents and no 'run-off' hazards
- Non-flammable and odourless
- Oxygen system safe
- Meets BS EN 14291:2004, and can be used for VOSA MOT testing

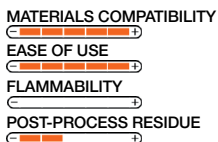

31633

31781





## FLAW DETECTORS: CLEANER



### SOLVENT CLEANER FOR PREPARATION

A fast drying cleaner for the removal of all kinds of contaminants on the surface to be inspected. Serves as a preparation of the surface before inspection with dye penetrant.

- Rapid dry, solvent cleaner
- Leave surfaces clean & dry
- Removes contamination including; metal working fluid, anti-corrosion coatings, oil & grime



30288



MATERIALS COMPATIBILITY  
EASE OF USE  
FLAMMABILITY  
POST-PROCESS RESIDUE



## FLAW DETECTORS: PENETRANT



### DYE PENETRANT FOR FLAW IDENTIFICATION

Red coloured, water washable penetrant for non-destructive testing of metal surfaces. The penetrant wicks into tiny flaws within 10 minutes. Excess penetrant should be removed before using the developer.

- Highly visible red dye
- Wicks in to defects down to 20µm
- Very easy to use & cost effective



30289



MATERIALS COMPATIBILITY  
EASE OF USE  
FLAMMABILITY  
POST-PROCESS RESIDUE



## FLAW DETECTORS: DEVELOPER



### HIGH CONTRAST POWDER DEVELOPER

Enhances and makes each trace of Penetrant visible once applied and left for at least 7 minutes. Post cleaning of the inspected area can be done with the Cleaner.

- High contrast and easy to use
- Identifies defects as small as 20µm
- Easily removed with the 'cleaner'



30290



MATERIALS COMPATIBILITY  
EASE OF USE  
FLAMMABILITY  
POST-PROCESS RESIDUE

## HOW TO USE THE FLAW DETECTOR RANGE



1. The area to be checked must be thoroughly cleaned. Liberally apply Flaw Detector Cleaner, allow to dry.
2. Spray a light, even film of penetrant on surface. Allow to penetrate for 10 to 20 minutes.
3. Wipe excess Penetrant off with a lint-free cloth dampened with Flaw Detector Cleaner. Allow cleaner to evaporate.
4. Shake the can of Developer thoroughly prior to use. Apply a light, homogeneous coating from a distance of about 20cm. Avoid any excess as it may mask the finest flaws. Allow to develop for at least 7 minutes.
5. Defects appear as red spots or lines on a white background. The speed of appearance, the shape and dimensions can give information on the nature of the defects. If necessary, clean the test area with Flaw Detector Developer.

# ANTI-CORROSION & PAINTS

Superior coatings for metal that prevent corrosion and allow aesthetic repair of damaged surfaces

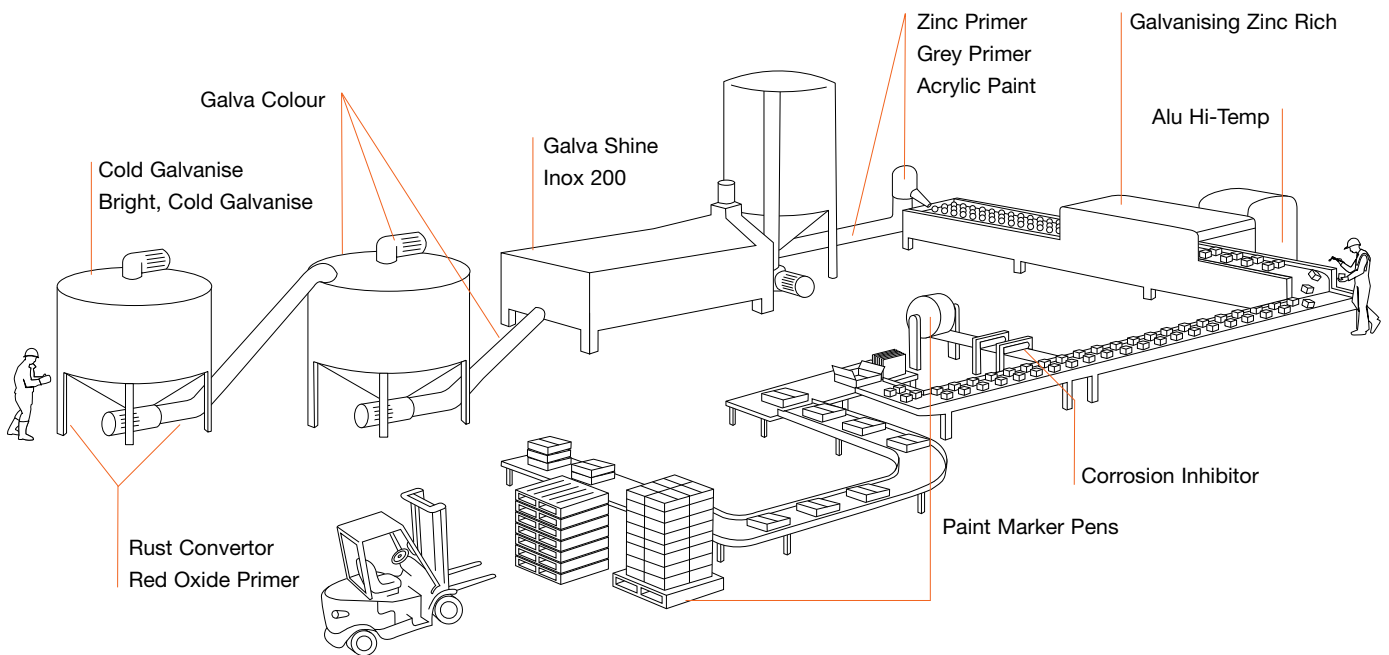

# Anti-Corrosion & Paints Selection Chart

Product Type	Application Requirement	Type of Duty	Recommended Product	Page		
Anti-Corrosion	Maximum Protection	Cathodic	COLD GALVANISE	48		
		Passivating	RUST CONVERTER	50		
		Weathers Naturally	BRIGHT, COLD GALVANISE	48		
		Stainless Steel	INOX 200	49		
	Paint		Direct To Rust	GALVA COLOUR	50	
			Aesthetic Repair	ACRYLIC PAINT	47	
			Long-Lasting Shine/Alu Alloy	GALVA SHINE	48	
			High Temperature	ALU-HI TEMP	49	
			Primer	Zinc	ZINC PRIMER	50
				Paint	GREY PRIMER	47
					RED OXIDE PRIMER	47
			Very Rapid Drying	Hammered	GALVANISING ZINC RICH	48
	Indoors/Covered		Waxy Coating (Long-Term)	CORROSION INHIBITOR	49	
			Oil Film (Short-Term)	40+	30	
			Oil Film (Medium-Term)	PX24	30	
Battery Terminals			BATTERY TERMINAL PROTECTOR	49		
Paint Pens				Standard	MARKER PENS	51
	Solvent Free	AQUA MARKER PEN		51		

## ACRYLIC PAINT



### COLOUR MATCHED PROTECTIVE COATINGS

Vibrant acrylic paint for the repair and touch-up of painted surfaces.

- RAL matched for accurate colour matches
- Fast drying: touch dry in <5 minutes
- Once cured (24-hours) the paints have a high UV resistance
- Excellent flexibility and hardness
- Excellent adhesion to all surface types



COLOUR	RAL	CODE	COLOUR	RAL	CODE
MATT BLACK	9011	20180	BRIGHT RED	3002	20184
MATT WHITE	9010	20181	BLUE	5015	20185
GLOSS BLACK	9005	20182	BATTLESHIP GREY	7032	20186
GLOSS WHITE	9016	20183	GREEN	6002	20187
SATIN BLACK	9005	32060	BRIGHT YELLOW	1018	20188
RITTAL GREY	7035	20195	CHROME SILVER		20190
FORD BLUE	5010	20555	BELLE ORANGE	2004	20559
JCB YELLOW	1007	20556	GREY PRIMER		20189
MASSEY FERGUSSON RED	3000	20557	RED OXIDE PRIMER		32379
JOHN DEERE GREEN	6001	20558			

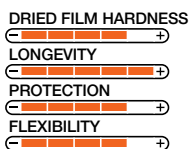

Colour squares are representative only

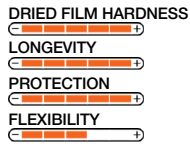

## COLD GALVANISE

### ZINC RICH PROTECTIVE COATING

Provides cathodic protection to ferrous metals. Ideal for pipes, housings, structural metal, and as a primer. Particularly suited for protecting drilled or abraded surfaces.

- Sacrificial coating protects ferrous metal from corrosion
- For use on bare, clean, non-rusted steel and seams
- Suitable for use as a renovation media: BS EN ISO 1461:1999
- >99% pure zinc at 88% concentration in the cured film for the optimal balance between protection and adhesion



30291



## BRIGHT, COLD GALVANISE

### REPAIR FOR HOT-DIP GALVANISED STEEL

Bright, Cold Galvanise goes on bright then weathers naturally for 'invisible' repairs.

- A barrier coating that protects ferrous metals from corrosion
- For use on bare, clean, non-rusted steel and seams
- Long-lasting corrosion protection
- Suitable as a top-coat for Cold Galvanise



30292



## GALVANISING ZINC RICH

### HIGH TEMPERATURE, RAPID DRYING PAINT

Use on metals subjected to intermittent high temperatures such as foundry lifting shackles, gantry arms and cranes.

- Touch dry in 15 minutes, complete cure in 24-hours
- Leaves a hammered semi-gloss finish
- The cured film can be welded through (except argon)
- Temperature range: -50°C to +550°C
- Use Amberklene FE10 fast drying solvent degreaser as the ideal surface preparation for best results



30300



## GALVA SHINE

### AESTHETIC PROTECTIVE COATING

Offers an exact colour match to architectural hybrid zinc alloy galvanised structures.

- Resists weathering, retains a super bright finish
- Adheres strongly to metal offering a long-term barrier protective coating
- Superior spray pattern ensures a blemish free, smooth finish
- Use Amberklene FE10 fast drying solvent degreaser as the ideal surface preparation for best results



30293







## CORROSION INHIBITOR

### WAXY ANTI-CORROSION TREATMENT

Use on ferrous metals as a long-term protective coating for stored equipment, or as a transportation film for trans-global component shipping.

- Film will not harden or crack
- Forms a 'self-repairing' waxy film
- Meets MIL-PRF-16173E
- Can be used as an anti-seize/anti-rust treatment for fasteners
- Will not stain or mark components

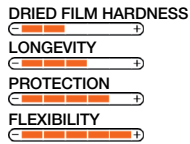

## BATTERY TERMINAL PROTECTOR

### ANTI-CORROSION TERMINAL TREATMENT

Protects battery terminals on fork lift trucks and generators from wear and corrosion and seals out moisture.

- Protective grease prevents wear to terminals through clip movement
- Highly visible dye gives an early indication of acid leakage by changing from pale yellow to red
- Viscous consistency prevents over application
- Excellent materials compatibility
- Operational temperature range: -10°C to +50°C

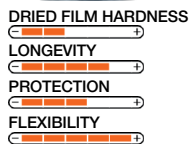

## ALU HI-TEMP

### HIGH TEMPERATURE CORROSION PROTECTION

Use on furnace doors, boiler casings, drying ovens, foundry manipulators and equipment subjected to continuous high temperatures; chimneys, flues and exhuasts.

- Protects to +600°C
- Lead and Chromate free
- Cures to a highly durable coating
- Effective barrier against corrosion

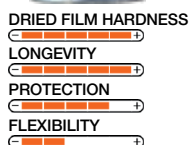

## INOX 200

### PROTECTIVE COATING FOR STAINLESS STEEL

Use on glass-pearl-blasted stainless steel as a touch-up paint.

- Touch dry in 10 minutes, complete cure 30 minutes
- Heat resistant up to +300°C
- Flexible yet hard dry film
- Contains chromium: the active corrosion inhibitor in stainless steel

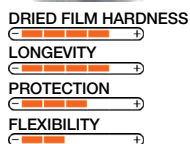



## ZINC PRIMER

### MULTI-PURPOSE METAL PRIMER

Zinc phosphate primer promotes adhesion of top-coat paint to 'difficult' substrates.

- Touch dry in 30 minutes
- Dry to over-coat in 1 hour (recommended 24-hour cure prior to over-painting)
- Best results achieved when the surface has been cleaned with Amberklene FE10 prior to application

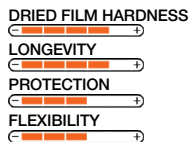

## RUST CONVERTER

### RESTORES CORRODED METAL

Passivates and binds rust to form a sound, paintable, protected surface.

- Ready to use - no dilution required
- Apply with a normal paint brush
- Non-corrosive
- Forms a durable, flexible coating
- Reduces the requirement for grinding corroded steel back to bare metal, saving time and money

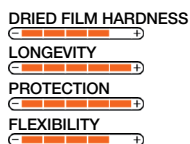

BEFORE



AFTER



## GALVA COLOUR

### 2-IN-1 ANTI-CORROSION PRIMER AND COLOUR TOP COAT

Use on surfaces which have surface rust, old paint or otherwise 'imperfect' finish.

- Reduces time spent priming and painting the top-coat: do it in one application
- RAL colours for accurate colour matches
- Free from lead, chromate and toluene
- Ideal for external pipe-line identification, railings, security fences, and storage tanks.
- Excellent coverage: up to 3m<sup>2</sup> from one 500ml can

COLOUR	RAL	CODE
	YELLOW	1004 20673
	RED	3000 20674
	BLUE	5012 20676
	BLACK	9005 20679
	SILVER	9006 20680
	WHITE	9010 20681

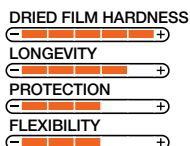

Colour squares are representative only









## MARKER PENS

### ACRYLIC PAINT MARKER PENS

Can be used for metal working/fabrication, electrical installations, civil engineering, steel stock identification, batch number marking and more.

- Tenacious resin binds paint to the surface effectively eliminating the problems associated with accidental rub off and abrasion
- Can write through water/moisture and will not wash off with water/rain
- Fast drying



COLOUR	CODE	COLOUR	CODE
 WHITE	20394	 ORANGE	20383
 GREEN	20379	 BLACK	20364
 YELLOW	20399		
 BLUE	20368		
 RED	20387		

Colour squares are representative only







## AQUA MARKER PENS

### ACRYLIC PAINT MARKER PENS

Innovative water-based paint marking pens for writing/marketing on almost any surface. Ideal for quality control, batch identification and stock control.

- Tenacious resin strongly binds paint to surface
- Excellent opacity & clear marks
- No xylene, toluene or acetone - safer in use



COLOUR	CODE
 WHITE	32493
 BLACK	32494
 YELLOW	32497
 BLUE	32496
 RED	32495

Colour squares are representative only



# ADHESIVES & SEALANTS

Essential bonding, adhesion, and gasketing products for industrial maintenance



## ADHESIVE MP 100



**MULTI-PURPOSE ADHESIVE**  
Ideal for bonding almost anything to most hard surfaces including wood and metal.

- Tack time approximately 30 seconds
- Permanent bonds
- Our best selling adhesive
- Big value 500ml fill size

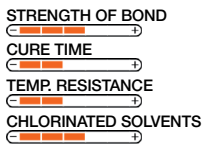

## ADHESIVE NC 500



**NON-CHLORINATED ADHESIVE**  
Use where a non-chlorinated multi-purpose adhesive is required.

- Tack time approximately 2 to 4 minutes
- Free from chlorinated solvents for improved user safety
- Variable spray pattern
- Big value 500ml fill size

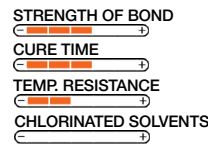

## ADHESIVE HS 300



**HIGH STRENGTH ADHESIVE**  
Use where a high strength adhesive is required e.g. warning and information signs.

- Tack time less than 10 minutes
- Free from chlorinated solvents for improved user safety
- Shear strength: >375 N per inch (25 mm2)
- Big value 500ml fill size

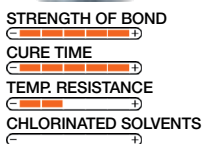

## ADHESIVE QS 900



**QUICK STICK ADHESIVE**  
Especially useful where instant grab is required to avoid slippage.

- Tack time approximately 30 seconds
- Free from chlorinated solvents for improved user safety
- Instant grab and hold
- Big value 500ml fill size

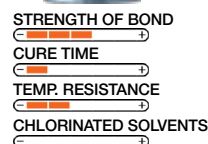

## 5024A SILICONE ADHESIVE SEALANT



### HIGH MODULUS, ACETOXY CURE SILICONE SEALANT

A ready to use one part silicone sealant suitable for use as a general purpose sealing and bonding agent. Ideal for making formed-in-place gaskets.

- Offers excellent adhesion to a wide variety of non-porous substrates such as glass, glazed ceramics, aluminium and metal
- Conforms to ISO11600
- High Modulus & Non-Slump
- Temperature resistance: -60°C to +204°C
- 310ml cartridge

	WHITE	30730
	GREY	30735
	CLEAR	31753
	BLACK	30732
	SILVER GREY	31753

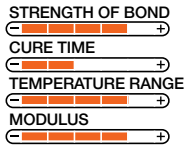

## 5005A SILICONE ADHESIVE SEALANT



### HIGH MODULUS, ACETOXY CURE SEALANT

A ready to use one-part RTV silicone sealant suitable for use as a general purpose sealing and bonding agent. Ideal for making formed-in-place gaskets.

- Excellent adhesion to a wide variety of non-porous substrates
- Maximum temperature resistance: +204°C
- Portable 75ml squeeze tube with cap
- Conforms to ISO11600
- High modulus & non-slump



31644

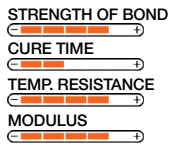

## HIGH TEMPERATURE GASKET SEALANT



### GASKET SEALANT FOR ARDUOUS CONDITIONS

A high quality, ready to use, one-part RTV gasketing sealant for the replacement of high temperature gaskets and seals.

- Touch dry in 30 minutes, full cure in 24 hours
- High modulus & non-slump
- Operational temperature range: -60°C to +260°C (+300°C intermittent)
- 310ml cartridge



31455

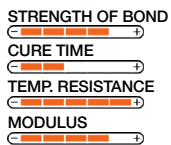

# POLYMER PROCESSING

Release agents, protectives, cleaners and compounds for all types of plastics, rubbers, and composites moulding operations

	Release Type	Processing Application	Formed Film	Active Level	Paintable	Transfer	Max. Temp.
<b>DP200</b>	Aircure Silicone Release	Multi	Dry	V.High	Yes	No	200
<b>Formula 1</b>	Silicone	Multi	Oily	High	No	Yes	200
<b>Formula 1/HT</b>	Silicone	Extrusion	Oily	High	No	Yes	300
<b>Formula 2</b>	Silicone	Rubber	Oily	Medium	No	Yes	200
<b>Formula 4</b>	Edible Veg Oil	Multi	Oily	Medium	Yes	Yes	200
<b>Formula 5</b>	Wax	Multi	Dry	Low	Yes	Yes	150
<b>Formula 6</b>	Silicone	Multi	Oily	Medium	No	Yes	200
<b>Formula 7</b>	Glycol	Multi	Wet	High	Yes	Yes	170
<b>Formula 8</b>	Silicone	Multi	Light Oily	Low	No	Yes	200
<b>Formula 10</b>	Fluoro Chemical	Thermoset	Dry	Low	Yes	Yes	180
<b>Formula 11</b>	Oil	Multi	Dry	V.Low	Yes	Minimal	150
<b>Formula 12</b>	Semi-Permanent	Multi	Dry	V.Low	Yes	No	250
<b>Formula 14</b>	Non-Silicone	Thermoplastics	Oily	High	Yes	Yes	200
<b>Formula 20</b>	Hybrid Silicone	Multi	Waxy	Medium	Yes	Minimal	150
<b>PUR 200</b>	Silicone Resin	PU	Oily	Medium	No	Yes	200
<b>PUR 400</b>	Silicone Resin	PU	Oily	Medium	No	Yes	200

# Polymer Processing Selection Chart

Product Type	Application Requirement	Characteristics	Recommended Product	Page
<b>Silicone</b>	Nylon, PP, PE	Heavy Duty	→ FORMULA 1	56
	Synthetic Fibres: Nylon	High Temp / Heavy Duty	→ FORMULA 1 HT	56
	PU	High Gloss	→ PUR 400	57
	Thermoplastics & Rubber	Medium Duty	→ FORMULA 6	56
	Non-transfer	Semi-Permanent Dry Film	→ DP 200	60
	ABS, PE, PP, PVC, PA, PU	Paintable/Post-Process OK	→ FORMULA 20	57
	Plastics & Rubber	General Purpose	→ HD-SIL RELEASE	57
	Rubber & Natural Polymers	Medium Duty	→ FORMULA 2	56
	Plastics & Rubber	Light Duty	→ FORMULA 8	56
<b>Non - Silicone</b>	Thermoplastics	Heavy Duty	→ FORMULA 7	58
	Thermoset, PU, Epoxy, PE	Dry Film	→ FORMULA 10	58
	PVC, PU & Flexible Polymers	Wet Film	→ FORMULA 4	58
	Electronic 'Grade' Polymers	Minimal Transfer	→ FORMULA 11	59
	LDPE, HDPE, PP, PVC, PS, POM, PA	Multiple Releases	→ FORMULA 14	59
	Thermoplastics	General Purpose	→ NO-SIL RELEASE	60
	Fine Details Thermoplastics	Medium Duty, Dry Film	→ FORMULA 5	58
	Synthetic Rubbers, PP, PE	Semi-Permanent	→ FORMULA 12	59
	GRP, Epoxy, PE, Rotational	Semi-Permanent	→ RELEASE 100	60
<b>Specialist</b>	General Purpose	Water Based - Silicone	→ MPR100	60
	Concentrated	Water Based - Silicone	→ MPR200	61
	Rotational Moulding	Water Based - Semi-Permanent	→ ROM300	62
	GRP, High Gloss	Wax	→ COM300	61
	Composites (inc: Boron, Amide, & Carbon)	Semi-Permanent	→ COM400	61
	Semi-Rigid & Integrated Skin PU	Solvent Based - Wax & Silicone	→ PUR101	61
	Rigid Insulation & Semi-Rigid PU	Solvent Based - Allows Post-Process Painting	→ PUR300	62
	High Gloss Elastomeric PU	Solvent Based - Wax & Silicone	→ PUR400	57
	Rubber Release	Water Based - Semi-Permanent	→ RBR100	62
	Concentrated Rubber & Silicone Rubber Release	Water Based - High Temperature	→ RBR310	62
	Ejector Pin Lubricant		→ EJECTOR PIN LUBRICANT	63
<b>Food &amp; Beverage Packaging</b>	Mould / Packaging Release (Food Contact)	Silicone	→ SILICONE RELEASE FG	57
		Non-Silicone	→ NON-SILICONE RELEASE FG	59
	Mould Tool Protection	Visible - Blue	→ BLUE MOULD PROTECTIVE FG	63
		Clear	→ CLEAR MOULD PROTECTIVE	64
	Mould / Tool & General Cleaner	Solvent	→ SOLVENT CLEANER FG	65
<b>Anti-Corrosion</b>	Short-Term Protection	Oily	→ MOULD PROTECTIVE	63
	Longer-Term Protection	Visible	→ GREEN MOULD PROTECTIVE	63
			→ TOOL GUARD	64
		Clear	→ CLEAR MOULD PROTECTIVE	64
<b>Cleaning</b>	Mould & Form Solvent Cleaner		→ MOULD CLEANER	65
			→ MOULD SOLV	65
		Heavy Duty	→ POLYMER REMOVER	64
		Specialist	→ POLYESTER MOULD CLEANER	65
		Purging Compound	→ POLYKLENE R	64





## FORMULA 6

### MEDIUM DUTY SILICONE RELEASE AGENT

A general purpose release agent for all thermoplastics and many types of rubber. It is highly versatile as a release agent, ensuring accurate mould detail and improving surface finish without building up in the mould.

- Improves surface finish, minimises imperfections, and enhances even well polished tool release properties
- Operational to +200°C
- Can also be used as an anti-stick agent in the textile, foam converting, printing, and shoe industries

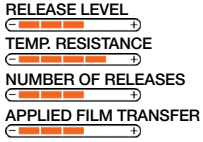

## FORMULA 1

### HEAVY DUTY SILICONE RELEASE AGENTS

Heavy duty, high silicone concentration, mould release agent available as either a 'regular' or 'high temperature' version.

- Operational temperature up to +200°C for regular version
- Automotive approved: Ford Tox No.: 168735
- Formula 1 HT is a highly effective spinneret lubricant for use in the manufacture of synthetic fibres
- "HT" Version: +200°C continuous, +300°C intermittent

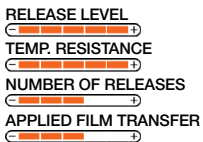

## FORMULA 2

### SILICONE RELEASE AGENT FOR RUBBER

A medium duty, silicone based release agent formulated to release natural rubber and polymers with lower melt temperatures.

- A wet silicone film for the release of moulded rubber parts
- Provides an improved surface finish and will not build up in the mould
- Operational to +200°C
- Particularly effective for use in the tyre industry
- A versatile release agent

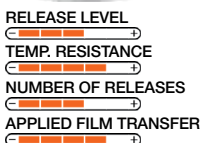

## FORMULA 8

### LIGHT DUTY, SILICONE MOULD RELEASE AGENT

Light duty, silicone mould release agent that provides a highly effective release for plastic and rubber moulding.

- Especially suitable for fine detail and precision mouldings
- Use for injection moulding, compression moulding, and vacuum forming processes
- Suitable for wax pattern release in investment casting

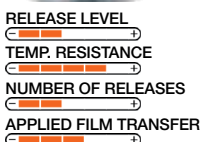





## FORMULA 20

### PAINTABLE SILICONE RELEASE AGENT

Specialist mould release agent based on a unique active material that allows post-moulding operations e.g. coating, painting, plating, and adhesion.

- No oily film - reduces the requirement to clean
- Effective on a wide variety of materials including: ABS, Polyethylene, Polypropylene, PVC, Polyamides, and Polyurethanes
- Removes the need to wax wash drying investment casting

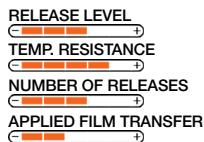

30227



## SILICONE RELEASE FG

### FOOD GRADE SILICONE RELEASE AGENT

A high purity silicone release agent for packaging and moulding operations within the food/beverage sector.

- NSF registered M1
- Suitable for use as a mould release agent (NSF M1) and packaging machine anti-stick oil (NSF H1) where the finished article will have direct to food contact
- Maximum operational temperature : +200°C
- Totally clean, clear, and non-staining 'wet' film

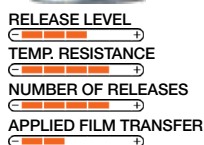

32454



## HD-SIL RELEASE

### GENERAL PURPOSE SILICONE MOULD RELEASE

A wet film, general purpose silicone release agent with excellent anti-stick and slip properties. Particularly suited to injection moulding.

- A clean, colourless, odourless release agent
- Leaves an oily, heavy duty silicone film for multiple releases
- Operational to +200°C
- Excellent materials compatibility

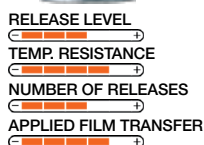

32353



## PUR 400

### SILICONE RELEASE AGENT FOR PU

A silicone release agent that has been specifically formulated to provide a fine release film for use with integral skin and elastomeric polyurethanes.

- High quality, high gloss, even finish
- Fine spray pattern for excellent coverage
- Low odour
- No build up on mould surface - suitable for use on low temperature mouldings
- Operational to +200°C

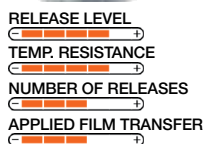

31537

31751

30317





## FORMULA 5

### MEDIUM DUTY, NON-SILICONE RELEASE AGENT

A medium duty, dry film, non-silicone mould release agent that provides an excellent release for all types of thermoplastics, some thermosetting plastics, silicone rubber, and most other rubber types.

- Will not interfere with post moulding treatments such as painting, printing, bonding, or plating
- Does not build up in the mould
- Operational to +150°C
- Automotive approval: Ford Tox No: 174011

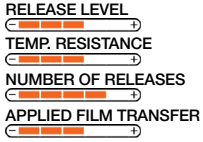

## FORMULA 4

### NON-SILICONE RELEASE AGENT FOR PVC

Excellent release for PVC, Polyurethane elastomers, and other flexible polymers. Ideal for the release of moulded shoe soles.

- A wet film mould release that imparts a gloss finish to moulded parts
- Will not interfere with post moulding operations
- Does not build up in the mould
- Operational temperature to +200°C
- Passes crib source 5, Furniture & Furnishings (Fire Safety) Regulations 1988

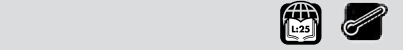
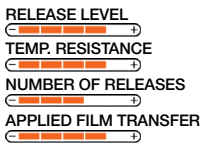

## FORMULA 7

### HEAVY DUTY, NON-SILICONE RELEASE AGENT

A wet film, non-silicone release agent that provides excellent release on a wide range of thermoplastics and rubbers.

- Will not interfere with post-moulding operations such as painting, bonding, plating, or printing
- Does not build up in the mould
- Operational temperature up to +170°C

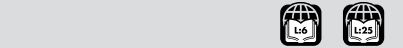
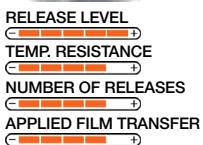

## FORMULA 10

### DRY FILM, NON-SILICONE RELEASE AGENT

Highly effective release agent for thermosetting plastics. Provides excellent release properties on polyurethanes, epoxy resins, and polyesters.

- Will not interfere with post-moulding operations such as painting, bonding, plating, or printing
- Release agent does not build up in the mould
- Operational temperature to +180°C
- Utilises fluorinated resins as the active release component

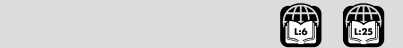
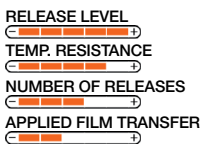



## FORMULA 11

### MINIMAL TRANSFER NON-SILICONE RELEASE AGENT

Suitable for 'electronic' grade polymer types. A non-silicone release agent with an ultra-thin, dry film, ideal for use with polymers such as Polycarbonate, ABS and HIPS (high impact styrene).

- Will not interfere with post moulding treatments such as painting, printing, bonding, or plating.
- Operational temperature to +150°C

RELEASE LEVEL  
 TEMP. RESISTANCE  
 NUMBER OF RELEASES  
 APPLIED FILM TRANSFER



31542



## NON-SILICONE RELEASE FG

FOOD GRADE NON-SILICONE RELEASE AGENT  
 A non-silicone release agent with NSF registration for use in the food/beverage industry as a packaging release.

- NSF M1 registered
- Use on food packaging which is intended for direct food contact such as plastic containers and bottles
- Will not interfere with post moulding operations such as bonding and labelling
- Operational temperature to +170°C

RELEASE LEVEL  
 TEMP. RESISTANCE  
 NUMBER OF RELEASES  
 APPLIED FILM TRANSFER



32446



## FORMULA 12

SEMI-PERMANENT NON-SILICONE RELEASE  
 Non-silicone release agent formulated to release a wide variety of synthetic rubbers and many thermoplastics such as polypropylene and polyethylene.

- Forms a thin, inert and thermally stable coating from which multiple releases can be expected
- Fast cure time. Moulding can commence 5-10 minutes after application
- Operational temperature to +250°C

RELEASE LEVEL  
 TEMP. RESISTANCE  
 NUMBER OF RELEASES  
 APPLIED FILM TRANSFER



31544



## FORMULA 14

### NON-SILICONE RELEASE AGENT

Non-silicone release agent specifically developed for the release of thermoplastics: LDPE, HDPE, PP, PVC, PS, POM, PA.

- Excellent release properties in a durable film
- Operational temperature up to +200°C
- Multiple releases per application can be achieved giving improved economy in use

RELEASE LEVEL  
 TEMP. RESISTANCE  
 NUMBER OF RELEASES  
 APPLIED FILM TRANSFER



30226





## NO-SIL RELEASE

### GENERAL PURPOSE NON-SILICONE RELEASE AGENT

Provides a wet, heavy duty film for the release of plastic and rubber parts.

- Allows decorative treatment of the moulded part (e.g. painting)
- For use in injection moulding, vacuum forming and many other forming processes
- Operational temperature to +170°C

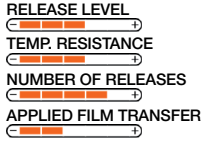

31971



## RELEASE 100

SOLVENT BASED SEMI-PERMANENT RELEASE  
 Specifically formulated to give multiple releases of a wide range of fibre reinforced polymers (including epoxy).

- Low odour and easy to apply
- Fast room temperature cure for maximum productivity
- High gloss & high slip
- Non-transferring film will not interfere with post moulding operations such as bonding, plating, coating, or labelling
- Highly versatile for use in many moulding operations

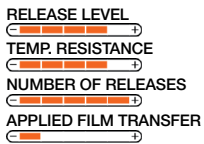

31746



## DP 200

SEMI-PERMANENT SILICONE RELEASE AGENT  
 A silicone resin based, air-curing, highly durable, dry film, semi-permanent release coating.

- Formulated for moulding processes where the use of 'free silicone' can cause stress cracking.
- Suitable for use in rotational moulding operations
- Operational temperature to +200°C
- Rolls Royce Approved: 116061

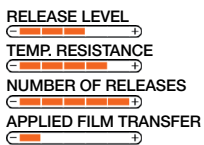

31538



## MPR 100

### READY TO USE WATER BASED SILICONE EMULSION RELEASE AGENT

Releases many types of plastic and rubber, especially PVC and rubber profile extrusions.

- Effective release of concrete/stone castings
- Operational temperature up to +150°C
- Economical in use and environmentally 'friendly'

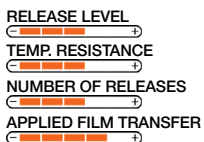

31734



## MPR 200

### READY TO USE WATER BASED SILICONE EMULSION RELEASE AGENT

Releases many types of plastic and rubber, especially PVC and rubber profile extrusions

- Especially suitable for use with PVC and rubber profile extrusions
- Ready-to-use but can be diluted for extra economy
- Double the active level of MP100
- Greater economy in use

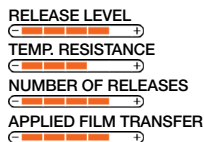

31736



## COM 300

### GENERAL PURPOSE WAX RELEASE AGENT

A general purpose liquid wax release agent effective on the following moulds: gel coated, non-gel coated, MDF, plaster, timber and aluminium.

- Simple and easy to apply liquid that can be buffed to a high gloss finish
- Multiple release of moulded components before re-coating is required

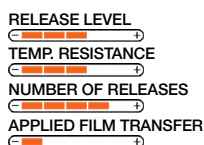

31730

31731



## COM 400

### SEMI-PERMANENT RELEASE AGENT FOR PERFORMANCE COMPOSITES

Releases epoxies, polyester, thermoplastics, thermosetting resins, boron, amide, and graphite/carbon fibre composites.

- Exhibits a fast dry time with minimal mould build up
- Practically zero applied film transfer with high thermal stability
- Ideal for use with 'difficult' moulding operations

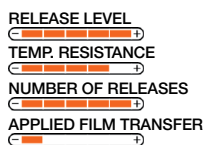

31732



## PUR 101

### RELEASE AGENT FOR SEMI-RIGID AND INTEGRAL SKIN POLYURETHANES

PUR 101 is a specialised mould release agent based upon a mixture of waxes and non-curing silicone resins in a blend of fast evaporating solvents.

- Formulated for moulding of polyurethanes, the product has proved particularly effective in automotive applications
- Minimal build up and transfer

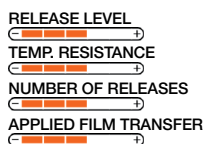

31747

31748





## PUR 300

### MOULD RELEASE AGENT FOR RIGID AND SEMI-RIGID POLYURETHANES

Specifically formulated to facilitate the release of high density rigid polyurethanes and refrigeration/insulation foams.

- Does not interfere with post moulding operations, allowing bonding, plating, painting, and labelling
- Reduced post moulding costs (no degreasing required)

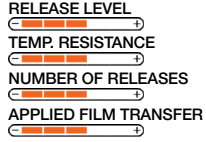

## ROM 300

### WATER-BASED, SEMI-PERMANENT ROTATIONAL MOULDING RELEASE AGENT

Specially formulated water based release agent for use in rotational moulding operations.

- Fast curing with a lower mould residue build-up
- Non-flammable
- Reduced environmental impact, safer in use

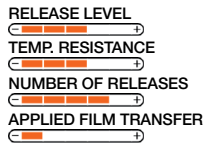

## RBR 100

### SEMI-PERMANENT RUBBER RELEASE AGENT

A water based, semi-permanent release agent for use in a wide variety of rubber moulding operations.

- Use for the release of all natural and synthetic grades of rubber
- Fast curing with lower mould build-up
- Non-flammable and environmentally 'safe'

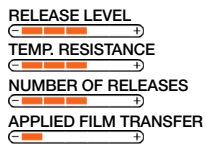

## RBR 310

### RELEASE AGENT FOR NATURAL, SYNTHETIC, AND SILICONE RUBBERS

Concentrated release agent for rubber moulding release.

- Water based with zero mould build up and minimal transfer, allowing multiple releases before re-application is required
- High 'active level' acts as a primer for new and porous mould surfaces
- Operational temperature to +250°C

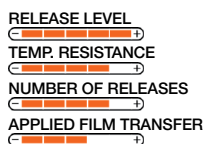



## EJECTOR PIN LUBRICANT

### MOULD TOOL LUBRICANT

A heavy duty, viscous lubricant for ejector pins and other close tolerance mould tool parts.

- Viscous film prevents creep onto mould tool face
- Lubricating film is clear and non-staining
- Operational temperature to +120°C

MATERIALS COMPATIBILITY

- LUBRICITY
- TEMP. RESISTANCE
- FILM VISCOSITY



31549



## MOULD PROTECTIVE

### CORROSION INHIBITOR FOR MOULD TOOLS

Non-silicone corrosion inhibitor for injection moulding tools and dies.

- Repels and displaces moisture leaving a durable, non-greasy protective film
- Applied film will not harden or crack
- Allows handling and resists acid finger marks
- Light yellow film ensures total coverage can be seen
- Cured film will not stain moulds

CURED FILM DRYNESS

- LONGEVITY
- PROTECTION
- FLEXIBILITY

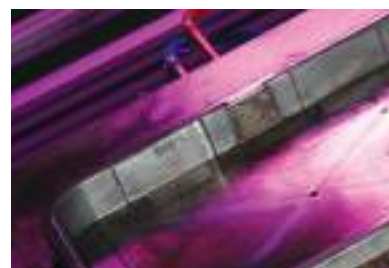

31545

31691



## GREEN MOULD PROTECTIVE

### HIGHLY VISIBLE CORROSION INHIBITOR

Tenacious and long-lasting anti-corrosion treatment for mould tools. The highly visible green spray provides easy visual inspection to ensure complete coverage.

- Non-silicone corrosion inhibitor for injection moulding tools
- Repels and displaces moisture leaving behind a durable protective film for excellent long-term tool storage
- Waxy film allows handling & will resist acid finger marks
- Easily moulded off once production recommences
- Ideal for the long-term storage of mould tools

CURED FILM DRYNESS

- LONGEVITY
- PROTECTION
- FLEXIBILITY



31546



## BLUE MOULD PROTECTIVE FG

### HIGHLY VISIBLE CORROSION INHIBITOR FOR FOOD PACKAGING

A waxy, long lasting coating for mould tools and dies which is NSF registered for use in the food/beverage sector.

- Non-silicone corrosion inhibitor for injection moulding tools
- NSF H2 registered (No.149685)
- Ideal for long-term storage of mould tools, dies, and jigs
- Highly visible blue dye provides an easy visual method for ensuring complete coverage
- Easily moulded off once production recommences

CURED FILM DRYNESS

- LONGEVITY
- PROTECTION
- FLEXIBILITY



32449





## TOOL GUARD

### LIGHT GREEN MOULD TOOL PROTECTIVE

A light green, viscous, protective coating for use on mould tools. It removes moisture and provides good, long-term protection to surfaces.

- Easy identification of treated areas for total coverage
- Will not penetrate or creep into the mould tool
- Resists high humidity and acid finger marking
- Easy to apply with good wetting properties
- Excellent corrosion protection
- Also available in a clear version as Tool Guard Clear

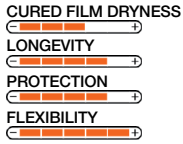

31972 (GREEN)  
32708 (CLEAR)



## CLEAR MOULD PROTECTIVE

### TRANSPARENT CORROSION INHIBITOR

Use on moulds as a long-term protective during storage. Carries NSF registration for use on food/beverage packing mould tools.

- Displaces moisture leaving a durable, non-greasy protective film
- NSF H2 registered (No.49688)
- Will not stain or mark the mould; suitable for use with white and transparent polymers
- Easily "moulded off" when production recommences
- Waxy film allows handling and resists acid finger marks

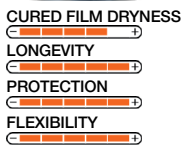

31547



## POLYMER REMOVER

### HEAVY DUTY MOULD CLEANER

Highly effective and powerful solvent blend developed for use on polymer residues and soiled tooling/equipment.

- Controlled rate of evaporation for maximum efficiency
- Removes: plastics, rubbers, and resin deposits including: ABS, Acetals, Acrylates, PVC, Epoxy Resins (uncured), Polyamides, Polystyrenes, Silicone Resins, and Rubbers
- It will also remove other materials such as cellulose resins and alkyd resins

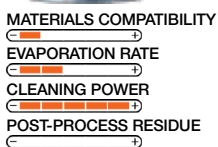

31551 31688



## POLYKLENE R

### INJECTION MOULDING AND EXTRUSION EQUIPMENT CLEANING COMPOUND

A screw and barrel cleaning compound that changes state when heated in the barrel, reaching into the dead spaces where burnt material will settle.

- Removes residues of previous production runs e.g. black specs caused by burnt on resin
- Reduce scrap rates by removing tainting residues, such as pigments during colour changes

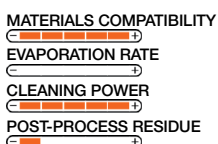

2.5kg 31683 25kg 31684







## MOULD CLEANER

### GENERAL PURPOSE CLEANER FOR MOULD TOOLS

A powerful solvent blend formulated to remove a wide range of common soiling from moulds, tools & dies.

- Quickly and easily removes oils, grease, old protective films & release agents
- Ideal for removing old release agents
- Evaporates to leave a clean, dry, residue free surface
- Special formulation allows use on hot production tooling without excessive solvent loss

MATERIALS COMPATIBILITY  
 EVAPORATION RATE  
 CLEANING POWER  
 POST-PROCESS RESIDUE



## SOLVENT CLEANER FG

### FOOD GRADE SOLVENT CLEANER FOR MOULD TOOLS

A general purpose solvent cleaner that is suitable for use in the food/beverage sector.

- Quickly removes oils, greases, waxy protective films, and release agent residue
- Evaporates to leave a clean, dry, residue free surface
- Excellent materials compatibility
- Low odour

MATERIALS COMPATIBILITY  
 EVAPORATION RATE  
 CLEANING POWER  
 POST-PROCESS RESIDUE



## POLYESTER MOULD CLEANER

### SOLVENT CLEANER FOR MOULDS

A blend of powerful solvents specifically developed to remove semi-permanent mould release coatings used in GRP and rotational moulding from a wide variety of mould substrates.

- Safe for use on GRP and gel coated moulds
- Effective removal of semi-permanent, silicone, and wax release agents
- Compatible with all Ambersil composite release agents

MATERIALS COMPATIBILITY  
 EVAPORATION RATE  
 CLEANING POWER  
 POST-PROCESS RESIDUE

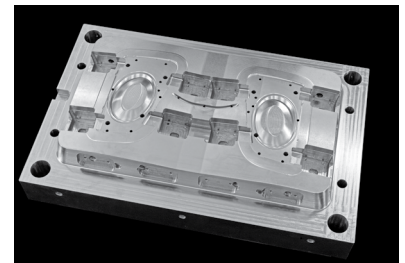

## MOULD SOLV

### SOLVENT CLEANER FOR MOULDS & TOOLS

A medium power, low odour solvent for the general cleaning and preparation of mould tools.

- Highly effective low odour degreasing agent
- Safe for use on plastics, metals, painted and glazed surfaces
- Removes anti-corrosion coatings and old release agents

MATERIALS COMPATIBILITY  
 EVAPORATION RATE  
 CLEANING POWER  
 POST-PROCESS RESIDUE



**ADD**

The Aerosol Dispensers Directive is a piece of European legislation, the primary purpose of which is to protect consumer and end-user safety in relation to the use of aerosol dispensers. Amongst other criteria, ADD requires that all filled aerosols are tested to ensure complete integrity (water bath testing to 50°C) and that all formulations are thoroughly tested to evaluate potential flammability – and labelled accordingly. With the addition of the compliance mark (the reversed epsilon 'ε') located on the aerosol can itself, consumers are able to confirm that the aerosol has been tested to rigorous EU standards.

**AEROSOL**

A self-contained sprayable product comprising of a mixture of active ingredients, carriers and propellant contained in a steel or aluminium container which discharges the formulation under pressure. Aerosols are hermetically sealed, ensuring risk of spillage is removed, storage simplified, and combustion risks minimised - all benefiting Health & Safety guidelines. Assists with precise and controlled application.

**BARRIER PROTECTION**

Barrier protection is one of two primary methods of protecting metals from corrosion. By coating the metal with a suitable product (e.g. Acrylic Paints; Bright, Cold Galvanise; Inox 200, etc), corrosion is unable to take place because electrolytes (such as rain water) are unable to come into contact with the metal and an electron flow cannot be established, thus preventing galvanic corrosion.

**BIODEGRADATION / BIODEGRADABLE**

The process by which organic substances are broken down into harmless constituents by the natural action of living micro-organisms.

**CATHODIC PROTECTION**

Cathodic protection is based on the ionic charge of the metal and the reversal or mitigation of the flow of electrons as found in galvanic corrosion. The protective coating applied should have a lower potential (volts) than the metal it is to protect so that the coating is corroded in preference to the base metal – with protection often extending beyond the physical edge of the coating. By offering itself for corrosion instead of the base metal, this type of coating is often termed 'sacrificial' and is, in essence, how galvanised steel is protected.

**CHLORINATED SOLVENTS**

Chlorinated solvents are organic solvents which contain chlorine atoms as part of their chemical make-up. These compounds are very effective solvents for oils and greases.

**DIELECTRIC STRENGTH**

The maximum electrical field strength that an insulating material can withstand intrinsically without decomposing, usually specified in volts per millimetre of thickness. Also known as the breakdown voltage.

**EDTA**

EDTA is the chemical compound ethylenediaminetetraacetic acid, also known as diaminoethanetetraacetic acid disodium salt. It is most commonly used as a constituent in water based cleaning chemicals to bind with a water soluble compound. This use has now become less prominent due to concerns over the biodegradability and EDTA has also found some specialist uses as a preservative in some processed foods and cosmetics.

**EMULSION**

A combination of water-soluble and water insoluble chemical groups held together by a surfactant. Emulsions are usually milky white.

**EVAPORATION RATE**

The rate at which a material will vaporise (evaporate) when compared to the known rate of vapourisation of a standard material. The designated standard material is usually n-butyl acetate, with a vaporisation rate designated as 1.0. The higher the number, the faster the evaporation rate.

**FDA**

The FDA (Food and Drugs Administration) ensures that all ingredients used in foods are safe, and that food is free of contaminants such as disease-causing organisms, chemicals, or other harmful substances. The FDA reviews the results of laboratory, animal and human clinical testing conducted by companies to determine if the product they wish to place on the market is safe and effective. The FDA does not develop or test products itself, nor issue approvals'.

**FLASH POINT**

The lowest temperature at which the vapours of a solvent will flash (ignite) under specific test conditions.

**GALLING**

The process by which metal components 'cold weld' and seize. When two metals are brought together under pressure, the action of forcing the surfaces together can cause the contacting faces to begin to combine at an atomic level, fusing the pieces together. Where stainless steel or aluminium alloys are used, the friction can scour off the thin, non-reactive protective oxide layer, exposing clean reactive material - allowing atomic fusing to occur. Galling can be prevented by the use of a lubricant, such as bearing grease, however, grease needs to be 'worked' before full lubrication is achieved, therefore a running-in paste should be used to prevent galling in this start-up period.

**GALVANIC CORROSION**

Is an electrochemical process which occurs when two metals with differing electrical potentials are in contact with each other in the presence of an electrolytic solution (such as rain water).

**GALVANISING**

Galvanising is the process by which clean, degreased ferrous metal (i.e. steel) has a layer of zinc applied to its surface using extreme heat to form an inseparable alloy at the point where the two layers are fused. Zinc will be corroded in preference to the ferrous substrate thereby preventing structural corrosion. This type of coating is referred to as a 'sacrificial coating'.

**GHS/CLP:**

The Classification, Labelling and Packaging (CLP) Regulation implements the UN Global Harmonised System (GHS) in all EU member states. Currently there are several differing pieces of legislation relating to the classification, labelling and packaging of dangerous substances worldwide. GHS will implement identical criteria for classifying chemicals according to the health, environmental and physical hazards; and also for how hazards are communicated via product labels and MSDS's. Manufacturers will need to plan the phase-in of complete label and packaging (print) re-design; the updating of all MSDS's and the communication of these changes through the channel. These changes will include the introduction of new hazard warning pictograms and harmonised warning and precautionary statements on labels, which will replace the existing risk and safety phrases.

**GWP:**

Abbreviation for "Global Warming Potential". GWP is an industry recognised, arbitrary measure of the effect of various chemicals on global warming. The benchmark reference is Carbon Dioxide (CO<sub>2</sub>) with a score of 1 for 1kg. A product that contributes twice as much to global warming would have a score of 2 for 1kg, indicating double the impact for the same amount. As the number gets higher, so the effect of 1Kg of the material can be seen to be proportionally more severe than CO<sub>2</sub>. The score allows users and specifiers to consider the environmental impact of the products they are using. Not all products on the market will have a GWP score.

**HAZARD SYMBOLS:****EXTREMELY FLAMMABLE (F+)**

Liquid chemicals having an extremely low flash point and low boiling point and gaseous chemicals which are flammable in contact with air at ambient temperature and pressure in the presence of an ignition source.

**HIGHLY FLAMMABLE (F)**

Liquid chemicals that have a very low flash point.

**HARMFUL (Xn)**

Chemicals that may cause damage to health when inhaled swallowed or absorbed via the skin.



## IRRITANT (Xi)

Chemicals that may cause inflammation to the skin or other mucous membranes through immediate, prolonged or repeated contact.



## DANGEROUS FOR THE ENVIRONMENT (N)

Chemicals that may present an immediate or delayed danger to one or more components of the environment.



## ISO 9001

Internationally recognised Quality Management system standard, indicating Ambersil's commitment to quality and continuous improvement. The standard has been developed to provide a framework around which a quality management system can effectively be implemented.

## ISO 14001

Internationally recognised environmental management standard. Specifies the requirements for an environmental management system; provides a framework for an organisation to control the environmental impacts of its activities, products and services, and to continually improve its environmental performance.

## KB VALUE

The Kauri Butanol (KB) value is a measure of the relative solvent power of a hydrocarbon liquid. The higher the KB value, the more powerful the solvent.

## MODULUS

Where two substrates/surfaces are bonded together with either an adhesive or sealant, they are often subject to forces which could, with enough pressure, result in the bond failing. Modulus is measured in Pascal's. Low modulus means the bond is more flexible and has more 'give' in it, i.e. good for expansion joints. High modulus means that the bond is stiffer and less flexible.

## MRO

Abbreviation for the term "Maintenance, Repair, and Overhaul". Typically associated with the service and repair sectors, including plant and site maintenance / engineering.

## NLGI GRADE

A widely used classification for lubricating greases established by the National Lubricating Grease Institute and a reference to the measure of the consistency of a particular grease. The most common consistency number is #2. Softer grades, especially #0 and #1, are often used for improved low-temperature service. High consistency numbers, #3 through #6 are used for certain high-speed bearings where leakage and sealing are particular concerns. The higher the number, the more viscous the grease.

## NSF EXPLAINED

NSF is an abbreviation for the National Sanitation Foundation, which was founded in 1944 as a not-for-profit, non-governmental organisation. NSF International is a global provider of public health and safety risk management solutions to companies, governments and consumers. In 1999, it launched its voluntary Non-food Compounds Registration Program to re-introduce the previous authorisation program administered by the U.S Department of Agriculture (USDA). Product evaluation is based on formulation and label review and products which comply with the relevant regulations and guidelines receive a Letter of Authorisation and are included in the 'NSF White Book'™.

## NSF CATEGORIES

### A1

Acceptable for use as a general cleaner on all surfaces in and around food processing areas, where its use is not intended for direct food contact. All food products and packaging materials must be removed or protected prior to product use. After use of this product, surfaces should be rinsed with potable water. The cleaner should not exhibit a noticeable odour nor leave a visible residue.

### A7

Acceptable as a metal cleaner and polisher for non-food contact surfaces (A7) in and around food processing areas. All food products and packaging materials shall be removed or carefully protected prior to usage. This compound must be used in a manner so that all odours associated with the compound are dissipated before food products or packaging materials are re-exposed in the area.

### A8

Acceptable for use as a degreaser or carbon remover for food cooking or smoking equipment, utensils, or other associated surfaces in and around food processing areas, where its use is not intended for direct food contact. All food products and packaging materials be removed or protected prior to product use. A potable water rinse of cleaned surfaces is required after use of this product.

### C1

Acceptable for use in inedible product processing areas, non-processing areas, and/or exterior areas of food processing establishments provided that it is not used to mask odours resulting from unsanitary conditions, and that any characteristic odour or fragrance does not penetrate into an edible product area. When used on equipment that will be returned to a food processing area, the product must be completely washed off and rinsed with potable water before returning to the processing area.

### D2

Acceptable for use as a sanitiser on all surfaces not always requiring a rinse in and around food processing areas. Before using this compound, food products and packing material must be removed from the room or carefully protected. A potable water rinse is not required following the use of this compound on previously residue remains which can adulterate or have a deleterious effect on edible products.

## 3H

This product is acceptable for use as a Release Agent on grills, ovens, loaf pans, boning benches, chopping boards, or other hard surfaces in contact with meat and poultry food products to prevent food from adhering during processing.

## M1

This product is acceptable for use as a mould release agent on moulds that are used to produce packaging material that will contact food to prevent the finished product from adhering to the mould. The amount used on the equipment should be the minimum required to accomplish the effect.

## H1

This product is acceptable as a lubricant with incidental food contact for use in and around food processing areas. Such compounds may be used on food processing equipment as a protective anti-rust film, as a release agent on gaskets or seals of tank closures, and as a lubricant for machine parts and equipment in locations in which there is a potential exposure of the lubricated part to food. If used as an antirust film, the compound must be removed from the equipment surface, leaving the surface effectively free of any substance which could be transferred to food.

## H2

Acceptable as a lubricant where there is no possibility of food contact (H2) in and around food processing areas. Such compounds may be used as lubricants, release agents, or antirust films on equipment and machine parts in locations in which there is no possibility of the lubricant or lubricated part contacting edible products.

## K1

This product is acceptable for use as a cleaner and degreaser for use in non food processing areas, which are used to remove oil, wax, resinous materials, or other substances not removable by using acidic or alkaline cleaning agents. Their use is limited to non-processing areas where there is no possibility of solvent vapours entering a processing area. Food processing equipment or utensils treated with such preparations must be washed with an acceptable detergent solution and thoroughly rinsed with potable water before returning to a processing area.

## K2

This product is acceptable for use as a solvent for cleaning electronic instruments and devices, which will not tolerate aqueous cleaning solutions in and around food processing areas, where its use is not intended for direct food contact. Before using this compound, food products and packaging materials must be removed from the area or carefully protected. This compound must be used in a manner so that all odours associated with the compound are dissipated before food products or packaging materials are re-exposed in the area.

**K3**

This product is acceptable for use as an adhesive or glue remover, for removing adhesive or glue from food packaging materials in and around food processing areas, where its use is not intended for direct food contact. Before using this compound, food products and packaging materials must be removed from the area or carefully protected. After using these compounds, all surfaces must be thoroughly washed with an acceptable detergent solution, and rinsed with potable water. This compound must be used in a manner so that all odours associated with the compound are dissipated before food products or packaging materials are re-exposed in the area.

**P1**

For Universal Screen Cleaner: This product is acceptable for use as a TFT, LCD and plasma screen cleaner, in and around food processing areas. The products must only be used in such a manner as to ensure it will have neither direct nor indirect contact with food or potable water.

**OZONE DEPLETERS**

Halogen-containing substances known to reduce the protective effects of the stratospheric ozone layer. Aerosols manufactured within Europe have been free of ozone depleting substances for many years.

**pH**

A scale ranging from 0 to 14 used to measure acidity and alkalinity. The lower the number the more acidic; the higher the number, the more alkaline; 7 is neutral.

**POTABLE WATER**

Water of sufficient quality to serve as drinking water is called potable water whether it is used as such or not. Although most fresh water sources are drinkable by humans, they can be a disease vector or cause long-term health problems if they do not meet certain water quality guidelines.

**PTFE**

The abbreviation for polytetrafluoroethylene, PTFE, appears in the Guinness Book of Records as having the lowest coefficient of static and dynamic friction of any solid. This value, at 0.02, is equivalent to wet ice on wet ice, indicating its extreme anti-friction properties.

**REACH**

Registration, Evaluation and Authorisation of Chemicals. REACH is an EU-wide reform of the regulatory environment in which chemicals are used and will eventually replace and update many other pieces of chemical control legislation. The aim is to reduce the risks to human health and the environment through the methodical and accurate identification of the properties of chemical substances. Whilst there is no definitive list of 'approved' chemicals as yet, a series of deadlines will ensure that the highest volume and most harmful are evaluated first. REACH relies on end-user application information to be filtered up through the supply chain to establish accurate registration and evaluation. More information can be found at: [www.hse.gov.uk/reach](http://www.hse.gov.uk/reach).

**RAL**

In 1925, the private sector and the German government founded the "Reichsausschuss für Lieferbedingungen" - RAL - (Committee of the German Reich for Terms and Conditions of Sale). RAL's original task was to standardise precise technical terms of delivery and sale. The RAL colour collection comprises over 200 colours with a four-digit numbering. The registers also include safety and signal colours and they comply with the requirements of the DIN standards (German Industrial Standards). The basic collection for matt colour shades is the register RAL 840 HR while it is the RAL 841 GL register for gloss colours. RAL 840 HR is the European-wide 'registered' standard colours for the coatings industry.

**RTV (ROOM TEMPERATURE VULCANISATION)**

Vulcanisation refers to a specific curing process of rubber involving high heat and the addition of sulphur. It is a chemical process in which polymer molecules are linked to other polymer molecules resulting in springy rubber molecules which become cross-linked. This makes the material harder, much more durable and also more resistant to chemical attack. Vulcanisation which occurs without the need for heat and sulphur, usually by the addition of activating chemicals, is known as Room Temperature Vulcanisation as the rubber 'cures' at around 25°C.

**SHELL 4-BALL WELD**

An industry standard test which provides an indication of the load bearing capability of a lubricant. A steel ball is loaded and rotated against 3 fixed steel balls for 10 seconds. At the end of each 10 second run, a further weight is loaded onto the balls, and the test re-run using fresh lubricant. The test is complete when the balls weld together. The weld point is the load at which this occurs. The higher the weld point, the greater the lubricity (lubricating ability) of the grease.

**SURFACTANT**

A descriptive term derived from 'Surface Active Agent', a specialised compound that is typically used to connect water soluble and water insoluble chemical groups. Can be used to improve the emulsifying, foaming, dispersing and wetting properties of a product

**THIXOTROPIC**

A term used to describe fluids which are shear thinning. In essence, most thixotropic substances are gel-like, meaning that they retain their shape upon application, but when heated or subjected to shear stress, their shape will change and they will become thinner. The word comes from the Greek 'thixis' for touch and 'tropy', from 'tropos' meaning changeable.

**USDA**

The USDA (United States Department of Agriculture) used to authorise the use of non-food compounds, including cleaning agents and lubricants, within the Food Industry sector. In 1999, this former authorisation program was reintroduced as a voluntary registration program by NSF International. USDA categories for lubricants: USDA H1 for incidental food contact (above the food line) USDA H2 for where there is no possibility of food contact (below the food line).

**VISCOSITY**

A term used to describe the resistance to flow or degree of 'thickness' of a liquid, usually expressed in units of poise or stokes. The more viscous a product, the thicker its consistency.

**WELLS DISEASE**

Weil's disease is a particularly dangerous disease which is predominantly caught from standing water infected with the pathogen (bacteria) known as *Leptospira*, from rat and rodent urine. Symptoms are similar to those of influenza, meningitis, hepatitis, dengue or viral haemorrhagic fevers and can be fatal if left untreated.

**WRAS**

The Water Regulations Advisory Scheme is the UK Water Industry's approval scheme. Products approved by the scheme have been shown to comply with the requirements of the Water Supply (Water Fittings) Regulations 1999 and amendments. The scheme is designed to promote knowledge of the regulations with a view to preventing the waste, undue consumption, misuse or contamination of drinking water. Approved products can be found at [www.wras.co.uk/directory](http://www.wras.co.uk/directory).

# GREENLIGHT™ – CHEMICAL CONTROL THROUGH COLOUR CODING

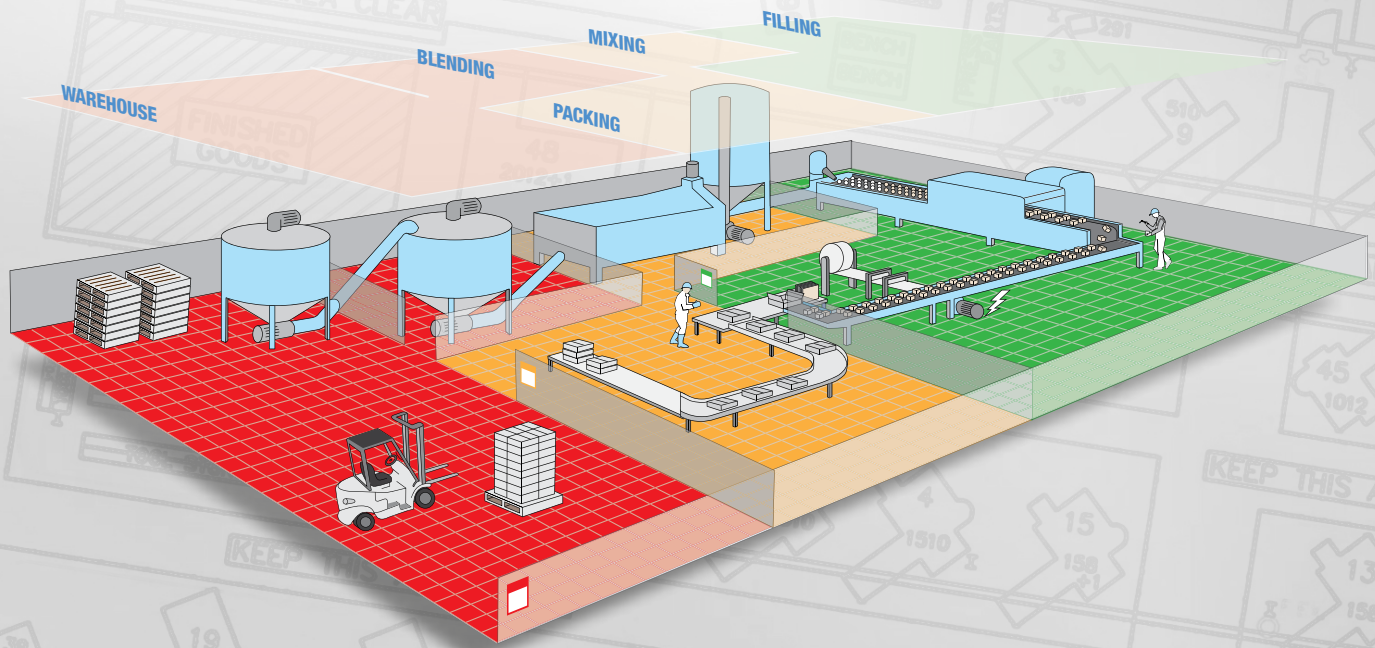

## GREENLIGHT™ Chemical Control Through Colour Coding

### Audit compliant

Elements of the common supermarket and BRC audits already call for maintenance chemical control; GREENLIGHT™ takes these criteria and offers a verifiable solution for the audit check-list.

### Accessible

GREENLIGHT™ is accessible to all users, regardless of native language. Colour coding is widely understood and is highly visible. For users who have limited colour vision, all signs contain the product name (which is not language-dependent) as well as displaying the zone colour in multi-language texts.

### Product choice

GREENLIGHT™ has been developed to be used alongside the comprehensive Ambersil range of products. However, GREENLIGHT™ will work with any chemical brands should an equivalent Ambersil product not be available.

### Totally flexible

GREENLIGHT™ can be implemented in any facility that requires maintenance chemical control. Not just the food/beverage/pharma industries.

### Easy to understand and set-up

GREENLIGHT™ is based on well understood concepts such as HACCP, zoning and colour coding.



## CONTENTS BY NAME

3H OIL FG	39	Freezer /2	27	White Spirit	17
40+	30	Galva Colour	50	White Spray Grease	38
5005A Silicone Adhesive Sealant	53	Galvanising Zinc Rich	48	Wire Rope Lubricant	35
5024A Silicone Adhesive Sealant	53	Galva Shine	48	Zinc Primer	50
Acrylic Conformal Coating	27	Gasket Stripper GS5	22		
Acrylic Paint	47	Gear Oil Super 150/220/320 FG	40		
Adhesive HS 300	52	Gear & Wire Rope Lubricant	34		
Adhesive MP 100	52	Glass Cleaner	22		
Adhesive NC 500	52	Graphite Lock Lube	36		
Adhesive QS 900	52	Graphite Release Spray	36		
AGL 1	30	Green Mould Protective	63		
Air Duster /2	23	Hand Cleaner Plus	17		
Alu Hi-Temp	49	Hand Cleaning Wipes	18		
Amberclens	14	Hard Surface Cleaner	16		
Amberclens FG	14	Hard Surface Sanitising Wipes FG	18		
Amberglide	33	HD-Sil Release	57		
Ambergrease EXL	36	High Temperature Gasket Sealant	53		
Ambergrease FG1	37	High Temperature Lubricating Oil FG	35		
Ambergrease FG2	37	Hi-Load Lube FG	38		
Ambergrease FG3	37	Hydraulic Oil Super 32/46/68 FG	40		
Ambergrease FG4	37	Industrial Degreaser FG	20		
Ambergrease SIL	38	Inox 200	49		
Amberklene FE10	19	Invertible Air Duster /2	23		
Amberklene FG	20	IPA Solvent	26		
Amberklene LO30	19	Label & Adhesive Remover FG	24		
Amberklene ME20	19	Label Remover	24		
Ambersolv AB1/Foaming Cleaner	14	Leak Detector	44		
Ambersolv SB1	21	Lec-Klene	21		
Ambertron	25	Lubricating Oil 'LO' 32/68/100	41		
AMS4 Silicone Grease	39	Machine Oil FG	31		
Anti-Static Spray	24	Marker Pens	51		
Aqua Marker Pens	51	Moisture Remover FG	30		
Assembly Paste FG	34	Mould Cleaner	65		
BA40 Solvent	21	Mould Protective	63		
Battery Terminal Protector	49	Mould Solv	65		
Belt Dressing FG	35	MPR 100	60		
Bioweld	44	MPR 200	61		
Blue Adhesive Lubricant	36	Multi-Lube	31		
Blue Mould Protective FG	63	Multi Oil 32/46 FG	41		
Brake Cleaner	19	Multi-Surface Polish	22		
Bright, Cold Galvanise	48	NF Precision Cleaner	25		
CCL 100	26	Non-Silicone Release FG	59		
Chain Lube FG	35	No-Sil Release	60		
Chainspray	34	Paint & Graffiti Remover	22		
Citrus Cleaner & Degreaser	15	PCB Cleaner	26		
Clear Mould Protective	64	Penetrating Oil	31		
Cold Galvanise	48	Penetrating Oil FG	31		
COM 300	61	Polyester Mould Cleaner	65		
COM 400	61	Polyklene R	64		
Contact Cleaner FG	25	Polymer Remover	64		
Copper Anti-Seize Paste	34	PUR 101	61		
Corrosion Inhibitor	49	PUR 300	62		
Degreaser FG	15	PUR 400	57		
Degreaser RTU & Degreaser Low Foam	14	PX24	30		
DP17	16	RBR 100	62		
DP 200	60	RBR 310	62		
Dry Film Anti-Stick	33	Release 100	60		
Dry Moly	33	ROM 300	62		
Dry PTFE Lube FG	33	Rust Converter	50		
Duster One	23	Rust Flash	32		
Dust Remover	23	SBP 11	17		
Easy Weld	44	Silicone Anti-Stick	32		
Ejector Pin Lubricant	63	Silicone FG	32		
Engineers Wipes	18	Silicone Lubricant	32		
Fast Clean 200/201	21	Silicone Oil	39		
Flaw Detectors:Cleaner/Penetrant/Developer	45	Silicone Release FG	57		
Flux Remover	26	Solvent Cleaner FG	20		
Food Grease FG	38	Solvent Cleaner FG	65		
Formula 1	56	Solvent Degreaser	20		
Formula 2	56	Spatter Release	44		
Formula 4	58	Stainless Steel Cleaner FG	15		
Formula 5	58	Sugar Remover & Inhibitor FG	15		
Formula 6	56	SV100	27		
Formula 7	58	Terrazzo Cleaner	16		
Formula 8	56	Tool Guard	64		
Formula 10	58	Tough Wipes	18		
Formula 11	59	Traffic Film Remover	16		
Formula 12	59	Tufcut:Liquid/Spray/Foam/Compound/Aqua	43		
Formula 14	59	Ultrasonic Cleaning Fluid	27		
Formula 20		Universal Screen Cleaner	24		

# Ambersil

Ambersil House  
Wylde Road  
Bridgwater  
Somerset  
TA6 4DD  
United Kingdom

[www.ambersil.com](http://www.ambersil.com)

**t** +44 (0)1278 727200

**e** [sales.uk@ambersil.com](mailto:sales.uk@ambersil.com)

© CRC Industries UK Ltd. 2017  
Registered in England and Wales.  
Company No. 04910479



In Partnership with

